

DB4318H-2C

164-168.5 MHz Single Channel Filter and Isolator

Tuning Instructions

TUNING INSTRUCTIONS

Important: Initial tuning should be performed at reduced power (10-20 watts).

1. With Tx power off, set up configuration as shown in Figure 1.
2. Set Tx to normal operating power.
3. Adjust capacitor 1 until wattmeter W1 shows minimum reflected power.

4. Alternately adjust capacitors 2 and 3 until wattmeter 2 shows minimum power.
5. Adjust capacitor 4 until wattmeter W3 shows minimum power.
6. Allow Tx to run 5-10 minutes.
7. Repeat steps 3-5.
8. Turn off Tx. Restore to normal configuration without the wattmeters.

Note: The above steps should be performed as part of the normal combiner maintenance procedure.

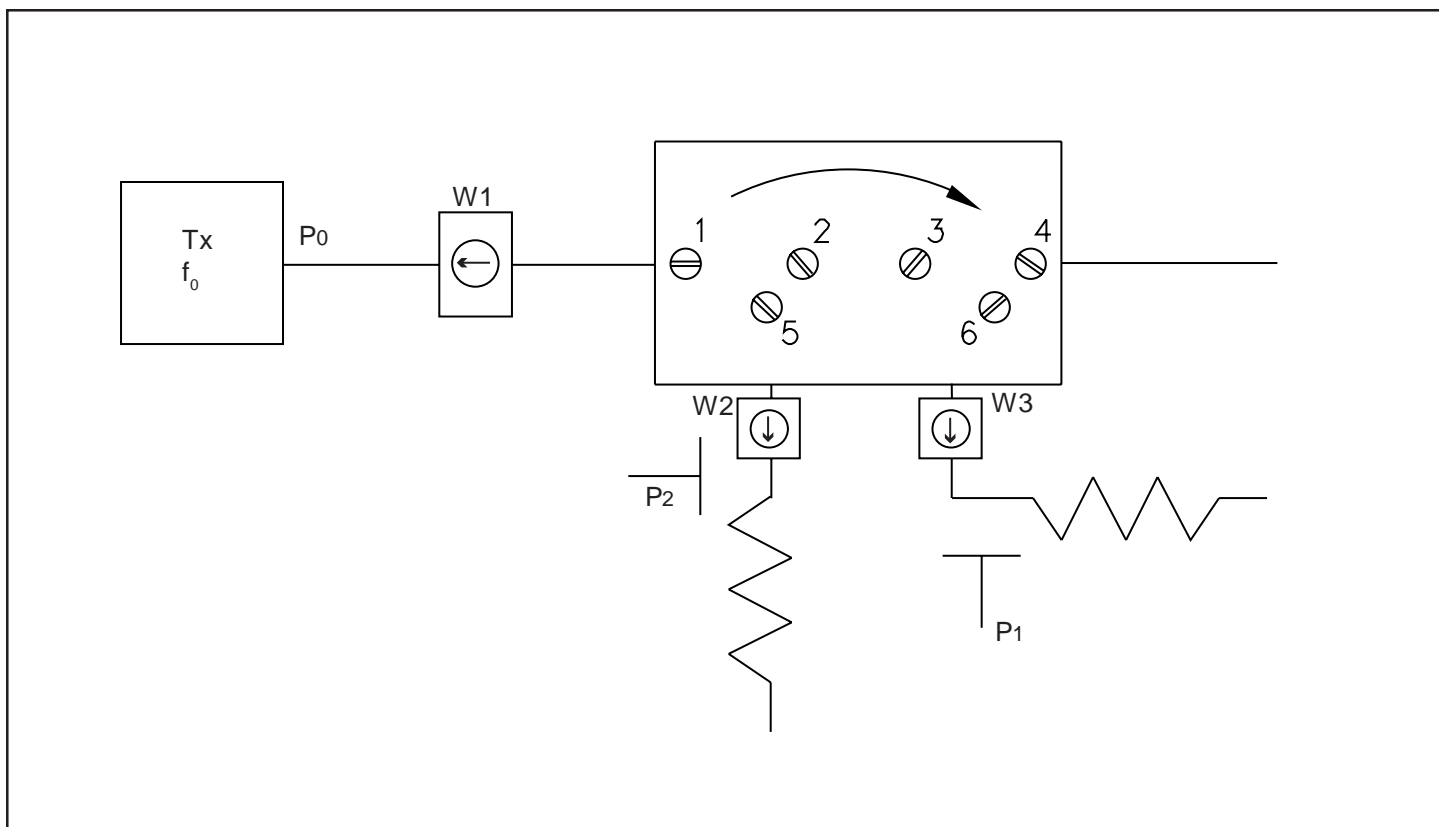

Figure 1 - Equipment Setup

