

Band Pass Cavity Filters

Installation and Tuning Instructions

Applicable to the following models:

DB4001 (148-174 MHz)	DB4026 (406-512 MHz)	DB4013 (88-118 MHz)	DB4028 (806-960 MHz)
DB4011 (70-88 MHz)	DB4042 (30-50 MHz)	DB4018 (225-400 MHz)	DB4170 (138-174 MHz)
DB4015 (118-148 MHz)	DB4002 (118-512 MHz)	DB4021 (406-512 MHz)	DB4171 (450-512 MHz)
DB4020 (406-420 MHz)			

GENERAL

Decibel Products Bandpass Cavity Filters are generally used to provide additional selectivity to a receiving system or to reduce the sideband noise output of a transmitter. The filters, available in one, two, three, or more cavity combinations, have a unique feature enabling a change in selectivity simply by rotating the coupling loops. The insertion loss values for these loop settings are approximately 0.5 dB, 1.0 dB, and 2.0 dB. An insertion loss of 1.0 or 2.0 dB will increase the filter selectivity with minimal attenuation of the desired signal.

CAVITY INSTALLATION

Smaller cavity filters are easily rack mounted with rail or panel configurations. Refer to catalog specifications for specific mounting details for each model.

RECEIVER SELECTIVITY IMPROVEMENT

1. Insert the filter between the receiver input and the antenna -- or between a signal generator and the receiver if bench tuning. (A 50 ohm pad should be used between the signal generator and the cavity to insure a proper impedance match.)
2. Tune the cavity until a peak reading is obtained on the second limiter. (Care should be taken to insure that the grid current of the second limiter is well below limiting.) Clockwise rotation of the tuning knob lowers the resonant frequency of the cavity.
3. If a multiple cavity filter is being used, tune each cavity for maximum limiter reading. Because of the interaction between the cavities, it will be necessary to retune each cavity three or four times to insure proper final adjustments.
4. When the tuning is completed, tighten the locknut on the tuning shaft of each cavity.

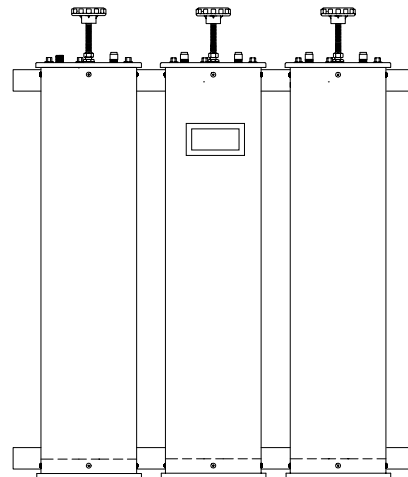

Figure 1 -
Typical Rail
Mounting:
5" Cavity

TRANSMITTER NOISE AND SPURIOUS RADIATION REDUCTION

Method 1 -- Minimum reflected power:

1. Install the filter between the transmitter and a matched dummy load. (Note: This tuning method should not be used with the antenna connected to the system. A condition could exist where a reactive mismatch due to the antenna would be canceled by the off-resonance reactance of the cavity filter. This would leave the filter, although apparently tuned, off resonance presenting a higher insertion loss to the transmitted signal. Multiple cavity filters are more critical in this respect.)
2. Insert an inline watt meter between the transmitter and the cavity capable of indicating reflected power from the cavity.
3. Set the transmitter to "tune".
4. Key the transmitter and tune the cavity for minimum reflected power. This is an indication of proper cavity resonance.

(Continued on page 2)



DECIBEL PRODUCTS
A Division of Allen Telecom Inc.

8635 Stemmons Freeway • P. O. Box 569610 • Dallas, Texas 75356-9610
214 / 631-0310 • Fax: 214 / 631-4706



(Continued from page 1)

- Multiple cavity filters may be tuned by the above method remembering that because of interaction between cavities, each cavity may have to be retuned three or four times to insure proper final adjustment.
- Remove the watt meter from the line and connect the transmitter and filter to the antenna. No further tuning should be necessary.

Method 2 -- Maximum power:

- Install the filter between the transmitter and the antenna.
- Insert a watt meter between the antenna and the filter.
- Set the transmitter to "tune" and the watt meter to read "forward".
- Key the transmitter and adjust the cavity(s) for maximum power to the antenna. (For multiple cavity filters, retune each cavity three or four times for proper final adjustment.)
- Set the transmitter to "operate" and again retune the cavity(s) for maximum power to the antenna.
- Tighten locknuts on cavities and remove watt meter.

Optimizing the cable length

With some transmitters it may be necessary, because of impedance mismatches, to optimize the length of cable between the transmitter and the first cavity in the filter.

The need for this optimization will be apparent when the output power from the transmitter is reduced by more than the amount absorbed in the cavity(s) due to insertion loss.

The optimum length of cable between the transmitter and the cavity can be empirically found by the following method:

- Tune the transmitter to its antenna according to the instruction book.
- Insert the cavity(s), which have been tuned by either of the previous methods between the transmitter and the antenna. If there is a mismatch problem, the cavity will detune the transmitter.
- Using either short lengths of cable or UG27 elbows, increase cable lengths between the transmitter and cavity(s) until there is little or no interaction or detuning between the transmitter and the cavity(s).
- Replace the cable containing the UG27 elbows and/

or short lengths with a continuous length of cable of equivalent electrical length (one elbow is approximately 1-1/2" of RG214). The system should now be optimized.

ADJUSTING SELECTIVITY

Each bandpass cavity filter is provided with adjustable selectivity capability. This is accomplished by physically rotating the coupling loops within the cavity to positions corresponding to total cavity attenuations of 1/2 dB or 2 dB. Setting the loops to a higher insertion loss increases the selectivity or sharpens the frequency response curve of the cavity. The total insertion loss of a single cavity will be approximately that of the calibrated decal. To set the cavity to a particular insertion loss, align the marks on both connector discs to the insertion loss desired. For example, if 1 dB insertion loss is desired, set both loops to the 1 dB mark. Both loops must be set to the same insertion loss mark for proper impedance match (VSWR).

The total insertion loss of a multiple cavity filter is approximately the sum of the losses of the individual cavities. For example, if a 1.5 dB insertion loss is desired for a three cavity filter, the loop settings of the individual cavities should be at 0.5 dB.

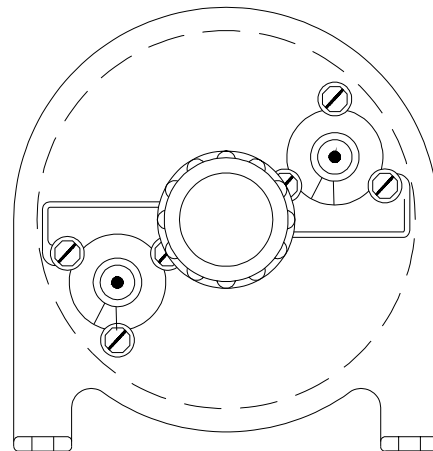

Figure 2 - Typical 5" Cavity

