

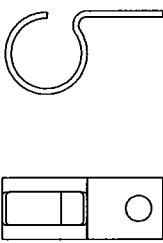

DRAWN D.PERRY DATE 8-29-69 RELEASED R.C.TROTT DATE 4-3-70		REV. E 090014-000	
TITLE: CABLE TERMINAL ASSY INSTRUCTIONS			
GROUND CLAMP  018100-001	BRASS EYELET  007057-001	TERMINAL LUG  007063-001	
		CUT CABLES TO PROPER DIMENSIONS AS SHOWN	
		POSITION CLAMP OVER BRAID SO THAT EDGE IS EVEN WITH CUT END OF BRAID. INSERT EYELET UNDER BRAID UNTIL FLANGE IS FLUSH WITH CLAMP. CRIMP CLAMP TO HOLD IN PLACE. SOLDER EYELET AND CLAMP TO BRAID.	
		PLACE LUG ON CENTER CONDUCTOR AS SHOWN AND CRIMP. SOLDER AS INDICATED IN ILLUSTRATION. APPLY SCOTCH KOTE TO DIELECTRIC PER. SPEC (091030-000)	
		TAPE ENTIRE ASSEMBLY. APPLY SCOTCH KOTE TO ASSEMBLY. (002001-101)	
A ECN 2718 12-21-81 ADD SCOTCHKOTE NOTE	DECIBEL PRODUCTS DALLAS, TEXAS		SHEET 1 OF 2

REV: E 090014-000

DRAWN D.MARR DATE 1-30-70  
 RELEASED DATE

TITLE: CABLE TERMINAL ASSY INSTRUCTIONS

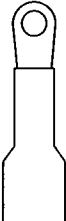
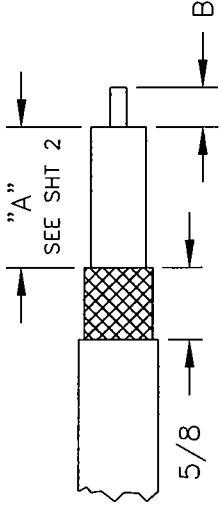
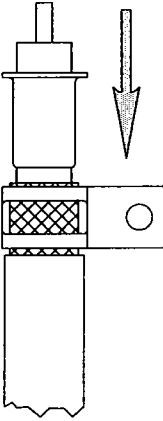
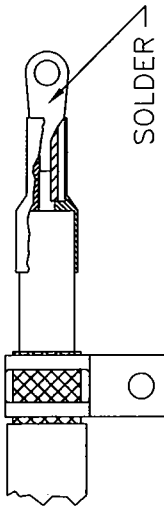
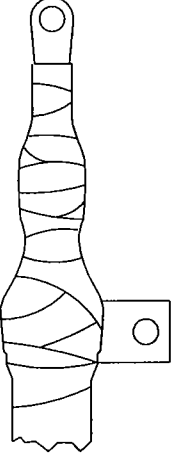
TYPE	DIM "A"	DIM "B"
DB214 H.B.	1-3/4	3/8
DB212 L.B.	1-3/4	1/4
DB225 L.B. & 70MC	2-1/4	3/8
DB230 H.B.	2-5/8	3/8
DB286 H.B.	7/8	3/8
DB230 L.B. DB286 L.B. DB214 L.B.	1-1/8	3/8
DB222/224/228 DB304 DB404 & DB408	1-3/4	3/8
DB220 HB & LB		

E	ECN B7068U ADDED DB304 9-19-02 CS MW
D	ECN B0553U FIX TABLE INFORMATION. 12-05-98DGS MW
C	ECN 3576 ADD 002001-010 TO 4th INSTRUCTION ON PAGE 1 12-4-84DR
B	ECN 3206 1-20-84 ADD DIM-B

DECIBEL PRODUCTS  
DALLAS, TEXAS

SHEET 2 OF 2