

A six-cavity duplexer for use with a two-meter repeater. The cavities are fastened to a plywood base for mechanical stability. Short lengths of double-shielded cable are used for connections between individual cavities. An insertion loss of less than 1.5 dB is possible with this design.

A Homemade Duplexer for 2-Meter Repeaters

Good Isolation at 600-kHz Spacing

BY JOHN J. BILODEAU,* WIGAN

ONE OF THE MAJOR technical problems encountered in putting a repeater on the air is obtaining sufficient signal isolation between the receiver and the transmitter. Many of the solutions to this problem involve a compromise in receiver sensitivity, transmitter power output, and imbalance between receiver and transmitter coverage. When a duplexer** is used, the compromise is in the form of insertion loss. Any disadvantage caused by the small insertion loss is more than offset by the use of one antenna for both transmitting and receiving, thereby assuring equal coverage for both.

Duplexers have been in use by many commercially operated repeaters for quite a number of years.^{1,2} Many of these systems use a frequency separation of 2-percent or more between input and output channels. Most amateur repeaters in the 2-meter band have a frequency separation of only 0.4 percent. The problem of providing good isolation gets more complex as the frequency separation decreases.^{3,4,5} The requirements for a

* 4 Ord Street Court, Salem, MA 01790.

** [EDITOR'S NOTE: A Duplexer is a device that will allow simultaneous transmission and reception while using the same antenna. A Duplexer will permit the use of two transmitters with a common antenna.]

¹ Bryson, "Design of High Isolation Duplexers," *IEEE Transactions on Vehicular Communications*, March, 1965.

² Tilston, "Simultaneous Transmission and Reception with a Common Antenna," *IEEE Transactions on Vehicular Communications*, August, 1962.

³ O'Brien, "Improving the Fm Repeater Transmitter for Amateur Use," *Ham Radio*, October, 1969.

⁴ Epp, "Plain Talk About Repeater Problems," *Ham Radio*, March, 1971.

⁵ Tilton, "A Trap Filter Duplexer for 2-Meter Repeaters," *QST*, March, 1970.

duplexer can be summed up as follows: It must attenuate the transmitter carrier so that it does not overload the receiver and thereby reduce its sensitivity. It must also attenuate any noise or spurious frequencies from the transmitter on or near the receive frequency.^{6,7} In addition, a duplexer must provide a proper impedance match between transmitter, antenna, and receiver. Fig. 1 will help the reader to visualize these functions. Transmitter output on 146.94 MHz going from point C to D should not be attenuated. However, the transmitter energy should be greatly attenuated between points B and A. Duplexer section 2 should attenuate any noise or signals that are on or near the receiver input frequency of 146.34 MHz. For good reception the noise and spurious signal level must be less than -130 dBm (0 dBm = 1 milliwatt into 50 ohms). Typical transmitter noise 600 kHz away from the carrier frequency is 80 dB below the transmitter power output. For 60 watts of output (+48 dBm), the noise level is -32 dBm. The duplexer must make up the difference between -32 and -130 dBm or -98 dBm.

The received signal must go from point B to A with a minimum of attenuation. Section 1 of the duplexer also must provide enough attenuation of the transmitter energy to prevent receiver overload. For an average receiver, the transmitter signal must be less than -30 dBm to meet this requirement. The difference between the transmitter output of +48 dBm and the receiver overload point of -30 dBm must be made up by duplexer section 1.

One thing that many duplexers have in common is the use of high-Q coaxial cavities. The loaded Q of a cavity is affected by electrical conductivity

⁶ Gifford, "The Knee of the Nose," *IRE Transactions on Vehicular Communications*, June, 1954.

⁷ Shepherd and Smith, "The Gaussian Curse — Transmitter Noise Limits Spectrum Utilization," *IRE Transactions on Vehicular Communications*, April, 1958.

and dielectric losses. Surface loss can be reduced by silver plating, although clean copper is adequate. Air-dielectric cavities are the most practical for use in amateur duplexers.

The Circuit

A 1/4-wavelength resonator was selected for this duplexer design. The length of the center conductor is adjusted by turning a threaded rod, thereby tuning the cavity to frequency. Energy is coupled into and out of the tuned circuit by the coupling loops extending through the top plate. The cavity functions as a series-resonant circuit. When a capacitor or inductor is connected across a series-resonant circuit, an antiresonant notch is produced, and the resonant frequency is shifted. The addition of a capacitor across the cavity causes the notch to occur below the resonant frequency. Addition of an inductance will cause the notch to appear above the resonant frequency. The value of the capacitor or inductor will determine the spacing between the notch and the resonant frequency.

Fig. 2 shows the bandpass characteristics of the cavity with shunt elements. With the cavity tuned to 146.94 MHz, and a shunt capacitor connected from input to output, a signal at 146.34 was attenuated 35 dB. With a cavity having an inductance across it, and tuned to 146.34, the attenuation at 146.94 was 35 dB. Insertion loss in both cases was 0.4 dB. Three cavities with a shunt capacitor were tuned to 146.94 and connected with short lengths of coaxial cable. The attenuation of 146.34 was more than 100 dB, while insertion loss was 1.5 dB. Response curves for a six-cavity duplexer are given in Fig. 3. The schematic diagram for the complete duplexer is shown in Fig. 5.

Construction

Three parts for each cavity must be machined; all others can be made with hand tools. A small lathe for metal work will be adequate for the machine work on the brass top-plate, the threaded tuning-plunger bushing, and the Teflon insulator

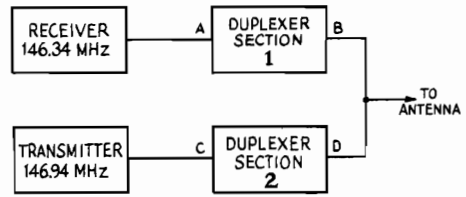

Fig. 1 — Duplexers are used to permit using one antenna for both transmitting and receiving. Section 1 prevents transmitter energy from interfering with the receiver, while section 2 keeps the received signal from reaching the transmitter.

bushing. The dimensions to which these parts must be machined are given in Fig. 4.

Type "DWV" copper tubing is used for the outer conductor of the cavities.[†] The wall thickness is .058 inch, with an outside diameter of 4-1/8 inches. At the time of purchase of the tubing, it would be wise to borrow a tubing cutter large enough to cut this size tubing to the correct length. The wheel of the cutter should be tight and sharp, and the cuts should be made slowly and with care so the ends will be square. The outer conductor is cut to a length of 22-1/2 inches.

The inner conductor is made from type "M" copper tubing having an outside diameter of 1-3/8 inches. A piece of 1-inch OD brass tubing, 6 inches long, is used to make the tuning plunger.

Soft solder is used throughout the assembly. Silver solder is not recommended unless the builder has extensive experience with its use. Eutectic type 157 solder with paste or acid flux will provide very good joints. This type has a slightly higher melting point than ordinary lead-tin alloy but has considerably greater strength.

[†] [EDITOR'S NOTE: The tubing types, such as DWV or M, are designations used in the plumbing or steamfitting industry. Other types may be used in the construction of a duplexer, but the builder should check the sizes carefully to assure that the parts will fit each other. Tubing with a greater wall thickness will make the assembly heavier, and the expense will increase accordingly.]

Fig. 2 — Typical frequency response of a single cavity of the type used for the duplexer. The dotted line represents one cavity alone, while the solid line is for a cavity with a shunt capacitor connected between input and output. An inductance connected in the same manner will cause the rejection notch to be above the frequency to which the cavity is tuned.

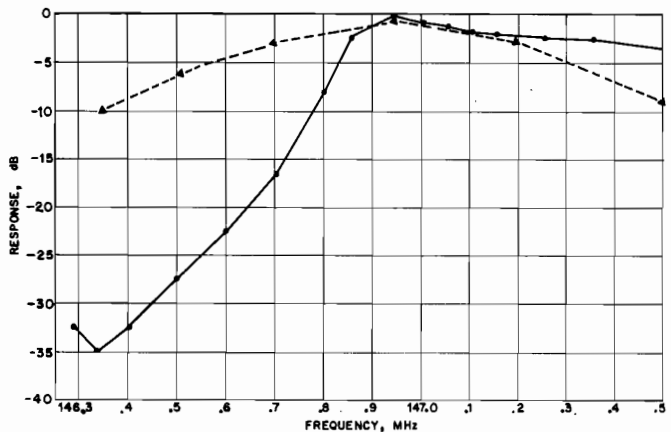

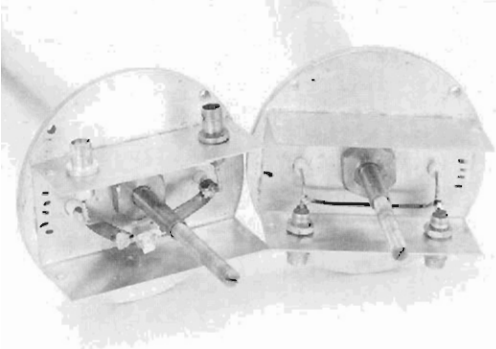

Two of the center conductor and top plate assemblies. In the unit on the left, C1 can be seen just below the tuning shaft. It is mounted by means of short straps made from sheet copper. The assembly on the right has L1 in place between the BNC connectors. The Miniboxes were fastened to the top plate by a single large nut in these examples. The method described by the author, that of using screws through the Minibox into the top plate, should be used for simplicity.

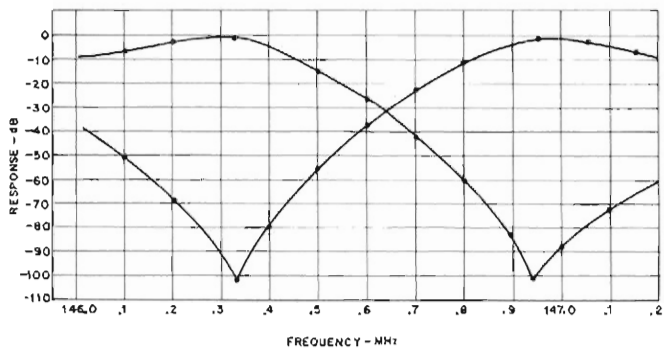
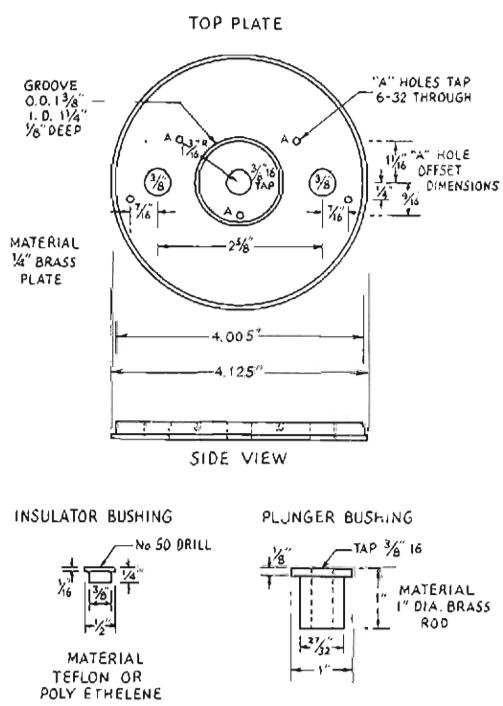

Fig. 3 - Frequency response of a six-cavity duplexer tuned for 146.34-MHz reception and 146.94-MHz transmission.



The inner conductor should be soldered to the top plate first. Then the finger stock can be soldered inside the lower end of the inner conductor, temporarily held in place with a plug made of aluminum or stainless steel. Do not allow the flame from the torch to overheat the finger stock while performing the soldering operation. The plunger bushing is soldered into the tuning plunger and a 20-inch length of threaded rod is soldered into the bushing.

Cut six slots in the top of the outer conductor. They should be 5/8-inch deep and equally spaced around the tubing. The bottom end of the 4-inch tubing is soldered to the square bottom plate. The bottom plates have holes in the corners so they can be fastened to a plywood base by means of wood screws. Because the center conductor has no support at one end, the cavities must be mounted vertically.

The size and position of the coupling loops is critical and the dimensions given should be followed closely. Both loops should be 1/8 inch away from the center conductor on opposite sides. A solder lug should be connected to the ground end of the loop and fastened to the top plate with a screw. The free end of the loop is insulated by Teflon bushings where it passes through the top plate to connect to the BNC fittings.

Fig. 4 - Dimensions for the three parts that require machining. A small metal working lathe should be used.

Fig. 5 — Diagram of the six-cavity duplexer. Coaxial cable lengths between sections are critical and should be followed closely. Double shielded cable should be used. The size and shape of the coupling loops, L1, and the straps for connecting C1 should be observed. C1 is set at 3/4 closed for initial alignment.

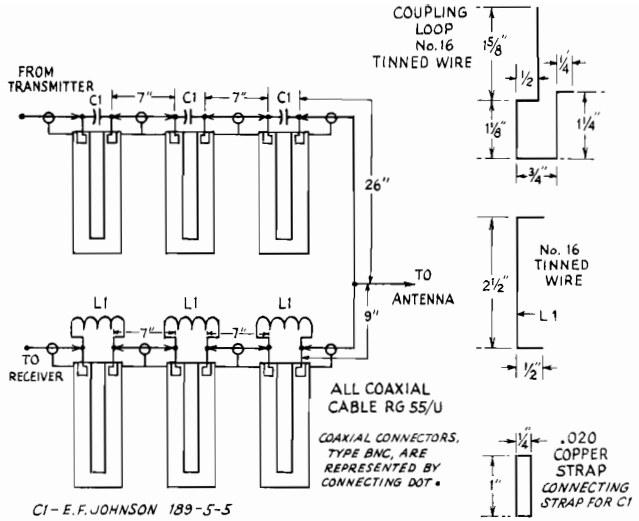

Before final assembly of the parts, they should be cleaned thoroughly. Soap-filled steel wool pads and hot water should do a fine job. The finger stock should be checked to see that it makes a firm contact with the tuning plunger. The top plate should fit snugly in the top of the outer conductor. A large hose clamp tightened around the outer conductor will fasten the top plate in place.

Tuning

The antiresonant elements, C1 and L1, should not be installed until the cavities have been checked for band-pass and insertion loss as shown by the curve in Fig. 2. The preferred method of tuning the duplexer requires the use of laboratory test equipment to obtain the most accurate measurements. A second method to be described uses a low-power transmitter with an rf detector and a VTVM. Fig. 6 shows the connections for both methods.

With the test equipment connected as shown in Fig. 6A, adjust the signal-generator frequency to the desired repeater input frequency. Connect a calibrated step attenuator between points X and Y. With no attenuation, adjust the HP415 for zero on

the 20-dB scale. The calibration of the 415 can be checked by switching in different amounts of attenuation and noting the meter reading. A small error may be noted at either high or very low signal levels.

Remove the step attenuator and replace it with a cavity that has the shunt inductor, L1, in place. Adjust the tuning screw for maximum reading on the 415 meter. Remove the cavity and connect point X to Y. Set the signal generator to the repeater output frequency and adjust the 415 for a zero reading on the 20-dB scale. Reinsert the cavity between X and Y and adjust the cavity tuning for minimum reading on the 415. The notch should be sharp and have a minimum depth of -35 dB. It is important to maintain this minimum reading on the meter while tightening the locknut on the tuning shaft.

To check the insertion loss of the cavity, the output from the signal generator should be reduced, and the calibration of the 415 meter checked on the 50-dB expanded scale. Use a fixed 1-dB attenuator to see if the error is less than 0.1 dB. Replace the attenuator with the cavity and read the loss. The insertion loss should be 0.5 dB or less. The procedure is the same for tuning all six

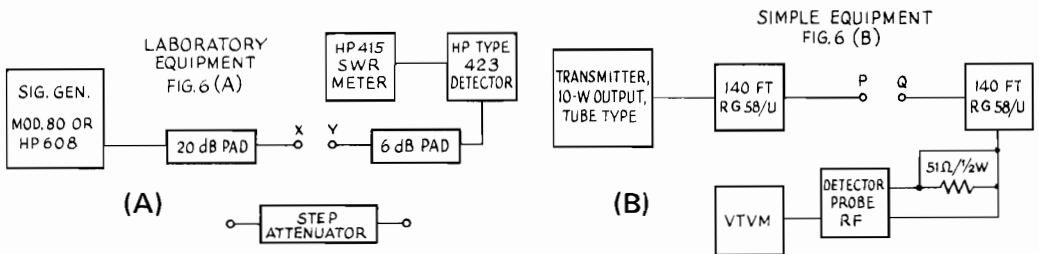

Fig. 6 — The duplexer can be tuned by either of the above two methods, although that of A is the more accurate. The signal generator output should be modulated by a 1000-Hz tone. If the simple equipment as in B is used, the transmitter should not be modulated and should have a minimum of noise and spurious signals. The cavities to be aligned are inserted between X and Y in A and between P and Q in B.

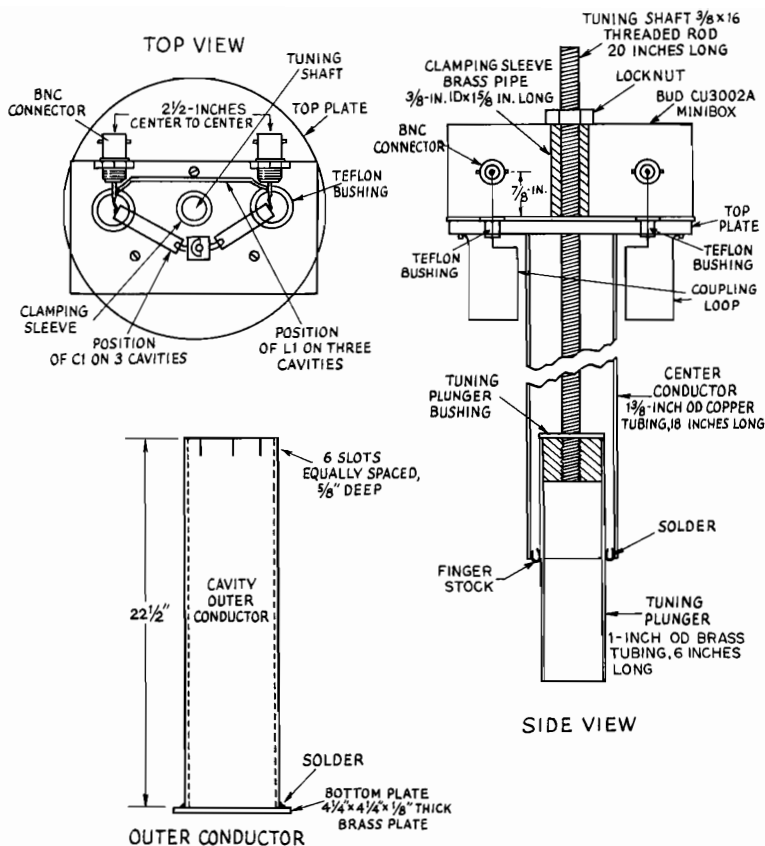

Fig. 7 — The assembly of an individual cavity. A Bud Minibox is mounted to the top plate by means of three screws. A clamping sleeve made of brass pipe is used to prevent crushing the box when the locknut is tightened on the tuning shaft. Note that the position of both C1 and L1 is shown, but that three cavities will have C1 installed, and the others will have L1 in place.

cavities, with the exception that the frequencies are reversed for those that have the shunt capacitor installed.

Adjustment with Minimum Equipment

A transmitter using tubes is preferred for this method of adjustment to assure a minimum of spurious signals that would cause false indications. The VTVM should be capable of reading 0.5 volt or less, full scale. The rf probe should be good to 100 MHz or higher. Sections of RG-58/U coaxial cable are used as attenuators, as shown in Fig. 6B. The loss in these 140-foot sections is near 10 dB and will help isolate the transmitter in case of mismatch during the tuning procedure. The transmitter should be set on the repeater input frequency and P connected to Q. Obtain a reading between 1 and 3 volts on the VTVM. Insert a cavity with shunt capacitors in place between P and Q and adjust the cavity tuning for minimum reading on the VTVM. The reading should be between .01 and .05 volt. Rejection in dB can be calculated by the formula $20 \log V1/V2$ and should be -35 dB, minimum. Insertion loss can be checked by putting the transmitter on the repeater

output frequency and noting the VTVM reading with the cavity in and out of the circuit. A 0.5-dB attenuator can be made from 7 feet of RG-58/U. This 7-foot section can be used to check the calibration of the detector probe and the VTVM. Cavities using a shunt inductance can be tuned in the same manner but with the frequencies reversed. Transmitter noise can cause the rejection readings to be low (less attenuation) if an attempt is made to tune two or more cavities connected together.

Results

At the time of this writing, there are at least 12 of these duplexers in operation in New England. Some of them are in unheated buildings and are subjected to extreme temperature excursions. No serious change in repeater performance was noted. One cavity was checked during a temperature change from 0 to +80°F (I could not fit the whole duplexer in the refrigerator). Rejection changed from -36 dB to -34 dB.

The duplexer is conservatively rated at 150-watts input, but it should be able to withstand up to 300 watts. Silver plating of the interior of

(Continued on page 47)

A Homemade Duplexer

(Continued from page 26)

the cavities is recommended if more than 150 watts of input to the duplexer is planned. A duplexer using plated cavities has shown an insertion loss of under 1 dB, and a rejection of more than -100 dB. Unplated cavities should be taken apart every two years and cleaned thoroughly, then retuned.

Miscellaneous Notes

1) Double-shielded cable is a *must* throughout the system.

2) The VSWR from the antenna should not exceed 1.2 to 1 for proper duplexer performance.

3) Good shielding of the transmitter and receiver at the repeater is essential.

4) The antenna should have four or more wavelengths of vertical separation from the repeater.

5) Conductors in the near field of the antenna should be well bonded and grounded to eliminate noise.

6) The feed line should be well bonded and secured to the tower or mast.

7) Feed lines from other antennas in the near field of the repeater antenna should be well bonded and as far from the repeater as possible.

8) Individual cavities can be used to improve the performance of split-antenna or split-site repeaters.

9) Individual cavities can be used to help solve intermod problems.

10) The notch and pass frequencies of the duplexer are broad enough that two repeaters on adjacent channels could be run through one duplexer and antenna, with the addition of appropriate circulators.

Acknowledgements

The author wishes to thank Lew Collins, K4GGI, for review and comments on the manuscript and Fred Cunningham, W1DCD, for photography and corrections.