

Table of Contents

<u>Chapter</u>		<u>Page</u>
1.	Introduction and Specifications	1-1
2.	Interfacing to Repeater	2-1
3.	Configuration Programming	3-1
4.	Drawings	4-1
5.	Schematics	5-1
6.	Parts List	6-1

REVISED 04/02/02 (V2.01)

Chapter 1 - Introduction and Specifications

WX-1000 Weather Receiver

The WX-1000 is a highly sensitive, quality receiver, with good front-end protection designed to function in the high RF environment typical of many repeater sites. A digital decoder responds to Specific Area Message Encoded (SAME) alerts transmitted by the NOAA weather station located in your geographic area. Select your county code and the type of alert. Select warnings and or watches. During a weather alert, a relay in the WX-1000 will disconnect the transmitter from the controller and connect it to the weather receiver. The relay provides a ground for the transmitter PTT line. Weather audio will be transmitted for the period of the alert announcement. A programmable alert timer provides back-up protection.

Weather Alert Log

As alerts are received the WX-1000 stores the date, time and type of alert in non-volatile memory. Storage space is provided for forty alerts. Use the RS-232 port and the WX-1000 configuration program to down load the data. A print driver is also provided.

Front Panel Controls And Displays

Two toggle switches control weather receiver operation. The MONITOR switch activates the speaker. The VOLUME control includes the power switch and adjusts the speaker output level. The red ALERT LED flashes when an alert is received. This LED will continue to flash until the alert period has expired or the spring loaded RESET switch is pressed. The RESET switch has two functions during an active alert. A short activation then release will voice the present alert. A long activation (longer than one second) then release will cancel an alert. **NOTE: The MONITOR switch must be down to receive weather alerts.**

Alert Start Logic Output (J3-7)

An ALERT START output provides a TTL logic high two second pulse when a weather alert is received. This output can be used to set off an external alarm or trigger the controller to execute a macro or load a "SEVERE WEATHER ALERT" memory save.

Alert Stop Logic Output (J3-6)

Included in the digital packet is the length of the severe weather alert. The WX-1000 stores this information and generates a stop logic output when the time period has expired. An ALERT STOP output provides a TTL logic high for one second. This output can be used to trigger the controller to reload the "NORMAL" memory save.

Weather Enable Input (J3-9)

When this input is grounded the weather receiver will activate. When connected to a controller's user function output switch, weather reports on demand are available.

Weather Disable Input (J3-4)

When this input is grounded the WX-1000 will not respond to weather alerts issued by the NOAA weather station. Once a "Sky Warn Net" is activated, it may be desirable to stop any additional alerts.

Weather Reset Input (J3-12)

Momentary grounding this input will reset the WX-1000 receiver terminating the alert and message. Note: From the "WX-1000 Hardware Inputs Outputs" window dot the circle to select "Cancel any activate alerts."

Alert Message Timer Selection

At the conclusion of an alert message the weather station send a digital termination packet. The WX-1000 decodes this packet and turns the transmitter off. If the weather station fails to send the termination packet the alert message timer will take over. Select this time with the WX-1000 configuration program.

Specifications

Available NOAA Channels:	162.400 MHz, 162.425 MHz, 162.450 MHz, 162.475 MHz 162.500 MHz, 162.525 MHz, 162.550 MHz
Sensitivity Receive:	0.5 microvolts for 20 dB quieting
Sensitivity Decoder:	1.0 microvolts for 95% decoder accuracy
Image Rejection:	-55dB
I.F. Rejection:	-60dB
Modulation:	Narrow Band FM, 5KHz Deviation
Antenna:	50 Ohm, Type BNC Connector
L.O. Emissions:	Fully complaint with FCC Rules, Part 15
Relay Closure:	2 Form C (DPDT) by Digital Alert Packet
Power:	+12VDC @ 120 ma, DC Power Type 2.5mm
Front Panel Control:	Monitor, Reset, Power ON-OFF/Volume
Front Panel LEDs:	Green (Power), Red (Alarm)
Dimensions:	3.5" H x 19" W x 7" D
Operating Temperature:	-15 to +55 C

FCC Part 15 RF Interference

This device complies with part 15 of the FCC Rules. Operation is subject to the following two conditions: (1) This device may not cause harmful interference, and (2) this device must accept any interference received, including interference that may cause undesired operation.

FCC Part 97.113.e Prohibited transmissions.

No station shall retransmit programs or signals emanating from any type of radio station other than an amateur station, except propagation and weather forecast information intended for use by the general public and originated from United States Government stations.

Chapter 2 - Interfacing to Repeater

CAT-1000 Interface

Connect the WX-1000 to the CAT-1000 and the repeater as shown in Figure 2-1. PTT and transmit audio from the CAT-1000 are connected to the repeater's transmitter through the normally closed contacts of the double pole double throw relay located in the WX-1000. Set the power switch to on, the WX-1000 will announce the firmware version. When a weather alert is received, the relay will switch the weather alert audio to the TX audio input and provide a PTT signal to key the transmitter.

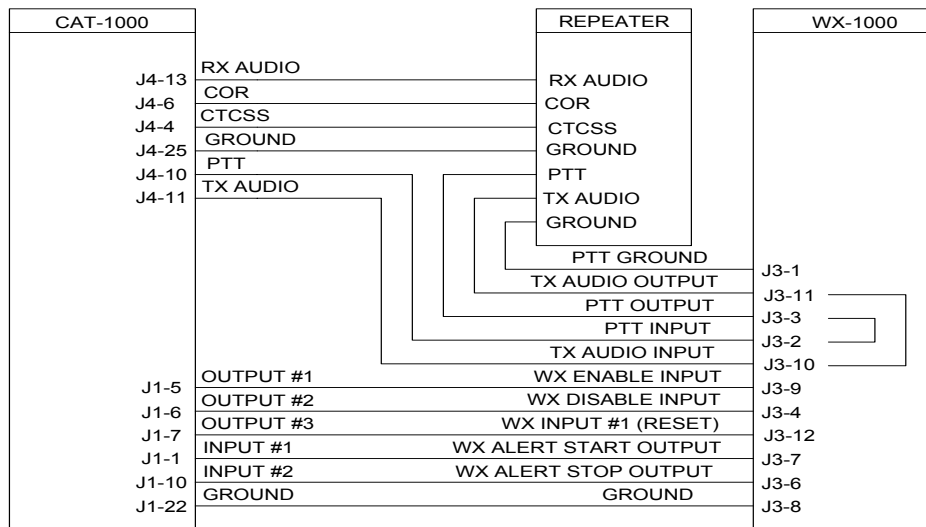

Figure 2-1

The WX-1000 receiver can be activated at anytime, by turning on the CAT-1000 user function output #1 which grounds the WX ENABLE pin (J3-9) on the WX-1000 receiver. Key-up and enter: [100811]. To stop the broadcast key-up and enter: [100810].

It may be desirable to stop additional alerts when a skywarn net is activated. Turn on the CAT-1000 user function output #2. This grounds the WX DISABLE pin (J3-4) on the WX-1000. Key-up and enter: [100821]. To activate the weather receiver, key-up and enter: [100820].

When a weather alert is received, the WX ALERT START OUTPUT (J3-7) will provide a two second positive DC voltage [TTL] level to the CAT-1000 at INPUT #1. Program this input to load a memory save pre-programmed for "several weather" conditions. Follow the example: Unlock the controller and program INPUT #1 to load memory save #4 by entering [*171 5204]. Control operator Zone 7 Channel 1 must be enabled for INPUT #1 to function.

Included in the alert packet is the length of the alert. When the alert time has expired, the WX ALERT STOP OUTPUT (J3-6) will provide a one second positive DC voltage [TTL] level to the CAT-1000 at INPUT #2. Program this input to load a memory save pre-programmed for "normal" conditions. Follow the example: Unlock the controller and program INPUT #2 to load memory save #1 by entering [*171 5201]. Control operator Zone 7 Channel 2 must be enabled for INPUT #2 to function.

NOTE: Do not operate the CAT-1000 repeater controller with Zone 7 channels 1 and 2 enabled unless you have programmed memory file #1 with "normal" conditions and memory file #4 with "severe" weather conditions.

The weather bureau usually tests the system every Wednesday between 11 AM and 12 noon. Check with your local weather service office for the exact day and time. The test message will be transmitted on your repeater. However you may not want to load memory file #4 when its just a test. To prevent the memory file load use the scheduler to disable hardware input #1 at 11AM and enable hardware input #1 at 12 noon.

Program scheduler position #1 at 11:00 AM on Wednesday to turn off Zone 7 Channel #1. Unlock the controller. Key-up and enter: [*1101 11 00 4 00 00 1710]. Program scheduler position #2 at 12:00 NOON on Wednesday to turn on Zone 7 Channel #1. Key-up and enter: [*1102 12 00 4 00 00 1711].

Dual Port Repeater Controller Interface (Alternate)

If the WX-1000 is connected to a dual port repeater controller, such as the CAT-1000, CAT-700, CAT-300DXL or the CAT-200, and the second port is not being used, the WX-1000 can be connected as a remote base receiver.

Connect the WX-1000, CAT-1000 and the repeater as shown in Figure 2-2. The WX-1000 transmit audio output becomes the RX Audio #2 of the CAT-1000. The WX-1000 PTT Output becomes the COR #2 input of the CAT-1000. Note: COR #2 is active LOW. Install a 2200-ohm pull-up resistor on the CAT-1000 board at R75 and set dip switch #2 to ON. Key-up and enter the remote base command [5001] to enable port #2.

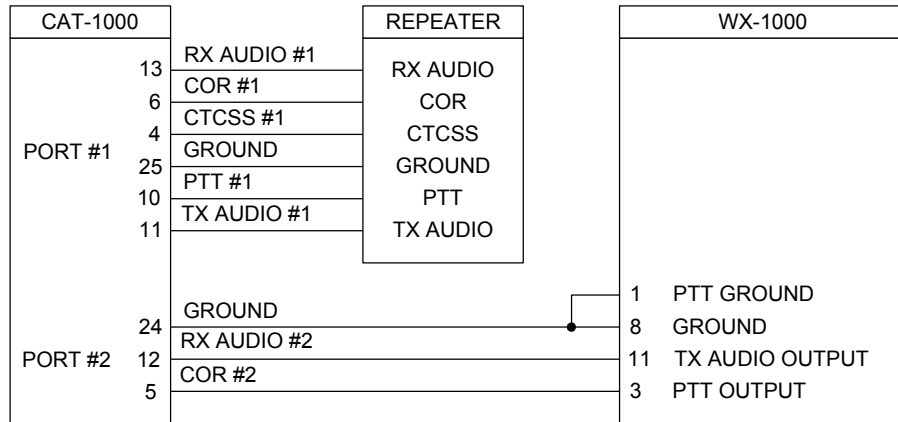

Figure 2-2

CAT-300DX Interface

Connect the WX-1000 to the CAT-300DX and the repeater as shown in Figure 2-3.

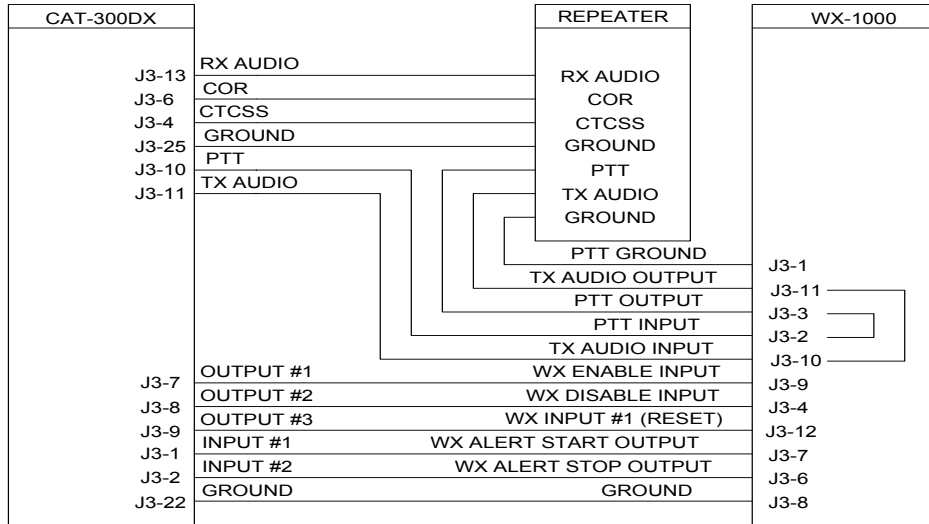

Figure 2-3

The WX-1000 receiver can be activated at anytime, by turning on the CAT-300DX user function output #1 which grounds the WX ENABLE pin on the WX-1000 receiver. Key-up and enter: [100661]. To stop the weather broadcast key-up and enter: [100660].

CAT-700 Interface

Connect the WX-1000 to the CAT-700 and the repeater as shown in Figure 2-4.

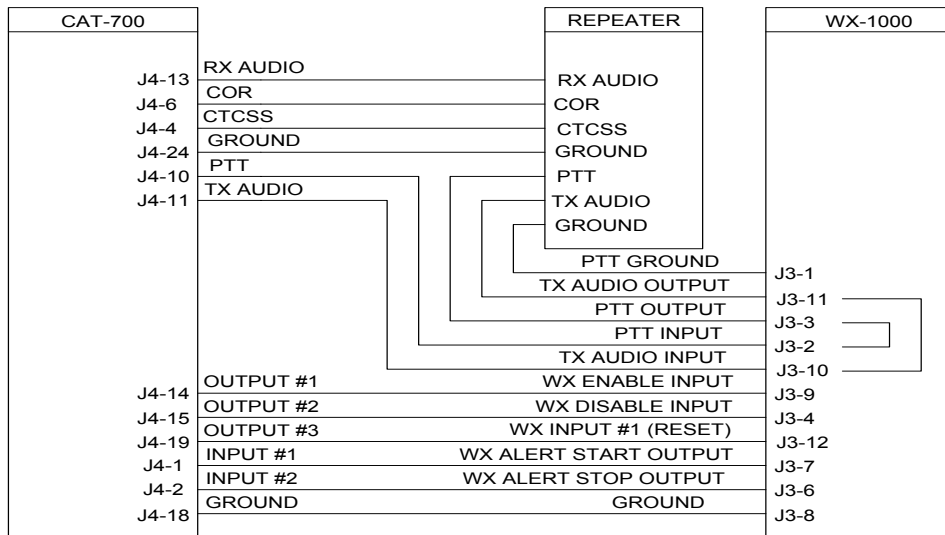

Figure 2-4

The WX-1000 receiver can be activated at anytime, by turning on the CAT-700 user function output #1 which grounds the WX ENABLE pin on the WX-1000 receiver. Key-up and enter: [100551]. To stop the weather broadcast key-up and enter: [100550].

CAT-200 Interface

Connect the WX-1000 to the CAT-200 and the repeater as shown in Figure 2-5.

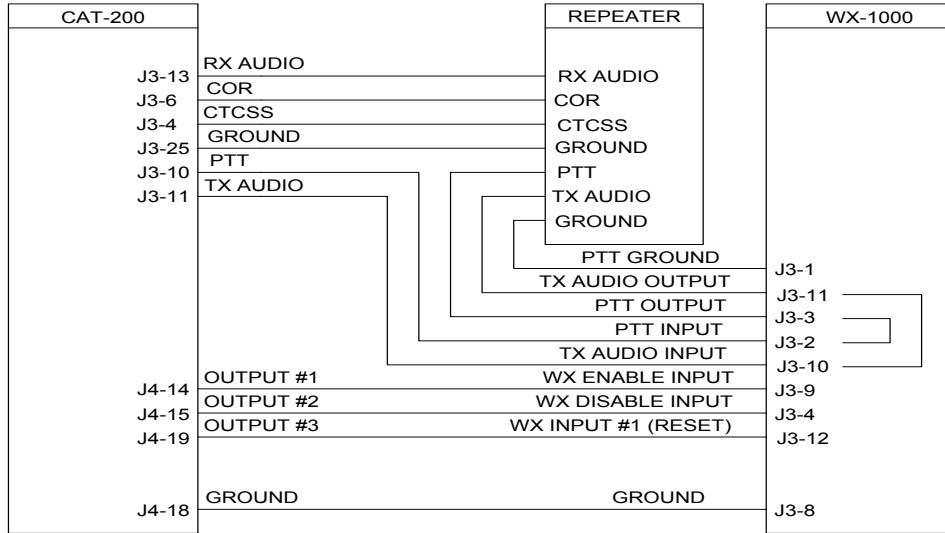

Figure 2-5

The WX-1000 receiver can be activated at anytime, by turning on the CAT-200 user function output #1 which grounds the WX ENABLE pin on the WX-1000 receiver. Key-up and enter: [100351]. To stop the weather broadcast key-up and enter: [100350].

CAT-300DXL Interface

Connect the WX-1000 to the CAT-300DXL and the repeater as shown in Figure 2-6.

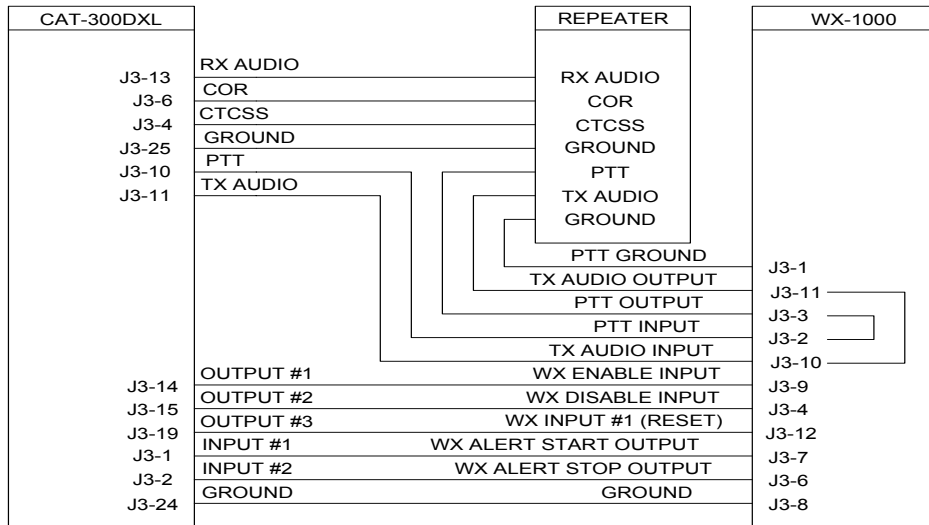

Figure 2-6

The WX-1000 receiver can be activated at anytime, by turning on the CAT-300DXL user function output #1 which grounds the WX ENABLE pin on the WX-1000 receiver. Key-up and enter: [100751]. To stop the weather broadcast key-up and enter: [100750].

Computer Interface J1

Connect your computer's serial port to the WX-1000 receiver at connector J1. Use Radio Shack shielded RS-232 cable (cat No. 26-117B) or equivalent. This cable is a DB-9 male to DB-9 female with pins 2-2 and 3-3.

12VDC Interface J2

Connect a 12VDC power supply to the WX-1000 receiver through the 2.5mm power jack J2. The center pin is positive. In stand-by mode the WX-1000 requires approximately 100 ma.

Repeater Interface PTT Ground [J3-1]

Connect this pin to the transmitter chassis ground. This will insure that during an alert the PTT line will be returned to transmitter chassis ground.

Repeater Interface PTT Input [J3-2]

Connect this pin to the controller PTT output.

Repeater Interface PTT Output [J3-3]

Connect this pin to the transmitter PTT input.

Repeater Interface Weather Alert Disable Input [J3-4]

Connect this pin to a user function switch on the controller. When this input is grounded, the receiver will not respond to alerts issued by the weather station.

Repeater Interface Weather Output #2 [J3-5]

From the "WX-1000 Hardware Inputs and Outputs" window select a one second pulse output "With All Decoded Events", "With Watch or Warning Decoded Events", "With Watch Decoded Events", "With Warning Decoded Events" or "With Non Watch or Warning Decoded Events".

Repeater Interface Weather Alert Stop Output [J3-6]

When a weather alert is received, embedded in the digital message is the length of the alert. When this time period has expired, this output will go active high (TTL) for one second. Connect this pin to a logic input on the controller. Program the controller to load the NORMAL memory file.

Repeater Interface Weather Alert Start Output [J3-7]

When a weather alert is received, this output goes active high (TTL) for two seconds. Connect this pin to a logic input on the controller. Program the controller to load a SEVERE WEATHER memory file.

Repeater Interface Ground [J3-8]

Connect this pin to controller ground. This provides a common ground between the controller and WX-1000 receiver.

Repeater Interface Weather Alert Enable Input [J3-9]

Connect this input to a user function switch on the controller. When this input is grounded, the weather receiver will activate.

Repeater Interface TX Audio Input [J3-10]

Connect this input to the controller transmit audio output.

Repeater Interface TX Audio Output [J3-11]

Connect this output to the repeater transmit audio input.

Repeater Interface Weather Input #1 [J3-12]

Connect this input to a user function switch on the controller. When this input is momentarily grounded the WX-1000 will reset. Note: From the "WX-1000 Hardware Inputs Outputs" window dot the circle to select "Cancel any activate alerts."

Repeater Interface Weather Output #3 [J3-13]

From the "WX-1000 Hardware Inputs and Outputs" window, select the Output #3 tab. From the list of "Rising Edge" events dot the circle of the event you wish to cause output #3 to rise to +5 volts. From the trailing edge list dot the circle of the event you wish to cause output #3 to drop back to 0 volts.

Repeater Interface Weather Output #1 [J3-14]

From the "WX-1000 Hardware Inputs and Outputs" window select a one second pulse output "With All Decoded Events", "With Watch or Warning Decoded Events", "With Watch Decoded Events", "With Warning Decoded Events" or "With Non Watch or Warning Decoded Events".

Repeater Interface Weather Input #2 [J3-15]

After the alert message is sent, the WX-1000 will periodically key the transmitter and send a voice synthesizer announcement. Set the J5 jumper on pins 2 and 3. This connects input #2 to the PTT input. When the PTT input is active low, meaning the repeater is in use, the voice synthesizer announcement will be suppressed. Note: From the "WX-1000 Hardware Inputs Outputs" window dot the circle to select "Skip voice announcements".

Antenna Interface J4

Connect an antenna to the BNC connector J4. If the WX-1000 is located in the fringe area of the NOAA transmitter an external antenna is recommended. Do not locate the antenna near any transmitting antennas.

WX-1000 Frequency Adjustments

The WX-1000 is shipped with its frequency set to 162.550 MHz. To change to a different NOAA frequency, change the settings of dipswitch SW1.

SW1-1	SW1-2	SW1-3	FREQUENCY
OFF	OFF	OFF	162.400 MHz
ON	OFF	OFF	162.425 MHz
OFF	ON	OFF	162.450 MHz
ON	ON	OFF	162.475 MHz
OFF	OFF	ON	162.500 MHz
ON	OFF	ON	162.525 MHz
OFF	ON	ON	162.550 MHz

Figure 2-6

WX-1000 Audio Adjustments

Transmit audio from the controller has a direct connection to the transmitter through the WX-1000. There is no need to readjust transmitter deviation. Set the MONITOR switch on the front panel to on. Monitor the transmitter output. Adjust the LINE LEVEL audio control R25 for the desired level of weather station audio. With the MONITOR switch on, activate the RESET switch.

The voice synthesizer will announce the selected FIP codes and voice the station ID if activated. Continue to cycle the RESET switch as required until the LINE VOICE LEVEL audio control R24 is adjusted for the desired Voice synthesizer level. The SPEAKER VOICE LEVEL audio control R23 has been factory set and should not require any additional adjustments.

Play Test Packets

You can generate test packets with your computer's sound card to test the WX-1000. NOTE: Insure that during the test sequence the sound card is not configured to apply "special effects" to the sound files.

Connect the output of the sound card to the modulation input of a RF signal generator. Set the frequency to 162.XXX MHz at 3KHz deviation. If a signal generator is not available connect a cable from the output of the sound card to WX-1000 at TP2. This is the junction of R9 (10K) and C34 (.015uF).



Figure 2-7

Reset the WX-1000 to the default values. Set the MONITOR switch to ON. Hold the spring loaded RESET switch up and turn on the WX-1000 receiver. Check that the RED ALERT LED flashes.

Start the WX-1000 program, click on the "HELP" menu and select "Play Test Packets". Insure that the MONITOR switch is down and click on one of the TEST buttons to activate the test sequence.

TEST	PREDEFINED DATE	PREDEFINED LENGTH
Required Weekly Test	July 31	15 Minutes
Flash Flood Warning	July 31	1 Hour
Severe Thunderstorm Watch	July 31	1 Hour
Tornado Watch	July 31	1 Hour

Figure 2-8

Each packet contains the following 10 FIP codes:

012099-012011-012025-000000-000000-000000-000000-000000-000000-012999

NOTE: After completion of the test remember to upload your local parameters and codes.

Chapter 3 - Configuration Programming

The WX-1000 Configuration program requires a Windows 95, 98, 2000, NT or Me operating system. Install the program. Press START, PROGRAMS, and WX1000 Weather Receiver to display the [WX-1000 DIGITAL WEATHER RECEIVER] window.

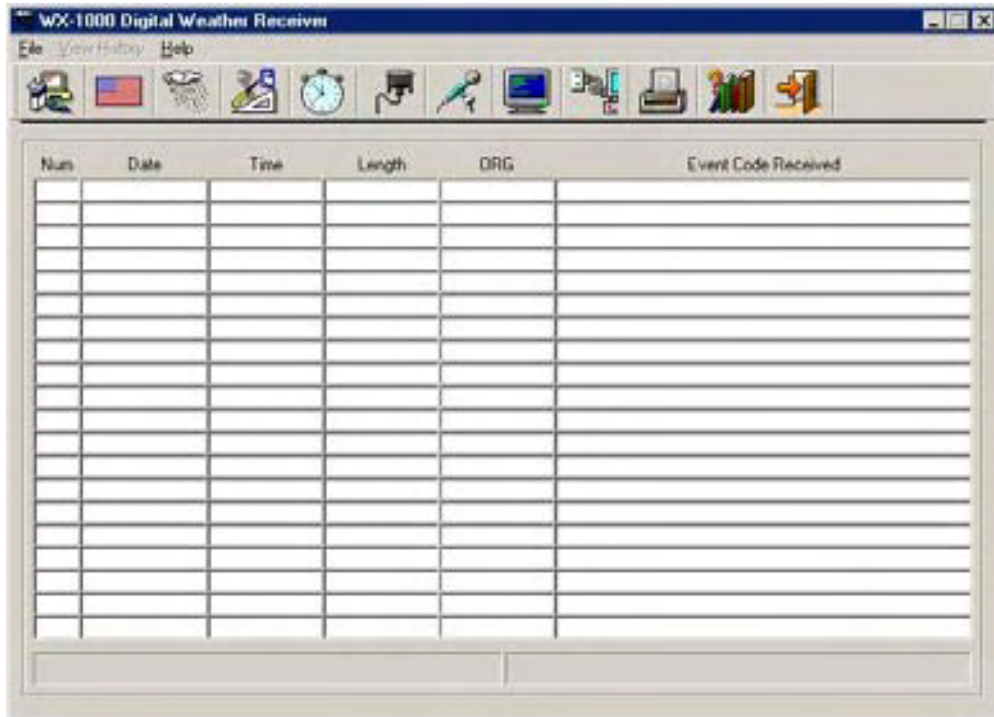

Figure 3-1

WX-1000 Setup

Click the [Program Setup] button to display the [WX-1000 SETUP] window. Select your computer's serial port or click on the "Serial Port Test" button. Your computer will determine which port is connected to the WX-1000. The time of the alert is sent in the digital packet as GMT time. Select your time zone so the configuration program can calculate your local time. Check the box to automatically adjust for daylight savings time. Click [OK].

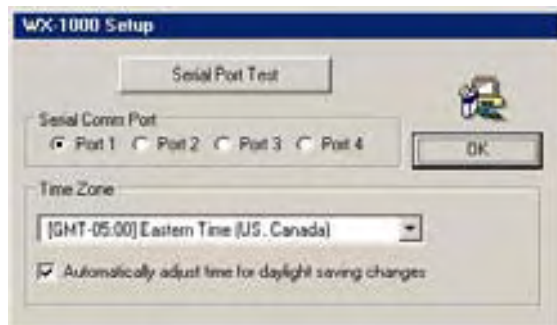

Figure 3-2

Federal Information Processing Codes

From the WX-1000 Digital Weather Receiver window click the [U.S. FLAG] button to display the [WX-1000 FIPS Codes] window. Click the [SELECT STATE / TRANSMITTER CITY] button to display the [WX-1000 STATE / TRANSMITTER LOCATION] window.

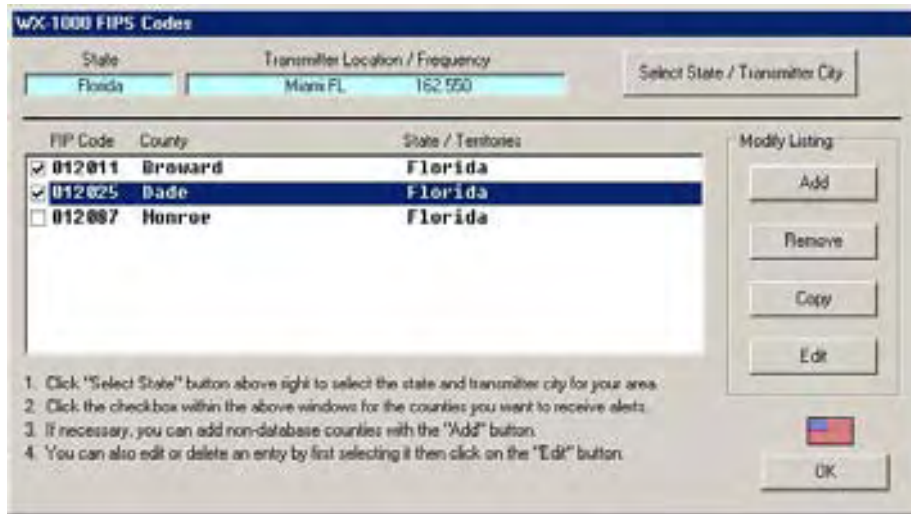

Figure 3-3

WX-1000 State / Transmitter Entry

Select the state and frequency from the drop down boxes. Select the transmitter location and Click [OK].

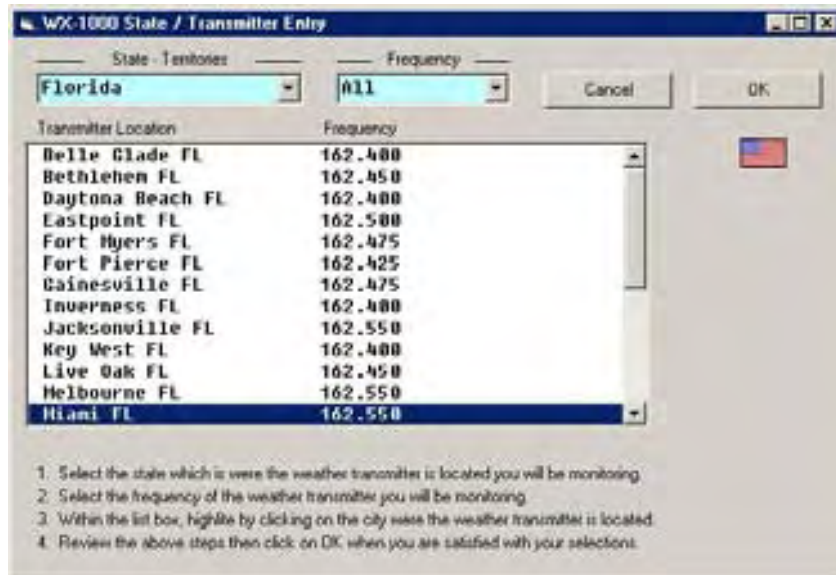

Figure 3-4

The WX-1000 FIPS Codes window will display the counties serviced by the selected transmitter. Select the desired county or counties by checking the boxes along the left column. Up to 24 counties can be selected. When the selections are complete, click [OK] to return to the WX-1000 FIPS Code window.

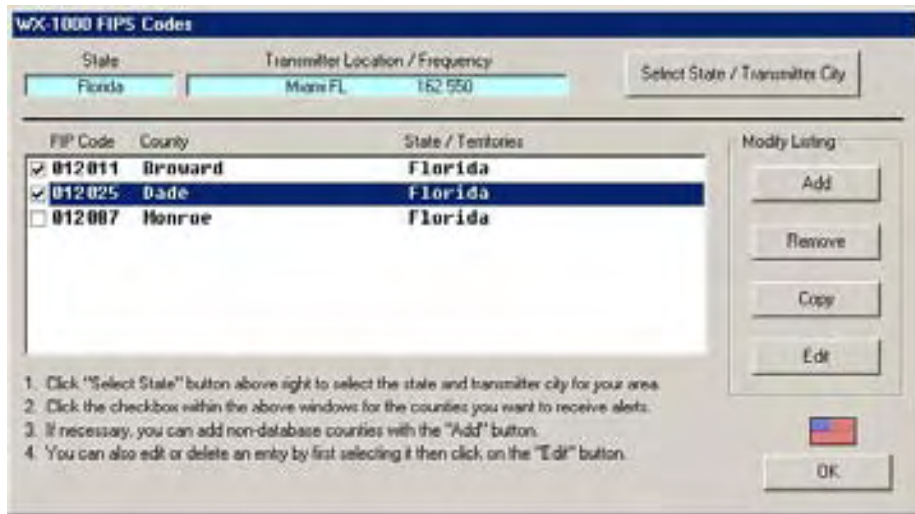

Figure 3-5

FIPS Code Editor

The WX-1000 editor program includes an all states database derived from the database of the NOAA weather service at www.noaa.org. As changes are made by the weather service the all states data file for the WX-1000 editor is up-dated and available on the computer automation web site at www.catauto.com. The WX-1000 FIPS Editor window permits the addition of codes that do not appear on the current published lists. See Figure 3-6.

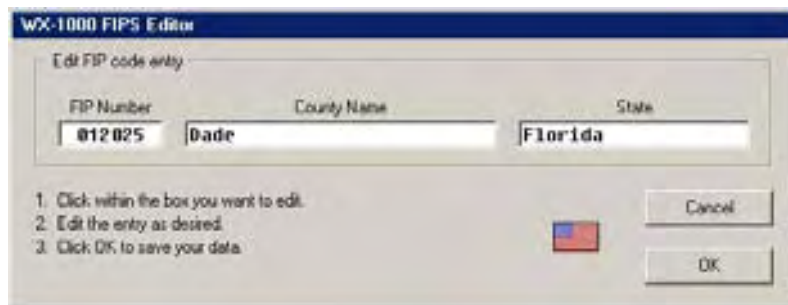

Figure 3-6

WX-1000 Event Codes

Click the [STORM CLOUD] button to display the [WX-1000 EVENT CODES] Window. Select up to twenty-four events by checking the box next to each event. When the selections are complete check OK.



Figure 3-7

WX-1000 Options Settings

Click the [TOOLS] button to display the [WX-1000 OPTIONS SELECT] Window. Options include Received Alert Options, Front Panel Switch Options, Override Options and Voice Interval Options. Select the desired options and click [OK].



Figure 3-8

Received Alert Options

These boxes should be checked to activate the front panel speaker, transmitter and front panel LED.

Front Panel Switch Options

These boxes should be checked for the front panel MONITOR switch to activate the speaker, transmitter and line audio.

Override Options

If the accept all FIP and Event Codes boxes are checked, the WX-1000 will respond to all alerts issued by the weather station. Operation is similar to a receiver with 1050Hz decoder only.

Voice Interval Options

When the alert message is finished the weather station sends a termination data packet. Upon receipt of this packet the WX-1000 will turn off the speaker, line audio and repeater transmitter. The voice synthesizer will continue to announce the alert until the time period has expired. Select the desired voice alert options and click OK.

WX-1000 Timer Settings

Click the [CLOCK] button to display the [WX-1000 TIMER SELECT] Window. Timers include: Speaker Time-out, Line Time-out, Pre Voice Delay Timer, Voice Interval Timer and Relay Activation Delay Timer. Select the desired times and click [OK].

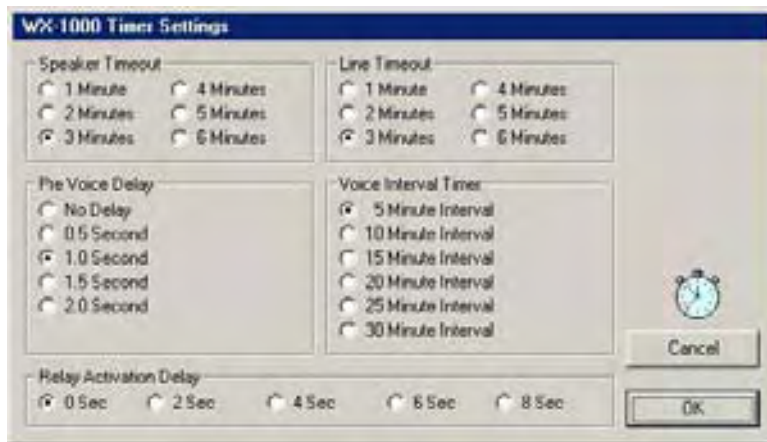

Figure 3-9

Speaker Time-out Option

This timer selects the time the front panel speaker is enabled when an alert message is sent by the weather station. A termination data packet is sent at the end of the alert message to disable the speaker. Should the weather station fail to send the termination data packet this timer will disable the front panel speaker.

Line Time-out Option

This timer selects the time the line audio and PTT outputs are active when an alert message is sent by the weather station. A termination data packet is sent at the end of the alert message. Should the weather station fail to send the termination data packet this timer will limit the alert transmission time.

Pre Voice Delay

This timer selects the delay between activation of the control relay and when the voice synthesizer begins to speak.

Voice Interval Timer Option

Imbedded in the alert information packet is the time the warning or watch is in effect. The time is sent in fifteen-minute increments for the first hour and thirty minute increments for the remaining time of the alert. Once the alert message is finished, the red alert led on the front panel will continue to flash and the WX-1000 voice synthesizer will periodically key-up the repeater transmitter and announce the nature of the alert. This timer sets the time between voice synthesizer announcements.

Relay Activation Delay

When the digital packet is decoded the relay disconnects the transmitter from the controller. If you want to use the features of your repeater's controller to send paging tones, alert tones or a custom voice message announcement this disconnect must be delayed. Use this feature to select the delay.

WX-1000 Hardware Inputs

Click the [CONNECTOR] button to display the [WX-1000 HARDWARE INPUTS AND OUTPUTS] window. Two hardware inputs are provided on the back of the WX-1000 for additional control. Two tab selection dialog boxes can be selected to program how the two inputs will control the WX-1000.

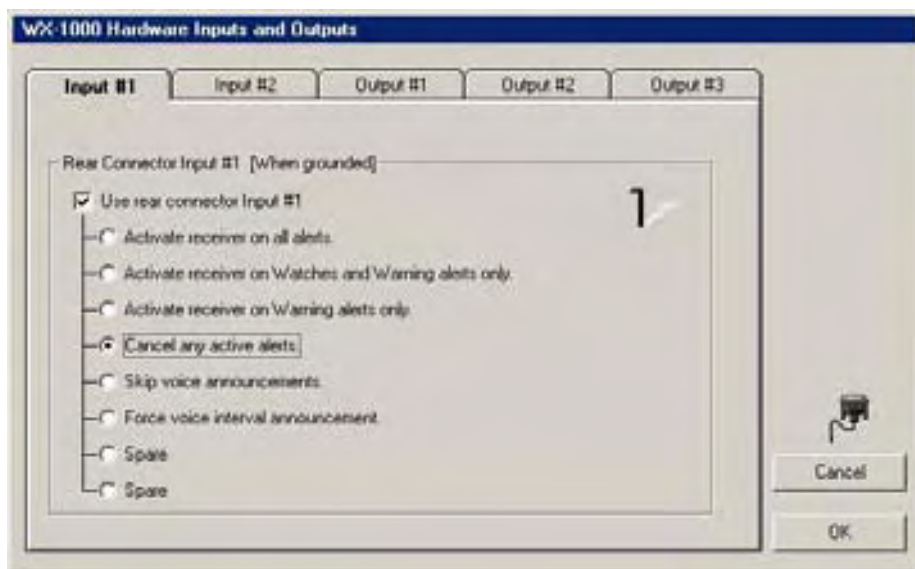

Figure 3-10

Activate Receiver On All Alerts Input [GROUND]

When this input is grounded, the WX-1000 will respond to all alerts issued by the weather station regardless of the event codes programmed into its memory.

Activate Receiver On Watches and Warnings Only Input [GROUND]

When this input is grounded, the WX-1000 will only respond to programmed watches and warnings.

Activate Receiver On Warnings Alerts Only Input [GROUND]

When this input is grounded, the WX-1000 will only respond to programmed warnings.

Cancel Any Active Alert (RESET) Input [PULSE TO GROUND]

When this input is momentary grounded, the WX-1000 will reset, canceling the alert.

Skip Voice Announcement Input [GROUND]

After the alert message has been transmitted the WX-1000 will continue to periodically key the repeater transmitter and send a voice synthesizer announcement describing the nature of the alert. Connect jumper J5 between pins 2 and 3 to connect this input to the PTT input. When the PTT input is active low meaning the repeater is in use, the voice synthesizer announcement will be suppressed.

Force Voice Interval Announcement Input [GROUND]

When this input is grounded, the WX-1000 will announce which event is currently active.

WX-1000 Hardware Outputs

Three hardware outputs are provided on the back of the WX-1000 for additional external controlling. Three tab selection dialog boxes can be selected to program how the three outputs will operate. Outputs #1 and #2 provide pulsed outputs based on the selection as indicated on the dialog box. Output #3 is a TTL level control giving a high and low output of (+5 Volts and 0 Volts) as selected. **Note: These outputs cannot be used as relay drivers.**

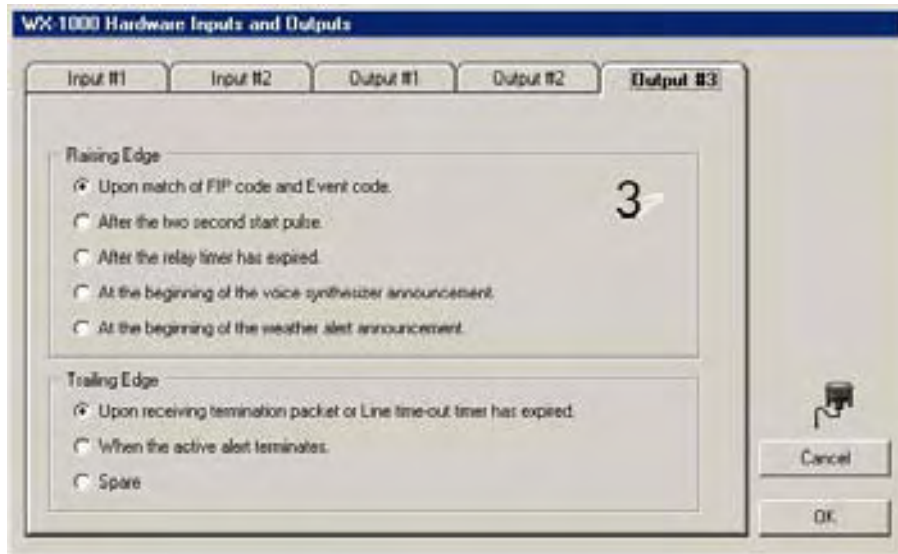

Figure 3-11

Call Letter Identification

Use the WX-1000 voice synthesizer to identify the transmitter at the end of an alert and during the periodic voice weather announcements. Enter your station identification in the Call Letter Box. Valid characters are A-Z and 0-9. Up to fifteen (15) characters can be entered. Additional check boxes are provided to add the words "This is", "Transmitter" and "Repeater" to the identification announcement.

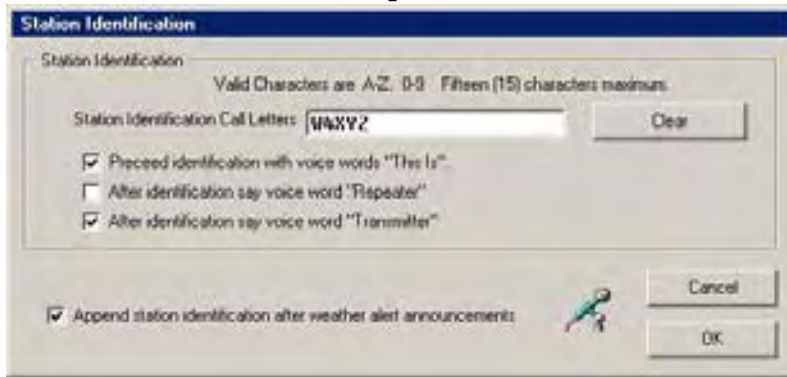

Figure 3-12

Transfer Data

To transfer data between the WX-1000 and your computer, click the [COMPUTER TRANSFER] button. After the current configuration up loads the alert history will down load. The alert history will display in the [WX-1000 DIGITAL WEATHER RECEIVER] window. See Figure 3-13. The most recent alert will appear in group #1 table position #1. The WX-1000 memory will store information on the last forty alerts. The display includes the Date, Time and Event Code description. Warnings are displayed in red, watches in yellow, and test messages in white. **NOTE: The front panel MONITOR switch must be off to transfer data.**

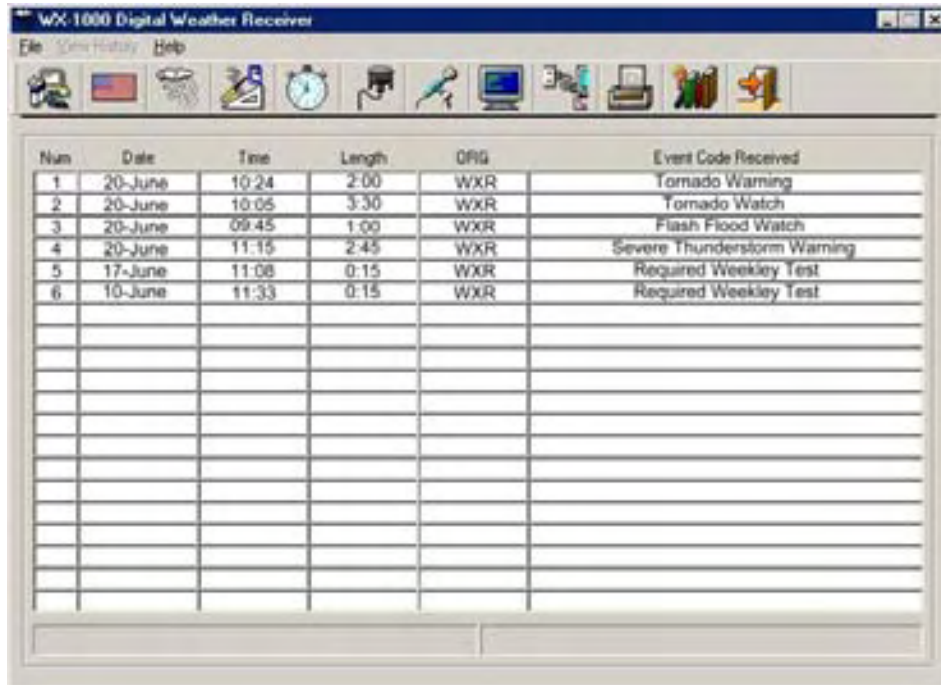

Figure 3-13

Test County FIP Codes

After a data transfer, set the front panel MONITOR switch to on and momentary flip the RESET switch. The voice synthesizer will read out the county FIP codes stored in memory. Example: The voice will say: "WX1000 TEST FIP CODES ARE 013067 013089 013121." The voice synthesizer will also announce the station ID if enabled.

Reset WX-1000 Memory

Turn off the receiver, set the front panel MONITOR switch to on, hold the reset switch up while turning the power on. When the RED alert LED flashes the WX-1000 memory has been reset and filled with default values.

Print History

To print the alert history, click the [PRINT HISTORY] button.

WX-1000 Raw Data Transmission

The WX-1000 will send the raw data as it was received from the weather service as a ASCII string at 4800-baud 8N1. This data may be imported directly into an alpha numeric paging system or interfaced to a computer based alarm system.

To activate this feature click the [COMPUTER TERMINAL] button to display the [RS-232 Rear Port Options] Window. Check the box to send the weather packet out the rear RS232 port. Select the desired options and click [OK]. Check the Append boxes to add special ASCII characters to the raw data dump as necessary.



Figure 3-14

Weather Data Packet

Figure 3-15 describes a typical weather data packet as it is received from the National Weather Service.

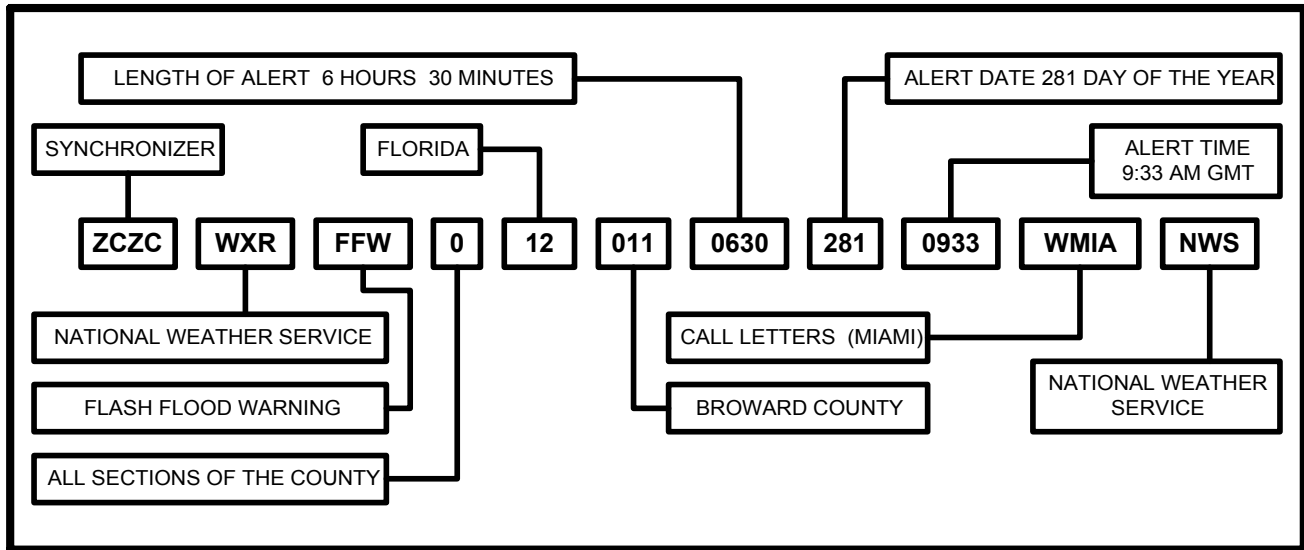

Figure 3-15

Display Internal Parameters

Internal data parameters can be displayed through a special download of data from the WX-1000 receiver and this editor program. To use this feature, insure the WX-1000 is connected to the computer's serial port.

From the main dialog window, hold down the left "Ctrl" keyboard key and left click on the menu help. Release the "Ctrl" key then left click "About" with your mouse. You should now see the "about window" with an additional command button "Data Dump".



Figure 3-16

Click the "DUMP DATA" button to display the WX-1000 Data Dump window. Use this window to receive and display special data from the WX-1000. The four buttons are:

NV Data	Dumps the non-volatile memory data.
RAW Data	Dumps the last raw data as received from the alert transmission.
Clear	Clears out the window.
Save Window	When activated, displayed data will be saved to a file.

Figure 3-17

Click the "RAW DATA" button to display the last alert received by the WX-1000.

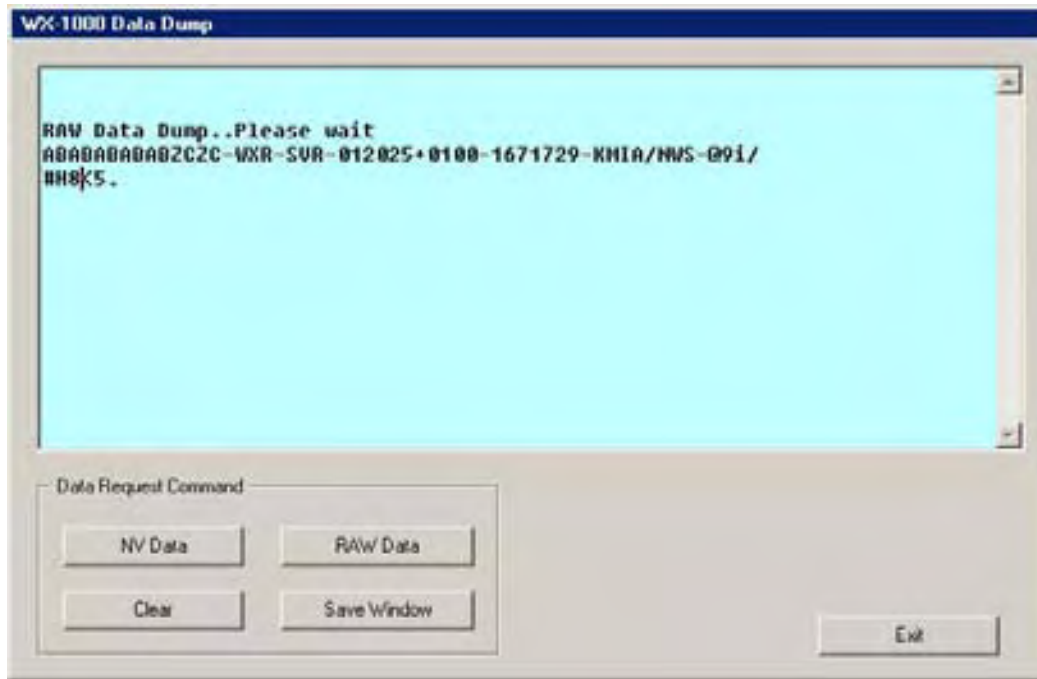

Figure 3-18

Event Codes

EAN	Emergency Action Notification	FLS	Flood Statement
EAT	Emergency Action Termination	HWA	High Wind Watch
NIC	National Information Center	HWW	Hurricane Watch
NPT	National Periodic Test	HUW	Hurricane Warning
RMT	Required Monthly Test	HLS	Hurricane Statement
RWT	Required Weekly Test	LFP	Local Public Forecast
ADR	Administrative Message	NPW	Wind Chill Advisory
ADM	System Test	SVA	Severe Thunderstorm Watch
BRT	Special Broadcast	SVR	Severe Thunderstorm Statement
BZW	Blizzard Warning	SPS	Special Weather Statement
CEM	Civil Emergency Message	SVW	Severe Thunderstorm Warning
DMO	Practice / Demo Warning	TOA	Tornado Watch
EVI	Evacuate Immediate	TOR	Tornado Warning (OLD)
FFA	Flash Flood Watch	TOS	Tornado Statement
FFW	Flash Flood Warning	TOW	Tornado Warning
FFS	Flash Flood Statement	WSA	Winter Storm Warning
FLA	Flood Watch	TSA	Tsunami Watch
FLW	Flood Warning	TSW	Tsunami Warning

Chapter 4 - Drawings

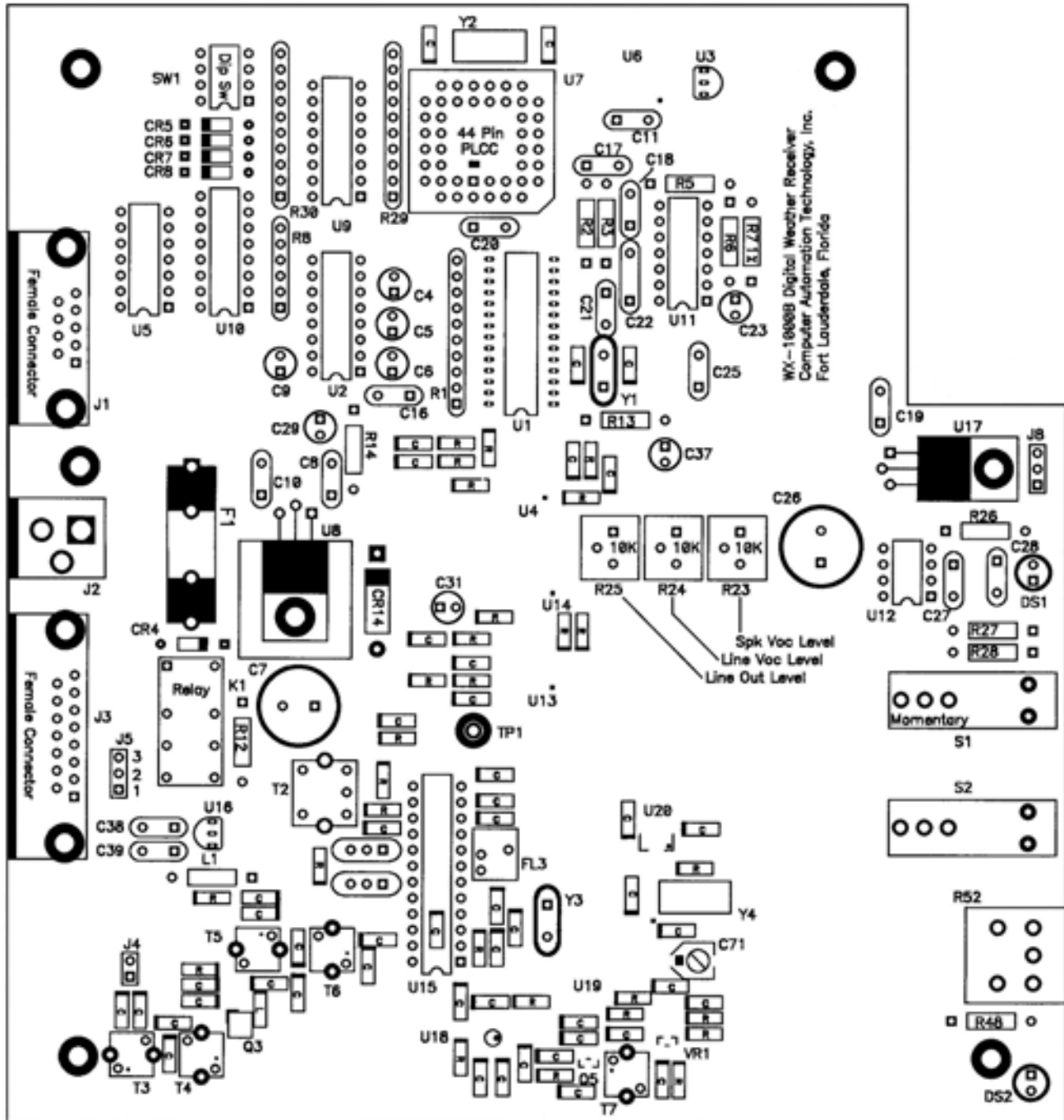
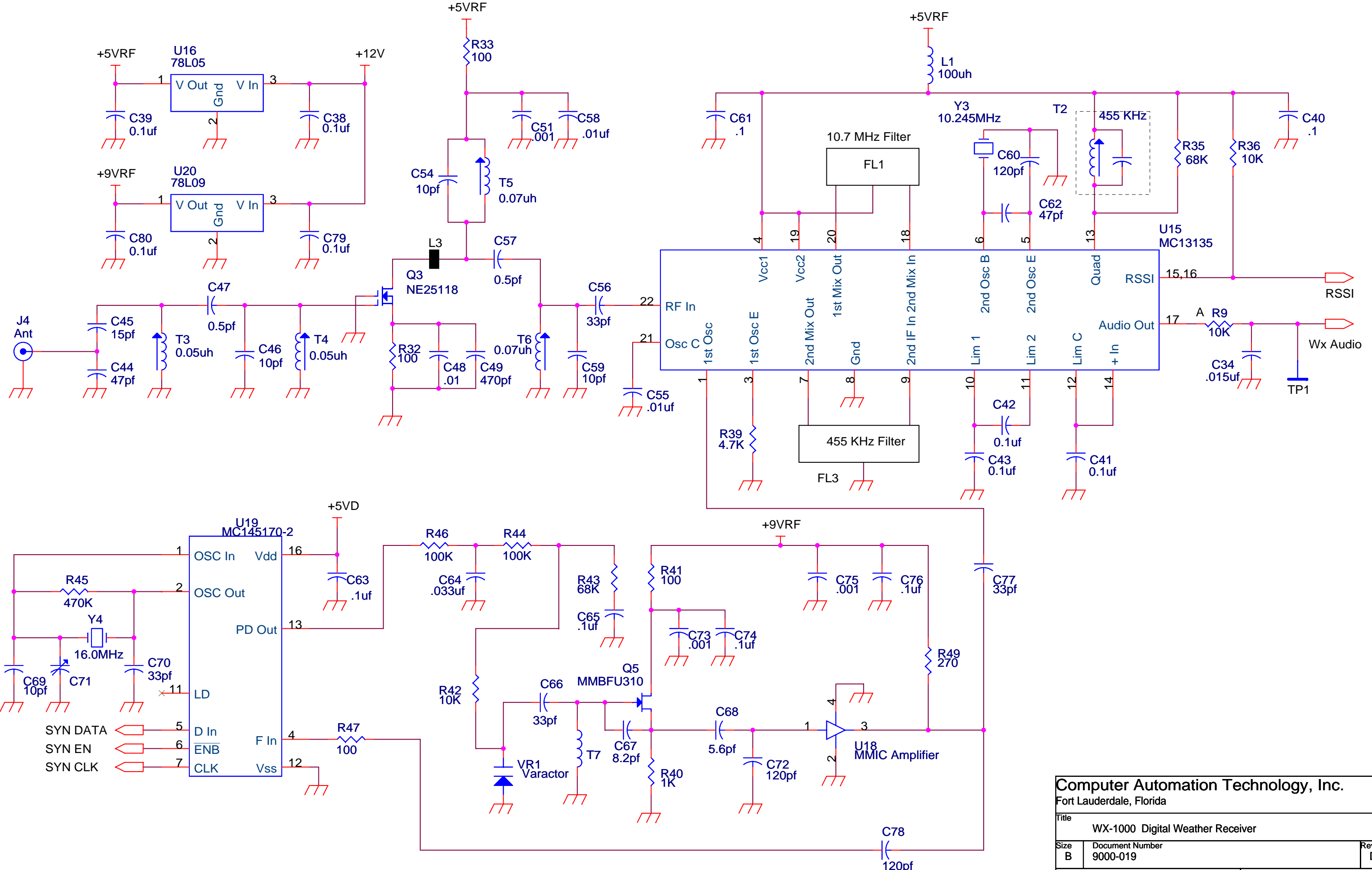
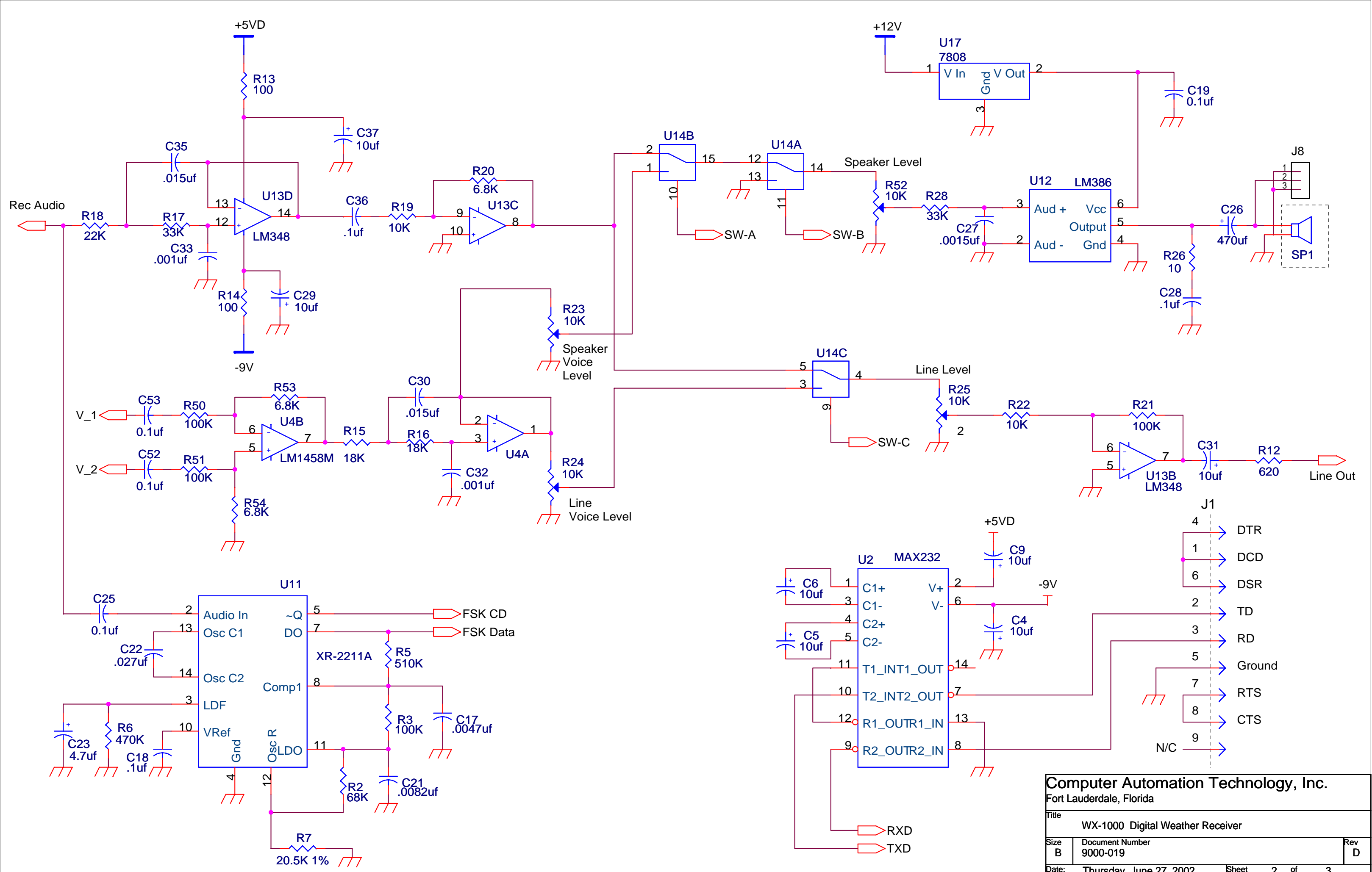
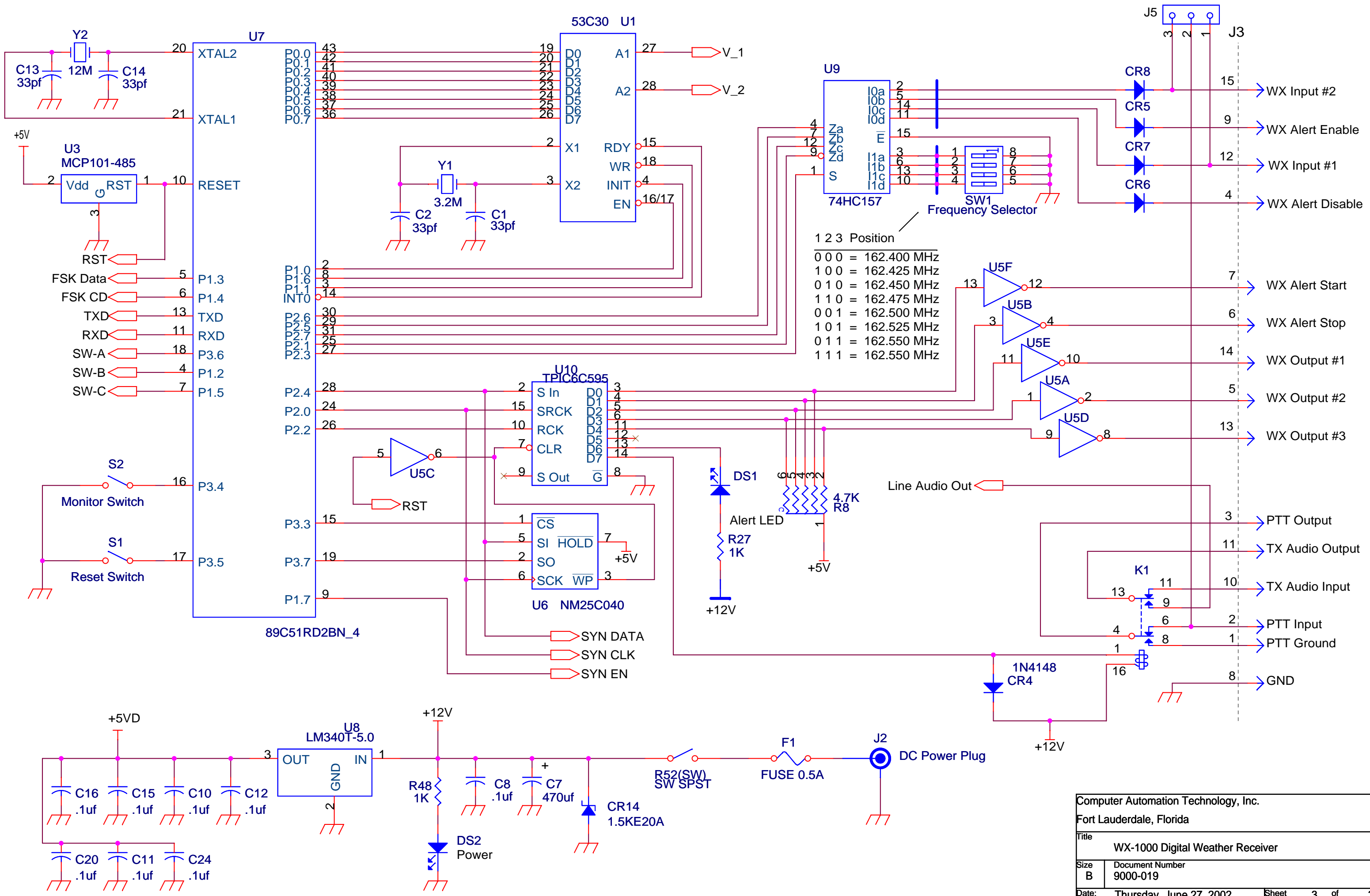

Figure 4-1







Computer Automation Technology, Inc.		
Fort Lauderdale, Florida		
Title WX-1000 Digital Weather Receiver		
Size B	Document Number 9000-019	Rev D
Date: Thursday, June 27, 2002	Sheet 3	of 3

Chapter 6 - Part List

1	Bead Inductor	P9810	L3
1	Cap Diode	6.8pf	VR1
1	Capacitor	.0015uf	C27
1	Capacitor	.0047uf	C17
1	Capacitor	.0082uf	C21
1	Capacitor	.027uf Film Cap	C22
11	Capacitor	.1uf 50V	C8, C10, C11, C16, C18, C19, C20, C25, C28, C38, C39
1	Capacitor	4.7uf 16V	C23
7	Capacitor	10uf 16V	C4, C5, C6, C9, C29, C31, C37
2	Capacitor	470uf 25V	C7, C26
6	Capacitor SM	.001uf	C32, C33, C51, C72, C73, C75
4	Capacitor SM	.01uf	C48, C55, C58, C63
3	Capacitor SM	.015uf	C30, C34, C35
1	Capacitor SM	.033uf	C64
14	Capacitor SM	.1uf	C36, C40, C41, C42, C43, C50, C52, C53, C61, C65, C74, C76, C79, C80
2	Capacitor SM	0.5pf	C47, C57
1	Capacitor SM	5.6pf	C68
1	Capacitor SM	8.2pf	C67
4	Capacitor SM	10pf	C46, C54, C59, C69
1	Capacitor SM	15pf	C45
1	Capacitor SM	22pf	C70
7	Capacitor SM	33pf	C1, C2, C13, C14, C56, C66, C77
2	Capacitor SM	47pf	C44, C62
2	Capacitor SM	120pf	C60, C78
1	Capacitor SM	470pf	C49
1	Capacitor Var	.7-20pf	C71
1	Connector	9D (F)	J1
1	Connector	15D (F)	J3
1	Connector	DC Power	J2
1	Crystal	3.27MHz	Y1
1	Crystal	10.245 MHz	Y3
1	Crystal	16MHz	Y4
5	Diode	1N4148	CR4, CR5, CR6, CR7, CR8
1	Diode	1.5KE20A	CR14
2	Filter	10.7 MHz	FL1, FL2
1	Filter	455 KHz	FL3
1	Fuse	0.5 Amp	F1
1	Header	1X2	J4
2	Header	1X3	J5, J8
2	I.C.	25C320	U6, Y2
1	I.C.	74HC14	U5
1	I.C.	74HC157	U9
1	I.C.	74HC4053	U14
1	I.C.	78L05	U16
1	I.C.	LM340-T5.0	U8
1	I.C.	LM340-T8	U17
1	I.C.	LM348M	U13
1	I.C.	LM386	U12
1	I.C.	LM1458M	U4
1	I.C.	MAR-1SM	U18

