

P.O. BOX 4155  
TORRANCE, CALIF. 90510  
(213) 540-1053

# **CONNECT SYSTEMS**

---

**PRIVATE PATCH<sup>™</sup>**  
**USER'S INSTRUCTION MANUAL**

Copyright (C) 1982 By Connect Systems  
Private Patch is a Trademark of Connect Systems

Rev A

CONGRATULATIONS! You now own the most technically advanced, feature packed, and capable autopatch/interconnect product available. Autopatch independence is now yours.

**Private Patch** is truly a complete function mobile to telephone interface. The possibilities for **Private Patch** are endless. The most obvious use is setting up **Private Patch** each day to fulfill specific communications requirements. For example, if you are to remain local, you will want to operate simplex for greater privacy and freedom. If you are going to drive out of simplex range, you will want to place **Private Patch** on your favorite repeater which covers your direction of travel. (Repeater should have at least 1-3 seconds hang time for satisfactory results.) Ringback and long distance inhibit switches should be set for your requirements. Another use for **Private Patch** is linking two mobiles together which are out of mutual radio range via telephone landline. Simply call your friend's phone number from your mobile. He receives and answers your call by using the ringback feature on his **Private Patch**. You now converse with the hook-up behaving as a repeater. One more possibility is having several **Private Patch** interconnects located in different cities but all on the same repeater, each having a different access code. You select the **Private Patch** which will give you a toll free call.

## ACCESS CODE

Subsets of a single five digit user programmable touch tone (DTMF) code provide all of the **Private Patch** functions. All five digits (ABCDE) provide the line connect. The first four of the same sequence provide the disconnect (ABCD). The first three provide the timer reset function (ABC). The factory installed code is 00221. Therefore until **Private Patch** is user reprogrammed, the connect code is 00221 (ABCDE). The disconnect code is 0022 (ABCD) and reset is 002 (ABC). The reset code also serves as the ringback connect code.

A DIP terminal strip may be found between integrated circuits U-37 and U-11 on the printed circuit card. This is where the access code is programmed. (The DIP terminal strip may be removed from its socket for easy programming.) Your code can be any combination of 0, \*, 2, 1, which are the four available decoded digits. The code sequence goes in the order ABCDE. Therefore, if you connect the A to 0, B to 0, C to 2, D to 2, and E to 1 the code is 00221, as factory supplied. See Figure 1 for clarification. The three examples in Figure 1 should make clear the programming procedure.

When selecting your personalized access code, do not make the middle digit (C) 0 or 1. If 0 or 1 is used in the C position, ringback will not function properly. The following code types should not be used: \*\*1\*\*, 00000, 22122, etc., while \*\*\*\*\*, 00200, 22\*22 would work satisfactorily.

Dial your commands no slower than 1 digit per second (very slow) nor faster than about 6 digits per second (very fast). Send commands about the same speed you would dial a phone number.

### CW ID PROM

If you purchased your **Private Patch** factory direct, your CW ID PROM is already installed. If you purchased it through a dealer, a jumper wire is installed in the CW ID PROM socket, U19 near the power transformer. The jumper will enable you to use **Private Patch** until you receive your CW ID PROM chip. Until you install your ID PROM, the ID will consist of a string of dits.

Send proof of purchase (a copy of your receipt will do) along with the call you wish programmed into the PROM to:

**Connect Systems  
P.O. Box 4155  
Torrance, CA 90510**

Within 24 hours we will ship your ID PROM postpaid to you. No charge.

When you receive the PROM chip, unplug your **Private Patch**, take off the cover, and remove the jumper wire installed into the IC DIP socket U-19. Carefully install the PROM into socket U-19. Be sure the cut out end or dot end of the IC is toward the rear of the unit.

Should you change call sign, we will program a new PROM for you for a nominal fee of \$15.00.

Note: In commercial service the PROM will be programmed with a series of dashes.

## OPERATION

Learning to use the **Private Patch** commands and modes will seem a little involved at first. But soon you will use it as naturally as driving your car.

**THE COMMANDS:** ABCDE will refer to your private access code, while 00221 will refer to the factory installed access code. To make a call, you will need a line connect. Send 00221 (ABCDE). Should you misdial your number, send the connect code again. No need to send the disconnect (off) command first. When through, send the disconnect (off) command 0022 (ABCD). Your autopatch will automatically "time out" (causing a disconnect) after six minutes. (Time out disconnect may be changed to three minutes by connecting the board strap from the "6" position to the "3" position at a location on the circuit board between integrated circuits U31 and U10, labelled "TIMER". If delivered into commercial service, the timer will be strapped to three minutes.) Prior to "time out" disconnect, CW ID will warn four separate times that "time out" is imminent. You may send the timer reset code to gain another timer period. Send 002 (ABC) to reset. You can send the reset code as often as you like. The reset code serves also for answering incoming calls if Ringback mode is selected. Ringback will be covered in detail later on.

**TO MAKE A CALL:** Send the connect code 00221 (ABCDE). **Private Patch** will respond with your station call sign in CW followed by a dialtone. CW ID and the dialtone may overlap somewhat if your call sign is lengthy. After two seconds the dialtone will disappear. **Private Patch** has gone into the receiving mode to pass your dialing instructions on to the phone line. There are two ways to dial your number:

- 1) If the Long Distance/ Restrict switch is in the Long Distance position, there are no dialing restrictions. After the dialtone goes off, start your dialing within 3 seconds. Dial the complete number in one go.

- 2) If you want Long Distance Dialing Restrict, place the switch in the Restrict position. Now calls beginning with 0 or 1 cannot be made. When in the Long Distance Restrict mode, the dialing procedure is a little different. After the dial tone drops, dial only the first digit of the number you wish to call. Now listen for a tone prompt which gives you clearance to complete the dialing of remaining digits. Be sure the prompt tone is completed before you finish your dialing.

When your party answers be sure to explain to them that you must take turns talking. Often, "first timers" do not understand this and confusion results. When you are finished, wait for your party to hang up before sending the disconnect command 0022 (ABCD). The act of hanging up will generate much audio on the phone line. **Private Patch** will assume this is your party speaking and come on the air for about one half second. If you are sending a command when this occurs, **Private Patch** may miss some of your digits and not respond to your command. Therefore, it is best to wait for your party to hang up before transmitting commands.

Commands can only be sent when the interconnect is receiving. Simplex by definition means one way at a time. You must wait until the interconnect stops transmitting before a new command may be issued.

For example:

1. You call a number and there is no answer. You wish to disconnect. Send the disconnect sequence 0022 (ABCD) between rings while the interconnect is "listening".

2. You have successfully completed a call and talked five minutes. Suddenly you hear CW ID timeout warnings on top of your party. You now wish to send the reset sequence 002 (ABC) for additional talk time. But you must wait until your party finishes talking and **Private Patch** returns to the "listening" state before you can send the timer reset sequence.

**ACTIVITY TIMER:** Suppose the number you had called were busy. **Private Patch** would assume the busy signal was speech and transmit continuously so that you could hear the party you had called. Obviously control would be lost. But the **Private Patch** activity timer logic assures positive control. If the Autopatch transmits continuously for twenty seconds (this seldom happens in the course of conversation) the activity timer causes a three second interrupt "window". Quickly, during this three-second window, you send control commands. Connect 00221 (ABCDE) to redial, or disconnect 0022 (ABCD) if finished. If the long distance restrict switch happens to be in the Restrict position, a "short-cut" disconnect code is available. Merely send a 1 or a 0. This will cause disconnect just as if attempting to dial long distance. This only works during activity interrupt windows, and only if the switch is in the Restrict position.

An alternate option to "interrupt control" windows is "Talk Off Disconnect" (TOD). A jumper wire may be connected between the pads labelled "TOD" on the printed circuit board. (Near integrated circuit U-32). Now instead of obtaining a control window after twenty seconds, automatic disconnect will occur instead. This is useful for busy signals, but could be a problem when speaking with someone who is a bit longwinded. Develop a communications posture that encourages interactive conversation. By talking back and forth say 2-15 seconds each, the activity timer will be constantly reset. (Note: If delivered into commercial service, the "TOD" strap will be in place.)

**TO USE SIMPLEX:** Set your base station transceiver and your mobile to the same simplex frequency. Be sure transmitter offset frequency switches are "off". Set the Autopatch transceiver squelch control to a point well beyond the squelched (quiet) side of threshold. You will not want the control fully "tight" in simplex because some range may be lost. **Private Patch** is super easy to use in simplex. You should master the technique of using your autopatch on simplex frequencies before attempting repeater operation. Install good quality antennas as high as possible and you will be surprised how good your simplex range can be. But often simplex range is not sufficient.

**TO USE THROUGH REPEATERS:** Set the transmit and receive frequencies on your autopatch transceiver just as though you were going to talk through the selected repeater. Set your mobile or handheld likewise. Set the squelch control on the autopatch transceiver fully tight. (Be sure you have selected a repeater which has at least 1-3 seconds hang time. The more hang time the better). Operation through the repeater proceeds identical to simplex. However, occasionally CW ID originating in the repeater may cause temporary directionality confusion for the autopatch, for the duration of the CW ID. Perhaps five seconds every three minutes or so. Not really a problem.

As usual, when operating through repeaters, squelch tails are different than when operating simplex. In simplex, when the autopatch stops transmitting, the squelch you hear closing is your own. But when through a repeater, the squelch you hear is at the repeater. You do not hear your own squelch close until the repeater drops out. The point is, you cannot control **Private Patch** unless it is listening. **Private Patch** is listening immediately after any squelch tail even though the repeater is still transmitting. Suppose you dial a number, and there is no answer. You wish to make another call or disconnect. **Private Patch** will transmit during each ring and for half a second afterward. After you hear the squelch tail but before the next ring, send the command (connect or disconnect) you desire. **Private Patch** will respond immediately to your commands.

**RINGBACK:** Ringback allows you to receive incoming calls. This feature may be turned on and off from the front panel. Ringback is not permitted in some radio services and must be left off. When turned on, (ringback position) calls coming into your autopatch phone line will cause **Private Patch** to come on the air and transmit CW ID. Only one CW ID page cycle will occur. If the channel is busy, or has had activity within the last 15 seconds, **Private Patch** channel monitor logic will not allow the CW ID page to be transmitted. This feature will be appreciated by your co-channel users as inadvertant interference is avoided. Shortly after the CW ID, the autopatch will stop transmitting. Now send your ringback connect code 002 (ABC) to answer. You may now respond to the caller. If your party has hung up before you answer, you will get a dial tone upon answering. Wait for a control interrupt window, and send a disconnect command (ABCD), or a 0 or 1 if in dialing restrict.

After answering your call with a ringback connect code 002 (ABC), the call proceeds just as though you placed the call yourself. The CW ID timer warning and time out timer features are functional. You may send the reset code 002 (ABC) for additional talk time. When you are finished you must send a disconnect command 0022 (ABCD) to terminate the call (hang-up).

**Note:** If you talk into your microphone immediately after sending a reset command sequence (ABC) there is a slight chance that **Private Patch** may disconnect. This applies to timer resetting as well as ringback answering. The solution is to send your reset code sequence but delay your talking for about 2 seconds. The command sequence register is erased one second after the last touch tone has been sent. But for this one second after sending a reset code **Private Patch** is somewhat vulnerable to voice falsing. The combination of true synchronous sequential logic and automatic register erase make falsing a practical impossibility the remainder of the time.

**COVERAGE TEST:** Suppose you really don't want to make a call, but are curious about how well you can hear the autopatch from your present location. Send a connect command 00221 (ABCDE). **Private Patch** will respond as if you were going to call someone. But, instead of dialing a number when the dialtone drops, send a disconnect 0022 (ABCD). Or merely a 0 or 1 will do if the Long Distance Restrict feature is on.



## THE CONNECTIONS

One of the many benefits of the **Private Patch** design is the simplicity of interface to your transceiver. No connections to the inside of your transceiver are necessary. You will need to make up three shielded cables which go between **Private Patch** and your transceiver. These shielded cables will have RCA phono plugs on the **Private Patch** end and a plug which mates to your accessory socket or microphone and speaker jacks on the transceiver end. Many transceivers have the PTT, microphone and speaker connections in the accessory socket. This is the preferable connection point, since you can leave your microphone connected to the transceiver. This will allow easier use of your transceiver as a base station. Be sure to turn **Private Patch** off when using your base transceiver locally. The three phono plugs and a modular phone cord are provided. Plug the modular phone cord into the modular jack in the rear of **Private Patch**. Connect the other end either to your private phone system or to a telephone coupler. Figure 2 makes the connections clear. Be careful not to create solder shorts or heat induced shielded cable shorts.

## ADJUSTMENTS

It will be necessary to remove the cover to make three internal adjustments. Before removing the cover, be sure to unplug the power cord. Make all the necessary connections to your transceiver and the phone line. Plug in the AC cord and turn on the power switch. **WARNING**, there are dangerous electrical voltages on the transformer end of the printed circuit board. If not qualified, obtain professional help when working inside the unit.

The following set-up procedure assumes that the touch tones are operating properly in your mobile, handheld or what have you. The frequencies must be correct, and touch tone deviation level of your transmitter should be set to about 4 KHZ.

The controls are clearly identified with silk screening on the printed circuit board. Due to a fully digital timing and logic design, there are no timing adjustments in this product. This greatly eases the burden of set-up. The potentiometers and their function are as follows:

P-1 touchtone injection level	P-5 697HZ touch tone FREQ
P-2 Receiver noise gate	P-6 941HZ touch tone FREQ
P-3 Phone line VOX sensitivity	P-7 1209HZ touch tone FREQ
P-4 Phone line to transmitter Audio level	P-8 1336HZ touch tone FREQ

The audio level transferred from the autopatch transceiver to the phone line is adjusted with the volume control on the transceiver front panel. With the exception of P-4 and the transceiver volume control adjustment, the other pot settings should be "close" as delivered from the factory. As a first cut, set the volume control on your base transceiver to about half rotation. P-1 touch tone injection level should also be at about half rotation. Set-up for simplex operation as previously described. Send a 0, \*, 2 or 1 from your touch tone keyboard. The touch tone decode LED D-12 (near U-3) should light whenever any of these four digits are pressed. If it does not light, turn up the volume control on your autopatch transceiver until it does light when you press one of the four digits. D-12 is provided for your convenience in setting up the touch tone decoder level (P-1). If all four digits illuminate the LED D-12, you may now send a connect command 00221 (ABCDE). The autopatch should respond immediately, as described earlier.

Make your first call to a friend and get the audio levels set up. Adjust the base autopatch transceiver volume as necessary until your level sounds correct at the telephone end. Adjust P-4 on the circuit card until the audio level sounds good in the mobile coming from the phone line. Once that is established, set up the touch tone decoder level. Transmit a 0, \*, 2 or 1. D-12 should light. Adjust P-1 CCW until D-12 goes out. Rotate P-1 CW and see if it goes out on the high end. It probably will not. Set P-1 midway between these two extremes. The decoder is very forgiving, making P-1 a very non-critical adjustment. P-2 the receiver noise gate is normally set at full CW rotation. Full CW is always correct for simplex and nice loud repeaters. But if you are trying to operate through a repeater which is so distant as to be received noisy, you may need to reduce the setting of P-2. The symptom is that you will not be able to hear the party on the phone. 99% of users will leave P-2 fully CW.

Note: If your transceiver has a squelch circuit which is a bit noisy when squelched, you may need to reduce the setting of P-2 slightly. Reduce only to a point where the autopatch functions properly.

Our audio and digitally processed VOX represents as fine a VOX as has ever been designed. But the VOX level control P-3 will require a little experimentation over a period of many calls for totally optimum results. Half rotation is a very good starting point. If the sensitivity is too low, the VOX will not attack well on weak voices. (By the way, you should instruct the person you are speaking with to talk directly into the handset microphone). If the sensitivity is too high (CW) background noises such as TV sets playing may either trip or hold the VOX. A compromise must be achieved. Once set correctly, the VOX will perform splendidly. Incidentally, a VOX is the only practical way an autopatch can function through a repeater. It also saves you from having to listen to sampling kerchunks, saves you from making connections to the squelch circuits in your transceiver, greatly relaxes T/R speed requirements in your transceiver etc.

P-5 through P-8 are touch tone frequency alignment adjustments. These have been set at the factory with a counter. We have used 1% metal film resistors and mylar capacitor frequency determining components. As a result, these circuits should never require re-adjustment. If unsatisfactory touch tone decoder performance ever occurs, check the levels previously mentioned as well as the encoder performance. To align the decoder properly you will need a counter.

ADJ P-5 until U4-5 reads 690 HZ  
ADJ P-6 until U5-5 reads 950 HZ  
ADJ P-7 until U6-5 reads 1209 HZ  
ADJ P-8 until U7-5 reads 1336 HZ

Even though all eight internal adjustments were described, note that you only had to set-up three adjustments inside your **Private Patch**. P-1, P-3, and P-4.

## NOTES

1. Our touch tone decoder is much more forgiving than phone company decoders. Therefore inadequate levels, etc., from your mobile may function your **Private Patch**, but not dial the line. Be sure your equipment is on frequency and that your touch tones are causing 4 KHZ deviation on your base transceiver.

2. A slow or sluggish squelch in your mobile and/or handheld may cause you to miss the first portion of the first word when your party responds to you. Adjust your mobile and/or hand-held squelch to "just squelched". This will speed up the squelch. In extreme cases you may want to change the value of your squelch delay capacitor for quicker response. When using **Private Patch** through a repeater, this is not a problem because the repeater opens your squelch before your party even replies. The **Private Patch** VOX system detects audio and keys your PTT in 10-20 milliseconds.

3. A transceiver without any T/R relays is preferable because it can change from receive to transmit more rapidly. But satisfactory results should be obtained from most transceivers regardless.

## WARRANTY

We guarantee **Private Patch** to be free from defects in material and workmanship for one year from purchase. Tampering, misuse or modification shall void this agreement.

The quality of components used in **Private Patch** are excellent. It should give many years of trouble-free service. Should it fail, we shall repair it for a very nominal charge, and return it to you within 1 day if possible.

We will not repair units which have been "modified".

This warranty does not cover damage caused by any acts of God.

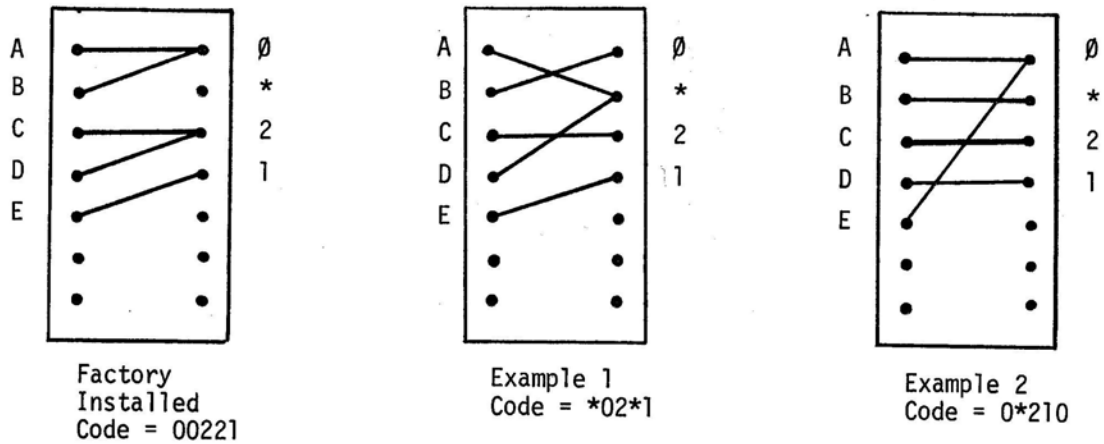

Figure 1  
ACCESS CODE PROGRAMMING

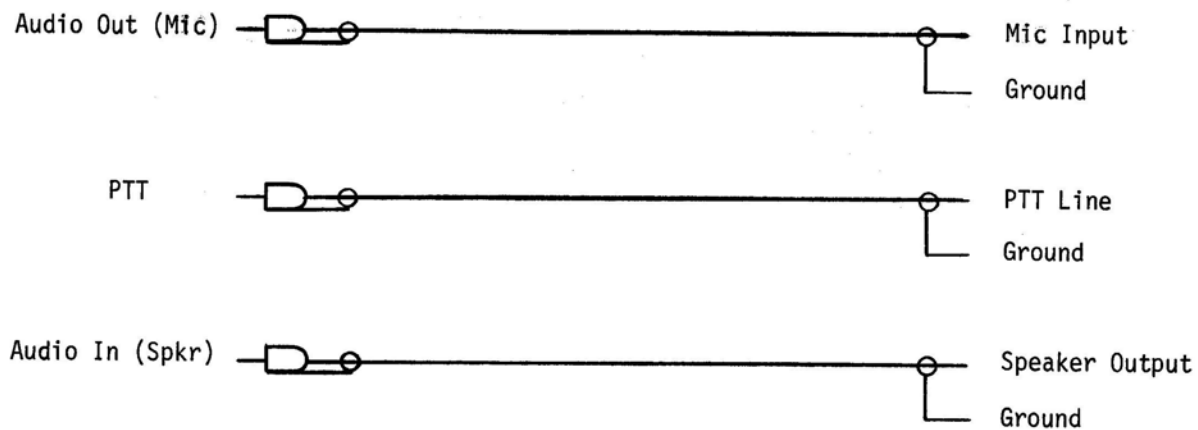
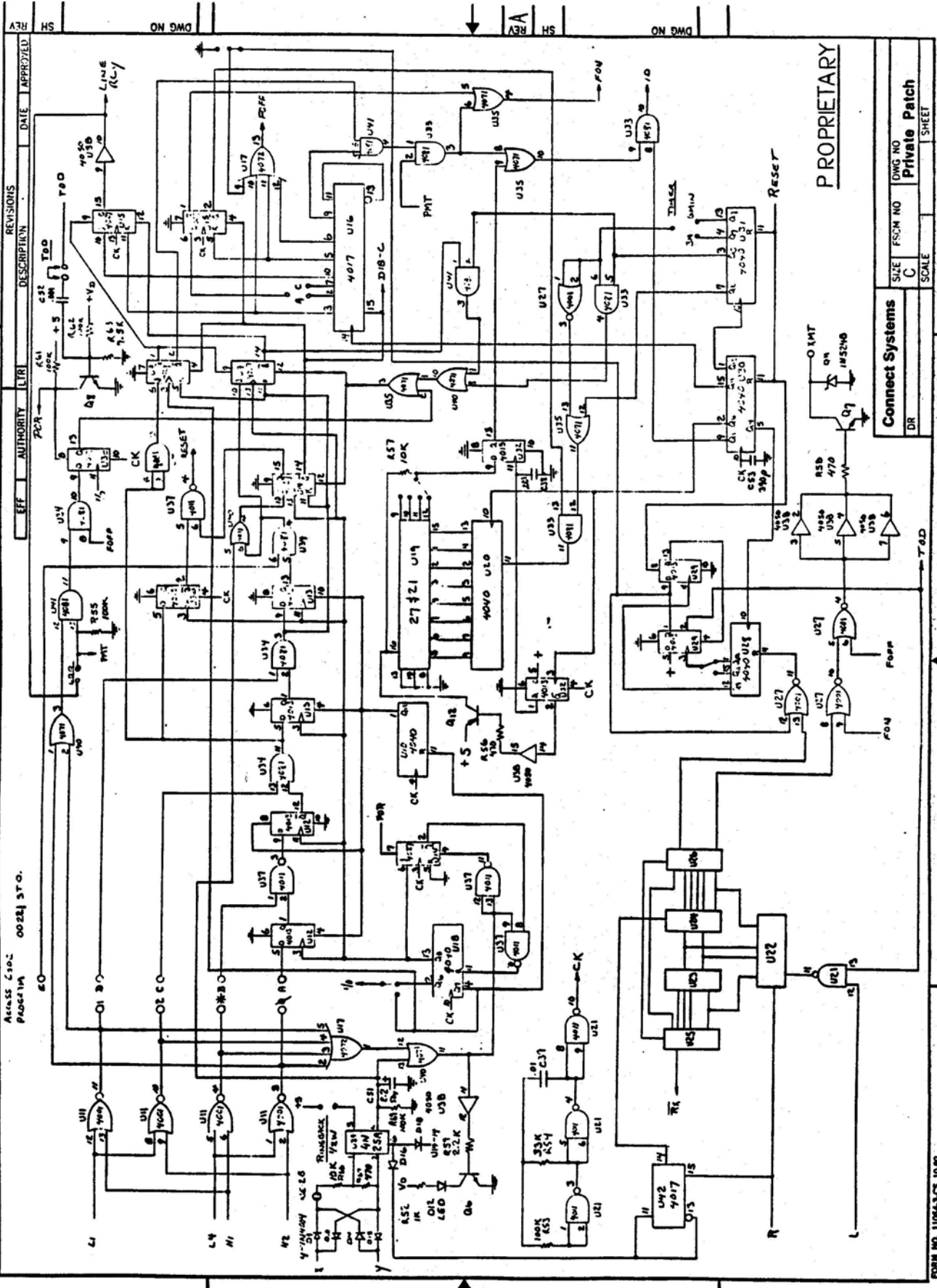
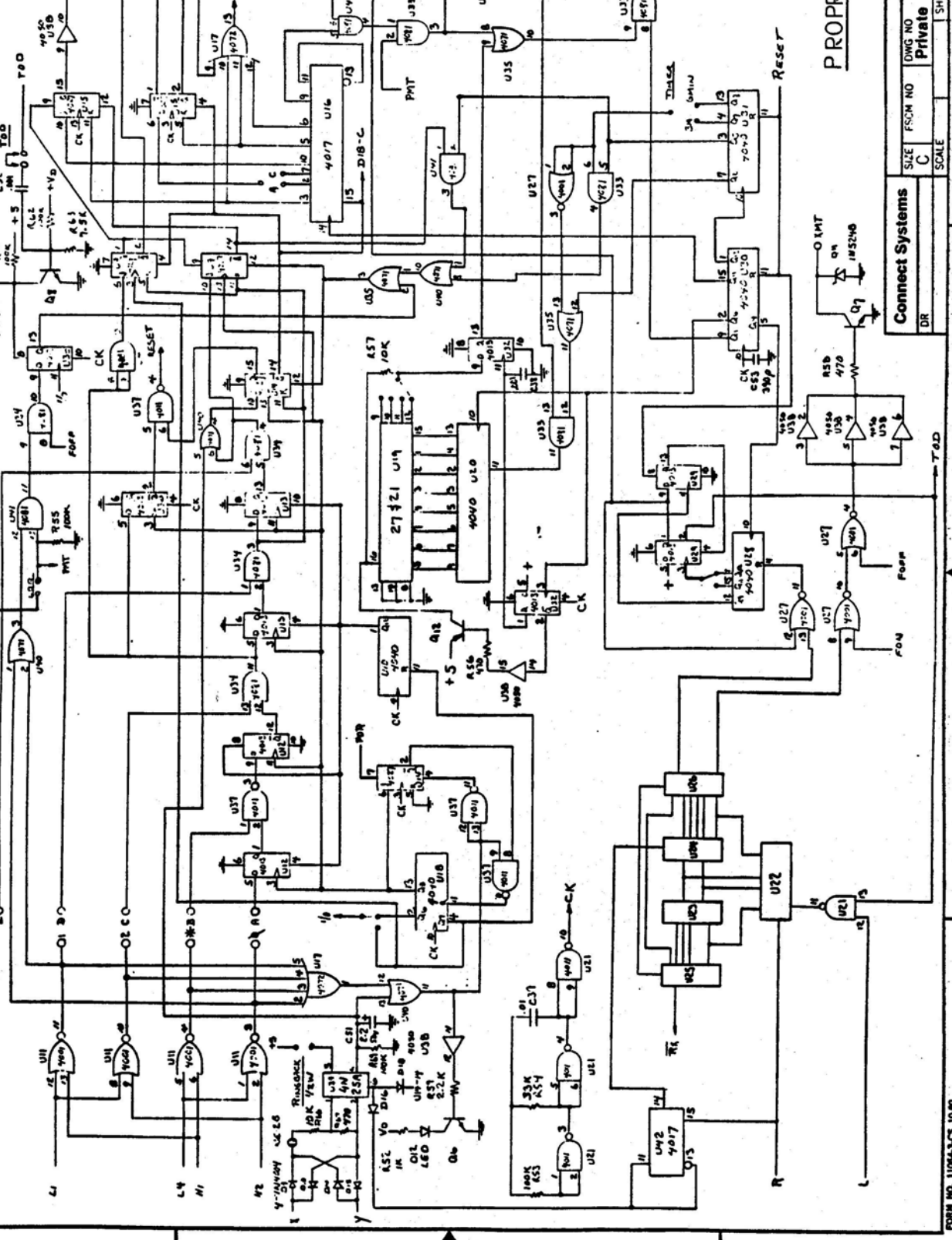

Figure 2  
PRIVATE PATCH/TRANSCIEVER  
INTERCONNECTIONS



Access C502  
 PAB0214 00221 STO.

REV	SH	DWG NO	REVISIONS	DATE	APPROVED



EFF	AUTHORITY	LTR	DESCRIPTION	DATE	APPROVED

DR	SCALE	FSCM NO	DWG NO	Private Patch	SHEET

PROPRIETARY

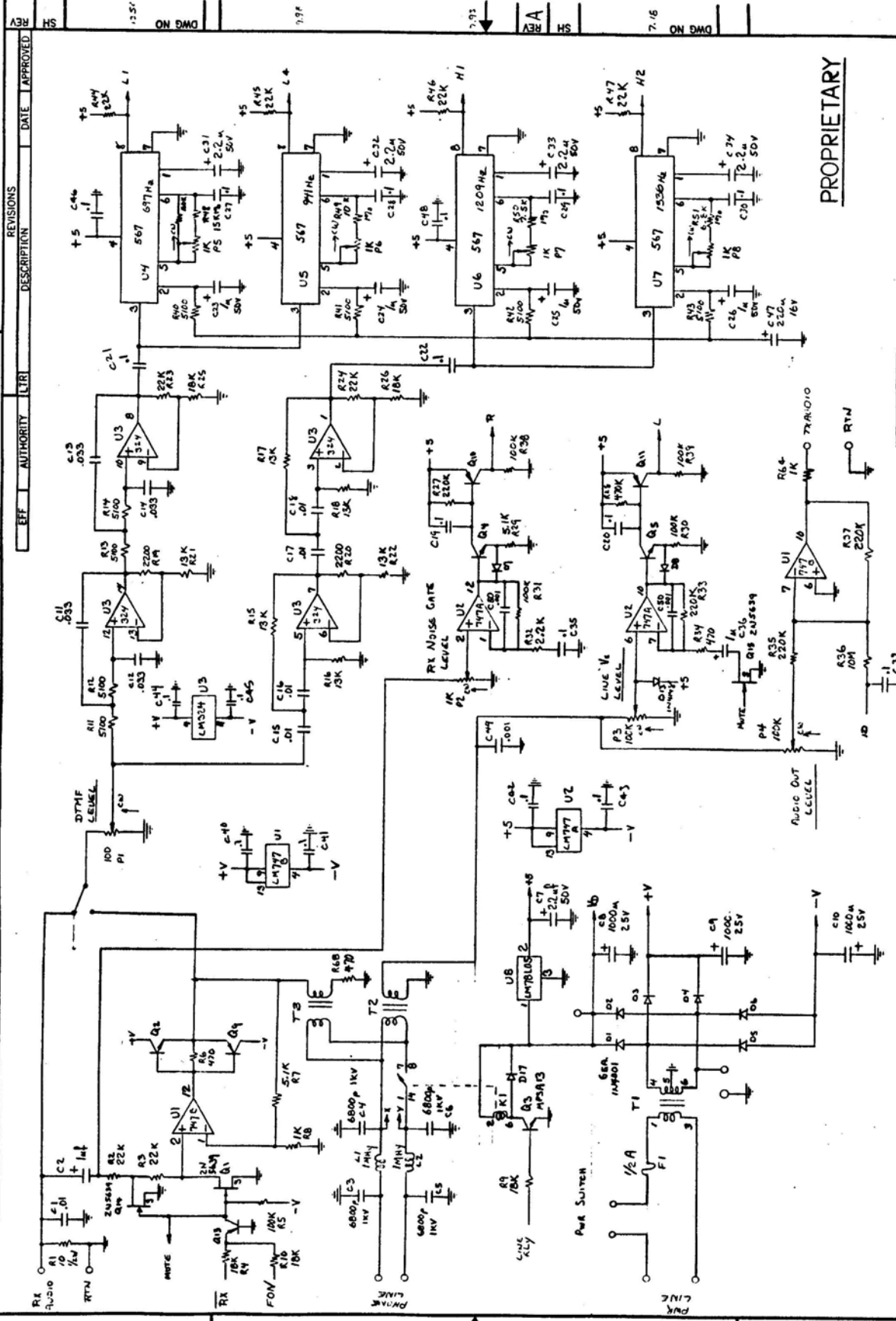

REVISIONS		DATE	APPROVED

EFF	AUTHORITY	LT/RI	DESCRIPTION

DR	Connect Systems	SIZE	FSCM NO	DWG NO	Private Patch
		C			
		SCALE			SHEET

PROPRIETARY

REC HS 12.51 ON DWG 7.97 7.93 RE A HS 7.16 ON DWG