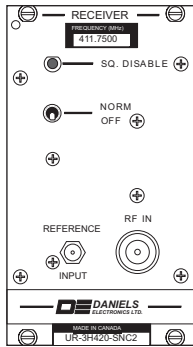

TN262 UR-3H400-S UHF Enhanced Receiver

The UR-3H400-S receiver is a high performance synthesized FM receiver capable of operating in 12.5 KHz (narrowband) or 25 KHz (wideband) channels. The UR-3H400-S receiver operates in one of two frequency bands: 406 to 430 MHz or 450 to 470 MHz. A modular design allows each of the receiver's three internal modules, 21.4 MHz FM IF/Audio Main Board, FE3H Enhanced Front End, and OS-3H400 Synthesizer, to be individually assembled and tested. This facilitates construction, tuning and maintenance as well as troubleshooting procedures. The synthesizer module can be programmed to have up to 16 channels exclusive to one frequency band.

Specifications

Frequency Bands	406 - 430 MHz / 450 - 470 MHz
Channel Spacing	12.5 KHz or 25 KHz
Receiver Switching Range	± 2 MHz
Reference Sensitivity (12 dB SINAD)	<-116 dBm (.350 µV)
Adjacent Channel Rejection (Selectivity)	> 75 dB (narrowband) / > 80 dB (wideband)
Spurious Response Rejection	> 95 dB
Intermodulation Rejection	> 85 dB
Hum & Noise Ratio (20 KHz Low Pass Filter)	> 48 dB (narrowband) / > 55 dB (wideband)
L.O. Frequency Stability	± 1.0 ppm (-30 °C to +60 °C) (-40 °C to +60 °C optional)
Modulation Type	11K0F3E (FM) or 16K0F3E (FM)
Audio Distortion	< 2.0% @ 25 °C (< 6.0% @ -40 °C to +60 °C)
Receiver Attack Time	< 10 ms
Receiver Closing Time	< 10 ms
Squelch Threshold / Hysteresis	-123 to -105 dBm, adjustable from 2 dB to 20 dB
Audio Output (600 Ω Balanced or Unbalanced)	+3.0 dBm De-emphasis/Flat
Input Impedance	50 Ω (Type N Connector)
Operating Temperature	-30 °C to +60 °C (-40 °C to +60 °C optional)
Operating Current (Squelched)	< 400 mA

Models Available

UR-3H420-SWC200	Enhanced Synthesized, 25 KHz Bandwidth, 406 - 430 MHz
UR-3H420-SNC200	Enhanced Synthesized, 12.5 KHz Bandwidth, 406 - 430 MHz
UR-3H460-SWC200	Enhanced Synthesized, 25 KHz Bandwidth, 450 - 470 MHz
UR-3H460-SNC200	Enhanced Synthesized, 12.5 KHz Bandwidth, 450 - 470 MHz

Receiver Operating Frequency

The receiver is initially aligned at the factory for the frequency stamped on the 'Factory Set Operating Frequency' label on the front panel. For a small frequency change, no re-alignment of the receiver may be required. If the frequency change is greater than ±2 MHz from the frequency at which the last complete receiver alignment was performed, the **front end** will need to be realigned. To align and / or adjust the receiver the outer cover needs to be removed, the receiver needs to be plugged into the subrack via a cable and / or extender card and power must be applied to the system.

TN262 UR-3H400-S UHF Enhanced Receiver

Receiver Alignment Procedures

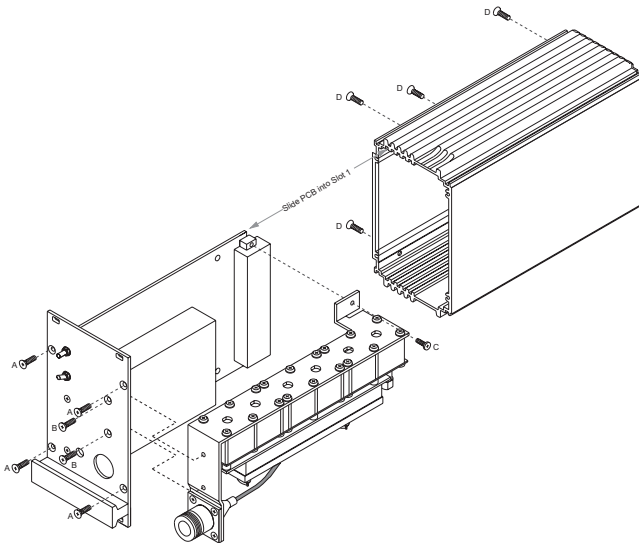

Remove the four front panel screws (A) and four side panel screws (D) to slide the receiver outer cover off and expose the IF / Audio Main Board Local Oscillator and Front End Assemblies. Remove the two front panel screws (B) and internal screw (C) to remove the Front End for easier access to the Local Oscillator.

Synthesizer Alignment:

No synthesizer alignment is required.

Squelch Adjustments:

Receiver squelch action is factory set to establish a squelch hysteresis window of 6 dB centred about the point of receiver 12 dB SINAD sensitivity. eg. If the receiver sensitivity point is -116 dBm the receiver should be set to unsquelch at -113 dBm and squelch at -119 dBm. Adjustment to the squelch circuitry should be the last receiver alignment step performed. Rotate the squelch hysteresis adjust potentiometer (R115) fully counter clockwise. Rotate the squelch threshold potentiometer (R88) fully clockwise. Inject a standard signal at the desired unsquelch level. Slowly adjust the squelch threshold potentiometer (R88) counter clockwise until the receiver unsquelches. Advance R115 (hysteresis) clockwise until sufficient hysteresis prevents any oscillating COR action at the squelch threshold point. Cycle the RF source off and on while adjusting R88 (threshold) until squelch triggering occurs at the desired signal level. Adjust R115 (hysteresis) clockwise to increase the squelch hysteresis window. Slowly lower the RF source signal level and monitor the point at which the receiver squelches. Increase or decrease R115 (hysteresis) to achieve the desired hysteresis window.

Front End Alignment:

Alignment for the Enhanced Front End consists of tuning the five pole band pass filter only. There are two methods of tuning the Enhanced Front End. The preferred method of tuning the Enhanced Front End is to use a Spectrum Analyzer with a Tracking Generator. Ensure that the +9.5 Vdc supply is connected to the Front End (red wire). Connect the Tracking Generator output to the Front End's RF input. The Tracking Generator should have an output level of -10 dBm and the Spectrum Analyzer should have a frequency span of at least 10 MHz. Connect the Spectrum Analyzer input to the Front End's IF output. Adjust C20 through C24 for a uniformly flat response centered at the desired RF frequency. The alternate method of tuning the Enhanced Front End is to monitor receiver SINAD. Inject the desired RF signal to the RF input connector at a level of -116 dBm and adjust C20 through C24 for best receiver SINAD (>-116 dBm).

Note: For complete alignment procedures, refer to the instruction manual. These notes are for reference only.

43 Erie Street
Victoria, B.C.
Canada V8V 1P8

Toll Free Canada & U.S.A.
Phone: 1-800-664-4066
Fax: 1-877-750-0004

International
Phone: 250-382-8268
Fax: 250-382-6139

Internet
e-mail: sales@danelec.com
web: www.danelec.com