

Broad Band Gain Antenna DB224



PRODUCT DESCRIPTION

The DB224 is a heavy duty, light weight, high gain antenna. It is suitable for mounting to the top or on the side of a tower. Clamps for top mounting are supplied with the antenna; an additional side mount kit (DB5001) must be ordered for side mounting.

ELECTRICAL DESIGN

The antenna is a four stack collinear array designed to provide high gain, broad bandwidth and minimum pattern distortion. A binary cable harness is used to ensure equal in-phase power distribution to all radiating elements.

OPTIONAL RADIATION PATTERN

The DB224 can be used as an omnidirectional antenna having a gain of 6 dBd or as an elliptical pattern antenna having a maximum gain of 9 dBd. An omni pattern is achieved when the four dipole elements are spaced evenly, every 90° around the mast (Figures 1 and 2). An elliptical pattern is obtained when all four dipole elements are positioned in a line (collinear) along the mast. When top mounted, the omni and elliptical models provide radiation patterns as shown in Figure 3. When side mounted, the two models provide significantly different radiation patterns (see SIDE MOUNTING and Figure 4). The antenna can be changed in the field from one pattern to the other using ordinary hand tools.

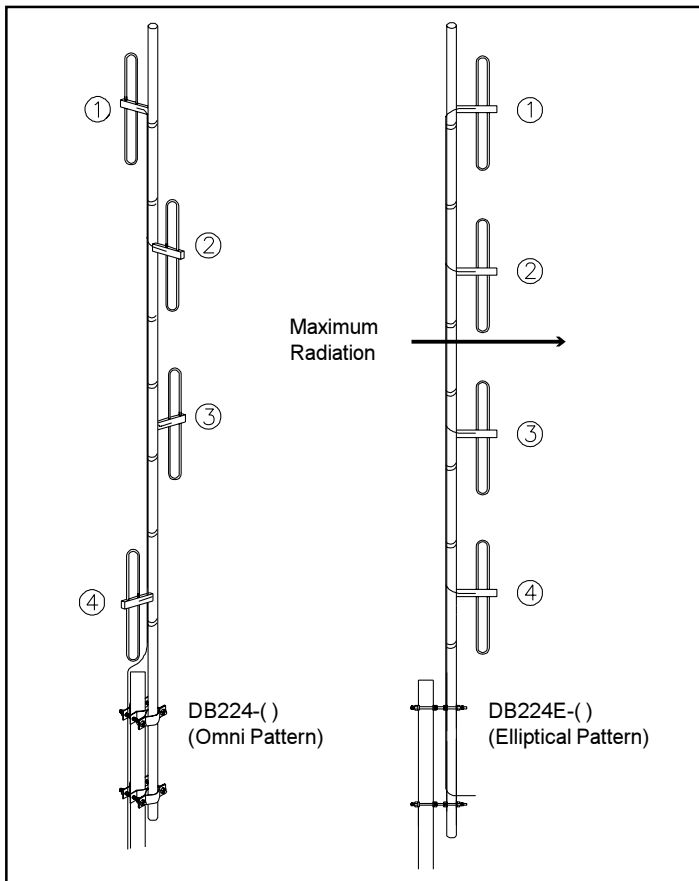

Figure 1. Dipole Alignment

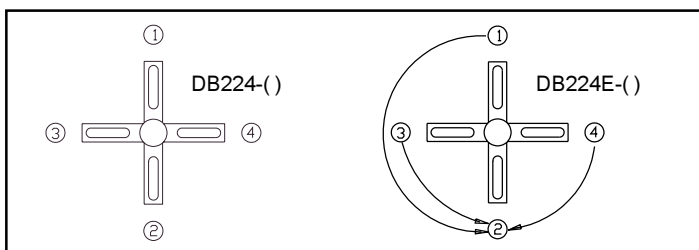

Figure 2. Top View Dipole Alignment

(continued on page 2)

NOTICE

The installation, maintenance, or removal of an antenna requires qualified, experienced personnel. Andrew installation instructions are written for such installation personnel. Antenna systems should be inspected once a year by qualified personnel to verify proper installation, maintenance, and condition of equipment.

Andrew disclaims any liability or responsibility for the results of improper or unsafe installation practices.

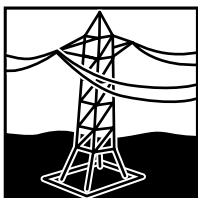

Do not install near power lines. Power lines, telephone lines, and guy wires look the same. Assume any wire or line can electrocute you.



Do not install on a wet or windy day or when lightning or thunder is in the area. Do not use metal ladder.



Wear shoes with rubber soles and heels. Wear protective clothing including a long-sleeved shirt and rubber gloves.

TWO PIECE MAST

For ease of handling and to facilitate shipment, the mast is made in two sections. Assembly of the sections is quite simple and requires only the use of ordinary hand tools. The unique center splice assures proper alignment.

LIGHTNING PROTECTION

The aluminum mast with a pointed cap provides a positive low resistance discharge path to the tower or ground system, thus affording superior protection against lightning damage. All radiators are operated at DC ground to provide further protection against lightning and static buildup.

DUAL ANTENNAS

Dual antenna models are available which include two independent antennas on a common mast, each with a separate feed line terminated at the bottom of the mast. One antenna is isolated from the other by 30 dB. Model DB224S-() consists of two omnidirectional antennas, each having a gain of 3 dBd.

SIDE MOUNTING

When the DB224-() and DB224E-() antennas are mounted to the side of a tower the horizontal radiation pattern necessarily becomes distorted. The patterns shown below indicate the typical pattern shape of the antenna side mounted on a tower with an 18" to 24" face using the DB5001 Side Mount Kit.

The DB5001 Side Mount Kit positions the antenna approximately 18" from the tower and consists of an upper sway brace, lower bracket (both galvanized) and the necessary hardware for attaching the bracket to round tower members up to 3" OD, or angular members up to 2" on a side. Other size clamps can be supplied on special order.

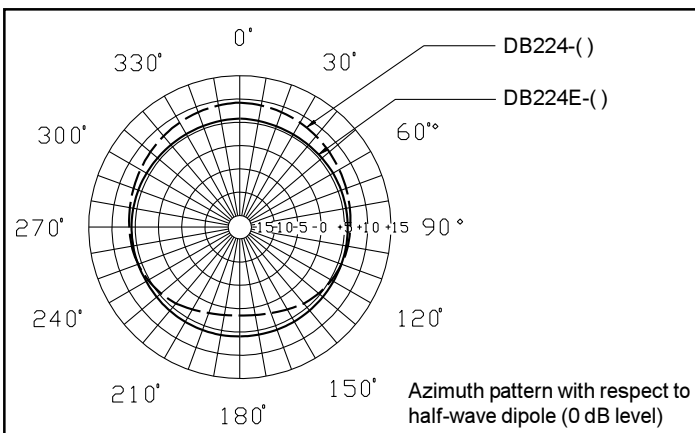

Figure 3. Radiation Patterns for Top Mounted DB224-() and DB224E-() Antennas.

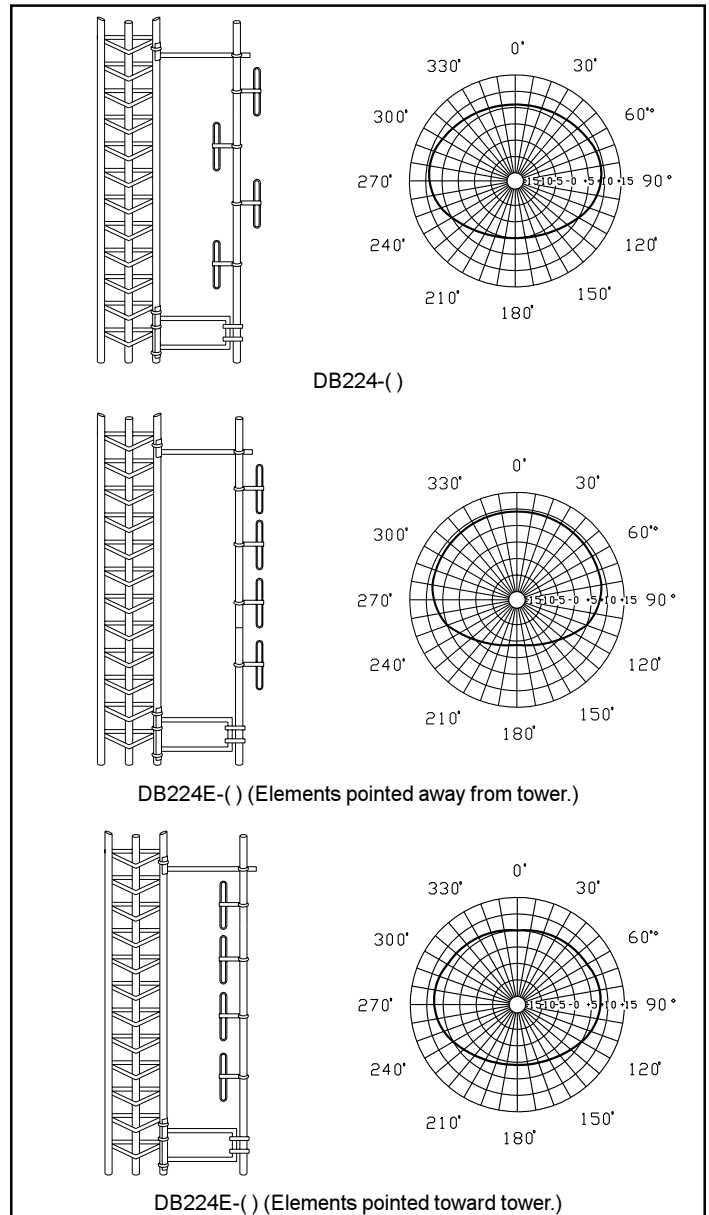

Figure 4. Radiation Patterns

INSTALLATION PROCEDURE

1. After removing the antenna from the shipping box, inspect it to be sure all parts are on hand and that there is no physical damage.
2. Inspect the antenna feed assembly output connector to determine that it mates with the end of your station transmission line. Do not remove any connectors or cables from the antenna feed assembly since they are all a part of the antenna.
3. Verify that the frequency to which the antenna has been tuned is the frequency on which your radio system is to operate.
4. Slip the mast sections together and position the bands as shown in Figure 5. Tighten the bands securely; the recommended tightening torque is 45-60 in-lbs. Then, join the connectors, making the connections snug, but do not apply heavy force with pliers. Carefully wrap VAPOR-WRAP™ (part no. 11317 or 11316) around the connection to seal out moisture problems. Secure the connectors to the mast with several wraps of tape (see Figure 5).
5. Attach the furnished DB365 mounting clamps to the bottom of the antenna mast at the designated locations. Mount the antenna on the tower with the bottom dipole above and facing away from the tower.
6. A check of the antenna VSWR as measured at the antenna is recommended at this point. Note this measurement carefully, and record it for future reference.
7. After checking the VSWR at the antenna, connect the station transmission line to the antenna; make the connection snug, but do not apply heavy force with pliers. To avoid moisture problems, carefully wrap VAPOR-WRAP™ (part no. 11317 or 11316) around the connection, smoothing it into the cracks and over the outer jackets of the transmission line. Failure to waterproof the cable connection can result in improper operation of your antenna. Properly secure the feeder cable and antenna transmission line to the tower in the best position to avoid physical damage to the cable.
8. After the antenna and transmission line installation has been completed, a careful check should be made to ensure that:
 - All mechanical connections have been securely made.
 - The antenna is mounted on the proper leg of the tower with sufficient physical clearance.
 - All connections have been carefully wrapped with VAPOR-WRAP™ to prevent moisture problems.

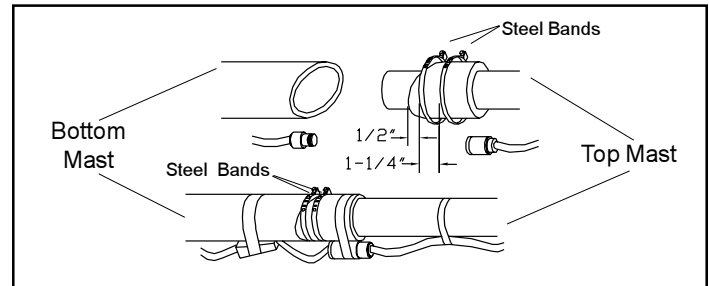

Figure 5. Joining the Mast Sections

This page intentionally left blank.



ANDREW[®]

Andrew Corporation
Base Station Antennas
8635 Stemmons Freeway
Dallas, TX U.S.A. 75247

Telephone: 1-800-676-5342
FAX (U.S.A.): 1-800-229-4706
Internet: www.andrew.com

Customer Service, 24 Hour: U.S.A. • Canada • Mexico: 1-800-255-1479
U.K.: 0800 250055
Other Europe: +44 1592 782612

Printed in U.S.A.
Copyright © 2003 by Andrew Corporation