

Mobile Communications

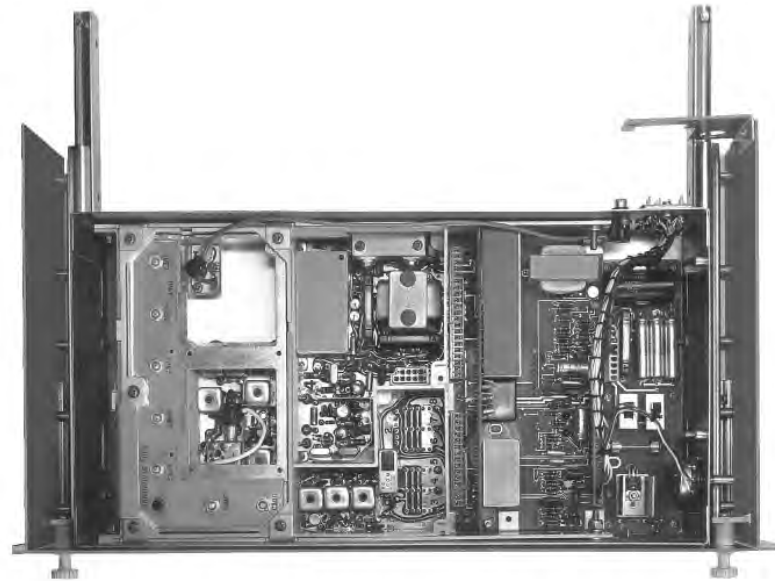

MASTR® II
AUXILIARY RECEIVER
19D417546G7 & G8
& ANTENNA MATCHING
UNITS
19C321150G1-G2

TABLE OF CONTENTS

	<u>Page</u>
SPECIFICATIONS	1
NOMENCLATURE CHART	2
DESCRIPTION	2
INSTALLATION	2
ADJUSTMENT	2
CIRCUIT ANALYSIS	3
10-Volt Regulator Board 19C320918G1	3
System Board 19D429764G1	3
Channel Guard Filter 19C320627G1	4
Tone Notch Filter 19C328328G3	4
Line Response Compensator 19C328328G2	4
Tone Notch Filter/Line Response Compensator 19C328328G1	4
Squelch Operated Relay 19C320913G1	4
Voting Tone Board 19C320879G1	4
Voting Tone Board 19C320879G2 (Option 9656)	4
Antenna Matching Units 19C321150G1 & G2	4
Power Supply 19C311855G1	4
OUTLINE DIAGRAMS	
Auxiliary Receiver Chassis 19D417546G7	5
Auxiliary Receiver Chassis 19D417546G8	6
Tone Notch Filter/Line Response Compensator 19C328328G1	7
Channel Guard Filter 19C320627G1	7
System Board 19D429764G1	8
Squelch Operated Relay 19C320913G1	9
10-Volt Regulator Board 19C320918G1	9
Antenna Matching Unit 19C321150G1	10
Power Supply 19C311855G1	10
SCHEMATIC DIAGRAMS	
Channel Guard Filter 19C320627G1	11
Tone Notch Filter 19C328328G3	11
Tone Notch Filter/Line Response Compensator 19C328328G1	12
Line Response Compensator 19C328328G2	13
Squelch Operated Relay 19C320913G1	14
Antenna Matching Units 19C321150G1 & G2	14
Auxiliary Receiver 19D417546G7 & G8	21
PARTS LISTS & PRODUCTION CHANGES	15
INSTALLATION & INTERCONNECTION DIAGRAMS	
Tone Notch Filter/Line Response Compensator	22
Auxiliary Receiver and Antenna Matching Unit	23
Auxiliary Receiver Overlay Harness	25
Auxiliary Receiver Overlay Harness (EACOM)	26
Auxiliary Receiver Overlay Harness With CG Monitor	27
ILLUSTRATION	
FIGURE 1 - TEST SET-UP DIAGRAM	3

SPECIFICATIONS*

DIMENSIONS (HXWXD)	3.5-inches x 10-inches x 13.5-inches
AUDIO OUTPUT	
Remote Line Level	2.7 Volts rms (+11 dBm) If receiver is used in Tone Remote Base Station, line level should be set at 1.0 Volt rms (+2.0 dBm)
Local Control VOLUME Adjust	6.3 Volts rms
ANTENNA MATCHING UNIT	
Power Divider Loss	3.5 dB
Output Impedance, each output port	50 ohms
Isolation Between each output port	20 dB (15 dB at 450-512 MHz)

* These specifications are intended primarily for the use of the serviceman. Refer to the appropriate Specification Sheet for the complete specifications.

WARNING

No one should be permitted to handle any portion of the equipment that is supplied with high voltage; or to connect any external apparatus to the units while the units are supplied with power. **KEEP AWAY FROM LIVE CIRCUITS.**

1st Digit	2nd Digit	3rd Digit	4th Digit	5th Digit	6th & 7th Digits	8th Digit
Package	Options	Channel Spacing	No. of Freq.	Options	Frequency Range	Oscillator Stability
R 12 VDC Rec. Without AMU	1 Standard	4 20kHz	A 1 Freq.	S Standard	12 25 - 30 MHz	A ± 5 PPM
M 12 VDC Rec. With AMU	2 Secur-it Tone Notch Filter	5 25 kHz		N Noise Blanker	13 30 - 36 MHz	
S 121 VAC Rec. Without AMU	3 Voting Tone Board	6 30 kHz	P Preamplifier	23 36 - 42 MHz	E ± 1 PPM	
T 121 VAC Rec. With AMU	4 Squelch Operated Delay		U Channel Guard	33 42 - 50 MHz		
	5 Notch Filter & Voting Board	W CG & NB	44 66 - 78 MHz			
	6 Notch Filter & SOR	G CG & Preamp	45 77 - 88 MHz			
	7 Line Response Compensator	56 138 - 150 MHz				
	8 Tone Notch Filter & Compensator	66 150.8-174 MHz				
	9 Compensator & Voting Tone Board	77 406-420 MHz				
	A Compensator & Squelch Operated Relay	88 450-470 MHz				
	B Compensator & Notch Filter & Voting Tone Board	89 470-494 MHz				
C Compensator & Notch Filter & Squelch Operated Relay	91 494-512 MHz					
					96 806-825 MHz	

DESCRIPTION

The MASTR® II Station Auxiliary Receivers are available for mounting in MASTR II Base Stations or in MASTR II Multiple Receiver Stations. The Auxiliary Receiver consists of a 2-rack unit shelf with space for the receiver RF circuits, the oscillator/multiplier, the IFAS and MIF assemblies together with a System Board and a 10-Volt Regulator Board. 13 VDC is required to power the shelf.

In MASTR II Base Station applications (Options 9538-9541), power for operating the Auxiliary Receiver is provided by the Base Station Power Supply. These options also include a 19B226307 Overlay Harness. Refer to the Interconnection Diagram listed in the Table of Contents.

In MASTR II Multiple Receiver Station applications, power for operating the receivers is provided by a power supply designed specifically for this station. Refer to LBI-30731.

Operating an auxiliary receiver in voting systems where no external power supply is available requires the use of the 19C31 1855G1 Power Supply. This supply is mounted on the rear panel of the receiver. No service speaker should be used with this supply.

The Auxiliary Receiver can be supplied with an Antenna Matching Unit (Options 9536 or 9537). A phone connector is used for interconnecting the receiver and AMU. When the receiver is not used with an AMU, a coaxial cable (19A129312G4) fitted with an auxiliary UHF antenna connector is provided. Refer to the Installation Instructions listed in the Table of Contents.

The Auxiliary Receiver System Board accommodates several option boards either individually or in combination. Option boards that plug into jacks on the System board include the Voting Tone Board (19C320880G1) used in Receiver Voting Systems or the Squelch Operated Relay (SOR) 19C320913G1, used in external control applications.

A Secur-it Tone Notch Filter (19C328328G3), used in Tone Remote Systems, mounts on the side of the receiver system board chassis. A Line Response Compensator Board (19C328328G2) is available for use in Voting Tone Systems. This compensator provides means for adjusting the audio response at the receiver end of a telephone line. A third version of this board (19C328328G1) includes both the tone notch filter and the line response compensator.

A Channel Guard Decode Board (19D417261G6) may be plugged into the System Board at P908 and P909. A Tone Reject Filter (19C320627G1) is used with the Channel Guard Decode Board to prevent the CG tone from being fed into the telephone line. The filter attenuates below 203.5 Hertz.

The 13-Volt DC input to the 10-Volt regulator is fused. A Light Emitting Diode (LED) is provided on the front panel of the receiver to indicate when power is applied. A power ON-OFF switch is provided on the regulator board. Another LED on the front panel indicates carrier activity. The receiver chassis swings out for servicing.

INSTALLATION

The Auxiliary Receiver is installed directly above the station power supply in MASTR II Base Stations. The 19C321150 Antenna Matching Unit is located directly above the Receiver. Refer to the Installation Diagram (See Table of Contents). Refer to the Installation Instructions in LBI-30761 for mounting the Auxiliary Receiver in the Multiple Receiver Station.

ADJUSTMENT

The initial adjustment for the receiver includes tuning the input circuit to match the antenna. Refer to the FRONT END ALIGNMENT PROCEDURE IN THE MAINTENANCE MANUAL for the receiver.

MASTR II REMOTE CONTROL STATION ADJUSTMENT

To adjust the LINE LEVEL control R936, located on the System Board, use the following procedure.

1. Connect a signal generator to the Auxiliary Receiver antenna jack J2402. Set the generator to the receiver frequency. Modulated at 3 kHz deviation by a 1000 Hz signal. Disable Channel Guard (if present) by opening switch S802 on the Regulator Board.
2. Adjust the LINE LEVEL control R936 on the System Board for a reading of 2.7-volts rms (+11 dBm) as measured at the base station audio pair.

If the receiver is used with a Tone Control Base Station, adjust the LINE LEVEL control for a reading of 1.0-volt rms (+2 dBm).

To adjust the VOL SET control R930 and the SQUELCH control R2401, use the following procedure.

1. Connect an 8.2 ohm, 1-watt resistor across J2401-9 and 10, located on the rear panel of the Auxiliary Receiver.
2. Connect an AC vtm across the 8.2 ohm resistor and adjust R930 for a reading of 2.7-volts rms on the meter.
3. Disconnect the 8.2 ohm resistor. Disconnect the signal generator.

4. Turn the SQUELCH control R2401 clockwise (to the right) as far as possible.
5. Adjust the VOLUME control R3 on the 19C320728 service speaker until the noise is easily heard in the speaker but is not annoyingly loud.
6. Turn the SQUELCH control counter-clockwise (to the left) until the noise just disappears, then advance the control another 20 degrees.

MASTR II LOCAL CONTROL BASE STATIONS

To adjust the VOL SET control R930 and the SQUELCH control R2401, use the following procedure.

1. Apply a 1000 microvolt on-frequency signal modulated by 1,000 Hz with ± 3 kHz deviation to the Auxiliary Receiver Antenna Jack J2402.
2. Disconnect MASTR Local Controller cable from station input (PI 102 from J1).
3. Connect an 8.0 ohm, 5-watt resistor across J2401-9 and 10, located at the rear of the Auxiliary Receiver.
4. Connect an AC vtm across the 8.0 ohm resistor and adjust R930 for a reading of 6.3-volts rms on the meter.
5. Disconnect the 8.0 ohm resistor and connect the controller cable to the station. Disconnect the signal generator from J2402.
6. Turn the SQUELCH control (R2401) clockwise (to the right) as far as possible.
7. Adjust the VOLUME control on the MASTR Local Controller until the noise is easily heard in the controller speaker but is not annoyingly loud.
8. Turn the SQUELCH control counter-clockwise (to the left) until the noise just disappears, then advance the control another 20 degrees.

LINE COMPENSATOR ADJUSTMENT, R12, R19

Test Equipment Required

1. Signal Generator
2. Audio Oscillator

3. AC Voltmeter

Procedure

R12 in the line compensator is used to set the 3000 Hz level. R19 is used to set the 300 Hz level. A Test Set-up Diagram is shown in Figure 1.

1. At the Satellite Receiver, apply a 1000 millivolt, 1 kHz signal with 3 kHz deviation from the signal generator to the receiver as shown in Figure 1. Adjust LINE OUTPUT potentiometer R936 on Auxiliary Receiver System Board for a reading of 0 dBm.
2. Record this level as measured at telephone line input of the voting selector, then remove the signal generator.
3. Connect the audio oscillator to the input of the line compensator (Hole 14 on the Line Compensator Board or J908 on the Auxiliary Receiver System Board). Set the oscillator frequency to 1000 Hz, and adjust the level to produce the same level recorded at the voting selector input in Step 2.
4. Record the output level of oscillator.
5. Change the oscillator frequency to 2800 Hz. Maintain same oscillator output level as recorded in Step 4.
6. Adjust R12 on the line Compensator Board to produce the same level recorded at the voting selector in Step 2.
7. Change the oscillator frequency to 300 Hz. Maintain same oscillator level as recorded in Step 4.
8. Adjust R19 on line compensator to produce the same phone line level at the voting selector as recorded in Step 2.

CIRCUIT ANALYSIS

10-VOLT REGULATOR BOARD 19C320918G1

The hybrid integrated circuit U801 includes the 10-Volt Regulator and regulator amplifier. Regulator pass transistor Q801 is mounted to the heat sink located on the printed board. The regulator circuit provides a closely controlled supply voltage for the receiver, Channel Guard and other options when present. Input voltage (A+) for the regulator is supplied from the station power supply via J2401-2 or some other external source.

The Auxiliary Receiver ON/OFF switch S801 (located on the Regulator Board) is normally left in the ON position. Turn-

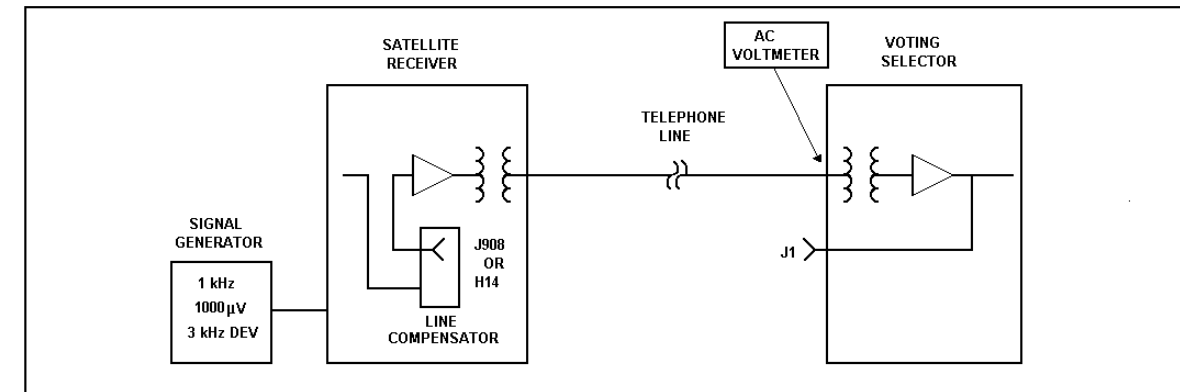

Figure 1 - Test Set-up Diagram

ing on the station power supply applies voltage through S801 and input filter C801-L801 to pin 1 of the regulator hybrid U801. The regulator amplifier output at pin 2 of U801 is applied to the base of Q801, causing Q801 to conduct. The voltage at pin 3 of U801 is the regulated 10-volts output. A high impedance source at pin 5 of U801 provides a stable 5-volt compensation input to the receiver ICOM.

Two LEDs are provided on the front panel of the Receiver. LED CR801 (ON) indicator is illuminated when power is applied to the regulator and switch S801 is in the ON position. When a signal is received, the received un-squelch sensor (RUS) voltage developed by the receiver operates the RUS switch Q909 on the System Board. Conduction of Q909 operates Q802 on the regulator board. Conduction of Q802 turns on LED CR802 (CARRIER ACTIVITY light).

SYSTEM BOARD 19D429764G1

The Auxiliary Receiver System Board contains the VOL SET control R930, the de-emphasis and line driver circuits for remote control applications, and jacks which accommodate the various options available. The System Board also mates directly with the receiver modules through J903 and J904.

VOLUME/SQUELCH HI from the receiver audio pre-amp is connected via J904-11 to the VOL SET control R930 and SQUELCH control R2401. The VOL SET arm is returned to the receiver IFAS Board where the audio is amplified by the receiver audio power amplifier circuit. The audio output of the PA is then connected to the speaker leads at J2401-9 and 10. The station VOL SET control is normally adjusted for 5-watts output and the speaker level is controlled by the MASTR Local Controller VOLUME control. In multiple-receiver applications, the jumper between H1 and H2 on the 19C320918 regulator board is removed, disconnecting A+ from the receiver PA output transformer. This al-

lows the audio to be applied to the Multiple Receiver PA and speaker and limits the current drain requirements.

In MASTR II remote applications, the VOL/SQ HI is coupled through the LINE DRIVER circuits to the remote audio pair. The audio is connected through the high-pass filter consisting of C907-C908 and R901-R902. This filter attenuates 60 and 120 Hertz to reduce the hum and noise. The output of emitter-follower Q901 is passed through a de-emphasis network C909 and R906. This network provides a 6 dB/octave rolloff. The signal is then amplified by Q902 and fed to another emitter follower Q903.

The audio is coupled to the line driver through C914, Q904 amplifies the signal. The LINE LEVEL control R936 is connected in the collector circuit of Q904 and allows feeding the audio to the line driver Q907. Q906 serves as an audio switch controlled by the RUS circuit. As long as the RUS switch Q909 is turned off (receiver squelched), CR905 is forward biased allowing Q906 to conduct. Conduction of Q906 grounds the audio path between Q904 and Q907, preventing the audio from being passed to the line. When the receiver unsquelches, the RUS lead goes high. This turns Q909 on, turning off CR905 and Q906. The audio is now allowed to pass to the output amplifier Q908 or to the line transformer T901. CR902, CR903 and VR901 are provided for line-surge protection.

When the 19D417261G6 Channel Guard Board is used, the RX MUTE lead is controlled by the Channel Guard Board. When no CG tone of the proper frequency is present, the board holds the RX MUTE lead at ground potential. When a CG tone of the proper frequency is detected, the ground on the RX MUTE lead is removed and the RUS lead will then go high when the receiver squelch opens. Activating the CG MONITOR switch at the station control unit causes the Channel Guard Board to remove ground from the RX MUTE lead, allowing the receiver to operate on noise squelch.

CHANNEL GUARD FILTER 19C320627G1

The Channel Guard filter attenuates frequencies below 203.5 Hz to prevent the Channel Guard tone from being applied to the line. The filter board is plugged into the System Board at P906 and P907.

Audio and tone is applied to the filter input (J1-1) from the pre-amp. The audio is coupled to the 187 Hz notch filter composed of Q1, Q2 and associated circuitry. Negative feedback for the filter is connected from the collector of Q2 to the junction of C2-R2.

The notch filter output is applied to a low-pass filter consisting of Q3 and Q4. Negative feedback is developed across R12. The output of Q4 is coupled to the output lead J2-3 through C9 and returned to the preamp circuit.

TONE NOTCH FILTER 19C328328G3

In Tone Remote Systems the tone notch filter is used for removing the 2175 Hz Secur-it tone from the audio path. The audio is connected to the filter at J906 on the System Board. The filter is composed of series resonant shunts L1-C1 and L3-C3 along with parallel resonant trap L2-C2. The filter notches out the 2175 Hz component from the audio and returns the audio to the System Board via J905. Resistor R937 is removed in Tone Remote Systems.

LINE RESPONSE COMPENSATOR 19C328328G2

A telephone line usually introduces attenuation as a function of frequency to the audio signal. The line response compensator introduces gain at the appropriate frequencies with the net effect being a flat frequency response.

Audio applied to the compensator input at J908 on the System Board is amplified by buffer amplifier AR1-D and applied to the two active bandpass filters AR1-A and AR1-B. The 300 Hz and 3000 Hz filters boost the audio at these frequencies and the result is summed by the low-Q 1000 Hz fil-

ter AR1-C. This 1000 Hz filter provides the required attenuation for a resultant response control from -1 to +10dB at 3000 Hz, 3000 Hz referenced to the 1000 Hz level. Gain control R12 is adjusted at the factory and should require no further adjustment. The compensator output is applied to J909 on the System Board. The +10 Vdc for operating the compensator circuits is applied via J910 on the System Board.

TONE NOTCH FILTER/LINE RESPONSE COMPENSATOR 19C328328G1

The 19C328328G1 board combines the tone notch filter and line response compensator in systems requiring both functions.

SQUELCH OPERATED RELAY BOARD 19C320913G1

The Squelch Operated Relay (SOR) Board plugs into the Auxiliary Receiver System Board at the P902 position. The SOR provides four set of Form "C" relay contacts. A harness (19A122717G5) is provided for connecting any two sets of the Form "C" contact pines. The contacts of the relay are rated at 2 Amperes, for either 24 VDC or 121 VAC application.

When a signal is received and the receiver unscquelches, a positive voltage appears on the RUS line at P904-8. This positive voltage is applied to the base of Q1, turning the transistor on. Conduction of Q1 operates Q2. Conduction of Q2 turns on Q3 which, in turn, energizes relay K1.

VOTING TONE BOARD 19C320880G1

The Voting Tone Board is used in Voting Selector Systems and is plugged into the same plug (P902) which accommodates the SOR Board. Thus both of these options cannot be used simultaneously. Refer to LBI-4913 for a description of the Voting Tone Board.

VOTING TONE BOARD 19C336900G1

The Voting Tone Board is used to provide tone signaling and is plugged into the same plug (P902) which accommodates the SOR Board. Thus both options cannot be used simultaneously. Refer to LBI-31981 for more information on this board.

VOTING TONE BOARD 19C328276G2 (Option 9656)

The 19C328276G2 Voting Tone Board is used in Voting Systems when test tones are desired for line response adjustment. The test tones are normally 400, 1000 and 2500 Hz with optional status tone of 1600, 2175 and 2400 Hz available. Three momentary pushbutton switches are provided for enabling each of the test tones. The 19C328276G2 Voting Tone Board is described in LBI-30767.

ANTENNA MATCHING UNITS (Options 9536-9537)

The Antenna Matching Units (AMU) are designed to match two or more (up to a total of four) receivers to a single antenna. The AMUs may be operated with any receiver having an input impedance of approximately 50 ohms. The AMU chassis is designed for standard rack mounting. The frequency range of both units are listed in the following chart.

OPTION	9536 & 9703	9537 & 9704
MODEL	19C321150G1	19C321150G2
Freq. Range in Megahertz	42.5-174 MHz	450-512 MHz
Power Dividers	Z1,Z2,Z3	Z4,Z5,Z6

Antenna Matching Unit Options 9536 and 9537 are used with MASTR II Base Station Auxiliary Receiver applications. Options 9703 and 9704 are used with MASTR II Multiple Receiver Stations.

The receive antenna is connected to J1 on the AMU. The antenna cable W1 is connected to the input jack J1 on the first power divider (Z1 or Z4). The two outputs of the first power divider (J2 and J3) are coupled to the input jacks of two other power dividers which, in turn, feed up to four receivers. Each power divider has a 3.5 dB loss and 20 dB isolation (15 dB in the 450-512 MHz unit) between output posts. The characteristic impedance of all four receiver output posts on the power dividers is 50 ohms to match the input impedance of the receivers. If only two receivers are used with an AMU, the insertion loss can be reduced by 3.5 dB if only one power divider is used.

POWER SUPPLY 19C311855G1

The 19C311855G1 Power Supply is used when more than one auxiliary receiver is used in the MASTR II station. The 120-Volt, 50/60 Hz supply provides the required +13 Volts for operating the receiver.

Connecting P501 to a voltage source applies 120 VAC to the primary of stepdown transformer T501. The AC voltage developed across the secondary windings of T501 is rectified by full-wave bridge rectifiers CR501 through CR504. The rectified output is filtered by C501 and regulated by VR501 and Q501. The +13 V output is connected through P502 and P503 to P1-1 and P1-2 on the 19B226440G2 harness.

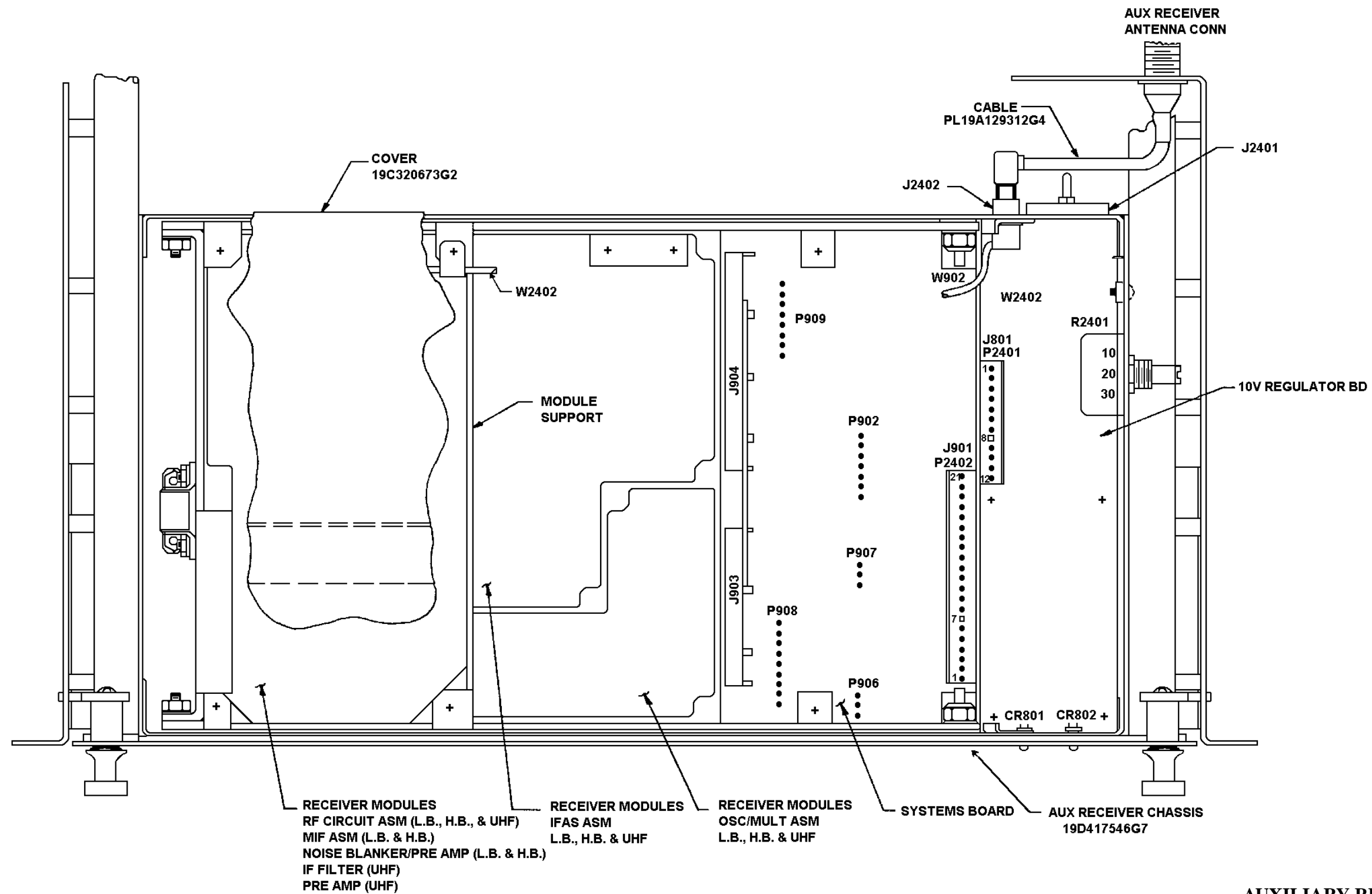

**AUXILIARY RECEIVER CHASSIS
LO-BAND, HI-BAND & UHF
19D417546G7**

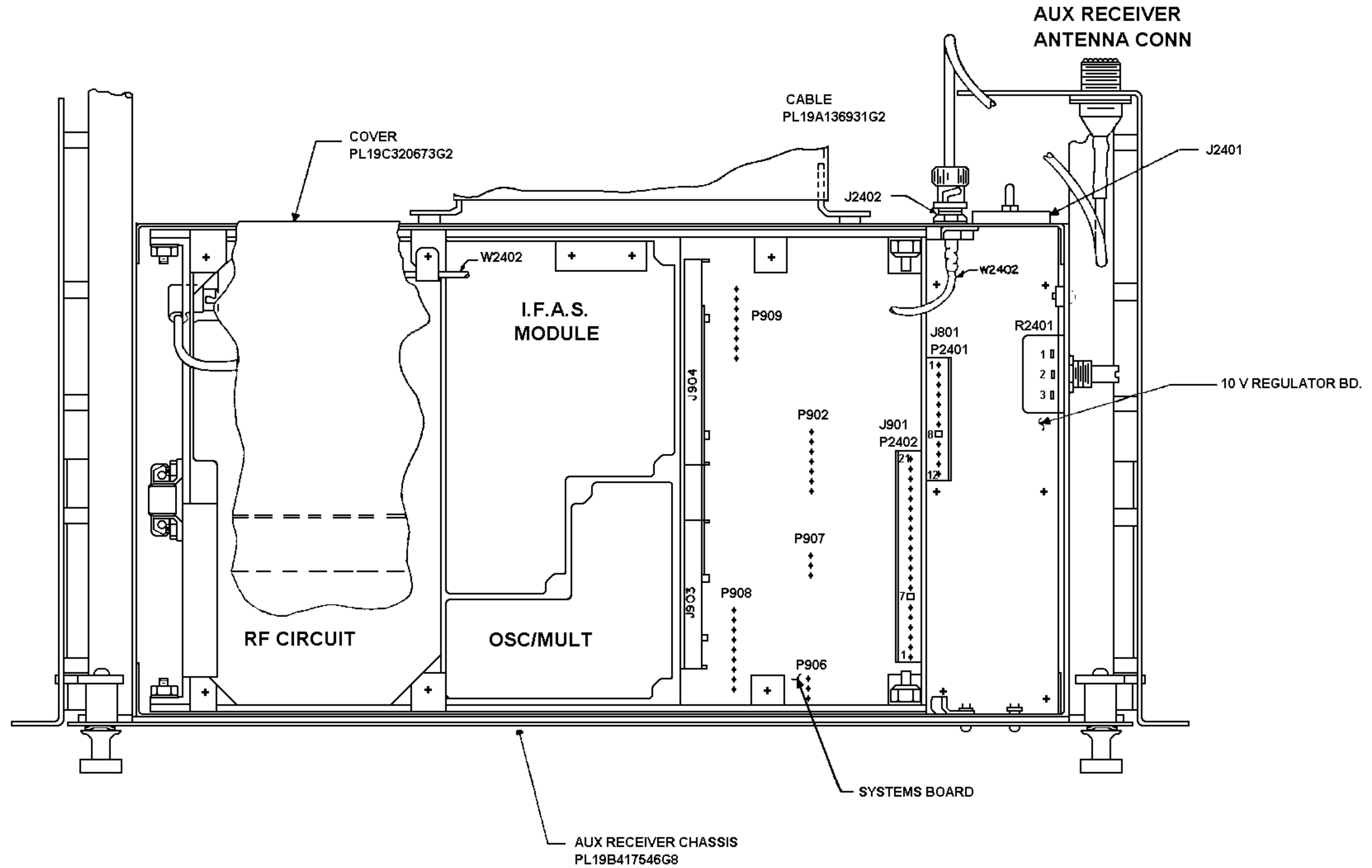

800 MHz AUXILIARY RECEIVER CHASSIS
19D417546G8

CHANNEL GUARD FILTER 19C320627G1

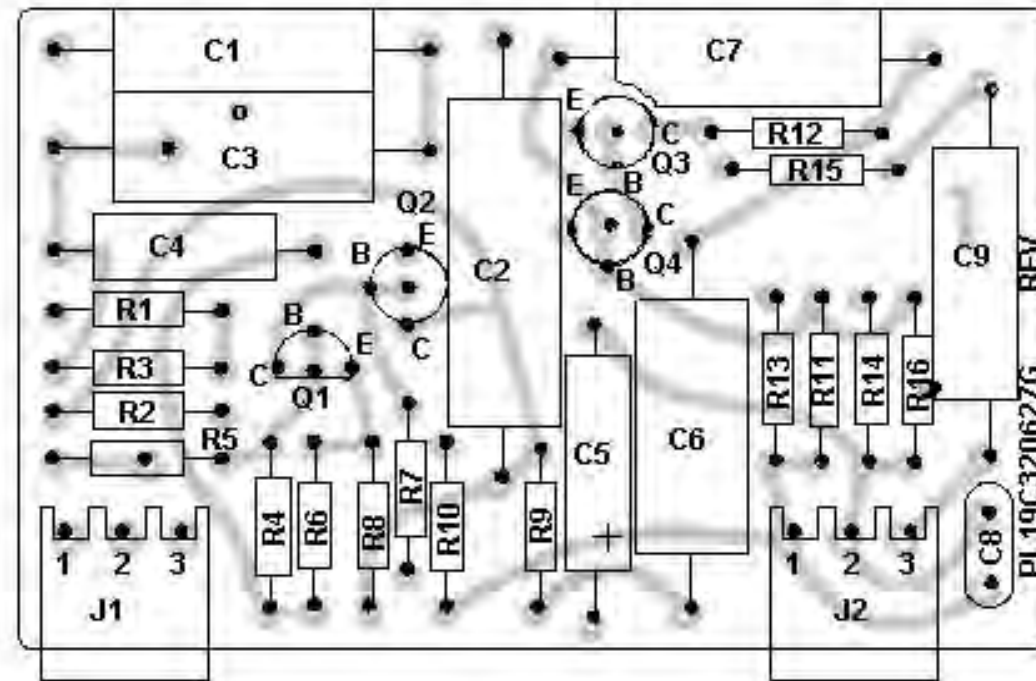

(19C321338, Rev. 1)
(19C320625, Sh. 2, Rev. 1)

TONE NOTCH FILTER/LINE RESPONSE COMPENSATOR 19C328328G1-G3

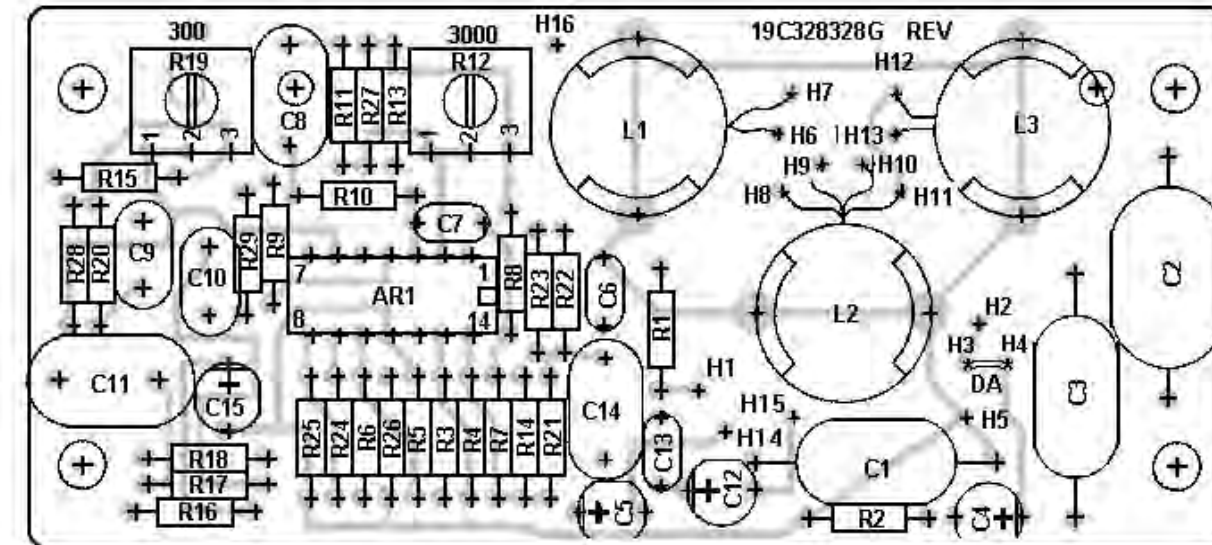

(19C328331, Rev. 0)
(19B232614, Sh. 1, Rev. 0)

LEAD IDENTIFICATION FOR Q1 - Q4

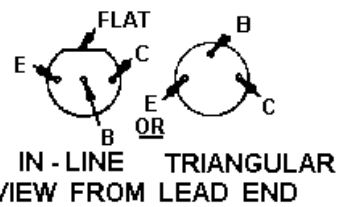

NOTE: LEAD ARRANGEMENT, AND NOT CASE SHAPE, IS DETERMINING FACTOR FOR LEAD IDENTIFICATION.



CAUTION
OBSERVE PRECAUTIONS FOR HANDLING ELECTROSTATIC SENSITIVE DEVICES

CHANNEL GUARD & TONE NOTCH FILTERS
19C320627G1 19C328328G1-G3

AUXILIARY RECEIVER SYSTEM BOARD 19D429764G1

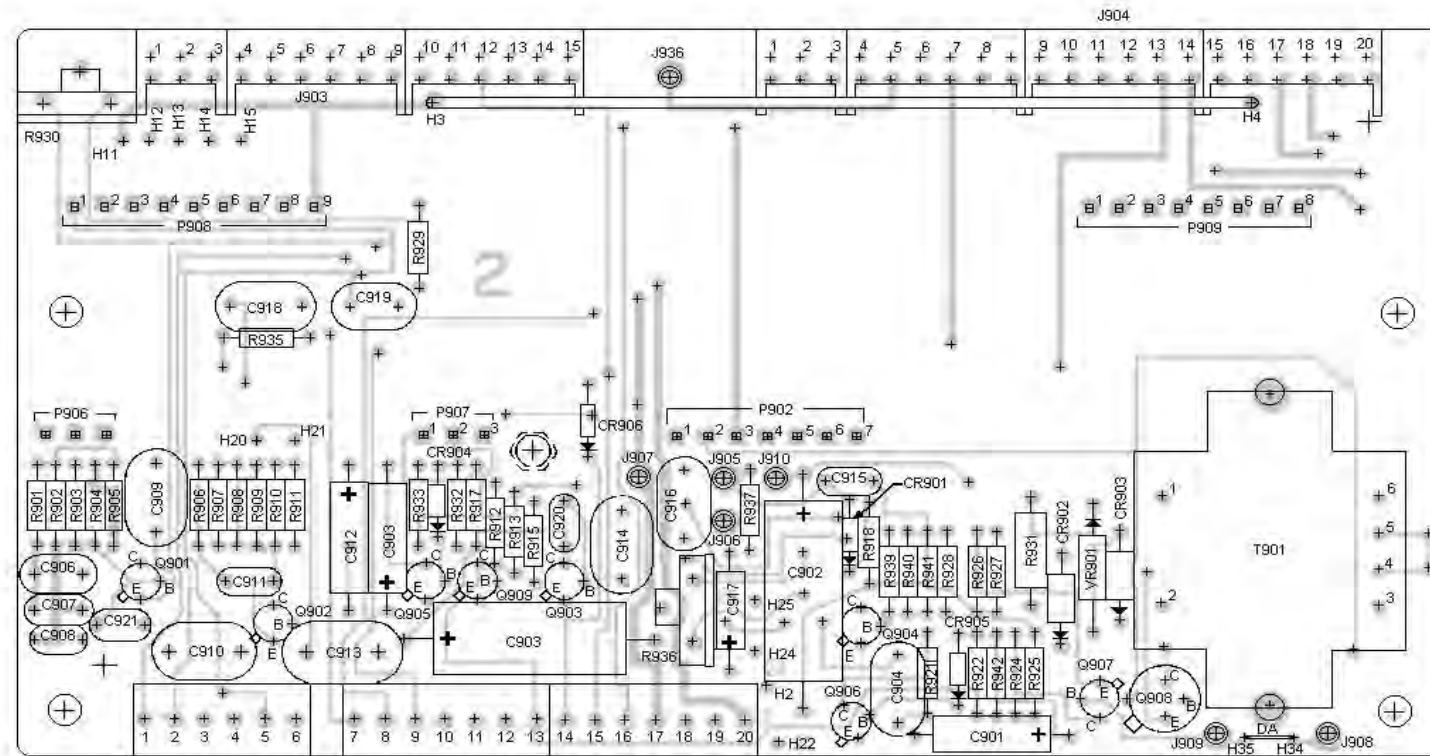

LEAD IDENTIFICATION FOR Q901-Q907, Q909

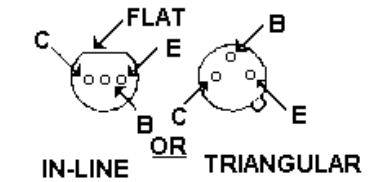

TOP VIEW

NOTE: LEAD ARRANGEMENT, AND NOT CASE SHAPE, IS DETERMINING FACTOR FOR LEAD IDENTIFICATION.

LEAD IDENTIFICATION FOR Q908

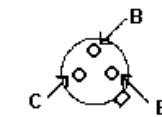

TRIANGULAR TOP VIEW

(19D429765, Rev. 2)
(19B232874, Sh. 1, Rev. 2)



CAUTION
OBSERVE PRECAUTIONS
FOR HANDLING
ELECTROSTATIC
SENSITIVE
DEVICES

AUXILIARY RECEIVER SOR BOARD 19C320913G1

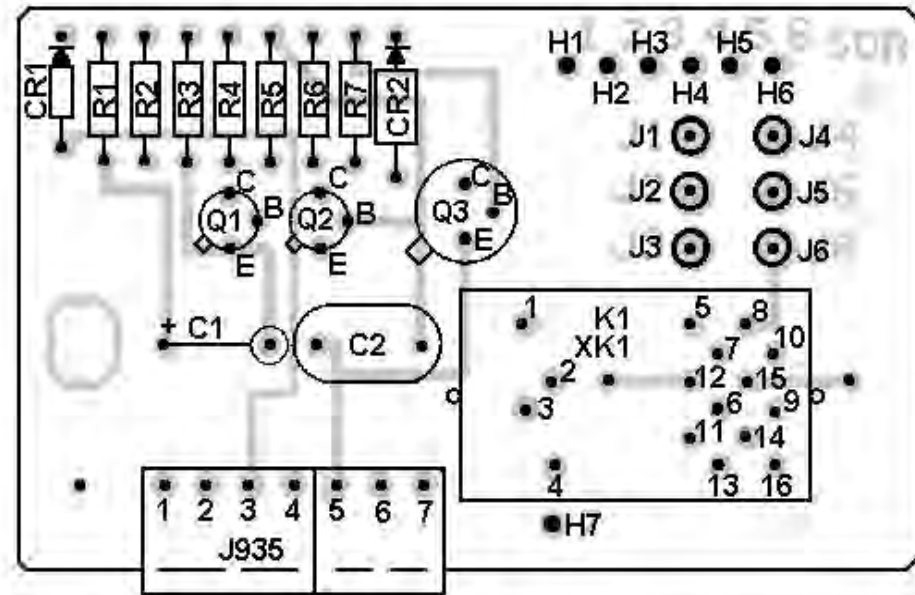

(19C321796, Rev. 1)
(19A130059, Sh. 1 & 2, Rev. 0)

10-VOLT REGULATOR 19C320918G1

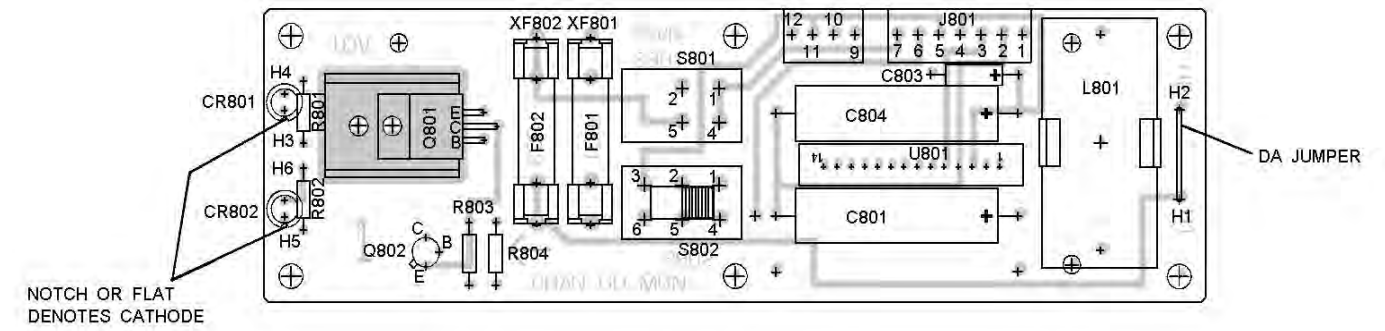

(19C321792, Rev. 4)
(19B226221, Sh. 1 & 2, Rev. 1)

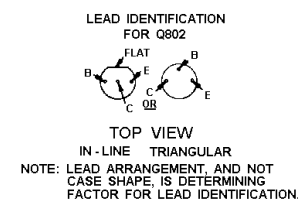
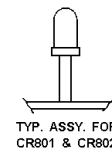

LEAD IDENTIFICATION
FOR Q1 & Q2

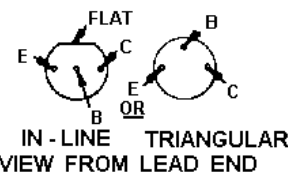

LEAD IDENTIFICATION
FOR Q3

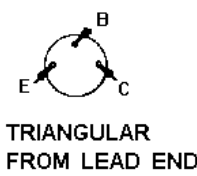

CAUTION
OBSERVE PRECAUTIONS
FOR HANDLING
ELECTROSTATIC
SENSITIVE
DEVICES

ANTENNA MATCHING UNITS 19C321150G1 & G2

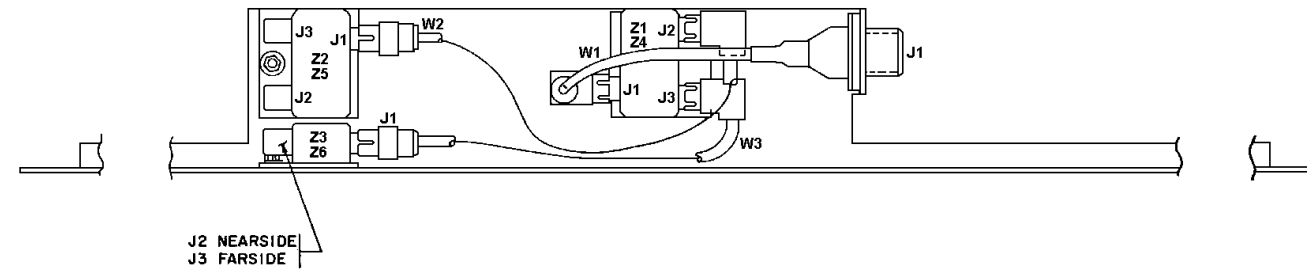

CAUTION
OBSERVE PRECAUTIONS
FOR HANDLING
ELECTROSTATIC
SENSITIVE
DEVICES

POWER SUPPLY 19C311855G1

POWER SUPPLY 19C311855G1

REAR VIEW OF AUXILIARY RECEIVER

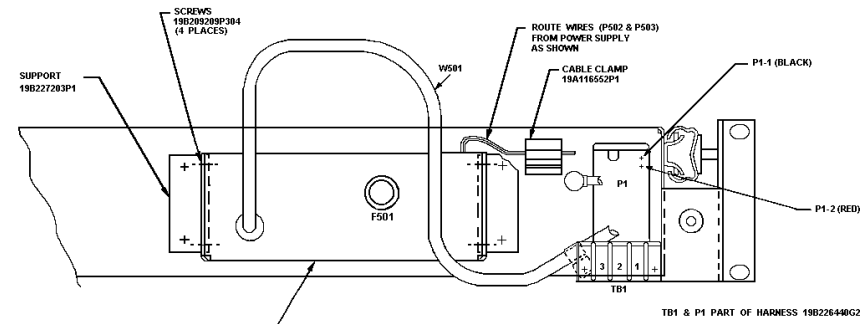

POWER SUPPLY 19C311855G1

P582 (RED) FROM POWER SUPPLY CONNECTS TO P1-2 (RED)
P583 (BLACK) FROM POWER SUPPLY CONNECTS TO P1-1 (BLACK)

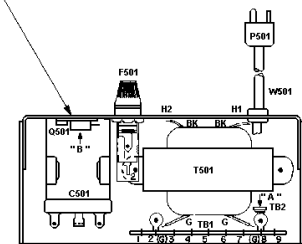

TERMINAL VIEW



BOTTOM VIEW



VIEW "B"



VIEW "A"



ANTENNA MATCHING UNITS AND POWER SUPPLY
19C321150G1 & G2 19C311855G1

(19C321706, Rev. 0)

(19C311855, Rev. 5)

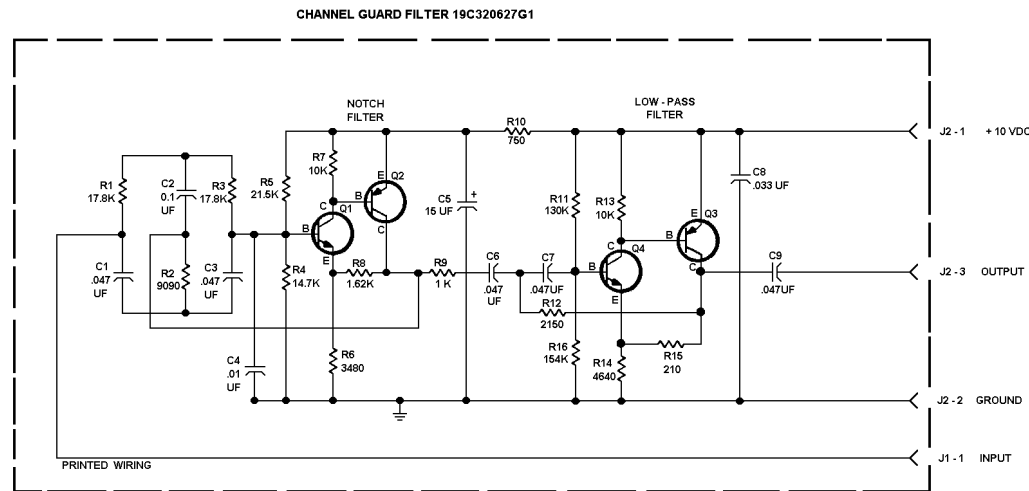

ALL RESISTORS ARE 1/4 WATT UNLESS OTHERWISE SPECIFIED AND RESISTOR VALUES IN OHMS UNLESS FOLLOWED BY K = 1000 OHMS OR MEG = 1,000,000 OHMS. CAPACITOR VALUES IN PICOFARADS (EQUAL TO MICROMICROFARADS) UNLESS FOLLOWED BY UF = MICROFARADS. INDUCTANCE VALUES IN MICROHENRYS UNLESS FOLLOWED BY MH = MILLIHENRYS OR H = HENRYS.

IN ORDER TO RETAIN RATED EQUIPMENT PERFORMANCE, REPLACEMENT OF ANY SERVICE PART SHOULD BE MADE ONLY WITH A COMPONENT HAVING THE SPECIFICATIONS SHOWN ON THE PARTS LIST FOR THAT PART.

SEE APPLICABLE PRODUCTION CHANGE SHEETS IN INSTRUCTION BOOK SECTION DEALING WITH THIS UNIT. FOR DESCRIPTION OF CHANGES UNDER EACH REVISION LETTER.

THIS ELEM DIAG APPLIES TO	
MODEL NO	REV LETTER
PL19C320627G1	

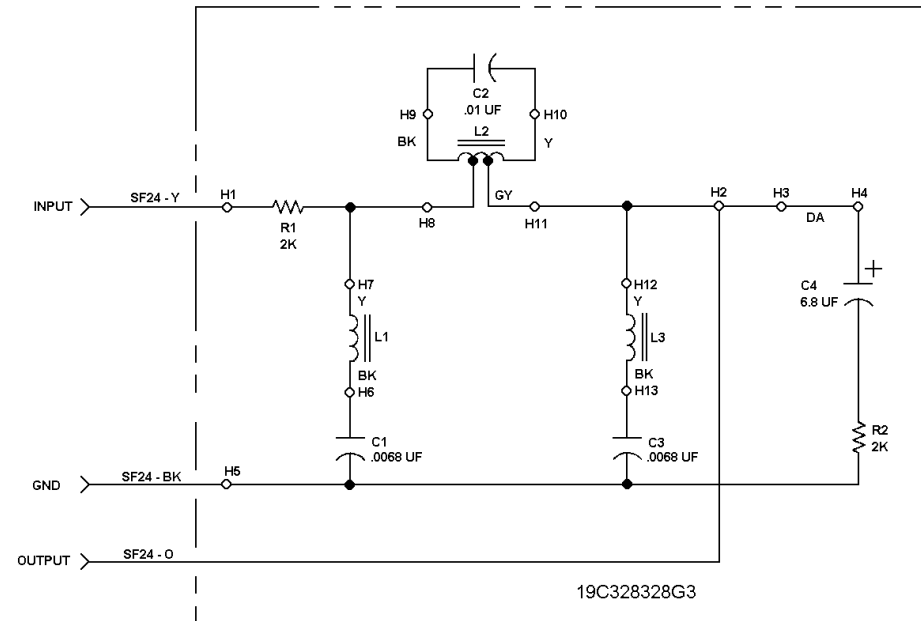

ALL RESISTORS ARE 1/4 WATT UNLESS OTHERWISE SPECIFIED AND RESISTOR VALUES IN OHMS UNLESS FOLLOWED BY K = 1000 OHMS OR MEG = 1,000,000 OHMS. CAPACITOR VALUES IN PICOFARADS (EQUAL TO MICROFARADS) UNLESS FOLLOWED BY UF = MICROFARADS. INDUCTANCE VALUES IN MICROHENRYS UNLESS FOLLOWED BY MH = MILLIHENRYS OR H = HENRYS.

MODEL NO	REV LETTER
PL19C328328G3	

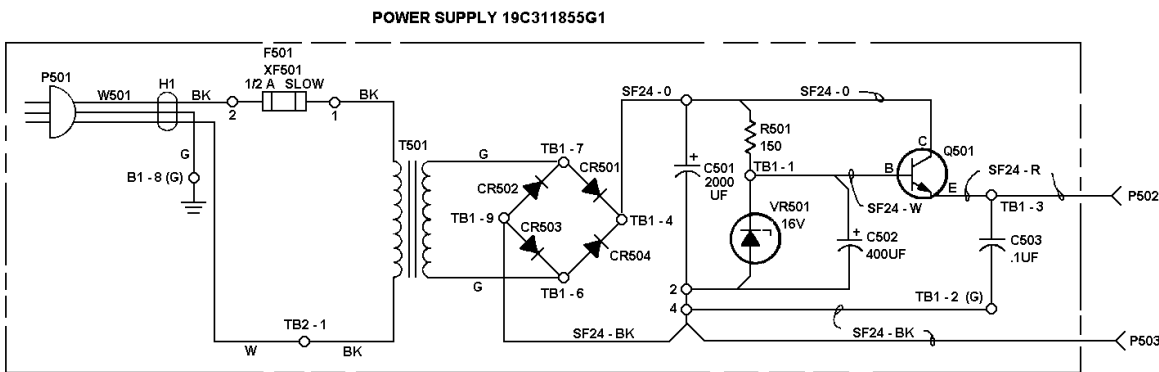

ALL RESISTORS ARE 1/4 WATT UNLESS OTHERWISE SPECIFIED AND RESISTOR VALUES IN OHMS UNLESS FOLLOWED BY K = 1000 OHMS OR MEG = 1,000,000 OHMS. CAPACITOR VALUES IN PICOFARADS (EQUAL TO MICROFARADS) UNLESS FOLLOWED BY UF = MICROFARADS. INDUCTANCE VALUES IN MICROHENRYS UNLESS FOLLOWED BY MH = MILLIHENRYS OR H = HENRYS.

SEE APPLICABLE PRODUCTION CHANGE SHEETS IN INSTRUCTION BOOK SECTION DEALING WITH THIS UNIT. FOR DESCRIPTION OF CHANGES UNDER EACH REVISION LETTER.

THIS ELEM DIAG APPLIES TO	
MODEL NO	REV LETTER
19C311855G1	C

IN ORDER TO RETAIN RATED EQUIPMENT PERFORMANCE, REPLACEMENT OF ANY SERVICE PART SHOULD BE MADE ONLY WITH A COMPONENT HAVING THE SPECIFICATIONS SHOWN ON THE PARTS LIST FOR THAT PART.

CHANNEL GUARD FILTER AND POWER SUPPLY
19C320627G1 **19C311855G1**

(19C320628, Rev. 0)

(19B216280, Rev. 5)

TONE NOTCH FILTER
19C328328G3

(19C328343, Rev. 1)

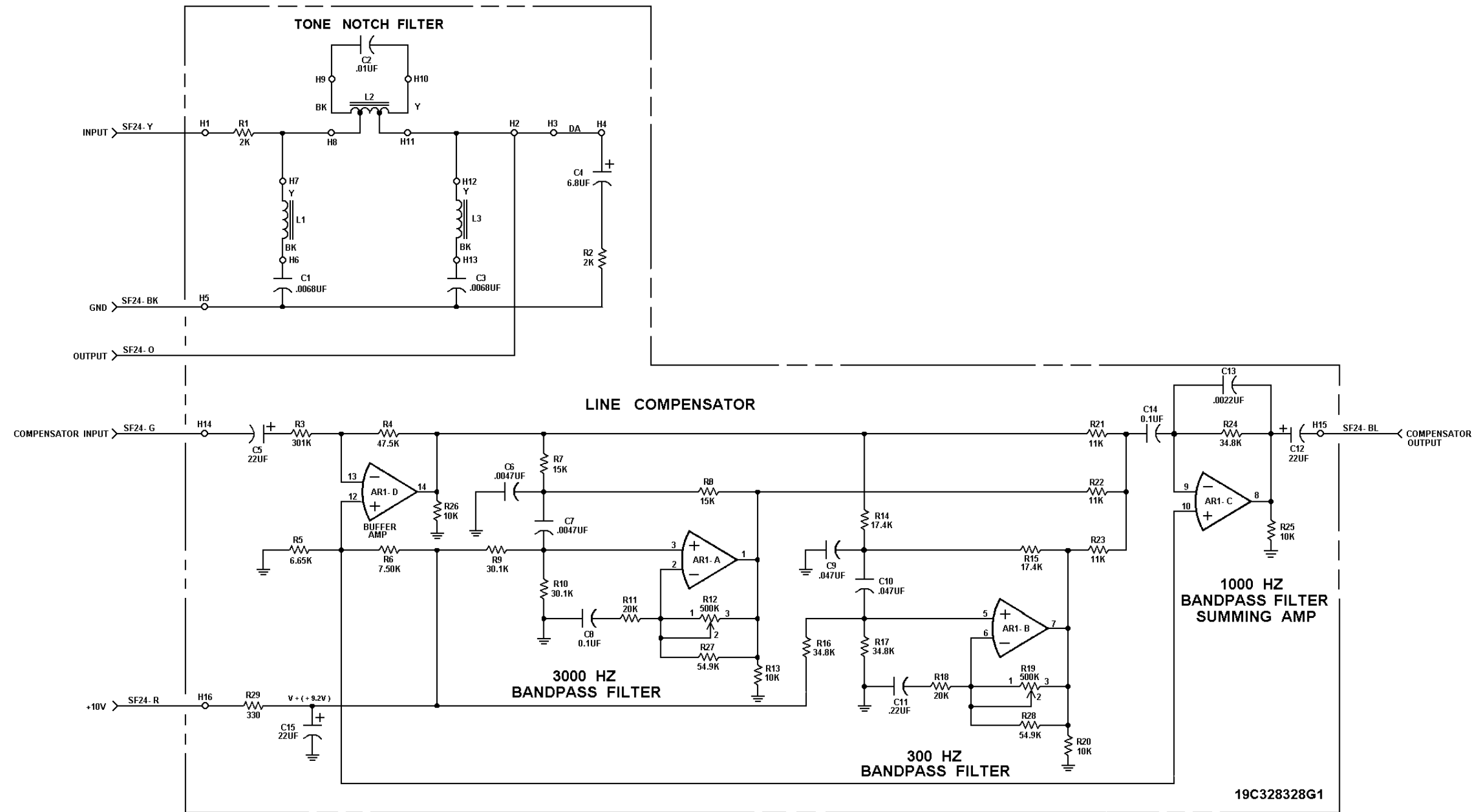

NOTES:
 1. PIN 4 OF AR1 IS CONNECTED TO V+.
 PIN 11 OF AR1 IS CONNECTED TO GROUND.

ALL RESISTORS ARE 1/4 WATT UNLESS OTHERWISE SPECIFIED AND RESISTOR VALUES IN OHMS UNLESS FOLLOWED BY K-1000 OHMS OR MEG-1,000,000 OHMS. CAPACITOR VALUES IN PICOFARRADS (EQUAL TO MICROMICROFARRADS) UNLESS FOLLOWED BY UF-MICROFARRADS. INDUCTANCE VALUES IN MICROHENRYS UNLESS FOLLOWED BY MH-MILLIHENRYS OR H-HENRYS.

MODEL NO	REV LETTER
19C328328G1	

**LINE RESPONSE COMPENSATOR
 19C328328G1**

(19D429483, Rev. 1)

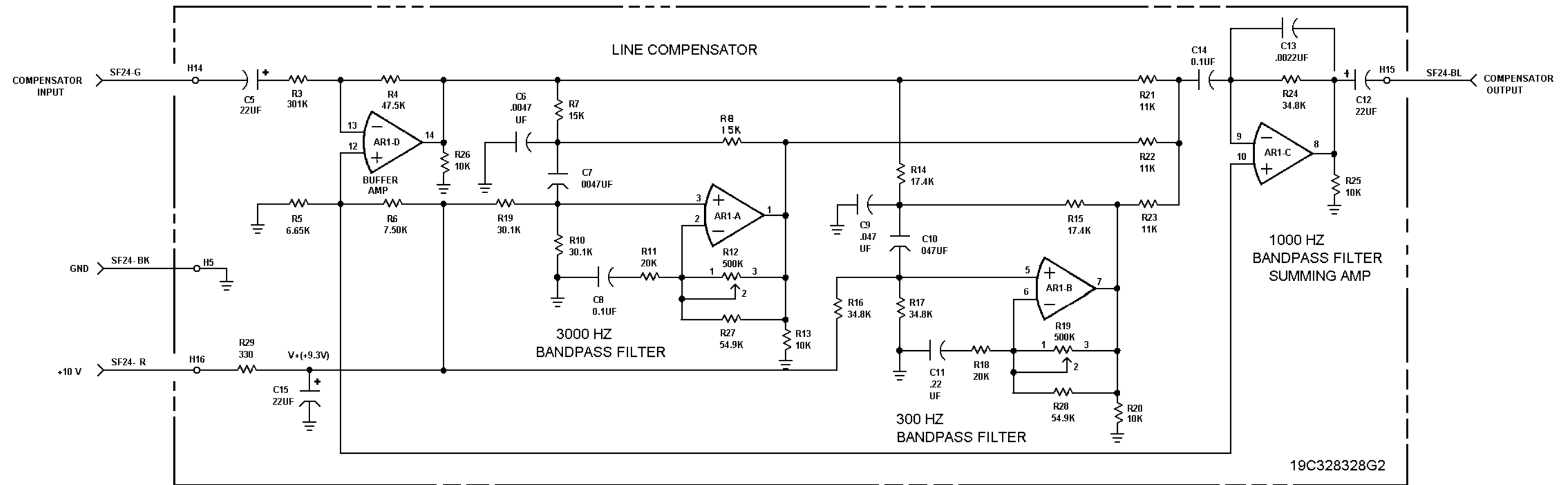

ALL RESISTORS ARE 1/4 WATT UNLESS OTHERWISE SPECIFIED AND RESISTOR VALUES IN OHMS UNLESS FOLLOWED BY K=1000 OHMS OR MEG=1,000,000 OHMS. CAPACITOR VALUES IN PICO FARADS (EQUAL TO MICROMICROFARADS) UNLESS FOLLOWED BY UF=MICROFARADS. INDUCTANCE VALUES IN MICROHENRYS UNLESS FOLLOWED BY MH=MICROHENRYS OR H=HENRYS.

- NOTES:
 1. PIN 4 OF AR1 IS CONNECTED TO V+.
 PIN 11 OF AR1 IS CONNECTED TO GROUND.

MODEL NO.	REV LETTER
19C328328G2	

LINE RESPONSE COMPENSATOR
 19C328328G2

(19D429481, Rev. 2)

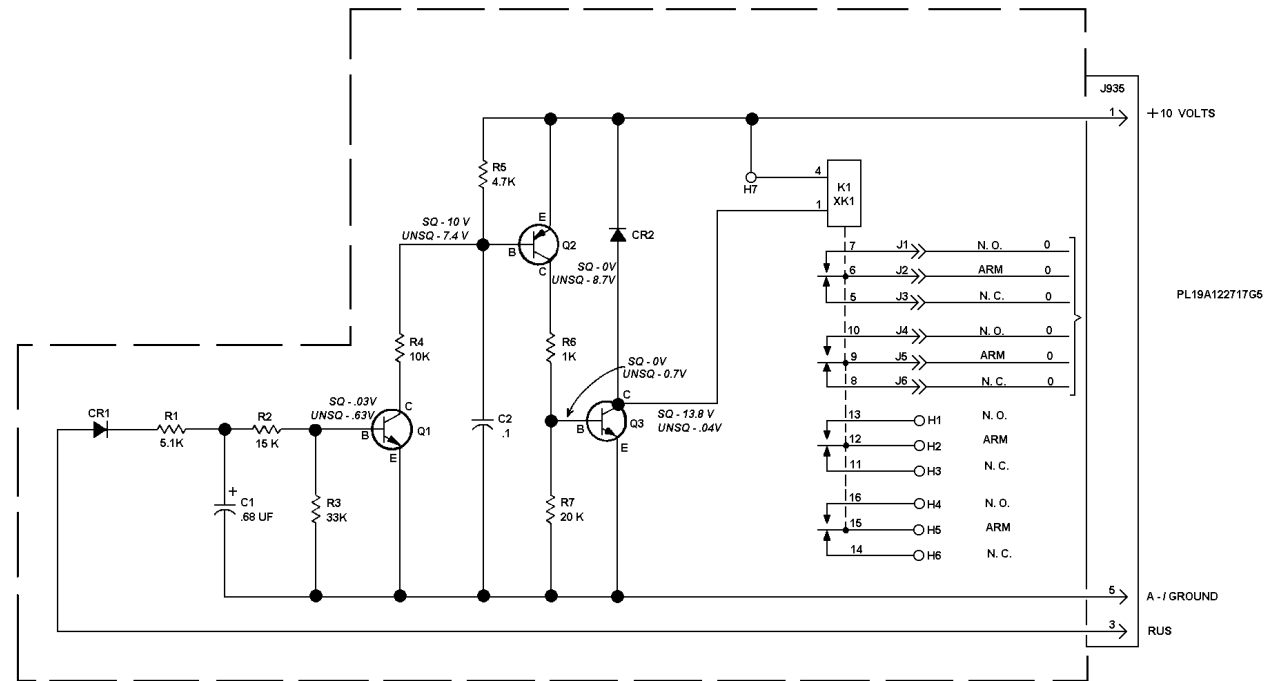

SEE APPLICABLE PRODUCTION CHANGE SHEETS IN INSTRUCTION BOOK SECTION DEALING WITH THIS UNIT, FOR DESCRIPTION OF CHANGES UNDER EACH REVISION LETTER.

THIS ELEM DIAG APPLIES TO	
MODEL NO	REV LETTER
PL19C320913G1	A

ALL RESISTORS ARE 1/4 WATT UNLESS OTHERWISE SPECIFIED AND RESISTOR VALUES IN OHMS UNLESS FOLLOWED BY K = 1000 OHMS OR MEG = 1,000,000 OHMS. CAPACITOR VALUES IN PICO FARADS (EQUAL TO MICROFARADS) UNLESS FOLLOWED BY UF = MICROFARADS. INDUCTANCE VALUES IN MICROHENRYS UNLESS FOLLOWED BY MH = MILLIHENRYS OR H = HENRYS.

IN ORDER TO RETAIN RATED EQUIPMENT PERFORMANCE, REPLACEMENT OF ANY SERVICE PART SHOULD BE MADE ONLY WITH A COMPONENT HAVING THE SPECIFICATIONS SHOWN ON THE PARTS LIST FOR THAT PART.

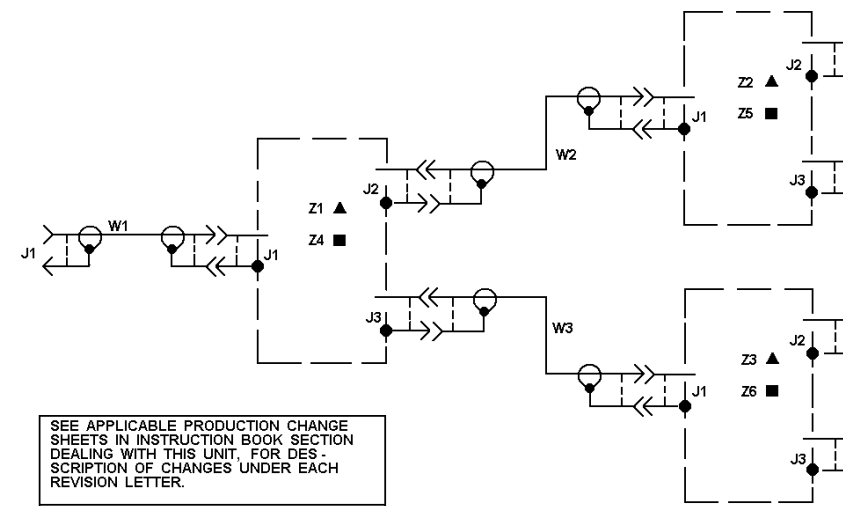

▲ 425 - 174 MHZ
■ 450 - 512 MHZ

IN ORDER TO RETAIN RATED EQUIPMENT PERFORMANCE, REPLACEMENT OF ANY SERVICE PART SHOULD BE MADE ONLY WITH A COMPONENT HAVING THE SPECIFICATIONS SHOWN ON THE PARTS LIST FOR THAT PART.

SEE APPLICABLE PRODUCTION CHANGE SHEETS IN INSTRUCTION BOOK SECTION DEALING WITH THIS UNIT, FOR DESCRIPTION OF CHANGES UNDER EACH REVISION LETTER.

THIS ELEM DIAG APPLIES TO	
MODEL NO	REV LETTER
19C321150G1	
19C321150G2	

**SQUELCH OPERATED RELAY
19C320913G1**

(19C320915, Rev. 3)

**ANTENNA MATCHING UNITS
19C321150G1 & G2**

(19B226529, Rev. 1)

**AUXILIARY RECEIVER 10 - VOLT REGULATOR BOARD
19C320918G1**

SYMBOL	PART NUMBER	DESCRIPTION
		----- CAPACITORS -----
C801	344A4195P471250	Electrolytic: 470 µF ±20%, 25 VDCW; sim to United Chemicon 9ME or Nichicon VX series.
C803	5496267P28	Tantalum: 0.47 µF ±20%, 35 VDCW; sim to Sprague Type 150D.
C804	19A115880P10	Electrolytic: 200 µF +150-10%, 18 VDCW; sim to Mallory Type TTX.
		----- DIODES -----
CR801 and CR802	162B3011P0002	Light Emitting Diode: Red; sim to GE 22L-2.
		----- FUSES -----
F801	1R16P3	Quick blowing: 1 amp at 250 v; sim to Littelfuse 312001 or Bussmann AGC-1.
F802	1R16P6	Quick blowing: 3 amp at 250 v; sim to Littelfuse 312003 or Bussmann AGC-3.
		----- INDUCTORS -----
L801	19A115894P1	Audio freq: 1.0 mh inductance, 0.35 ohms DC res.
		----- TRANSISTORS -----
Q801	19A116375P1	Silicon, PNP.
Q802	19A115768P1	Silicon, PNP: sim to 2N3702.
		----- RESISTORS -----
R801 and R802	19A700106P63	Composition: 1K ohms ±5%, 1/4 w.
R803	19A700106P61	Composition: 820 ohms ±5%, 1/4 w.
R804	19A700106P83	Composition: 6.8K ohms ±5%, 1/4 w.
		----- SWITCHES -----
S801	19B209261P9	Slide switch: DPST, 2 poles, 2 positions, 0.5 amps VDC or 3 amps VAC at 125 volts; sim to Switchcraft 11A1244.
S802	19B209261P13	Slide: DPDT, sim. to Switchcraft 11B-1017B.
		--- INTEGRATED CIRCUITS ---
U801	19D416564G13 19D416564G3	Regulator, 10 - volt. In Rev. A and earlier. Regulator, 10 - volt.
		----- FUSE SOCKETS -----
XF801 and XF802	19A116688P1	Fuse clip: sim to Littelfuse, Inc. 10271. (Quantity 2.) (XF802 added by Rev. A).

* COMPONENTS, ADDED, DELETED OR CHANGED BY PRODUCTION CHANGES.

SYMBOL	PART NUMBER	DESCRIPTION
		----- MISCELLANEOUS -----
	19C320909P1	Printed wire board.
	19A116688P1	Fuse clip: sim to Littelfuse, Inc. 102071.
	7118719P10	Clip, spring tension: sim to Prestole E-50019-003.
	19B800808P153	Rivet, tubular.
	19A116659P11	Connector, printed wiring: 7 contacts rated at 5 amps; sim to Molex 09-64-1071.
	19A116659P13	Connector, printed wiring: 4 contacts rated at 5 amps; sim to Molex 09-64-1041.
	19A130082P1	Heat sink.
	19B800608P154	Rivet, tubular.
	N80P9006B6	Screw, Machine: Pan Head; 4-40 x 3/8".
	N404P11B6	Lockwasher, internal tooth, No. 4.
	7141225P2	Nut, Hex: 4-40.
	19A705469P1	Insulator Plate, TO- 220.

PRODUCTION CHANGES

Changes in the equipment to improve performance or to simplify circuits are identified by a "Revision Letter", which is stamped after the model number of the unit. The revision stamped on the unit includes all previous revisions. Refer to the Parts List for descriptions of parts affected by these revisions.

REV. A 10-VOLT REGULATOR BOARD 19C320918G1
To correct distortion at the 600 ohm output. Changed F801 fuse and added XF802 fuse and socket.

REV. B 10-VOLT REGULATOR BOARD 19C320918G1
To improve transmitter operation. Changed U801.

**AUXILIARY RECEIVER CHASSIS
19D417546G7 LOW, HIGH, UHF BAND
19D417546G8 800 BAND**

SYMBOL	PART NUMBER	DESCRIPTION
		----- CABLES -----
W2402	5491689P105	Cable, RF: approx 14 inches long, 350 VRMS, 500 VDC operating voltage. (Used in G7)
W2403	19A138930G2	Cable, RF: approx 21 inches long, includes J2402 and P2403.
W2404	19D417548G6	Auxiliary Receiver, harness assembly.
		----- JACKS -----
J2401	19C851881P1	Cap Assembly.
		----- PLUGS -----
P2401	19A116659P21 19A116781P5	Includes: Contact, electrical: wire range No. 18 - 24 AWG, sim to Molex 08-50-0108. (Terminal 7)
	19A118781P6	Contact, electrical: wire range No. 22 - 26 AWG; sim to Molex 08-50-0108. (Terminals 1-6, 11).
	19B209519P1	Polarity tab. (Terminal 8)
P2402	19A116659P25 19A116781P5	Includes: Contact, electrical: wire range No. 18 - 24 AWG, sim to Molex 08-50-0108. (Terminal 7)
	19A116781P6	Contact, electrical: wire range No. 22 - 26 AWG; sim to Molex 08-50-0108. (Terminals 1-6, 11).
	19B209519P1	Polarity tab. (Terminal 8)
P2403		Part of W2403 and W2403.
		----- RESISTORS -----
R2401	5496870P31	Variable, carbon film; 10K ohms ±20%, sim to Mallory LC (25K).
		----- MISCELLANEOUS -----
	19A134357P8	Cable, RF: approx 21 inches long. (Used in G2)
	19A115938P12	Connector, coaxial: (BNC Series); sim to Amphenol 31-342. (Used in G2)
	19A116781P3	Contacts: 16-20 AWG; sim to Molex 08-50-0105 (Qty. of 10).
	19A116781P4	Contacts: 22-26 AWG; sim to Molex 08-50-0107, Qty of 10.
	4035031P33	Wire strand.
	N80P13004B6	Screw, machine: Pan head; No. 6-32 x 1/4".
	N193P1208B6	Screw, tapping, #6-20 thread x 1/2".
	4032591P68	Pressure sensitive tape.
	19B201074P205	Tap screw, Phillips POZIDRIV: No. 4-40 x 5/16. (Used in G7)
	19A116781P3	Contacts: 16-20 AWG; sim to Molex 08-50-0105 (Qty of 10).
	19AS116781P4	Contacts: 22-26 AWG; sim to Molex 08-50-0107, Qty of 10.
	N80P9006B6	Screw, Machine: Pan Head; 4-40 x 3/8".
	N404P11B6	Lockwasher, internal tooth, No. 4.
	N403P13B6	Lockwasher, No. 6
	19A121676P2	Guide pin.
	19B226352G1	Label.
	N404P13B6	Lockwasher, internal tooth, No. 6.
	N80P13005B6	Machine screw, panhead: No. 6-32 x 5/16.

* COMPONENTS ADDED, DELETED OR CHANGED BY PRODUCTION CHANGES

SYMBOL	PART NUMBER	DESCRIPTION
		HARDWARE KIT 19A130031G5
		----- MISCELLANEOUS -----
	19A116773P108	Tap screw, Phillips POZIDRIV: No. 7-19 x 1/2.
	19A148393P307	Flat head screw.
	19B201074P304	Tap screw, Phillips POZIDRIV: No. 6-32 x 1/4.
	19B201074P306	Tap screw, Phillips POZIDRIV: No. 6-32 x 3/8.
	19B201074P310	Tap screw, Phillips POZIDRIV: No. 6-32 x 5/8.
	7147306P2	Insulator, bushing: No. 6, black pressed fiber: sim to H.H. Smith Inc. 2150.
	19B201074P305	Tap screw, Phillips POZIDRIV: No. 6-32 x 5/16.
	N404P13B6	Lockwasher, internal tooth: No. 6.
	N80P13005B6	Machine screw, panhead: No. 6-32 x 5/16.
	N80P9005B6	Machine screw, pan head, steel, No. 4-40unc x 5/16".
	N404P11B6	Lockwasher, internal tooth, No. 4.
	7141225P2	Nut, Hex: 4-40.
	N80P21005B6	Machine screw: 1/4 (.250) - 20 x .312.
	N80P13009B6	Machine screw.
	19A701883P11	Clip loop.
	19A148393P306	Tap screw, TORZ DRIVE: No. 632 x 3/8.
		ASSOCIATED ITEMS CABLE ASSEMBLY 19B227832G1
		----- JACKS AND RECEPTACLES -----
J204		Connector. Includes printed wire connector (19A116859P14) and electrical contact (19A116781P6).
P2404	19A116659P55	Connector, printed wiring: 3 contacts rated at 5 amps; sim to Molex 09-05-1031.
		MECHANICAL PARTS (SEE RC2752)
1	19B209480P1	Slide drawer.
2	19C320899G1	Can.
3	19B226035G2	Support.
4	19C320664P1	Frame. (Used in G7)
5	19C320664P3	Frame. (Used in G8).
6	19A701863P11	Clip, Loop. (Used in G7).
7	19A121676P1	Guide pin.
8	19B201074P204	Tap screw, Phillips POZIDRIV No. 4-40 x 1/4 (Secures J2402).
9	7115130P9	Lockwasher, internal tooth: No. 3/8.
10	7165075P2	Hex nut, brass: thd. size No. 3/8-32.
11	19B226216G1	Support.
12	19C336435P1	Knob.
13	19B234589P1	Pawl.
14	19A115161P2	Sleeving.
15	N402P39B6	Flatwasher: No. 10.
16	4035664P8	Nut, self locking.
17	19B209519P1	Polarity tab. (Used in G6).
18	19B226035G1	Support.
19	19A115874P1	Catch, friction.
20	N193P1208C6	Tap screw, Phillips head: No. 6-20 x 1/2.
21	5493361P8	Washer, spring tension.
22	19B226216G2	Support.
23	19C320917G1	Support.
24	19B226105G2	Support.
25	7141225P3	Hex Nut: No. 6-32.
26	N404P13C6	Lockwasher, internal tooth: No. 6.
	19C320673G2	Cover, RF receiver. (Not shown).

**AUXILIARY RECEIVER SYSTEM BOARD
19D429764G1**

SYMBOL	PART NUMBER	DESCRIPTION
----- CAPACITORS -----		
C901	5496267P2	Tantalum: 47 μ F \pm 20%, 6 VDCW; sim to Sprague Type 150D.
C902	19A115680P7	Electrolytic: 100 μ F +150-10%, 15 VDCW; sim to Mallory Type TTX.
C903	5496267P14	Tantalum: 15 μ F \pm 20%, 20 VDCW; sim to Sprague Type 150D.
C904	19A116080P107	Polyester: 0.1 μ F \pm 10%, 50 VDCW.
C905	19A115680P7	Electrolytic: 100 μ F +150-10%, 15 VDCW; sim to Mallory Type TTX.
C906	19A701371P11	Polyester: 0.047 μ F \pm 5%, 50 VDCW.
C907	19A701371P9	Polyester: 0.022 μ F \pm 5%, 50 VDCW.
C908	19A701371P8	Polyester: 0.015 μ F \pm 5%, 50 VDCW.
C909 and C910	19A116080P109	Polyester: 0.22 μ F \pm 10%, 50 VDCW.
C911	5494481P111	Ceramic disc: 1000 pF \pm 20%, 1000 VDCW; sim to RMC Type JF Discap.
C912	5496267P14	Tantalum: 15 μ F \pm 20%, 20 VDCW; sim to Sprague Type 150D.
C913 and C914	19A700004P11	Metallized Polyester: 0.1 μ F \pm 10%, 63 VDCW.
C915	5494481P111	Ceramic disc: 1000 pF \pm 20%, 1000 VDCW; sim to RMC Type JF Discap.
C916	19A116080P107	Polyester: 0.1 μ F \pm 10%, 50 VDCW.
C917	5496267P10	Tantalum: 22 μ F \pm 20%, 15 VDCW; sim to Sprague Type 150D.
C918	19A116080P107	Polyester: 0.1 μ F \pm 10%, 50 VDCW.
C919	19A116080P106	Polyester: 0.068 μ F \pm 10%, 50 VDCW.
C920 and C921	5494481P1	Ceramic disc: 150 pF \pm 20%, 1000 VDCW; sim to RMC Type JF Discap.
----- DIODES -----		
CR901	19A115250P1	Silicon, fast recovery, 225 mA, 50 PIV.
CR902 and CR903	T324ADP1061	Silicon: 800 PRV, 1000 mA max; sim to 1N4006.
CR904 thru CR906	19A115250P1	Silicon, fast recovery, 225 mA, 50 PIV.
----- JACKS -----		
J901	19A116659P11	Connector, printed wiring: 7 contacts rated at 5 amps; sim to Molex 09-64-1071. (Quantity 2).
J903 and J904	19A116659P12	Connector, printed wiring: 6 contacts rated at 5 amps; sim to Molex 09-64-1061. Connector. Includes:
J905 thru J910	19A116659P1	Connector, printed wiring: 3 contacts rated at 5 amps; sim to Molex 09-52-3032.
J936	19A116659P4	Connector, printed wiring: 6 contacts rated at 5 amps; sim to Molex 09-52-3062.
J905 thru J910	4033513P4	Contact, electrical: sim to Bead Chain L93-3.
J936	4033513P4	Contact, electrical: sim to Bead Chain L93-3.
----- PLUGS -----		
P902	19A701785P1	Contact, electrical: sim to Molex 08-50-0404.
P906 thru P909	19A701785P1	Contact, electrical: sim to Molex 08-50-0404.

SYMBOL	PART NUMBER	DESCRIPTION
----- TRANSISTORS -----		
Q901 and Q902	19A116774P1	Silicon, NPN; sim to Type 2N5210.
Q903	19A700023P1	Silicon, NPN: sim to 2N3904.
Q904	19A116774P1	Silicon, NPN; sim to Type 2N5210.
Q905 and Q906	19A700023P1	Silicon, NPN: sim to 2N3904.
Q907	19A116774P1	Silicon, NPN; sim to Type 2N5210.
Q908	19A115300P4	Silicon, NPN.
Q909	19A700023P1	Silicon, NPN: sim to 2N3904.
----- RESISTORS -----		
R901 and R902	19A700106P99	Composition: 33K ohms \pm 5%, 1/4 w.
R903	19A700106P111	Composition: 100K ohms \pm 5%, 1/4 w.
R904	3R152P204J	Composition: 200K ohms \pm 5%, 1/4 w.
R905	19A700106P87	Composition: 10K ohms \pm 5%, 1/4 w.
R906	19A700106P91	Composition: 15K ohms \pm 5%, 1/4 w.
R907	19A700106P101	Composition: 39K ohms \pm 5%, 1/4 w.
R908	3R152P154J	Composition: 150K ohms \pm 5%, 1/4 w.
R909	3R152P512J	Composition: 5.1K ohms \pm 5%, 1/4 w.
R910	19A700106P51	Composition: 330 ohms \pm 5%, 1/4 w.
R911	19A700106P63	Composition: 1K ohms \pm 5%, 1/4 w.
R912	19A700106P91	Composition: 15K ohms \pm 5%, 1/4 w.
R913	3R152P203J	Composition: 20K ohms \pm 5%, 1/4 w.
R915	19A700106P87	Composition: 10K ohms \pm 5%, 1/4 w.
R917	19A700106P39	Composition: 100 ohms \pm 5%, 1/4 w.
R918	19A700106P87	Composition: 10K ohms \pm 5%, 1/4 w.
R921	19A700106P87	Composition: 10K ohms \pm 5%, 1/4 w.
R922	19A700106P91	Composition: 15K ohms \pm 5%, 1/4 w.
R924	19A700106P109	Composition: 82K ohms \pm 5%, 1/4 w.
R925	19A700106P97	Composition: 27K ohms \pm 5%, 1/4 w.
R926	3R152P242J	Composition: 2.4K ohms \pm 5%, 1/4 w.
R927	3R152P300J	Composition: 30 ohms \pm 5%, 1/4 w.
R928	19A700106P17	Composition: 12 ohms \pm 5%, 1/4 w.
R929	19A700106P71	Composition: 2.2K ohms \pm 5%, 1/4 w.
R930	19B209358P106	Variable: 10K ohms \pm 5%, 1/4 w; sim to CTS X-201.
R931	3R77P621J	Composition: 620 ohms \pm 5%, 1/4 w.
R932	19A700106P91	Composition: 15K ohms \pm 5%, 1/4 w.
R933	19A700106P111	Composition: 100K ohms \pm 5%, 1/4 w.
R935	19A700106P75	Composition: 3.3K ohms \pm 5%, 1/4 w.
R936	19B209358P116	Variable carbon film: approx 26 to 2.5K ohms \pm 10%, 0.2w; sim to Stackpole R11-4442.
R937	19A700106P89	Composition: 12K ohms \pm 5%, 1/4 w.
R938	19A700106P109	Composition: 82K ohms \pm 5%, 1/4 w.
R940	3R152P242J	Composition: 2.4K ohms \pm 5%, 1/4 w.
R941	19A700106P57	Composition: 560 ohms \pm 5%, 1/4 w.
R942	19A700106P87	Composition: 10K ohms \pm 5%, 1/4 w.
----- TRANSFORMERS -----		
T901	19A116736P1	Audio freq: 300 to 6000 Hz, Pri: 30 ohms \pm 15% DC res, Sec No. 1 & 2: 15 ohms \pm 15%.
----- VOLTAGE REGULATORS -----		
VR901	19A116325P4	Zener: 5 w, 12 v; sim to Type 1N5349.

SYMBOL	PART NUMBER	DESCRIPTION
----- MISCELLANEOUS -----		
	19A701785P1	Contact, electrical: sim to Molex 08-50-0404.
	19A116659P1	Connector, printed wiring: 3 contacts rated at 5 amps; sim to Molex 09-52-3032.
	19A116659P4	Connector, printed wiring: 6 contacts rated at 5 amps; sim to Molex 09-52-3062.
	5491541P302	Spacer.
	19B219761P3	Jumper.
	19A116659P11	Connector, printed wiring: 7 contacts rated at 5 amps; sim to Molex 09-64-1071.
	19A116659P12	Connector, printed wiring: 6 contacts rated at 5 amps; sim to Molex 09-64-1061.
	19A701332P4	Insulator, washer: nylon.
	N80P13006B6	Machine screw: Pan head, Phillips; No. 8-32x3/8".

PRODUCTION CHANGES

Changes in the equipment to improve performance or to simplify circuits are identified by a "Revision Letter", which is stamped after the model number of the unit. The revision stamped on the unit includes all previous revisions. Refer to the Parts List for descriptions of parts affected by these revisions.

**REV. A AUXILIARY RECEIVER SYSTEM BOARD
19D429764G1**
To improve performance. Changed R910 and R938.

**REV. B AUXILIARY RECEIVER SYSTEM BOARD
19D429764G1**
To eliminate dipping in the audio output. Changed R910.

**REV. C AUXILIARY RECEIVER SYSTEM BOARD
19D429764G1**
To reduce distortion levels at low audio frequencies: R910, R927, R938, and R941 were changed.

**REV. D AUXILIARY RECEIVER SYSTEM BOARD
19D429764G1**
To improve the audio frequency response of the receiver: C910, C913 and C914 were changed.

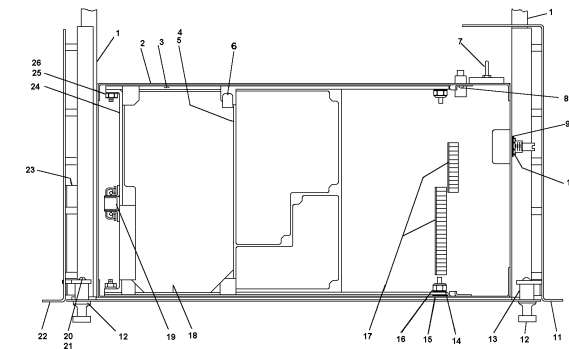

* COMPONENTS ADDED, DELETED OR CHANGED BY PRODUCTION CHANGES

CHANNEL GUARD FILTER BOARD
19C320627G1

SYMBOL	PART NUMBER	DESCRIPTION
----- CAPACITORS -----		
C1	19C300075P47001G	Polyester: .047 μ F \pm 2%, 100 VDCW; sim to GE Type 61F.
C2	19C300075P10002G	Polyester: .1 μ F \pm 2%, 100 VDCW; sim to GE Type 61F.
C3	19C300075P47001G	Polyester: .047 μ F \pm 2%, 100 VDCW; sim to GE Type 61F.
C4	19C300075P47001G	Polyester: .01 μ F \pm 2%, 100 VDCW; sim to GE Type 61F.
C5	5496267P14	Tantalum: 15 μ F \pm 20%, 20 VDCW; sim to Sprague Type 150D.
C6 and C7	19C300075P47001G	Polyester: .047 μ F \pm 2%, 100 VDCW; sim to GE Type 61F.
C8	T644ACP333K	Polyester: .033 μ F \pm 10%, 50 VDCW.
C9	19C300075P47001G	Polyester: .047 μ F \pm 2%, 100 VDCW; sim to GE Type 61F.
----- JACKS -----		
J1 and J2	19A700102P1	Printed wire: 3 contacts rated at 5 amps; sim to Molex 09-52-3031.
----- TRANSISTORS -----		
Q1	19A116774P1	Silicon, NPN; sim to Type 2N5210.
Q2 and Q3	19A700022P1	Silicon, PNP; sim to 2N3906.
Q4	19A116774P1	Silicon, NPN; sim to Type 2N5210.
----- RESISTORS -----		
R1	19A701250P325	Metal film: 17.8K ohms \pm 1%, 1/4 w.
R2	19A701250P293	Metal film: 90.0K ohms \pm 1%, 1/4 w.
R3	19A701250P325	Metal film: 17.8K ohms \pm 1%, 1/4 w.
R4	19A701250P317	Metal film: 14.7K ohms \pm 1%, 1/4 w.
R5	19A701250P333	Metal film: 2.15K ohms \pm 1%, 250VDCW, 1/4w.
R6	19A701250P253	Metal film: 3.48K ohms \pm 1%, 1/4 w.
R7	19A700106P87	Composition: 10K ohms \pm 5%, 1/4w.
R8	19A701250P221	Metal film: 1620 ohms \pm 1%, 250VDCW, 1/4w.
R9	19A701250P201	Metal film: 1K ohms \pm 1%, 250VDCW, 1/4w.
R10	3R152P751J	Composition: 750 ohms \pm 5%, 1/4w.
R11	19A701250P412	Metal film: 130 K ohms \pm 1%, 1/4 w.
R12	19A701250P233	Metal film: 2.15K ohms \pm 1%, 1/4 w.
R13	19A700106P87	Composition: 10K ohms \pm 5%, 1/4w.
R14	19A701250P265	Metal film: 4.6K ohms \pm 1%, 1/4 w.
R15	19A701250P132	Metal film: 210 ohms \pm 1%, 250VDCW, 1/4w.
R16	19A701250P419	Metal film: 154K ohms \pm 1%, 1/4 w.

★ COMPONENTS ADDED, DELETED OR CHANGED BY PRODUCTION CHANGES

TONE NOTCH FILTER/LINE RESPONSE
COMPENSATOR BOARD
19C328328G1

SYMBOL	PART NUMBER	DESCRIPTION
----- INTEGRATED CIRCUITS -----		
AR1	19A134511P1	Linear: Quad Op Amp; sim to LM224J.
----- CAPACITORS -----		
C1	19C307114P6801G	Polystyrene: 6800 pF \pm 2%, 100 VDCW, temp coef -120+30 PPM.
C2	19C307114P1002G	Polystyrene: 10,000 pF \pm 2%, 100 VDCW, temp coef -120+30 PPM.
C3	19C307114P6801G	Polystyrene: 6800 pF \pm 2%, 100 VDCW, temp coef -120+30 PPM.
C4	19A134202P15	Tantalum: 6.8 μ F \pm 20%, 35 VDCW.
C5	19A134202P6	Tantalum: 22 μ F \pm 20%, 15 VDCW.
C6 and C7	19A701371P5	Polyester: 4700 pF \pm 5%, 50VDCW.
C8	19A116080P107	Polyester: 0.1 μ F \pm 10%, 50 VDCW.
C9 and C10	19A701371P11	Polyester: 0.047 μ F \pm 5%, 50VDCW.
C11	19A116080P109	Polyester: 0.22 μ F \pm 10%, 50 VDCW.
C12	19A134202P6	Tantalum: 22 μ F \pm 20%, 15 VDCW.
C13	19A701371P3	Polyester: .0022 μ F.
C14	19A116080P207	Polyester: 0.1 μ F \pm 5%, 50VDCW.
C15	19A134202P6	Tantalum: 22 μ F \pm 20%, 15 VDCW.
----- INDUCTORS -----		
L1		Coil. 19B205354G5
----- MISCELLANEOUS -----		
	19C300764P12	Clip, spring tension.
	5495789P3	Tuning slug.
	19A110475P3	Washer.
L2	19B205354G4	Coil.
L3	19B205354G5	Coil.
----- RESISTORS -----		
R1 and R2	3R152P202J	Composition: 2K ohms \pm 5%, 1/4 w.
R3	19A701250P447	Metal film: 301K ohms \pm 1%, 1/4 w.
R4	19A701250P366	Metal film: 47.5K ohms \pm 1%, 1/4 w.
R5	19A701250P280	Metal film: 6.65K ohms \pm 1%, 1/4 w.
R6	19A701250P285	Metal film: 7.5K ohms \pm 1%, 250VDCW, 1/4w.
R7 and R8	19A701250P318	Metal film: 15K ohms \pm 1%, 1/4 w.
R9 and R10	19A701250P347	Metal film: 30.1K ohms \pm 1%, 250VDCW, 1/4w.
R11	19A701250P330	Metal film: 20K ohms \pm 1%, 1/4 w.
R12	19A116559P112	Variable cermet: 500K ohms \pm 20%, .18 w; sim to CTS Series 360.
R13	19A700106P87	Composition: 10K ohms \pm 5%, 1/4 w.
R14 and R15	19A701250P324	Metal film: 17.4K ohms \pm 1%, 1/4 w.
R16 and R17	19A701250P353	Metal film: 34.8K ohms \pm 1%, 250VDCW, 1/4w.
R18	19A701250P330	Metal film: 20K ohms \pm 1%, 1/4 w.
R19	19A116559P112	Variable cermet: 500K ohms \pm 20%, .18 w; sim to CTS Series 360.
R20	19A700106P87	Composition: 10K ohms \pm 5%, 1/4 w.

★ COMPONENTS ADDED, DELETED OR CHANGED BY PRODUCTION CHANGES

SYMBOL	PART NUMBER	DESCRIPTION
R21 thru R23	19A701250P305	Metal film: 11K ohms \pm 1%, 250VDCW, 1/4w.
R24	19A701250P353	Metal film: 34.8K ohms \pm 1%, 250VDCW, 1/4w.
R25 and R26	19A700106P87	Composition: 10K ohms \pm 5%, 1/4 w.
R27 and R28	19A701250P372	Metal film: 54.9K ohms \pm 1%, 1/4 w.
R29	19A700106P51	Composition: 330 ohms \pm 5%, 1/4 w.
	19A702402P2	Contact, electrical; sim to AMP 42827-2.
	19C328328G4	Tone filter.
	N80P13005B6	Machine screw, panhead: No. 6-32 x 5/16.
	N404P13B6	Lockwasher, internal tooth: No. 6.

**TONE NOTCH FILTER BOARD
19C328328G3**

SYMBOL	PART NUMBER	DESCRIPTION
		----- CAPACITORS -----
C1	19C307114P6801G	Polystyrene: 6800 pF ±2%, 100 VDCW, temp coef -120+30 PPM.
C2	19C307114P1002G	Polystyrene: 10,000 pF ±2%, 100 VDCW, temp coef -120+30 PPM.
C3	19C307114P6801G	Polystyrene: 6800 pF ±2%, 100 VDCW, temp coef -120+30 PPM.
C4	19A134202P15	Tantalum: 6.8 μF ±20%, 35 VDCW.
		----- INDUCTORS -----
L1		Coil 19B205354G5
		----- MISCELLANEOUS -----
	19C300784P12	Clip, spring tension.
	5495789P3	Tuning slug.
	19A110475P3	Washer.
L2	19B205354G4	Coil.
L3	19B205354G5	Coil.
		----- RESISTORS -----
R1 and R2	3R152P202J	Composition: 2K ohms ± 5%, 1/4w.
		----- MISCELLANEOUS -----
	19A702402P2	Contact, electrical; sim to AMP 42B27-2.
	19C328328G6	Filter, tone.
	N80P13005B6	Machine screw, panhead: No. 6-32x5/16.
	N404P13B6	Lockwasher, internal tooth: No. 6.

★ COMPONENTS ADDED, DELETED OR CHANGED BY PRODUCTION CHANGES

**AUXILIARY RECEIVER SOR BOARD
19C320913G1**

SYMBOL	PART NUMBER	DESCRIPTION
		----- CAPACITORS -----
C1	5496267P29	Tantalum: 0.68 μF ±20%, 35 VDCW; sim to Sprague Type 150D.
C2	19A116080P107	Polyester: 0.1 μF ±10%, 50 VDCW.
		----- DIODES -----
CR1	19A115250P1	Silicon, fast recovery, 225 mA, 50 PIV.
CR2	T324ADP1041	Silicon: Rectifier; sim to 1N4004.
		----- JACKS -----
J1 thru J6	4033513P4	Contact, electrical: sim to Bead Chain L93-3.
		----- RELAYS -----
K1	19C300957P2	Enclosed: 185 ohms ± 10% coil res, 12v 1.5 w, 4 form C contacts; sim to Allied Control T154X-316.
		----- TRANSISTORS -----
Q1	19A700023P1	Silicon, NPN: sim to 2N3904.
Q2	19A700022P1	Silicon, PNP: sim to 2N3906.
Q3	19A115300P2	Silicon, NPN: sim to Type 2N3053.
		----- RESISTORS -----
R1	3R152P512J	Composition: 5.1K ohms ± 5%, 1/4w.
R2	19A7001106P91	Composition: 15K ohms ± 5%, 1/4w.
R3	19A7001106P99	Composition: 33K ohms ± 5%, 1/4w.
R4	19A7001106P87	Composition: 10K ohms ± 5%, 1/4w.
R5	19A7001106P79	Composition: 4.7K ohms ± 5%, 1/4w.
R6	19A7001106P63	Composition: 1K ohms ± 5%, 1/4w.
R7	3R152P203J	Composition: 20K ohms ± 5%, 1/4w.
		----- SOCKETS -----
XK1	5491595P7	Relay: 10 contacts; sim to Allied Control 30054-4.
		----- MISCELLANEOUS -----
	19A700102P1	Printed wire: 3 contacts rated at 5 amps; sim to Molex 09-52-3031.
	19A116659P7	Connector, printed wire: 4 contacts rated at 5 amps; sim to Molex 09-51-3041.
	5491595P9	Retainer: spring; sim to Allied Control 30040-2.
	19A701332P4	Insulator, washer: nylon.

★ COMPONENTS ADDED, DELETED OR CHANGED BY PRODUCTION CHANGES

PRODUCTION CHANGES

Changes in the equipment to improve performance or to simplify circuits are identified by a "Revision Letter" which is stamped after the model number of the unit. The revision stamped on the unit includes all previous revisions. Refer to the Parts list for descriptions of parts affected by these revisions.

REV. A AUXILIARY RECEIVER SOR BOARD 19C320913G1
To improve operation of the SOR Board, C1 was changed.

**ANTENNA MATCHING UNIT
19C321150G1 - G2**

SYMBOL	PART NUMBER	DESCRIPTION
		----- JACKS -----
J1		Part of W1.
		----- CABLES -----
W1	19A127854G7	Cable, RF: approx 5 1/2 inches long. (Includes J1).
W2 and W3	5491689P91	Cable, RF: approx 7 1/2 inches long.
Z1 thru Z3		POWER SEPARATOR (Used in G1). 19C317281G1
		----- CAPACITORS -----
C1 and C2	7489162P5	Silver mica: 9 pF ± 5%, 500 VDCW; sim to Sprague Type 118. (Used in G1).
C3	19A700105P11	Mica: 15 pF ± 5%, 500 VDCW. (Used in G1).
		----- TERMINALS -----
E1	19A116355P1	Terminal, stud: sim to USECO 1481-B.
		----- JACKS -----
J1, J2 and J3		Part of item 2. (Used in G1). Part of item 2. (Used in G1).
		----- INDUCTORS -----
L1		COIL ASSEMBLY (Used in G1). 19B216711G1
		----- RESISTORS -----
R1	19A700106P39	Composition: 100 ohms ± 5%, 1/4 w. (Used in G1).
L2	19B216738G1	Coil. (Used in G1).
		----- MISCELLANEOUS -----
	19B219366G1	Can. (Used in G1).
	19A127635P2	Plate. (Used in G1).
		----- NETWORKS -----
Z4		POWER SEPARATOR (Used in G2). 19C317352G1
		----- CAPACITORS -----
C1 and C2	5496218P35	Ceramic disc: 4.0 pF ± 0.25 pF, 500 VDCW, temp coef 0 PPM. (Used in G1).
C3	5496218P34	Ceramic disc: 3.0 pF ± 0.25 pF, 500 VDCW, temp coef 0 PPM. (Used in G1).
		----- TERMINALS -----
E1	19A116355P1	Terminal, stud: sim to USECO 1481-B. (Used in G1).
		----- JACKS -----
J1 thru J3		Jack, phono: coaxial.

★ COMPONENTS ADDED, DELETED OR CHANGED BY PRODUCTION CHANGES

SYMBOL	PART NUMBER	DESCRIPTION
		----- INDUCTORS -----
L1		COIL ASSEMBLY. 19B216827G1
		----- RESISTORS -----
R1	19A700113P39	Composition: 100 ohms ± 5%, 1/2 w. (Used in G1).
L2	19B216829G1	Coil. (Used in G1).
		----- MISCELLANEOUS -----
	19B216829P4	Coil. (Used in G1).
	N80P5002B6	Machine screw. (Used in G1).
	N404P8B6	Lockwasher. (Used in G1).
Z5 and Z6	19C317352G1	Power Separator. (Used in G2).
		----- MISCELLANEOUS -----
	19A130249G1	Panel.
	N80P9006B6	Screw, Machine: Pan Head; 4-40 x 3/8".
	7141225P2	Nut, Hex: 4-40.
	N402P35B6	Washer, plain.
	N404P11B6	Lockwasher, internal tooth, No. 4.

**AUXILIARY RECEIVER POWER SUPPLY
19C311855G1**

SYMBOL	PART NUMBER	DESCRIPTION
----- CAPACITORS -----		
C501	7476442P23	Electrolytic, twist prong; 200 μ F \pm 10 +250%, 50 VDCW.
C502	344A4195P471250	Capacitor, electrical, AX LD.
C503	19A116080P107	Polyester: 0.1 μ F \pm 10%, 50 VDCW.
----- DIODES -----		
CR501 thru CR504	T324ADP1041	Silicon; Rectifier; sim to 1N4004.
----- FUSES -----		
F501	19B800912P14	Fuses SB, 500MA250.
----- PLUGS -----		
P502 and P503	4036634P1	Contact, electrical; sim to AMP 42428-2.
----- TRANSISTORS -----		
Q501	19A116742P1	Silicon, NPN; sim to Type 2N6103.
----- RESISTORS -----		
R501	19A700106P43	Composition: 150 ohms \pm 5%, 1/4 w.
----- TRANSFORMERS -----		
T501	5493743P1	Power, step down: Pri: 117 v, 50/60 Sec 1: 12.6 v 3%, 2 amps.
----- VOLTAGE REGULATORS -----		
VR501	19A115528P6	Silicon, Zener.
----- CABLES -----		
W501	19A134567P1	Power, 3 wire, 13 amps at 125 VAC, approx. 6 ft. long.
----- FUSE SOCKETS -----		
XF501	19B209005P1	Fuseholder: 15 amps at 250 v; sim to Littelfuse 342012.
----- MISCELLANEOUS -----		
2	775500P25	Phen: 7 insulated, 2 grounded terminals.
4	19A702464P4	Bushing, strain relief.
5	19C311851G1	Chassis.
16	19A700068P1	Insulator, bushing.
17	19A705469P1	Insulator plate, TO-220.
18	775500P44	Phenolic: 1 insulated, 1 ground.
19	7162441P118	Insulation sleeving, electrical.
21	N80P9006B6	Screw, Machine: Pan Head; 4- 40 x 3/8".
22	N404P11B6	Lockwasher, Internal tooth No. 4.
23	7141225P2	Nut, Hex: 4- 40.
24	7141225P3	Hex Nut: No. 6- 32.
25	N404P13B6	Lockwasher, Internal tooth No. 6.
26	19C301208P7	Insulation sleeving, electrical: 3/8 inch.
27	19C301208P9	Insulation sleeving, electrical.

★ COMPONENTS ADDED, DELETED OR CHANGED BY PRODUCTION CHANGES

PRODUCTION CHANGES

Changes in the equipment to improve performance or to simplify circuits are identified by a "Revision Letter", which is stamped after the model number of the unit. The revision stamped on the unit includes all previous revisions. Refer to the Parts list for descriptions of parts affected by these revisions.

**REV. A AUXILIARY RECEIVER POWER SUPPLY
19C311855G1**

To comply with OSHA safety standards, W501 was changed.

**REV. B AUXILIARY RECEIVER POWER SUPPLY
19C311855G1**

To improve regulation, C501, F501, and R501 were changed and C502, C503, Q501, and VR501 were added.

**REV. C AUXILIARY RECEIVER POWER SUPPLY
19C311855G1**

To improve performance, Q501 and R501 were changed.

**LINE RESPONSE COMPENSATOR BOARD
19C328328G2**

SYMBOL	PART NUMBER	DESCRIPTION
----- INTEGRATED CIRCUITS -----		
AR1	19A134511P1	Linear: Quad Op Amp; sim to LM224J
----- CAPACITORS -----		
C5	19A134202P6	Tantalum: 22 μ F \pm 20%, 15 VDCW.
C6 and C7	19A701371P5	Polyester: 4700pF \pm 5%, 50 VDCW.
C8	19A116080P107	Polyester: 0.1 μ F \pm 10%, 50 VDCW.
C9 and C10	19A701371P11	Polyester: 0.047 μ F \pm 5%, 50 VDCW.
C11	19A118080P109	Polyester: 0.22 μ F \pm 10%, 50 VDCW.
C12	19A134202P6	Tantalum: 22 μ F \pm 20%, 15 VDCW.
C13	19A701371P3	Polyester: .0022 μ F
C14	19A116080P207	Polyester: 0.1 μ F \pm 5%, 50 VDCW.
C15	19A134202P6	Tantalum: 22 μ F \pm 20%, 15 VDCW.
----- RESISTORS -----		
R3	19A701250P447	Metal film: 301K ohms \pm 1%, 1/4 w.
R4	19A701250P366	Metal film: 47.5K ohms \pm 1%, 1/4 w.
R5	19A701250P280	Metal film: 6.65K ohms \pm 1%, 1/4 w.
R6	19A701250P285	Metal film: 7.5K ohms \pm 1%, 250VDCW, 1/4w.
R7 and R8	19A701250P318	Metal film: 15K ohms \pm 1%, 1/4 w.
R9 and R10	19A701250P347	Metal film: 30.1K ohms \pm 1%, 250VDCW, 1/4w.
R11	19A701250P330	Metal film: 20K ohms \pm 1%, 1/4w.
R12	19A116559P112	Variable cermet: 500K ohms \pm 20%, .18w. sim to CTS Series 360.
R13	19A700106P87	Composition: 10K ohms \pm 5%, 1/4w.
R14 and R15	19A701250P324	Metal film: 17.4K ohms \pm 1%, 1/4w.
R16 and R17	19A701250P353	Metal film: 34.8K ohms \pm 1%, 250VDCW, 1/4w.
R18	19A701250P330	Metal film: 20K ohms \pm 1%, 1/4w.
R19	19A116559P112	Variable cermet: 500K ohms \pm 20%, .18w; sim to CTS Series 360.
R20	19A700106P87	Composition: 10K ohms \pm 5%, 1/4w.
R21 thru R23	19A701250P305	Metal film: 11Kohms \pm 1%, 250VDCW, 1/4w.
R24	19A701250P353	Metal film: 34.8K ohms \pm 1%, 250VDCW, 1/4w.
R25 and R26	19A700106P87	Composition: 10K ohms \pm 5%, 1/4w.
R27 and R28	19A701250P372	Metal film: 54.9K ohms \pm 1%, 1/4w.
R29	19A700106P51	Composition: 330 ohms \pm 1%, 1/4w.
	19A702402P2	Contact, electrical; sim to AMP 42827-2.
	19C328328G5	Filter, tone.
	N80P13005B6	Machine screw, panhead: No. 6-32x5/16.
	N404P13B6	Lockwasher, Internal tooth: No. 6.

★ COMPONENTS ADDED, DELETED OR CHANGED BY PRODUCTION CHANGES

**AUXILIARY RECEIVER OVERLAY HARNESS
19B226307G1**

SYMBOL	PART NUMBER	DESCRIPTION
----- PLUGS -----		
P1		Connector includes 19C330656P1-SHELL and 19A115793P1-CONTACTS 19A143191G1
----- TERMINAL BOARDS -----		
TB1	19C301088P1	Terminal board: 3-Position.
----- MISCELLANEOUS -----		
	5496809P17	Contact, pin: female, brass; sim to Molex Products 1381-t.
	19B209288P2	Contact, male: 14-20 AWG; sim to Molex 02-09-2101.

★ COMPONENTS ADDED, DELETED OR CHANGED BY PRODUCTION CHANGES

AUXILIARY RECEIVER OVERLAY HARNESS (EACOM)
19B226307G2

AUXILIARY RECEIVER OVERLAY HARNESS
WITH CHANNEL GUARD MONITOR
19B226307G3

SYMBOL	PART NUMBER	DESCRIPTION
		----- PLUGS -----
P1	19A143101G1	Connector includes 19C330656P1-SHELL and 19A115793P1-CONTACTS
		----- MISCELLANEOUS -----
P16	19B209288P20	Shell: 12-Position; sim to Molex 03-09-1122
		----- TERMINAL BOARDS -----
TB1	19C301086P1	Terminal board: 3-Position
		----- MISCELLANEOUS -----
	19B209288P2	Contact, male: 14-20 AWG; sim to Molex 02-09-2101.
	19B209288P29	Contact, female: 22-30 AWG; sim to Molex 02-09-1141.
	19B209288P30	Contact, male: 22-30 AWG; sim to Molex 02-09-2141.

SYMBOL	PART NUMBER	DESCRIPTION
		----- PLUGS -----
P1	19A143191G1	Connector includes 19C330656P1-SHELL and 19A115793P1-CONTACTS.
		----- RESISTORS -----
R1	H212CRP310C	Deposited carbon: 10K ohms @5%, 1/4w.
		----- TERMINAL BOARDS -----
TB1	19C302086P1	Terminal board: 3-Position.
		----- MISCELLANEOUS -----
	546809P17	Contact, pin: female, brass; sim to Molex Products 1381-T.
	19B209288P2	Contact, male: 14-20 AWG; sim to Molex 02-09-2101.

★ COMPONENTS ADDED, DELETED OR CHANGED BY PRODUCTION CHANGES

★ COMPONENTS ADDED, DELETED OR CHANGED BY PRODUCTION CHANGES

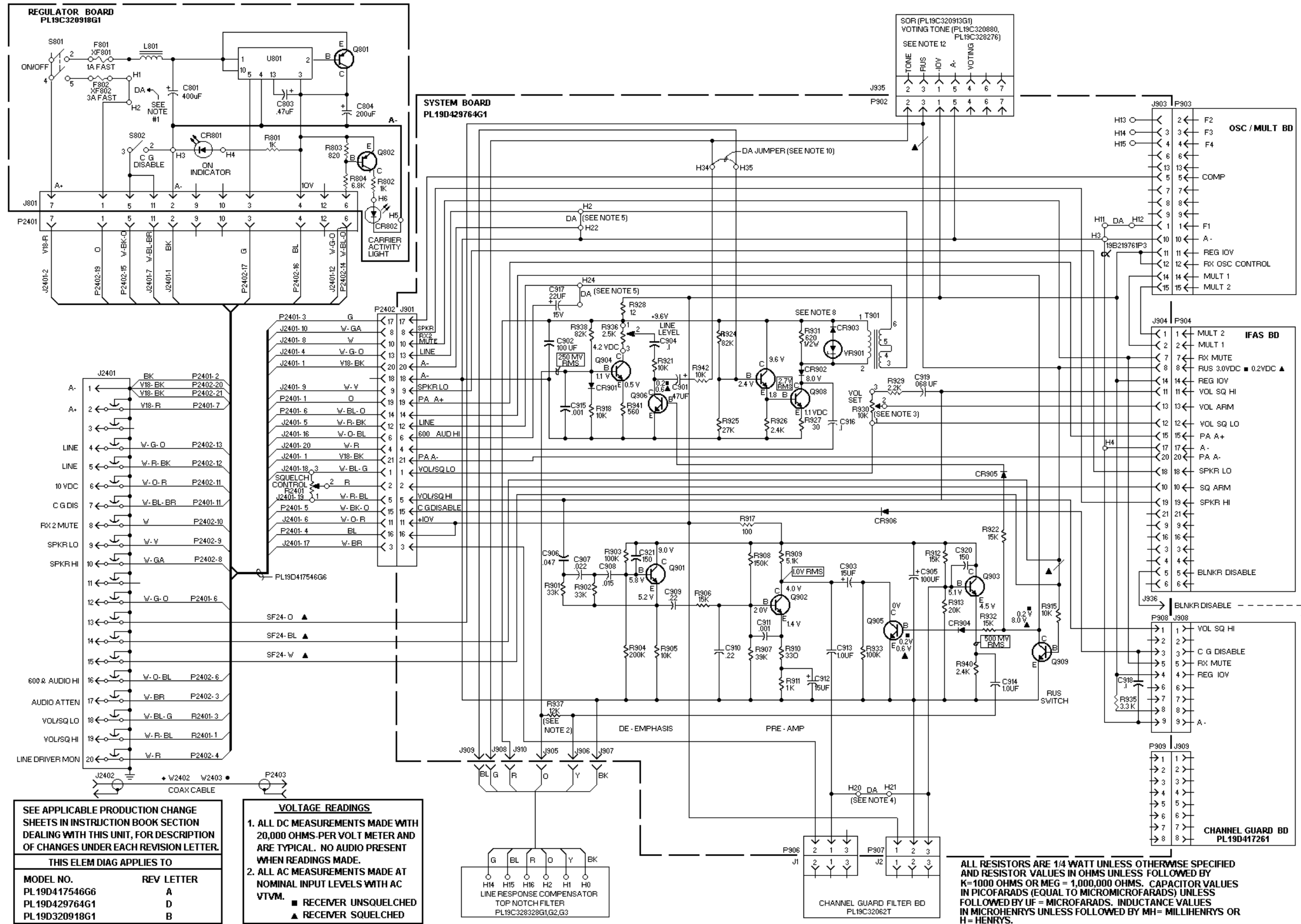

- NOTES:
- JUMPER FROM H1 TO H2 NOT PRESENT WHEN THERE IS NO LOAD, OR SPEAKER CONNECTED TO THE SPEAKER OUTPUT LEADS. (J2401-9,10).
 - WHEN TONE FILTER PL19C328328G1,3 IS PRESENT (IN TONE CONTROL SYSTEMS) R937 IS REMOVED.
 - VOL SET CONTROL R930 IS SET FOR 1 WATT AUDIO OUTPUT IN NON-LOCAL STATIONS, 5 WATTS IN LOCAL STATIONS.
 - WHEN C.G. FILTER BD 19C320627 IS NOT PRESENT, JUMPER FROM H20 TO H21 IS PRESENT.
 - WHEN AUX RECEIVER AUDIO IS RUN DOWN SEPARATE 600Ω LINE, REMOVE JUMPERS FROM H2 TO H22 AND H24 TO H25.
 - ALL WIRES N22 UNLESS OTHERWISE NOTED.
 - TERMINATE N22 WIRES TO P2401 AND P2402 WITH 19A116781P4. TERMINATE V18 WIRES TO P2401 AND P2402 WITH 19A116781P3.
 - WHEN USED WITH MASTR II STATION USING COMMON TELEPHONE LINE, R931 IS NOT PRESENT.
 - 900 MHz ONLY.
♦ LB, HB & 450 MHz.
 - WHEN LINE COMPENSATOR PL19C328328G1,G2 IS PRESENT, DA JUMPER BETWEEN H34 AND H35 IS NOT PRESENT.
 - ▲ WIRES ADDED AND RUNS CUT WHEN MODIFIED FOR PST VOTING.
 - 5.6K RESISTOR ADDED FROM J935-1 TO J935-3 WHEN MODIFIED FOR PST VOTING.

SEE APPLICABLE PRODUCTION CHANGE SHEETS IN INSTRUCTION BOOK SECTION DEALING WITH THIS UNIT, FOR DESCRIPTION OF CHANGES UNDER EACH REVISION LETTER. THIS ELEM DIAG APPLIES TO

MODEL NO.	REV LETTER
PL19D417546G6	A
PL19D429764G1	D
PL19D320918G1	B

- VOLTAGE READINGS
- ALL DC MEASUREMENTS MADE WITH 20,000 OHMS-PER VOLT METER AND ARE TYPICAL. NO AUDIO PRESENT WHEN READINGS MADE.
 - ALL AC MEASUREMENTS MADE AT NOMINAL INPUT LEVELS WITH AC VTVM.
 - RECEIVER UNSQUELCHED
 - ▲ RECEIVER SQUELCHED

ALL RESISTORS ARE 1/4 WATT UNLESS OTHERWISE SPECIFIED AND RESISTOR VALUES IN OHMS UNLESS FOLLOWED BY K=1000 OHMS OR MEG = 1,000,000 OHMS. CAPACITOR VALUES IN PICOFARADS (EQUAL TO MICROMICROFARADS) UNLESS FOLLOWED BY UF = MICROFARADS. INDUCTANCE VALUES IN MICROHENRYS UNLESS FOLLOWED BY MH= MILLIHENRYS OR H = HENRYS.

AUXILIARY RECEIVER
19D417546G7 & G8

(19E501751, Sh. 1, Rev. 9)

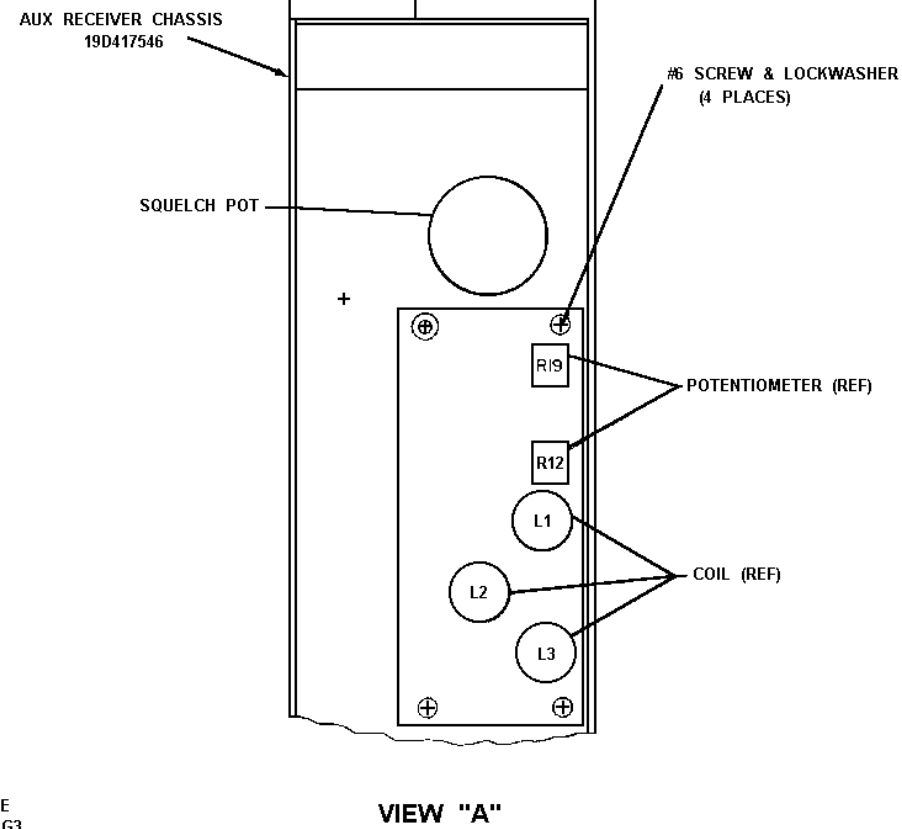
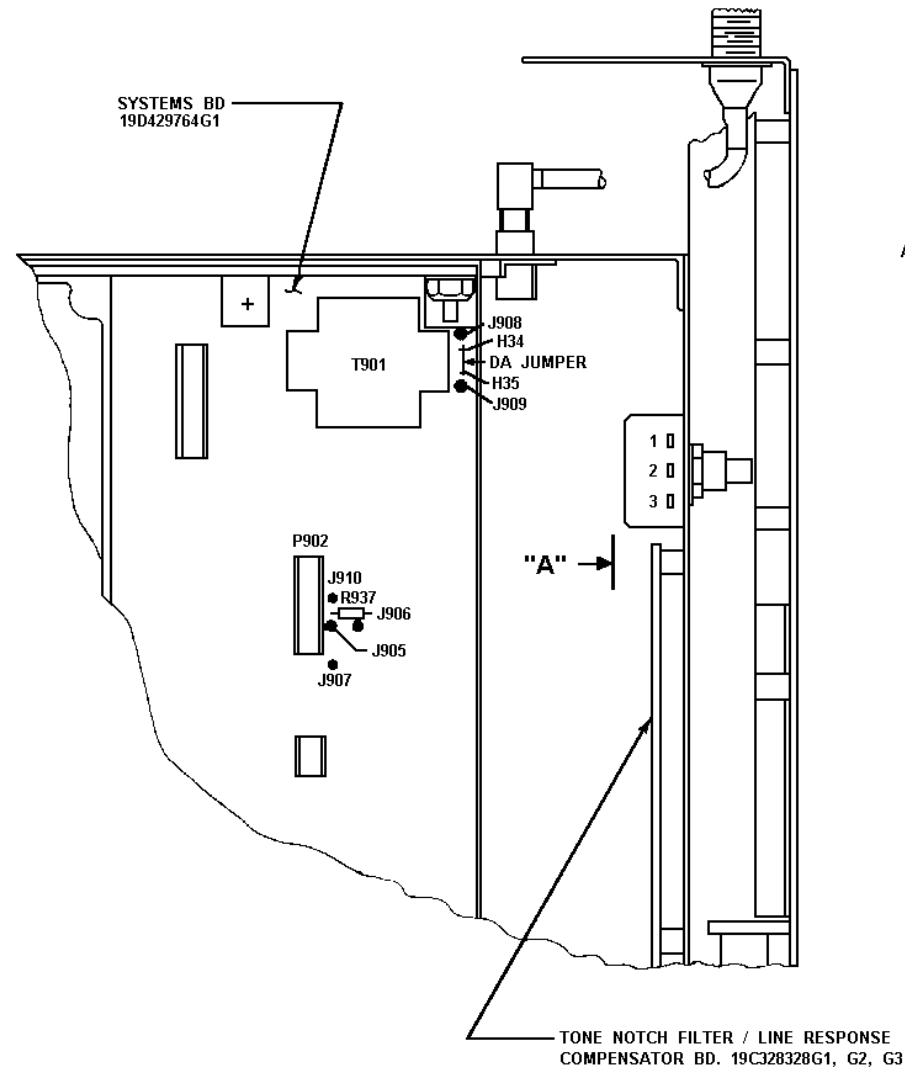

INSTRUCTIONS FOR INSTALLING THE TONE NOTCH FILTER/LINE RESPONSE COMPENSATOR BD 19C328328G1.

- 3 1. REMOVE COVER (IF PRESENT).
2. ON SYSTEM BD 19D429764G1
 - 2.1 REMOVE R937
 - 2.2 CUT OUT DA JUMPER BETWEEN H34 AND H35.
3. ASM FILTER / COMPENSATOR BD TO INSIDE OF AUX RECEIVER CHASSIS USING #6 SCREWS AND LOCKWASHERS (FURNISHED). ORIENT BD AS SHOWN IN VIEW A.
4. CONNECT GREEN WIRE FROM FILTER / COMPENSATOR BD TO J908; BLUE WIRE TO J909; RED WIRE TO J910; ORANGE WIRE TO J905; YELLOW WIRE TO J906; BLACK WIRE TO J907.
5. REPLACE COVER.

INSTRUCTIONS FOR INSTALLING LINE RESPONSE COMPENSATOR BD 19C328328G2.

- 4 1. REMOVE COVER (IF PRESENT).
2. CUT OUT DA JUMPER BETWEEN H34 AND H35 ON SYSTEM BD 19D429764G1.
3. ASM COMPENSATOR BD TO INSIDE OF AUX RECEIVER CHASSIS USING #6 SCREWS AND LOCKWASHERS (FURNISHED). ORIENT POTENTIOMETERS AS SHOWN IN VIEW A. (COILS NOT PRESENT).
4. CONNECT GREEN WIRE FROM COMPENSATOR BD TO J908; BLUE WIRE TO J909; RED WIRE TO J910; BLACK WIRE TO J907.
5. REPLACE COVER.

INSTRUCTIONS FOR INSTALLING TONE NOTCH FILTER BD 19C328328G3.

- 5 1. REMOVE COVER (IF PRESENT).
2. REMOVE R937 FROM SYSTEM BD 19D429764G1.
3. ASSEMBLE FILTER BD TO INSIDE OF AUX RECEIVER CHASSIS USING #6 SCREWS AND LOCKWASHERS (FURNISHED). ORIENT COILS AS SHOWN IN VIEW A. (POTENTIOMETERS NOT PRESENT).
4. CONNECT ORANGE WIRE FROM FILTER BD TO J905; YELLOW WIRE TO J906; BLACK WIRE TO J907.

**TONE NOTCH FILTER/LINE RESPONSE COMPENSATOR
19C328328G1-G3**

(19D417634, Sh. 3, Rev. 0)

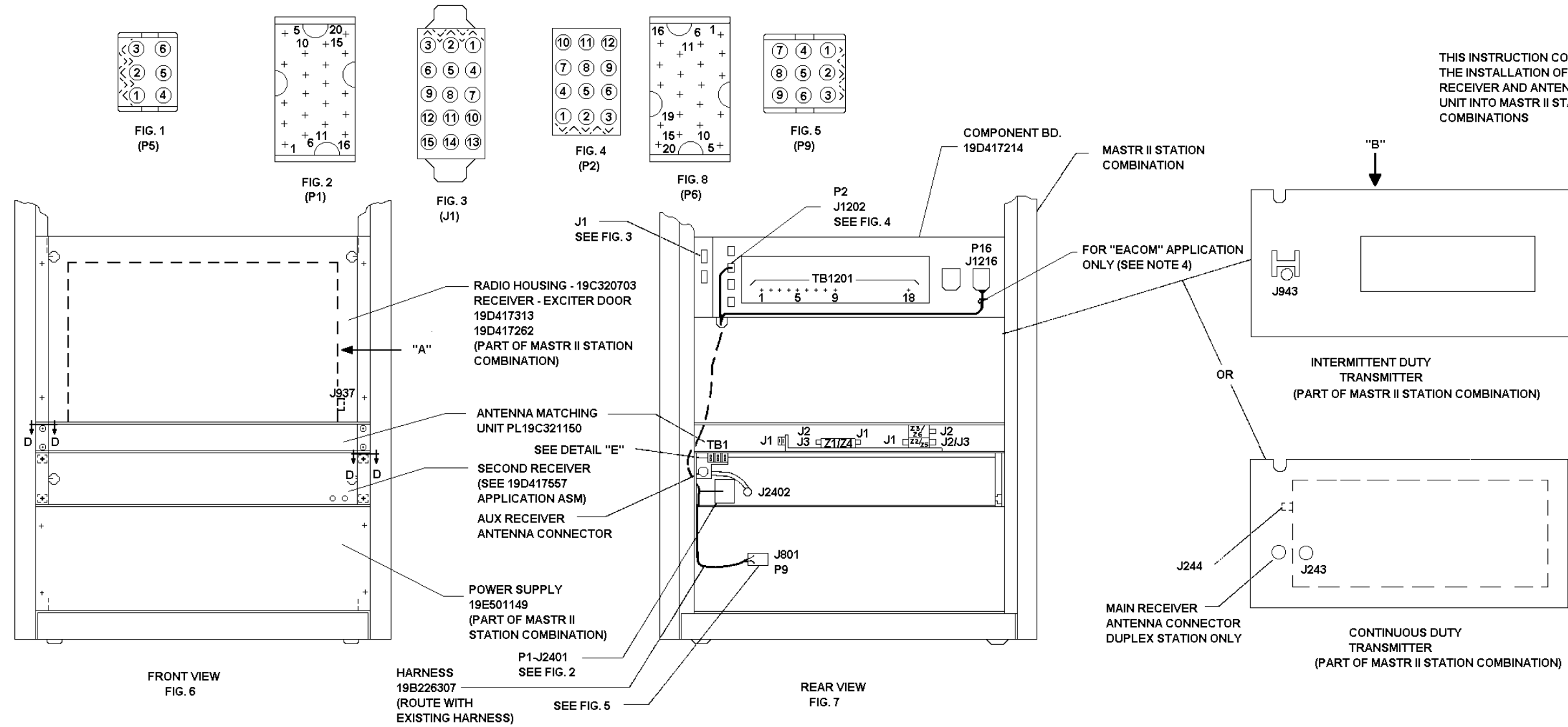

THIS INSTRUCTION COVERS THE INSTALLATION OF SECOND RECEIVER AND ANTENNA MATCHING UNIT INTO MASTR II STATION COMBINATIONS

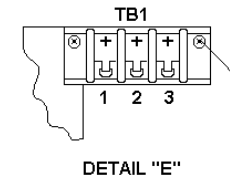
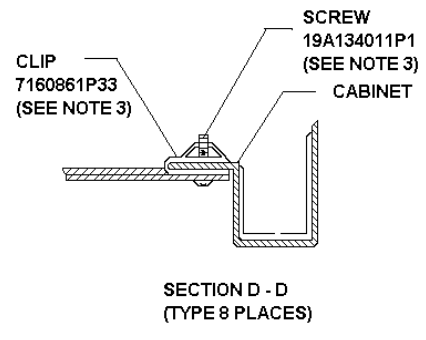
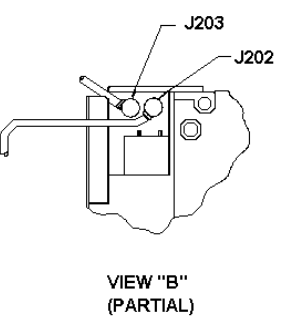
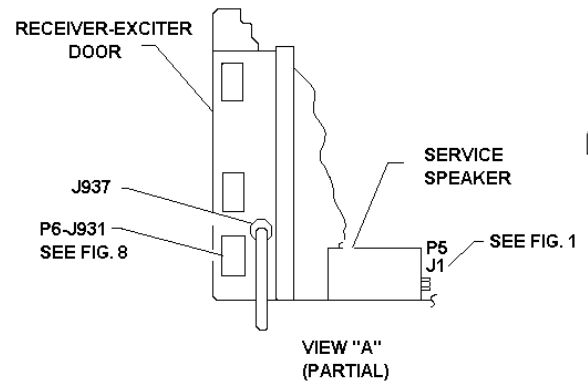

- NOTES:
- 1 - SEE COMBINATION INTERCONNECTION DIAG. 19D417611.
 - 2 -
 - 3 - PART OF HARDWARE KIT PL19A130127G2
 - 4 - SEE COMBINATION INTERCONNECTION DIAG 19D424989 FOR "EACOM" APPLICATION.
 - 5 - SEE COMBINATION INTERCONNECTION DIAG 19D429271 FOR COMBINATION WITH CHANNEL GUARD MONITOR
- 6-32 X 5/8 (2 PLACES) (SEE NOTE 3)

AUXILIARY RECEIVER & ANTENNA MATCHING UNIT

(19D417615, Sh. 1, Rev. 5)

ANTENNA CABLE CONNECTION

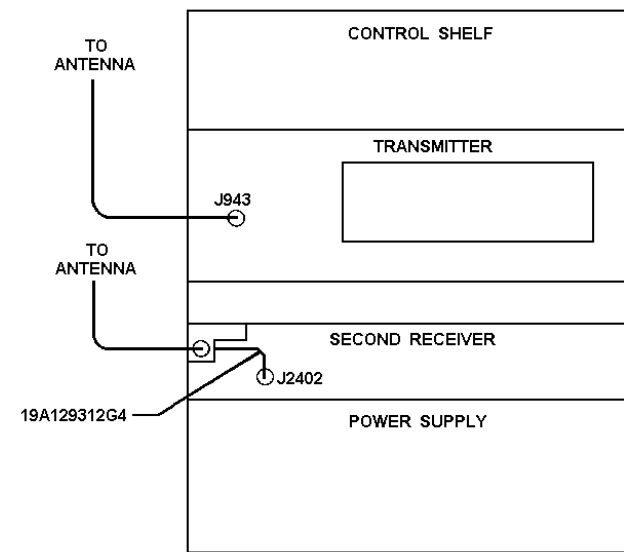

INTERMITTENT DUTY W/O AMU
 STATION COMBINATION NO.

-	I	-	-	E	-	S	-	-	-
	K			N					
	J			R					
	T			U					
				W					
				G					

 FIG. 8

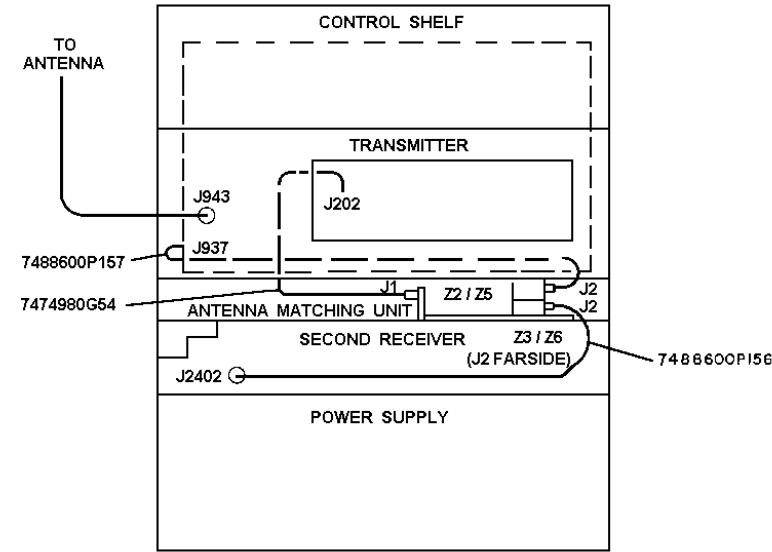

INTERMITTENT DUTY W/O AMU
 STATION COMBINATION NO.

-	I	-	-	E	-	S	-	-	-
	K			N					
	J			R					
	T			U					
				W					
				G					

 FIG. 9

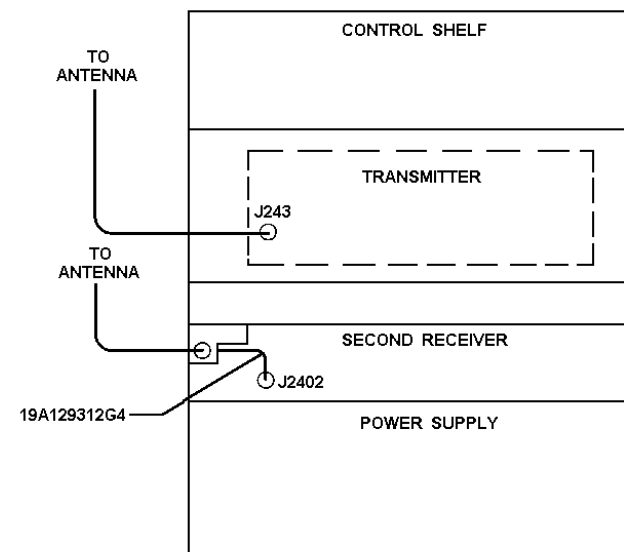

CONTINUOUS DUTY W/O AMU
 STATION COMBINATION NO.

-	C	-	-	E	-	S	-	-	-
	K			N					
	J			R					
	T			U					
				W					
				G					

 FIG. 10

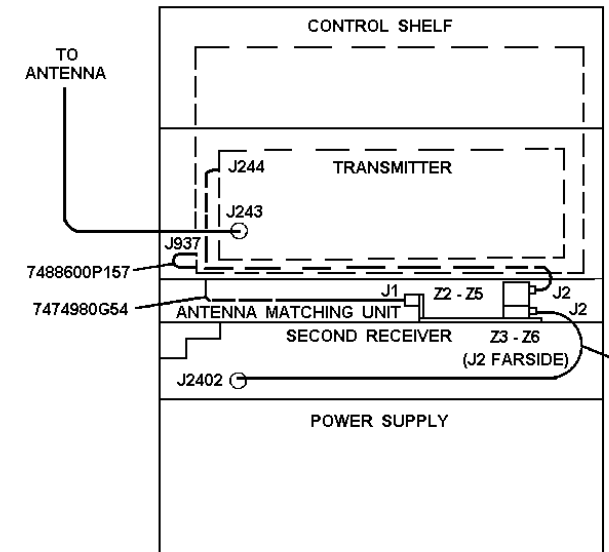

CONTINUOUS DUTY W/O AMU
 STATION COMBINATION NO.

-	C	-	-	E	-	S	-	-	-
	K			N					
	J			R					
	T			U					
				W					
				G					

 FIG. 11

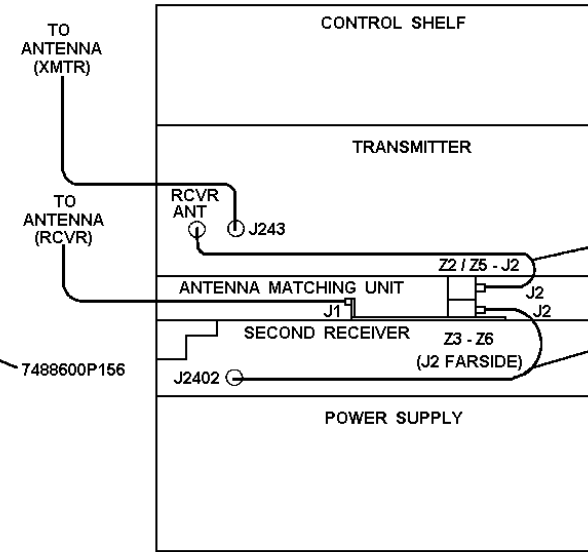

CONTINUOUS DUTY W/AMU
 (DUPLX OPERATION)
 STATION COMBINATION NO.

-	C	-	-	E	-	D	-	-	-
	K			N					
	J			R					
	T			U					
				W					
				G					

 OR

-	C	-	-	N	-	-	-	-	-
	K								
	J								
	T								

 FIG. 12

INSTRUCTIONS FOR INSTALLING:

2. AUXILIARY RECEIVER 19D417456
 1. INSTALL 4 CLIPS (7160861P33) AS SHOWN IN FIG. 6.
 2. MOUNT AUXILIARY RECEIVER IN 2 RU SPACE IMMEDIATELY ABOVE STATION POWER SUPPLY (19E9D1149) USING HARDWARE SUPPLIED (SEE FIG. 6), LEAVING A 1 RU SPACE BETWEEN AUXILIARY RECEIVER AND RADIO HOUSING (19C320703).
 3. INSTALL OVERLAY HARNESS PL19B226307 AS SHOWN IN FIG. 7. SEE INTERCONNECT DIAGRAM 19D417600 & 19D424898.
 4. REMOVE R931 FROM AUX RX SYSTEM BD 19D41749G1. (SEE FIG. 13).

THIS INSTRUCTION COVERS THE INSTALLATION OF SECOND RECEIVER AND ANTENNA MATCHING UNIT INTO MASTR II STATION COMBINATIONS.

1. ANTENNA MATCHING UNIT PL19C321150
 1. MOUNT ANTENNA MATCHING UNIT IMMEDIATELY BELOW RADIO HOUSING (19C320703), LEAVING 2 RU SPACE BETWEEN ANTENNA MATCHING UNIT AND STATION POWER SUPPLY (19E9D1149) FOR AUXILIARY RECEIVER. IF NOT PRESENT. (SEE FIG. 6 & FIG. 7).
 2. MOUNT AUXILIARY RECEIVER IN 2 RU SPACE BETWEEN ANTENNA MATCHING UNIT AND STATION POWER SUPPLY. IF NOT ALREADY PRESENT. (SEE INSTRUCTION FOR MOUNTING AUXILIARY RECEIVER).
 3. CONNECT RF CABLES AS SHOWN IN FIG. 9 OR FIG. 11 OR FIG. 12 OR FIG. 14.
 4. PKG ANY EXTRA CABLES & SHIP W/STATION.
 5. IN FIG. 14 DISCONNECT W1 FROM Z1/Z4 -J1 AND TAPE TO ANTENNA MATCHING UNIT J1 FOR MECHANICAL SUPPORT.

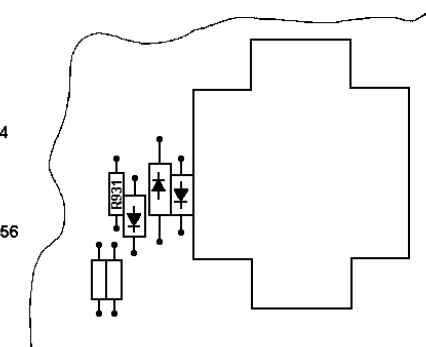
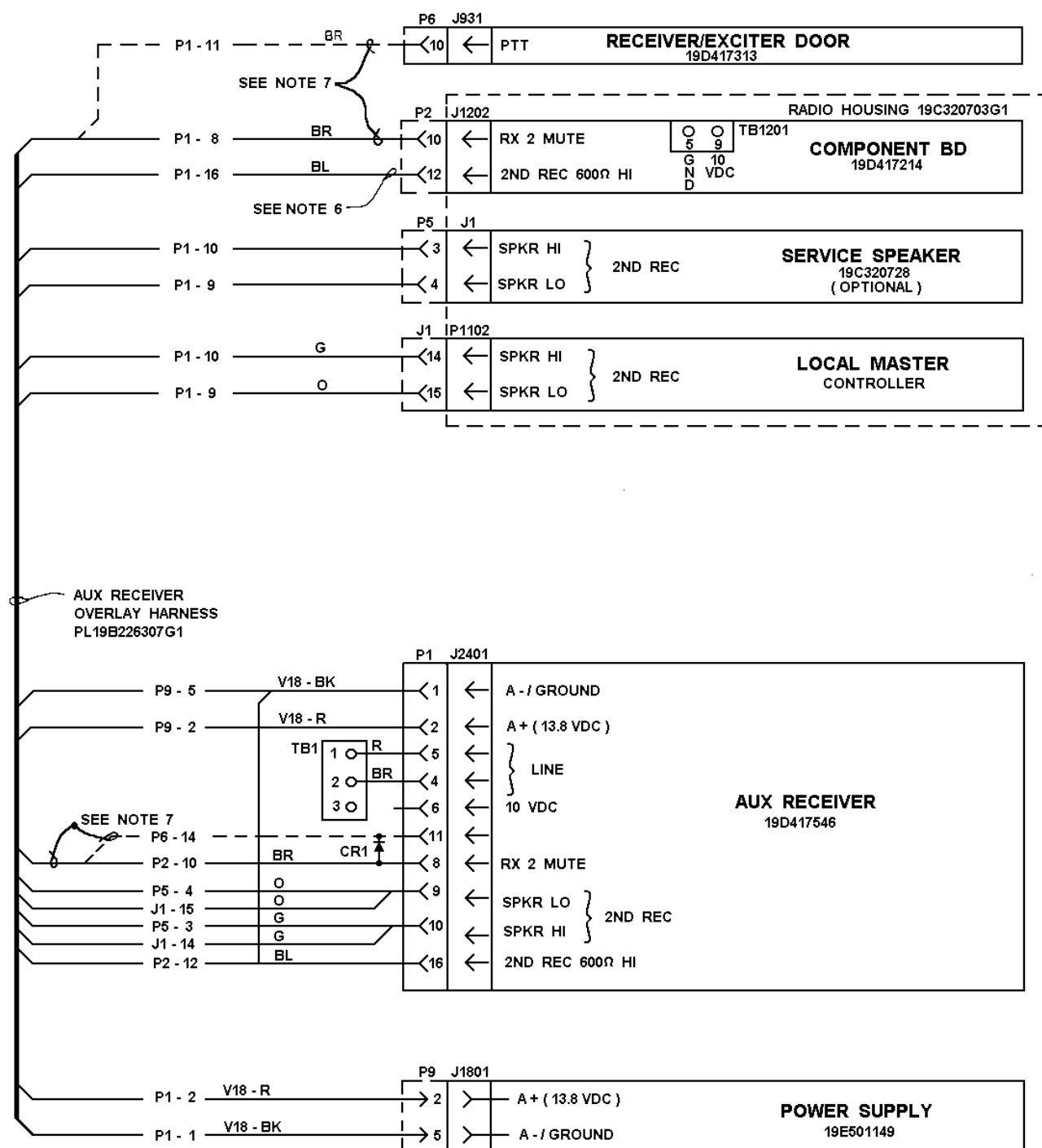

FIG. 13

AUXILIARY RECEIVER & ANTENNA MATCHING UNIT

(19D417615, Sh. 2, Rev. 8)



- NOTES: (FOR PL19B226307 WIRING HARNESS)
- ALL WIRE TO BE SF-22 UNLESS OTHERWISE NOTED.
 - WIRES TO P2, J1 & P5 TO BE TERMINATED WITH C5496809P17.
 - WIRES TO P9 TO BE TERMINATED WITH 19B209288P2.
 - CONNECTORS P2, P5, P6, P9 & J1 ARE PART OF 19C320811 HARNESS.
 - CONNECTIONS TO P1 & TB1 TO BE SOLDERED.
 - ON ALL STATIONS WITH LOCAL CONTROL, (COMBINATION NO. V-E-J-K), TAPE BACK OR SLEEVE BLUE WIRE.
 - INCORPORATED ONLY IN LOCAL CONTROL INTERMITTENT DUTY STATIONS (COMBINATION NO. -1-E-).
 - ROUTE THE BR WIRE TO THE RECEIVER/EXCITER DOOR. CONNECT AND SOLDER TO P1-14.
 - ON THE AUX RX, REMOVE THE BR WIRE FROM P1-8 AND CONNECT TO P1-11.
 - ON THE AUX RX, ADD DIODE CR1 (FROM HDW KIT 19A130127G2) WITH ANODE CONNECTED TO P1-8 AND CATHODE CONNECTED TO P1-11. SOLDER BOTH CONNECTIONS.

**AUXILIARY RECEIVER OVERLAY HARNESS
19B226307G1**

(19D417611, Sh. 1, Rev. 12)

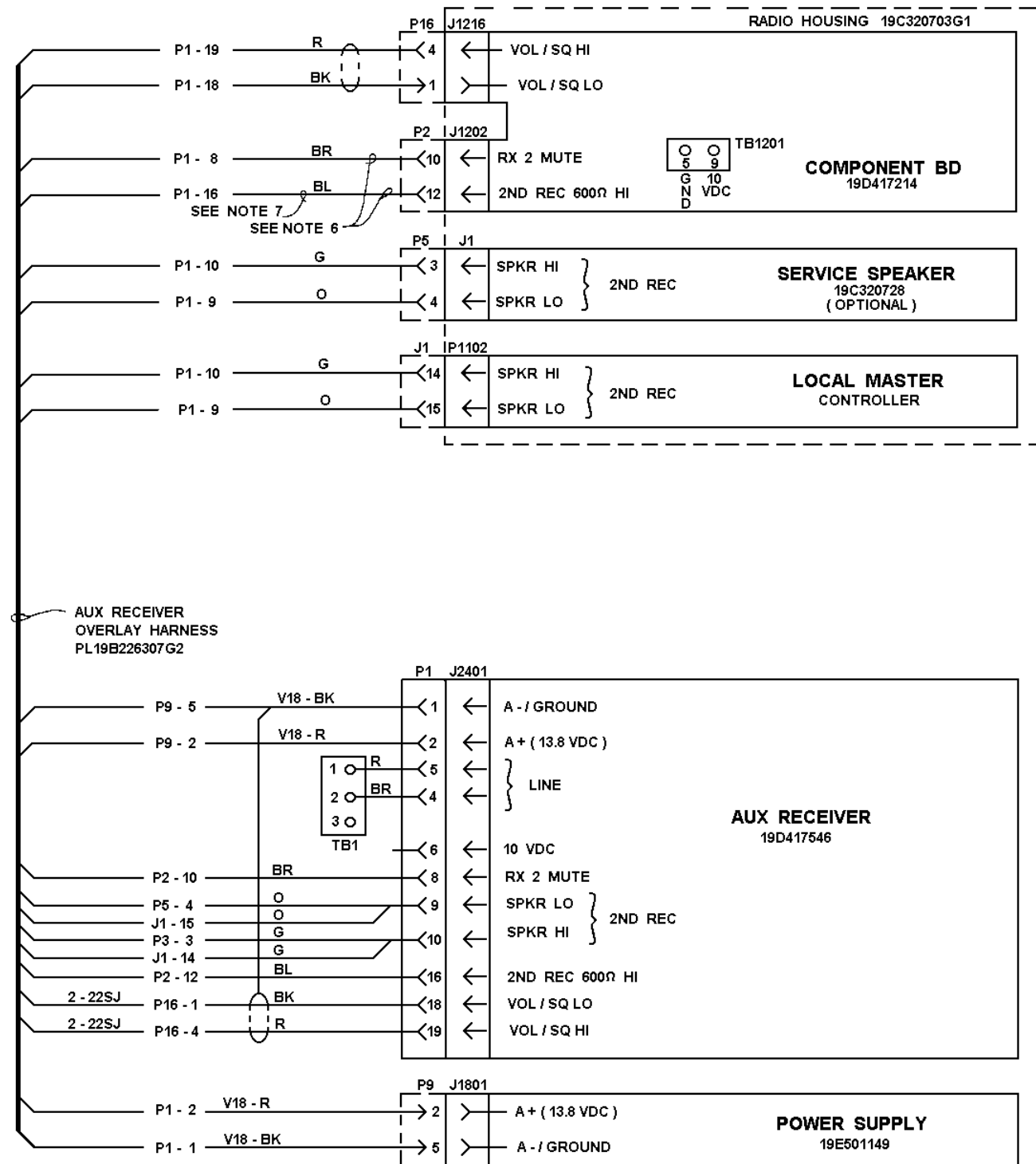

- NOTES: (FOR PL19B226307 WIRING HARNESS)
1. ALL WIRW TO BE SF22 UNLESS OTHERWISE NOTED.
 2. WIRES TO P2, P5, P16-4 & J1 TO BE TERMINATED WITH 19B209288P29.
 3. TERMINATE WIRE AT P16-1 WITH 19B209288P30.
 4. WIRES TO P9 TO BE TERMINATES WITH 19209288P2
 5. CONNECTORS P2, P5, P9 & J1, ARE PART OF 19C320811 HARNESS.
 6. CONNECTIONS TO P1 & TB1 TO BE SOLDERED.
 7. IF P2 IS NOT PRESENT, TAPE OR SLEEVE BR & BL WIRES.
 8. IN LOCAL/REMOTE STATIONS TAPE BLACK OR SLEEVE BLUE WIRE.

**AUXILIARY RECEIVER OVERLAY HARNESS (EACOM)
19B226307G2**

(19D424989, Rev. 3)

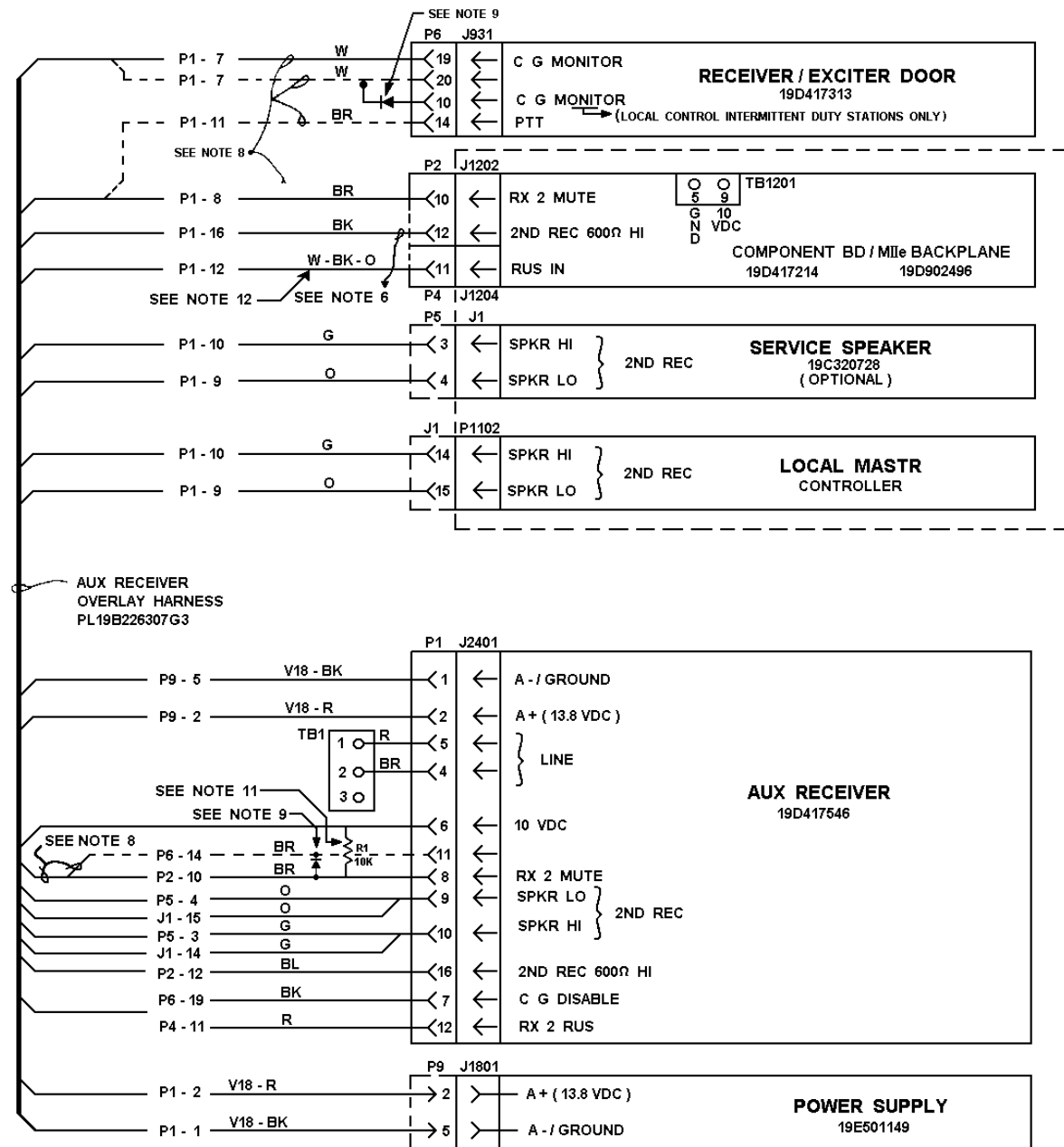

OPTION 9541

THESE INSTRUCTIONS COVER THE MODIFICATION OF THE 19D417213 SYSTEM BD FOR USE IN THE FOLLOWING SYSTEMS:

- 4 FREQ TX WITH 4 SEPARATE RECEIVERS W/CHANNEL GD.
- 4 FREQ TONE REMOTE W/CHANNEL GD.
- 4 FREQ REMOTE/REPEAT W/CHANNEL GD.
- AUX RCVR W/CHANNEL GD.

INSTRUCTIONS:

- REMOVE DA JUMPER BETWEEN H68 & H69.
- INSTALL 19A11520P1 DIODE (SUPPLIED IN KIT PL19A137396) BETWEEN H68 & H69 OBSERVING POLARITY SHOWN.
- SOLDER ALL ELECTRICAL CONNECTIONS.

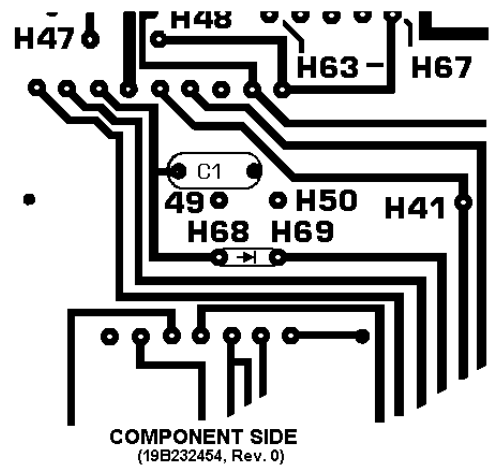

- NOTES: (FOR PL19B226307 WIRING HARNESS)
- ALL WIRE TO BE SF-22 UNLESS OTHERWISE NOTED.
 - WIRES TO P2, P4, J1 & P5 TO BE TERMINATED WITH C5496809P17.
 - WIRES TO P9 TO BE TERMINATED WITH 19B209288P2.
 - CONNECTORS P2, P4, P5, P6, P9, & J1 ARE PART OF 19C320811 HARNESS.
 - CONNECTIONS TO P1, P6 & TB1 TO BE SOLDERED.
 - ON ALL STATIONS WITH LOCAL CONTROL, (COMBINATION NO. V-E-J-K), TAPE BACK OR SLEEVE BLUE WIRE.
 - STRIP & TIN W WIRE TO P6 .31 ± .06 & LET HANG. CONNECTION IS MADE AT INSTALLATION.
 - DASHED LINES SHOW HARNESS AS MODIFIED FOR USE IN LOCAL CONTROL INTERMITTENT DUTY STATIONS.
 - DIODE SUPPLIED AS MODIFACATION KIT PL19A137396G1. INSTALLED ONLY WHEN HARNESS IS MODIFIED PER NOTE
 - INCORPORATE ONLY IN LOCAL CONTROL INTERMITTENT DUTY STATIONS (COMBINATION NO. -1-E ---).
 - ROUTE THE BR WIRE TO THE RECEIVER/EXCITER DOOR. CONNECT AND SOLDER TO P6-14.
 - ON AUX RX REMOVE THE BR WIRE FROM P1-8 AND CONNECT TO P1-11.
 - ON THE AUX-RX ADD DIODE CR1 (FROM HDW KIT 19A130127G2) WITH ANODE CONNECTED TO P1-8 AND CATHODE CONNECTED TO P1-11. SOLDER BOTH CONNECTIONS.
 - REMOVE R1 FOR APPLICATIONS OTHER THAN
 - CUT AND TIE BACK FOR APPLICATIONS OTHER THAN MASTR IIe.
 - CUT JUMPER BETWEEN P27-14 & 15 ON STATION HARNESS 19C320811G16 FOR MASTR IIe APPLICATIONS.

THIS ELEM. DIAGRAM APPLIES TO

MODEL NO.	REV. LETTER
PL19B226307G3	A

(19D429271, Rev. 3)

AUXILIARY RECEIVER OVERLAY HARNESS WITH CHANNEL GUARD MONITOR