

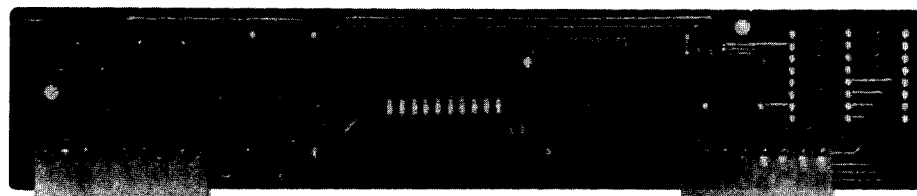

GE Mobile Communications



MASTR[®] II
PROGRAMMABLE CHANNEL GUARD
19D432500G1-3

TABLE OF CONTENTS

SPECIFICATIONS	ii
DESCRIPTION	1
OPERATION	1
CIRCUIT ANALYSIS	1
Encode Mode	1
Decode Mode	2
MAINTENANCE	2
INSTALLATION	2
TROUBLESHOOTING PROCEDURE	3
OUTLINE DIAGRAMS	
Channel Guard	4
Extender Board	4
SCHEMATIC DIAGRAM	5 & 6
PARTS LIST AND PRODUCTION CHANGES	5 & 6
MODIFICATIONS IN VOICE GUARD E/D APPLICATIONS	7
PROGRAMMING INSTRUCTIONS	8
CHANNEL GUARD STRAPPING	8

SPECIFICATIONS*

Input Voltage	10 Volts DC
Current Drain	50 Milliampères Maximum
Frequency Range	67-210.7 Hz
Maximum Frequency	±0.2%
Encode Output Level	
67 Hz	0.8 Volts RMS Minimum
156 Hz	0.4 Volts RMS Minimum
210 Hz	0.2 Volts RMS Minimum
Encode Tone Distortion	1.5% Maximum
Programming Increments	0.25 Hz
Decode Input Level	45 Millivolts RMS Minimum
Decode Response Time	250 Milliseconds Maximum @ 100 Hz
PTT Delay	160 Milliseconds
STE Phase Shift	135°
Temperature Range	-30°C (-22°F) to +60°C (140°F)

* These specifications are intended primarily for the use of the serviceman. Refer to the appropriate Specification Sheet for the complete specifications.

WARNING

Although the highest DC voltage in the unit is supplied by the vehicle battery, high current may be drawn under short circuit conditions. These currents can possibly heat metal objects such as tools, rings, watchbands, etc. enough to cause burns. Be careful when working near energized circuits.

Copyright © 1981, General Electric Company



GE Mobile Communications

General Electric Company
Lynchburg, Virginia 24502

DESCRIPTION

General Electric Channel Guard Modules 19D432500 are field programmable, synthesized single tone Channel Guard encoder/decoders for use with MASTR® II mobile radios.

The encode function provides continuous tone-coded modulation for the transmitter. The decode function is used with the receiver to eliminate all calls that are not tone coded with the proper Channel Guard (CG) frequency.

Three different Channel Guard boards are available:

- 19D432500G1 - single tone encode/decode
- 19D432500G2 - single tone encode only
- 19D432500G3 - single tone decode only

OPERATION

In mobile Channel Guard applications, a microphone hookswitch is supplied with the radio. The CG hookswitch is equipped with a CG disable switch.

Placing the disable hookswitch in the "up" position (towards the small speaker symbol) disables the receive Channel Guard. With the switch in the "down" position, the receive Channel Guard is disabled when the microphone is removed from the hookswitch.

In station applications, a desk microphone is available for use with Channel Guard. Pressing the MONITOR bar on the base of the desk microphone disables the CG decode function. This permits the channel to be monitored before sending a message.

CIRCUIT ANALYSIS

Channel Guard is a continuous-tone controlled squelch system that provides communications control in accordance with EIA standard RS-220-A. The basic Channel Guard system utilizes standard tone frequencies from 67 to 210.7 Hz with both the encoder and decoder operating on the same frequency. The standard Channel Guard tone frequencies are shown in the following chart.

STANDARD TONE FREQUENCIES				
67.0	88.5	107.2	131.8	167.9
71.9	91.5	110.9	136.5	173.8
74.4	94.8	114.8	141.3	179.9
77.0	97.4	118.8	146.2	186.2
79.7	100.0	123.0	151.4	192.8
82.5	103.5	127.3	156.7	203.5
85.4			162.2	210.7

The Channel Guard circuitry consists of frequency synthesizer U1001, encoder/decoder U1002/U1003, tone programming switch S1001 and associated discrete circuitry.

Frequency synthesizer U1001 includes the synthesizer IC and a 32,768 Hz reference crystal that provides the clock inputs for the encoder/decoder module. The clock inputs are required to produce the tone frequency and the digitally generated time delays for the DELAYED PTT and squelch tail elimination (STE) circuits.

Tone frequency programming is accomplished by setting the 10 station switch (S1001) for the proper binary input to the synthesizer. The switch can be set to produce any CG tone from 67 Hz to 210.7 Hz in 0.25 Hz increments. Complete instructions for setting the switch are contained in the Programming Instructions (see Table of Contents).

Encode/decode hybrid U1002 contains the encoder and decoder, a voice reject filter, STE circuit and the interface circuitry. The interface circuitry provides increased output drive for RX MUTE, DELAYED PTT (Push-To-Talk) and other functions. Encode hybrid U1003 has the decoder removed for encode only operation.

ENCODE MODE

Depressing the PTT switch applies a low (A-) to PTT lead J908-6. This causes the DELAYED PTT lead (J908-8) to go low, keying the transmitter. The encoder then generates the CG tone which is applied to a low pass filter to remove any tone or clock harmonics. The filter output is then coupled through J908-7 to the transmitter.

NOTE

When jumper W1003 is connected, the tone output has a 6 dB/octave de-emphasis required for phase modulation transmitters. Jumper W1003 is removed for direct FM transmitters.

When the PTT button on the microphone is released (transmitter unkeyed), the DELAYED PTT circuit in U1002/U1003 keeps the transmitter keyed for an additional 160 milliseconds. During the 160 milliseconds delay time, the encoder shifts the phase of the CG tone output 135°. This combination of 160 milliseconds delay and the 135° phase shift causes the CG decoder in other receivers to squelch the audio before the loss of RF signal, eliminating the receiver noise burst (squelch tail elimination).

The encoder circuit can be disabled to allow the serviceman to make transmitter distortion and modulation checks. To disable the encoder, apply a ground to J908-2.

DECODE MODE

In the receive mode, receiver audio from VOLUME/SQUELCH HI lead J908-1 is applied to a voltage divider (R1002 and R1003) and then to a voice reject filter in the decode circuit. The filter removes any voice information to prevent voice blocking of clipping.

The digital decoder compares the frequency of the incoming tone to a reference clock input produced by the synthesizer. If the correct tone is detected, the decoder circuit causes the REC MUTE lead at J908-5 to go high, un-squelching the receiver. The REC MUTE lead is normally held in a low voltage condition until a correct CG tone is detected.

After the CG tone is decoded, the decoder then waits for a phase shift in the tone to occur. When the phase shift occurs, the STE delay circuit in the decoder pulls the REC MUTE lead to a low voltage state. This squelches the receiver for 200 milliseconds and keeps the receiver squelched until the RF carrier applied to the receiver is removed.

The decode circuit can be disabled by grounding J908-3.

MAINTENANCE

Troubleshooting the Channel Guard assembly is facilitated when using the Channel Guard extender board (19C320966G1). The extender board contains three slide switches which disable the decode and encode circuitry, and also bridges the PTT input to the delayed PTT output when the CG board is removed. In addition, "test points" are provided for all pins on J908.

PTT Bridge - Allows the transmitter to be keyed when the Channel Guard board is removed. Note: If transmitter is keyed with Channel Guard installed and PTT bridge closed the Channel Guard PTT delay will lock up until PTT bridge is opened.

Encode Disable - Applies A- to pin 2 of J908 and Pin 11 of the Encode IC to prevent transmitting the Channel Guard Tone.

Rx CG Disable - Applies A- to J908-3 and pin 2 of the Decode IC to disable the decoder. Under this condition the receiver is not muted.

A troubleshooting chart provides a method of checking the Channel Guard functions.

INSTALLATION

IN MOBILE RADIOS

To install Channel Guard in radios not previously equipped with this feature, proceed as follows:

1. Gain access to System Board and clip out the DA jumper wire between H71 and H72 on the System Board (Refer to the MASTR II Maintenance Manual for the Front Panel and System Board).
2. Plug the Channel Guard unit into J908 and J909 on the System Board.
3. Install the hookswitch to the control unit as directed in the Control Unit Maintenance Manual.
4. Adjust transmitter deviation in accordance with the Alignment Procedures in the Transmitter Maintenance Manual. No other adjustments are required.

IN STATIONS

Refer to the Station Combination Maintenance Manual for installation instructions.

CHANNEL GUARD STRAPPING

When an "open" channel is required on a multi-frequency radio, the encode/decode function on the Channel Guard board must be disabled for each "open" channel. This modification may be incorporated into any of the Channel Guard boards.

Refer to the Schematic Diagram and Strapping Diagram for strapping instructions.

REPEATER APPLICATION

The following modification must be made on the Programmable Decode only Channel Guard Board 19D432500G3 when used in a repeater application.

Cut the PWB pattern on solder side that connects to U1002-8.

REMOVING INTEGRATED CIRCUITS

Removing IC's (and all other soldered-in components) can be easily accomplished by using a de-soldering tool such as a SOLDA•PULLT® or equivalent. To remove an IC, heat each lead separately on the solder side and remove the old solder with the de-soldering tool.

An alternate method is to use a special soldering tip that heats all of the pins simultaneously.

TROUBLESHOOTING PROCEDURE

Before starting the TROUBLESHOOTING PROCEDURE, check to see that +10 volts and ground are connected to the Channel Guard board.

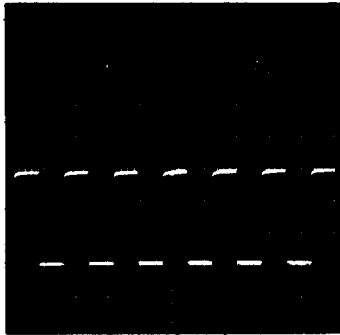
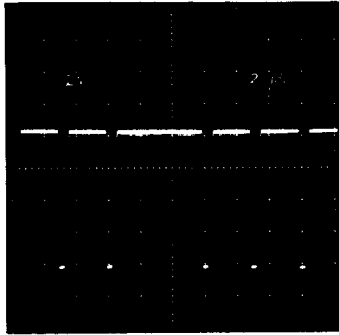
SYMPTOM	PROCEDURE
No Encode Tone	Check the PTT lead for a "low" (0.7 volt or less). Next, check the TX CG DSBL lead for 1.5 to 5 volts. If a "low" is not present on the PTT lead check the microphone and hook-switch circuits. If a "high" is present on the TX CG DISABLE lead, check the DELAY CLOCK output at U1001-9 for 64 Hz and the TONE CLOCK output at U1001-8 for 256 times the Channel Guard (CG) frequency. EXAMPLE: If the CG frequency is 100 Hz, the TONE CLOCK output should be 25,600 Hz (see waveforms below).
Encode Disable (Tone present when CG disabled)	If either clock output is not present, replace U1001. If both clock outputs are correct, check U1001-5 for a tone output. If no tone is present, replace U1002/U1003. Key the microphone and check for a tone output at J908-7. If no tone output, make the checks listed for "No Encode Tone". If tone is present, ground the TX CG DSBL lead (J908-3). Tone should not be present at CG HI lead. If tone is present, replace U1002/U1003.
No Decode (Receiver won't unscquelch)	With the correct CG tone applied and the CG DSBL lead high (or open), the REC MUTE lead should be "high". If not, check the clock outputs at U1003-8 (256 x CG Freq.) and U1003-9 (64 Hz). If clock outputs are incorrect, perform the steps called for in "Wrong Encode or Decode Tone".
Decode Disable (Receiver won't unscquelch with disabled)	With the correct CG tone applied to VOL/SQ HI, the REC MUTE lead should go "high". Next, ground the CG DSBL input J908-3 and check to see that the RX MUTE lead goes "high" (approx. CG 10 volts). If the REC MUTE lead does not go "high", replace U1001.
Wrong Encode or Decode Tone	Check to determine that S1001 is programmed for the correct CG frequency (refer to the FREQUENCY PROGRAMMING INSTRUCTIONS listed in the Table of Contents). If S1001 is set correctly, check the tone programming pins at U1001-2 thru -7 and -10 thru -13. NOTE: Logic "1" is approx. supply voltage and logic "0" is approx. A-. If logic readings correspond to S1001 settings, replace U1002/U1003. If readings do not correspond to S1001 settings, replace S1001.
Scquelch Tail Present (no STE)	When the PTT lead is "low", P1005-8 should be "low". When the PTT lead goes "high" (PTT released), the PTT DELAYED lead should remain "low" for an additional 160 milliseconds. If not, replace U1002/U1003.
 <p data-bbox="524 1896 690 1923">64 Hz Clock</p>	 <p data-bbox="984 1896 1409 1923">256 X CG Tone (Tone - 100 Hz)</p>

CHANNEL GUARD

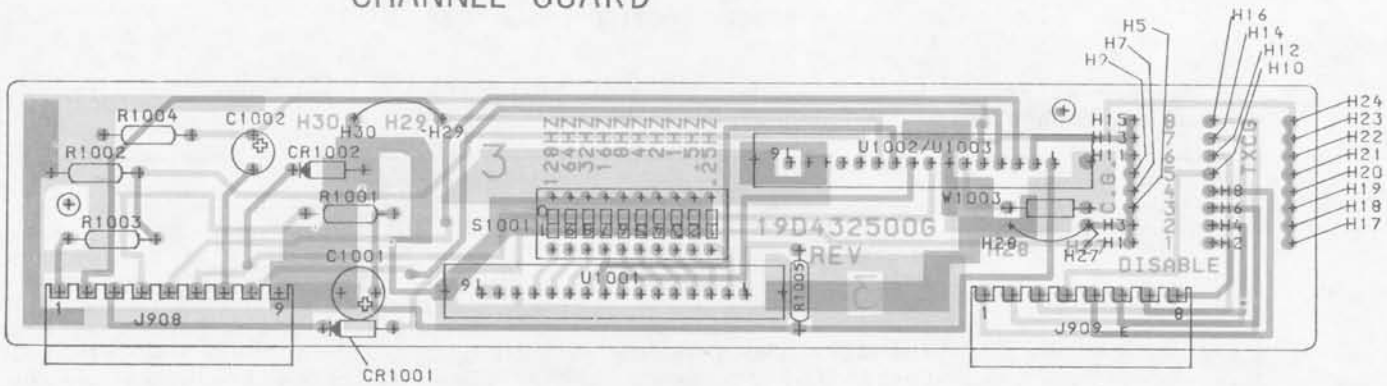

(19D432506, Rev. 2)
 (19A143571, Sh. 1, Rev. 3)
 (19A143571, Sh. 2, Rev. 3)

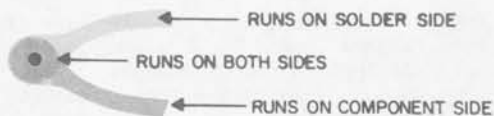

CHANNEL GUARD EXTENDER BOARD

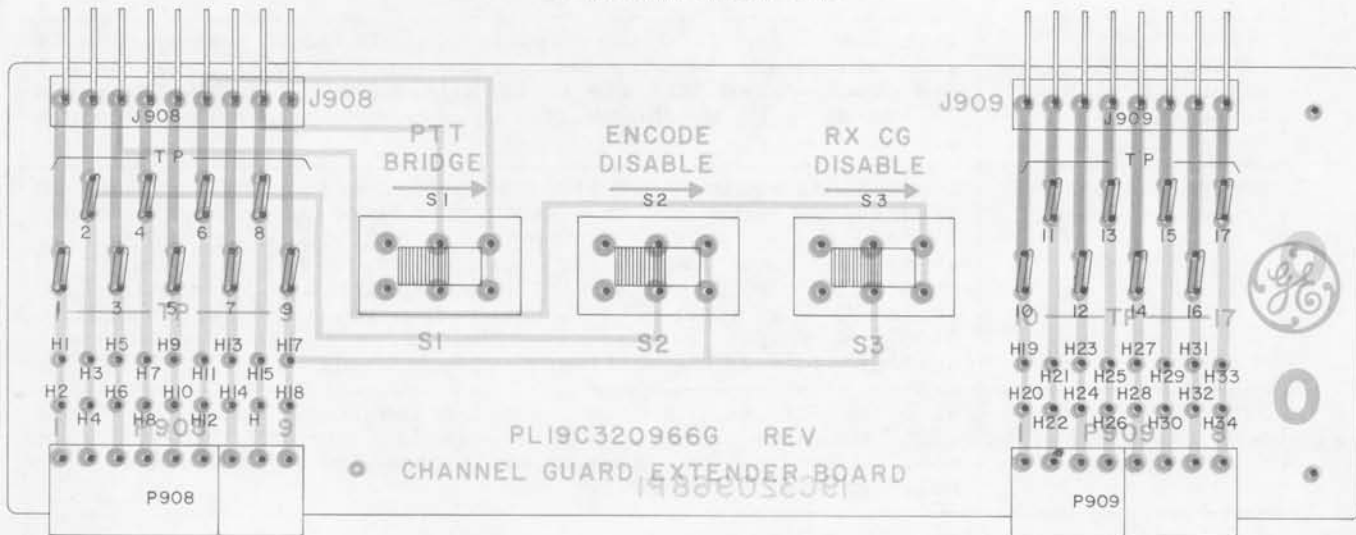

(19C321121, Rev. 0)
 (19C320968, Sh. 2, Rev. 0)
 (19C320968, Sh. 3, Rev. 0)

OUTLINE DIAGRAMS

CHANNEL GUARD AND
 CHANNEL GUARD EXTENDER BOARD

PARTS LIST

CHANNEL GUARD ENCODER/DECODER
 19D432500G1 ENCODE/DECODE - REV D
 19D432500G2 ENCODE ONLY - REV C
 19D432500G3 DECODE ONLY - REV C
 ISSUE 5

LBI31056

SYMBOL	GE PART NO.	DESCRIPTION
----- CAPACITORS -----		
C1001	19A701534P8	Tantalum: 22 uF ±20%, 16 VDCW.
C1002	19A701534P6	Tantalum: 4.7 uF ±20%, 35 VDCW.
----- DIODES AND RECTIFIERS -----		
CR1001 and CR1002	19A700028P1	Silicon, fast recovery: fwd current 75 mA, 75 PIV; sim to Type 1N4148.
----- JACKS AND RECEPTACLES -----		
J908	19A116659P76	Connector, printed wiring: 9 contacts rated at 5 amps; sim to Molex 09-52-3091.
J909	19A116659P77	Connector, printed wiring: 8 contacts rated at 5 amps; sim to Molex 09-52-3081.
----- RESISTORS -----		
R1001	H212CRP010C	Deposited carbon: 10 ohms ±5%, 1/4 w.
R1002	H212CRP322C	Deposited carbon: 22K ohms ±5%, 1/4 w.
R1003	H212CRP333C	Deposited carbon: 33K ohms ±5%, 1/4 w.
R1004	H212CRP239C	Deposited carbon: 3.9K ohms ±5%, 1/4 w.
R1005	H212CRP122C	Deposited carbon: 220 ohms ±5%, 1/4 w.
----- SWITCHES -----		
S1001	19B800010P1	Push: 10 station, contacts rated 25 mA at 24 VDC; sim to CTS 206-10.
----- INTEGRATED CIRCUITS -----		
U1001	19D900260G1	Frequency Synthesizer.
U1002	19D900496G1	Channel Guard, Encode/Decode Hybrid.
U1003	19D900496G2	Channel Guard, Encode Hybrid.
----- CABLES -----		
W1003	19A700184P1	Jumper.

*COMPONENTS ADDED, DELETED OR CHANGED BY PRODUCTION CHANGES

PRODUCTION CHANGES

Changes in the equipment to improve performance or to simplify circuits are identified by a "Revision Letter," which is stamped after the model number of the unit. The revision stamped on the unit includes all previous revisions. Refer to the Parts List for descriptions of parts affected by these revisions.

REV. A - Channel Guard Board 19D432500G1-G3
 Incorporated in original shipment

REV. B - Channel Guard Board 19D432500G1-G2
 To provide similar tone output levels for single tone and multitone synthesized channel guard units. Changed R1004 to 3.9K ohms. Old part number for R1004 was:
 19A700019P45- Deposited carbon 4.7K ohms ±5% 1/4W.

REV. C - Channel Guard Board 19D432500G1
 REV. B - Channel Guard Board 19D432500G3
 To improve channel guard decode sensitivity. Changed R1002 from 12 K ohms to 22K ohms and R1003 from 47K ohms to 33K ohms. Old part number was:
 R1002- 19A700019P50-Deposited carbon; 12K ohms ±5%, 1/4W.
 R1003- 19A700019P57-Deposited carbon; 47K ohms ±5%, 1/4W.

REV. D - Programmable Channel Guard Board 19D432500G1
 REV. C - Programmable Channel Guard Board 19D432500G2.3
 To improve performance of synthesizer hybrid at high temperatures. Added R1005.

OPENING A SWITCH STATION, ADDS THE FREQUENCY ASSOCIATED WITH IT, TO THE CG FREQUENCY TO BE ENCODED OR DECODED.

NOTES:

- 1 NOT USED IN GROUP 2.
- 2 TO CONVERT GROUP 1 TO GROUP 3 CONNECT H29 TO H30, USING DA WIRE.
- 3 TO CONVERT GROUP 1 TO GROUP 2 CONNECT H27 TO H28, USING DA WIRE.
- 4 NOT USED IN GROUP 3
- 5 USED IN GROUP 2 ONLY
- 6 FOR 6dB/OCT DE-EMPHASIS INSTALL W1003.
- 7 USED IN GROUP 3 ONLY.
- 8 THIS PATTERN CUT IN GRP 3 FOR REPEATER OPERATION

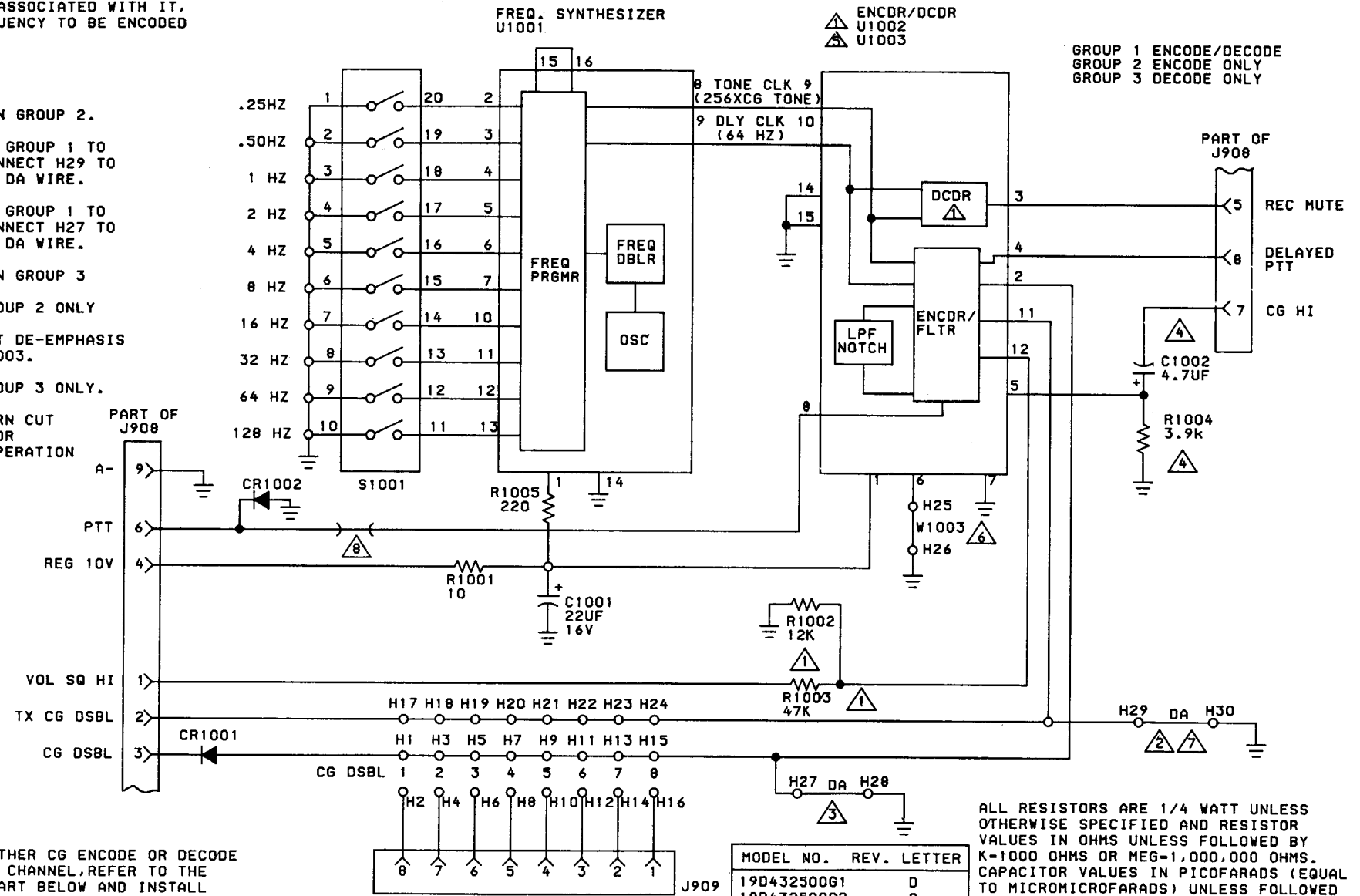

TO DISABLE EITHER CG ENCODE OR DECODE ON A SPECIFIC CHANNEL, REFER TO THE APPROPRIATE CHART BELOW AND INSTALL A DIODE BETWEEN THE HOLES SPECIFIED.

CHANNEL	DECODE DISABLE		ENCODE DISABLE	
	CATHODE ←	→ ANODE	CATHODE ←	→ ANODE
1	H2	H1	H2	H17
2	H4	H3	H4	H18
3	H6	H5	H6	H19
4	H8	H7	H8	H20
5	H10	H9	H10	H21
6	H12	H11	H12	H22
7	H14	H13	H14	H23
8	H16	H15	H16	H24

EXAMPLE:

TO DISABLE CG DECODE, TO MAKE AN "OPEN" CHANNEL, ON CHANNEL 3, INSTALL THE CATHODE OF A DIODE IN HOLE 6, AND THE ANODE IN HOLE 5.

IT IS POSSIBLE TO DISABLE BOTH ENCODE AND DECODE, BY INSTALLING BOTH DIODES.

MODEL NO.	REV.	LETTER
19D432500G1	D	
19D432500G2	C	
19D432500G3	C	

(19C330976, Rev. 7)

GROUP 1 ENCODE/DECODE
 GROUP 2 ENCODE ONLY
 GROUP 3 DECODE ONLY

SCHEMATIC DIAGRAM

CHANNEL GUARD

PARTS LIST

LBI4626A
CHANNEL GUARD EXTENDER BOARD
19C320966G1

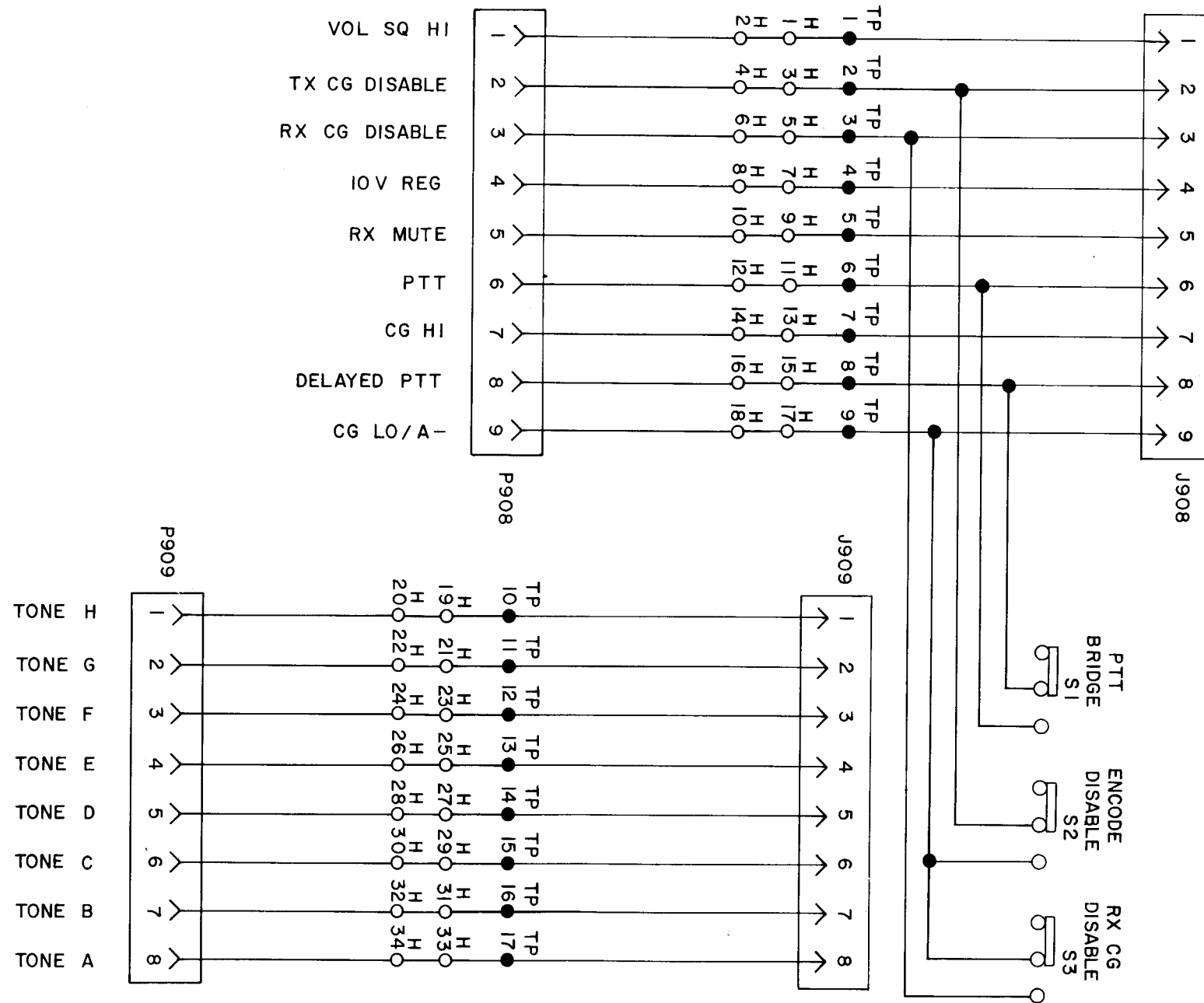

(19C321026, Rev. 1)

SCHEMATIC DIAGRAM

CHANNEL GUARD EXTENDER BOARD

SYMBOL	GE PART NO.	DESCRIPTION
----- JACKS AND RECEPTACLES -----		
J908	19A116659P31	Connector, printed wiring: 9 contacts rated at 5 amps; sim to Molex 09-66-1091.
J909	19A116659P30	Connector, printed wiring: 8 contacts rated at 5 amps; sim to Molex 09-66-1081.
----- PLUGS -----		
Includes:		
P908	19A700102P1	Printed wire: 3 contacts rated at 5 amps; sim to Molex 09-52-3031.
	19A116659P6	Connector, printed wiring: 6 contacts rated @ 5 amps; sim to Molex 09-52-3061.
P909	19A116659P7	Connector, printed wire: 4 contacts rated at 5 amps; sim to Molex 09-51-3041. (Quantity 2).
----- SWITCHES -----		
S1 thru S3	19B209261P14	Slide: DPDT, 2 poles, 2 positions, 1/2 amp VDC or 3 amps VAC at 125 V; sim to Switchcraft 11A-1413.
----- TEST POINTS -----		
TP1 thru TP17	19B211379P1	Spring (Test Point).

*COMPONENTS ADDED, DELETED OR CHANGED BY PRODUCTION CHANGES

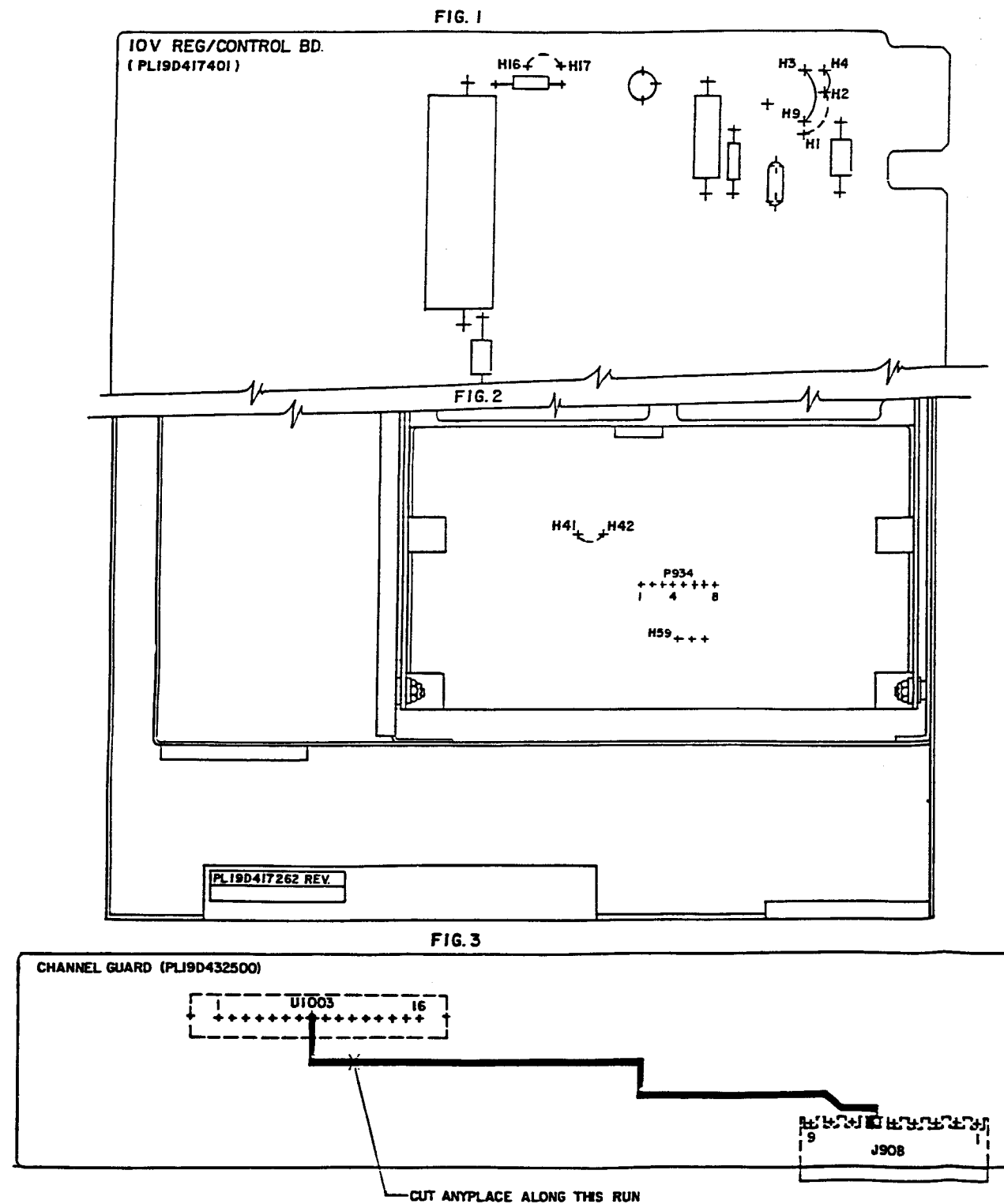

THESE INSTRUCTIONS COVER THE MODIFICATIONS TO THE IOV REG/CONTROL BOARD. (19D417401), DOOR ASSEMBLY (19D417262), & CHANNEL GUARD BOARD (19D432500) FOR USE IN E/D VOICE GUARD STATIONS.

1. ON IOV REGULATOR CONTROL BOARD 19D417401: (SEE FIGURE 1).
 - A. REMOVE END OF JUMPER FROM H1 & INSTALL IN H4.
 - B. REMOVE JUMPER BETWEEN H16 & H17. (OPTIONS 9786, 9787, 9788 ONLY)
2. ON DOOR ASSEMBLY 19D417262 (SEE FIG. 2)
 - A. JUMPER P934-4 TO H59 WITH SLEEVED DA WIRE.
 - B. FOR OPTIONS 9786, 9787 & 9788 ONLY: REMOVE JUMPER BETWEEN H41 & H42.
3. ON CHANNEL GUARD BOARD 19D432500 (SEE FIGURE 3) OMIT THIS STEP IF REMOTE ONLY (FIFTH DIGIT T)
 - A. CUT THE RUN FROM J908-6 TO U3 PIN 8. (OPTIONS 9786, 9787, 9788 ONLY)

MODIFICATION INSTRUCTIONS
In Voice Guard E/D Applications

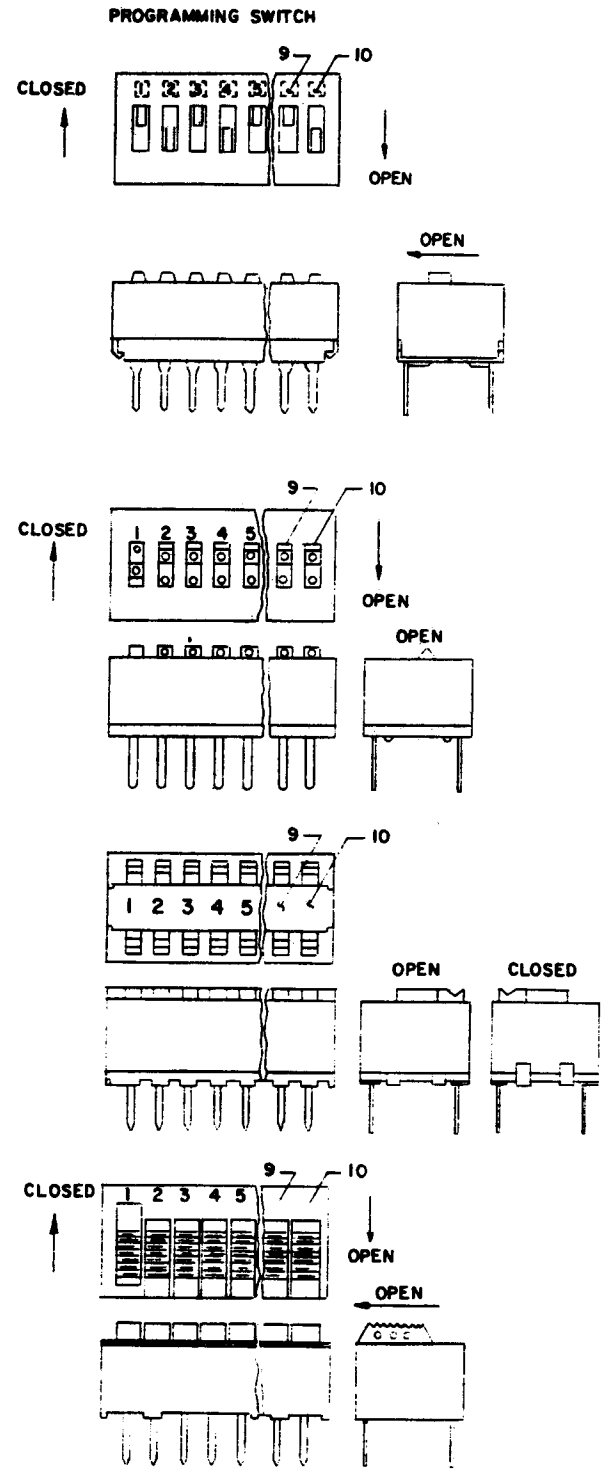

1. TO PROGRAM A STANDARD CHANNEL GUARD FREQUENCY FROM THE CHART, OPEN EACH SWITCH STATION INDICATED BY AN "X", CLOSE EACH SWITCH STATION INDICATED BY A BLANK. SEE FIG 1.
2. TO PROGRAM A NEW STANDARD FREQUENCY, USE THE ± 2 BINARY FORMULA, PLUS THE FRACTIONAL BITS. STATIONS 1-10 REPRESENT BINARY DIGITS FROM 0.25 TO 128. I.E., 0.25, 0.5, 1, 2, 4, ... 128. FOR EACH "ONE" CALCULATED BY THE ± 2 FORMULA, OPEN THE CORRESPONDING SWITCH STATIONS.

FOR EXAMPLE, TO DETERMINE SWITCH SETTING FOR 134.7 Hz.
 SET STATIONS 1, 2 FROM THE FRACTIONAL PART
 CHART SET STATIONS 3-10 BY THE ± 2 FORMULA

	REMAINDER	STATION
134÷2=	67	0
67÷2=	33	1
33÷2=	16	1
16÷2=	8	0
8÷2=	4	0
4÷2=	2	0
2÷2=	1	0
1÷2=	0	1

FIRST DIVISION ALWAYS CORRESPONDS TO SWITCH STATION 3

THUS THE SWITCH SETTING FOR 134.7 Hz IS

1	2	3	4	5	6	7	8	9	10
X	X		X	X					X

WHERE "X" INDICATES AN OPEN STATION.

FRACTIONAL PART CHART		STA.	
FROM	TO	1	2
0.10-0.12			
0.13-0.37		X	
0.38-0.62		X	X
0.63-0.87		X	X
0.88-0.99			

BY INSPECTION, 0.7 IS BETWEEN 0.63 AND 0.87, OPEN STATIONS 1, 2. IF FRACTIONAL PART IS BETWEEN 0.88 AND 0.99, SET STATIONS 1 AND 2 AS ABOVE AND ROUND FREQUENCY UP TO THE NEXT HIGHER INTEGER. (I.E. FOR 179.9 Hz, PROGRAM AS IF FREQUENCY WAS 180 Hz)

FREQ.	SWITCH STATIONS									
	1	2	3	4	5	6	7	8	9	10
67			X	X						X
71.9						X				X
74.4		X		X		X				X
77			X	X		X				X
79.7	X	X	X	X	X	X				X
82.5	X	X		X						X
85.4	X	X	X		X	X				X
88.5	X	X		X		X	X			X
91.5	X	X	X	X		X	X			X
94.8	X	X		X	X	X	X			X
100				X				X	X	X
103.5		X	X	X	X			X	X	X
107.2	X		X	X	X			X	X	X
110.9			X	X	X	X		X	X	X
114.8	X	X		X		X	X	X	X	X
118.8	X	X		X	X	X	X	X	X	X
123.0			X	X		X	X	X	X	X
127.3	X		X	X	X	X	X	X	X	X
131.8	X	X	X	X						X
136.5	X	X				X				X
141.3	X		X		X	X				X
146.2	X			X		X				X
151.4		X	X	X	X	X		X		X
156.7	X	X			X	X	X			X
162.2	X			X				X		X
167.9						X		X	X	X
173.8	X	X	X		X	X	X	X	X	X
179.9					X		X	X	X	X
185.2	X			X		X	X	X	X	X
192.8	X	X							X	X
203.5	X	X	X	X		X			X	X
210.7	X	X		X			X		X	X

C.G. DISABLE STRAPPING, MASTR II SINGLE TONE

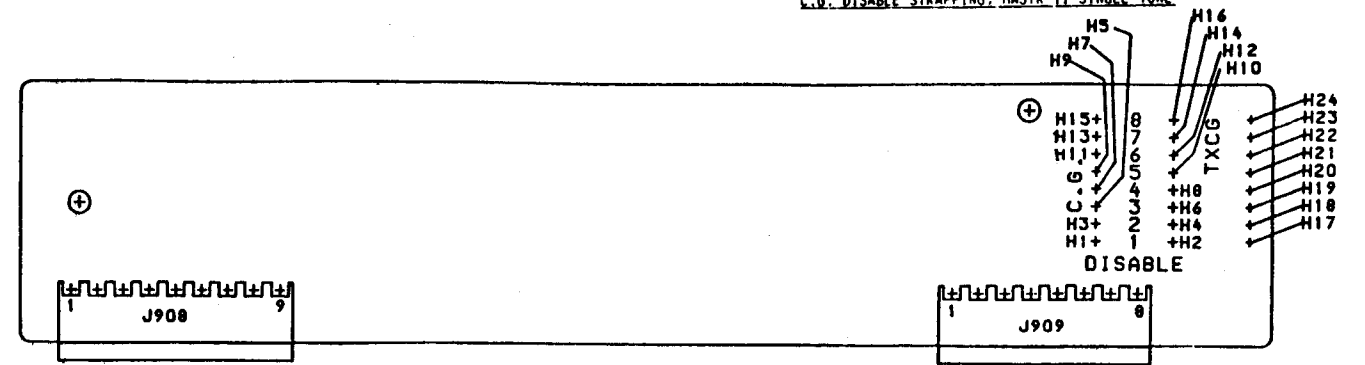

PURPOSE: THIS MODIFICATION IS APPLIED TO MASTR II SINGLE - TONE ENCODE/DECODE CHANNEL GUARD (190432500G1) OR SINGLE ENCODE/DECODE CHANNEL GUARD (190432812G1) OPTION WHICH REQUIRE CHANNEL GUARD DISABLE STRAPPING OR TRANSMIT C. G. DISABLE (PER CUSTOMER REQUEST)

REQUIRED PARTS: 19A115250P1 OR 19A700028P1 DIODES.

INSTALLATION: TO THE PL190432500G1 OR PL190432812 CHANNEL GUARD BOARD PERFORM THE FOLLOWING FUNCTIONS.

1. TO DISABLE EITHER CHANNEL GUARD ENCODER OR DECODER ON A SPECIFIC CHANNEL, REFER TO THE APPROPRIATE CHART BELOW AND INSTALL A DIODE BETWEEN THE HOLES SPECIFIED.

CHANNEL	DECODE DISABLE		ENCODE DISABLE	
	CATHODE →	← ANODE	CATHODE →	← ANODE
1	H2	H1	H2	H17
2	H4	H3	H4	H18
3	H6	H5	H6	H19
4	H8	H7	H8	H20
5	H10	H9	H10	H21
6	H12	H11	H12	H22
7	H14	H13	H14	H23
8	H16	H15	H16	H24

EXAMPLE: TO DISABLE CHANNEL GUARD DECODE, TO MAKE AN "OPEN" CHANNEL, ON CHANNEL 3, INSTALL THE CATHODE OF A DIODE IN HOLE 6, AND ANODE IN HOLE 5.

IT IS POSSIBLE TO DISABLE BOTH ENCODE AND DECODE, BY INSTALLING BOTH DIODES.

(19C321875, Sh. 5, Rev. 1)