



MLS MAINTENANCE MANUAL LBI-31764A

TABLE OF CONTENTS

EXITER/POWER AMPLIFIER	LBI-31765
RECEIVER BOARD	LBI-31766
CONTROL/SYNTHESIZER	LBI-31767
FRONT PANEL/CONTROL UNIT	LBI-31756
SERVICE SECTION	LBI-31768

NOTE: The above LBIs are filed separately.

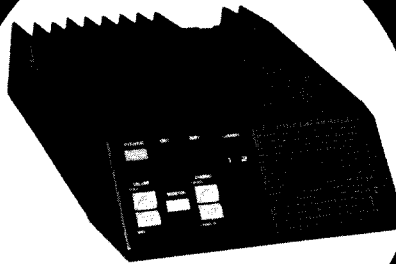

MLSH040

150.8 - 174.0 MHz
 40 WATTS
 TWO-WAY FM
 MOBILE RADIO
 COMBINATION

TABLE OF CONTENTS

	<u>Page</u>
SPECIFICATIONS	iii
COMBINATION NOMENCLATURE	iv
DESCRIPTION	1
OPERATION	
Controls	3
Indicators	4
Using the Radio	4
Scan Operation	6
To Program Scan Channels and Select Priority	7
Using The Optional Eight (8) or Sixteen (16) Channel Radio (With Scan)	8
MAINTENANCE	9
INTERCONNECTION DIAGRAM (DDOO-JHM252S40)	10
ILLUSTRATED MECHANICAL PARTS BREAKDOWN	11
INTERCONNECTION KIT (JHM-252S40)	12

ILLUSTRATIONS

Figure 1 - Mobile Layout Diagram	2
Figure 2 - Standard Two (2) Channel Radio	4
Figure 3 - Eight (8) Channel Radio (Without Scan/With Scan)	5
Figure 4 - Sixteen (16) Channel Radio (Without Scan/With Scan)	5

CAUTION

Although the highest DC voltage in this mobile equipment is supplied by the vehicle battery, high currents may be drawn under short circuit conditions. These currents can possibly heat objects such as tools, rings, watchbands...etc., enough to cause burns. Be careful when working near energized circuits!

High-level RF energy in the transmitter Power Amplifier assembly can cause RF burns upon contact. Keep away from these circuits when the transmitter is energized!

NOTE

This equipment has been tested and found to comply with the technical specifications in Part 15, subpart J of the FCC rules for a Class A and Class B computing device.

SPECIFICATIONS*

SYSTEM

<u>Radio Type</u> FCC#	MLSH040
<u>Frequency Range:</u>	
Transmitter	150.8 to 174 MHz
Receiver	150.8 to 174 MHz
Transmitter	Two Frequency Spread 6 MHz
Receiver	Two Frequency Spread 3 MHz
<u>Battery Drain:</u>	
Receiver (13.8 VDC)	
Off	0.03 Amperes
Squelched	0.70 Amperes nominal
Unsquelled	1.15 Amperes (4 Watts audio)
Transmitter (13.6 VDC)	14.0 Amperes (40 Watts RF)
<u>Frequency Stability</u>	+5 ppm
<u>Channel Spacing</u>	30 KHz
<u>Frequency Capacity</u>	16 Channels maximum
<u>Temperature Ranager</u>	-30°C (-22°F) to +60°C (+140°F)
<u>Duty Cycle</u>	80% Receive, 20% Transmit
<u>Dimensions</u> (H X W X D) (Less Accessories)	5.5 cm X 18.5 cm X 24 cm
<u>Weight</u> (Less Accessories)	2.7 kg

TRANSMITTER

<u>Power Output</u>	40 Watts
<u>Conducted Spurious</u>	FCC
<u>Modulation</u>	+5.0 KHz
<u>Audio Sensitivity</u>	20 to 70 millivolts
<u>Audio Frequency Characteristics</u> (Per RS-125B)	Within + 1 dB to -3 dB of 6 dB/octave pre-emphasis from 300 Hz to 2500 Hz per EIA standard and ± 1 dB to -4.5 dB at 3000 Hz
<u>Distortion</u>	Less than 3% (1000 Hz) Less than 5% (300 Hz to 3000 Hz)
<u>Deviation Symmetry</u>	0.5 KHz (maximum)
<u>RF Output Impedance</u>	50 ohms
<u>Carrier Attack Time</u>	30 milliseconds (maximum)
<u>Audio Attack Time</u>	50 milliseconds (maximum)

RECEIVER

<u>Audio Ampl Output</u> (4-ohm speaker)	4 Watts (less than 5% distortion) EIA
---	---------------------------------------

<u>Sensitivity:</u>	
12 dB SINAD (EIA method)	0.35 microvolts
20 dB (Quieting method)	0.40 microvolts
<u>Selectivity</u> (EIA two-signal method)	-70 dB \pm 30 KHz
<u>Spurious Response</u>	-70 dB
<u>Intermodulation</u>	-70 dB
<u>Modulation Acceptance</u>	\pm 7 KHz
<u>Frequency Response</u>	Within +2.0 dB and -8 dB of a standard 6 dB/octave de-emphasis curve from 300 Hz to 3000 Hz EIA
<u>RF Input Impedance</u>	50 ohms
<u>Receiver Attack Time</u>	90 milliseconds, typical 150 milliseconds, maximum
<u>Receiver Recovery Time</u>	100 milliseconds, typical 250 milliseconds, maximum

COMBINATION NOMENCLATURE

DIGITS 1 & 2	DIGIT 3	DIGIT 4	DIGIT 5	DIGIT 6 & 7
Product Code	Radio Type	Frequency Band	Frequency Split	RF Power Output
ML	S Synthesized	H High Band	O None	40 40 Watts

These specifications are intended primarily for the use of service personnel. Refer to the appropriate Specification Sheet for the complete specifications.

DESCRIPTION

The General Electric MLS series mobile radio is a synthesized, wideband radio, utilizing microcomputer technology to provide high reliability, high quality and high performance in two-way, FM, mobile communications. The radios operate in the 150.8 to 174 MHz frequency ranges and provide an RF power output of 40 watts with an allowable channel separation of 6 MHz transmit and 3 MHz receive. The channel separation does not apply in repeater talk-around applications because the transmit and receiver frequencies are the same.

The small size of the MLS makes it ideal for front mounting in conventional vehicles, with all operating controls and indicators located on the front panel. The standard radio combination is equipped with the following:

- Microcomputer control
- RF channel synthesizer
- Up to 16 RF channels
- LED channel display
- Channel Guard (CTCSS)
- Carrier Control Timer (CCT)
- $\pm 0.0005\%$ (5 PPM) frequency stability

The radio circuitry consists of a System Control/Frequency Synthesizer Board (A801), a Receiver Board (A802), a Power Amplifier Board (A803) and a Front Panel/Control Unit (A804 and A804-1).

The circuitry also consists of Control Indicator Panel (A804), an internal speaker, an antenna jack, a connector for the microphone and a power supply cable (refer to Figure 1 - Mobile Layout Diagram).

No power supply is used since the highest supply voltage required for the operation of the radio is provided by the vehicle battery. The radio is designed for operation in a 12-volt, negative ground vehicular system or as an AC powered mobile.

Access to each circuit board is easily achieved by loosening four (4) screws in the rear of the top and bottom covers then removing each cover. All tuning controls are also accessible with the covers removed.

Access to the Control and Indicator circuitry can be achieved by removing the

four (4) screws securing the front panel to the chassis.

Exciter/PA Board

The Exciter/PA board consists of a broadband, fixed-tuned driver module and a power amplifier.

The RF power output level is internally adjustable for rated power output. Once the level is set, a sensing control circuit holds the power constant over the temperature and/or voltage variations within specified limits.

Receiver Board

The dual conversion receive circuit consists of a front end section and two mixer/IF sections operating at 82.2 MHz and 455 KHz. The receive circuit also contains a squelch and audio section. The audio section provides a 4-Watt audio output into a 4-ohm load (internal speaker or external speaker).

Frequency Synthesizer

The synthesizer drives the transmit circuit exciter and the receive circuit first mixer and consists of a synthesizer chip, a prescaler, a reference oscillator and the voltage controlled oscillators (VCO's). The synthesized frequency is controlled by the personality EEPROM and applied to the exciter/PA and receiver boards.

An Electrically Erasable PROM (EEPROM), on the System Control and Frequency Synthesizer Board (A801) stores the binary data for the transmit and receive frequencies, Channel Guard tones and CCT timing periods. The EEPROM is field programmable and each channel can be individually programmed or re-programmed for the desired transmit and receive frequencies, CG tones or CCT timing.

Control Panel

The Control Panel (A804) consists of the front panel housing, an internal speaker and a plug-in module (A804-1) which determines the number of channels (2 to 16) and mode of operation (with or without scan). Refer to Maintenance Manual LBI-31756, listed in the Table of Contents of this publication. The panel is made of highly durable plastic with rounded corners and recessed controls and indicators for passenger safety requirements (refer to the OPERATION section for a description of the Control and Indicator functions).

There are four (4) different optional interchangeable control panels available for upgrading a standard two channel radio to an eight (8) or sixteen

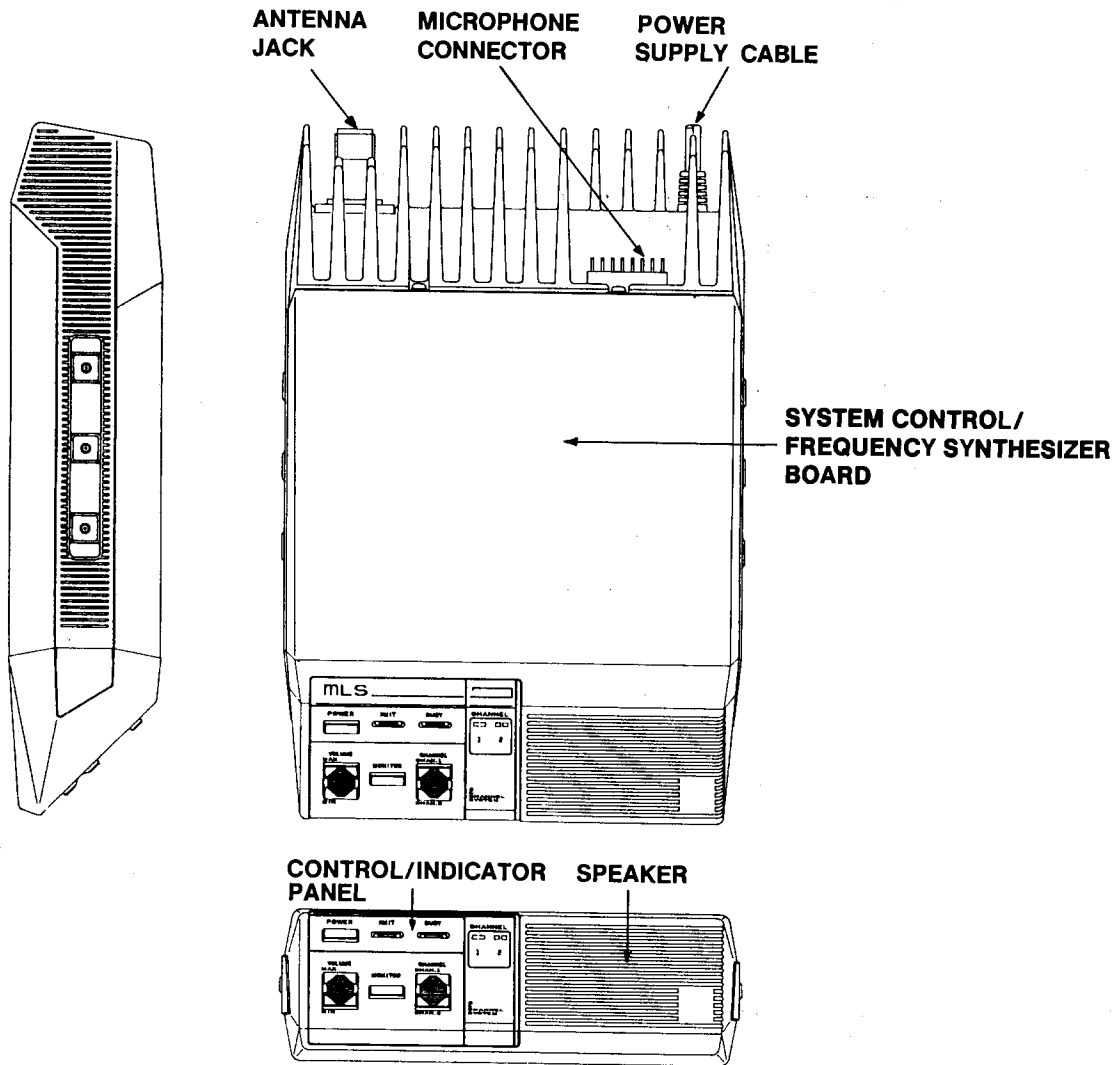

RC-5417B

Figure 1 - MLS VHF Mobile Two-Way FM Radio

(16) channel radio. The four control panels are as follows:

- Option MK02: Eight (8) Channel Without Scan (19A704991P101)
- Option MK03: Eight (8) Channel With Scan (19A704991P102)
- Option MK04: Sixteen (16) Channel Without Scan (19A704991P103)
- Option MK05: Sixteen (16) Channel with Scan (19A704991P104)

Microphone

The mobile radio uses a dynamic microphone with a built-in transistorized pre-amplifier. The microphone is housed in a sturdy case and the extendable coiled cord plugs into a jack provided at the back of the radio. The microphone is secured to the radio by means of a strain relief hook on the microphone cable.

Hookswitch

A hookswitch is provided with the radio to hold the microphone. Removing the microphone from the hookswitch disables the Channel Guard, enabling the operator to monitor the channel before sending a message. Removing the microphone while in the SCAN mode, will also disable SCAN until the microphone is placed back into the hookswitch.

Channel Guard

Channel Guard provides a means of restricting calls to specific radios through the use of a continuous tone coded squelch system (CTCSS). Tone frequencies range from 67.0 Hz to 210.7 Hz. The Channel Guard tone frequencies are software programmable and are listed in the Programmer's Manual LBI-31717.

Carrier Control Timer

The Carrier Control Timer turns off the transmitter after the microphone push-to-talk (PTT) switch has been keyed for a pre-programmed time period. The timer can be programmed to time out and sound an alert tone in 30 second increments up to 7.5 minutes.

External Speaker (Optional)

An optional 4-Watt, 4-ohm external speaker is available for use with the radio. The speaker is supplied with a mounting bracket and mounting hardware. The speaker leads connect through connector J701 on the back of the radio (refer to Installation Manual LBI-31694).

Programming

The radio is field programmable using Universal Radio Programmer (URP) TQ2310. Programming is accomplished by connecting the URP to the radio using the programming cable TQ2347. The programmer connects through cable TQ2347 to microphone connector J701 at the back of the radio (refer to Programming Manual LBI-31717).

OPERATION

This section provides a description of the Control and Indicator functions as well as the basic procedures for transmitting and receiving messages. Complete operating instructions for the radio are provided in Operator's Manual LBI-31693.

CONTROLS

The radio control panel contains the VOLUME control, the POWER on/off switch, the MONITOR switch and the CHANNEL select switch. The switch functions are as follows:

POWER A momentary type switch to turn the radio on or off. Press once to turn the radio on; press again to turn the radio off. Power ON is indicated by an illuminated channel number on the system module.

VOLUME Two momentary type switches to adjust the volume. Press and hold the MAX (up arrow) to increase the volume. Press and hold the MIN (down arrow) to decrease the volume.

MONITOR A momentary type switch to allow you to monitor the selected channel before transmitting a message. It disables Channel Guard and squelch and will allow you to hear noise if the channel is not busy. This may be convenient when setting the volume to the desired listening level.

CHANNEL Two momentary type switches. Press CHAN 1 (up arrow) to select channel 1; press CHAN 2 (down arrow) to select channel 2. The selected channel number will be illuminated on the control module.

With an eight or sixteen channel radio two momentary type switches select channels

electronically. Press and hold the ADD switch to increase the channel number; press and hold the DELETE switch to decrease the channel number. The selected channel is displayed by a 7-segment display.

- ADD** When used in conjunction with the SCAN switch, adds channels to the scan list.
- DELETE** When used in conjunction with the SCAN switch, deletes channels from the scan list.
- SCAN** A momentary type switch to turn the scan function on or off. When used in conjunction with the CHANNEL switch it enables the ADD/DELETE function to allow the scan list to be modified. When turned on, the scan indicator is illuminated.

INDICATORS

- XMIT** Lights when your message to (transmit) being transmitted.
- BUSY** Lights when the channel is in use.

CHANNEL Lights to indicate which channel has been selected.

- 1** When lit, indicates that the channel displayed is a Priority 1 scan channel.
- 2** When lit, indicates that the channel displayed is a Priority 2 scan channel.
- S** When lit, indicates that the channel displayed is a non-priority scan channel.

SCAN When lit, indicates that the radio is operating in the scan mode.



The channel indicator displays the following conditions:

- When scan is off, the selected channel is shown.
- When scan is on, the last pre-scan selected channel is shown when no signal is being received. When a scan channel is being received and audio is present in the speaker, the received channel is shown.

STANDARD TWO (2) CHANNEL RADIO

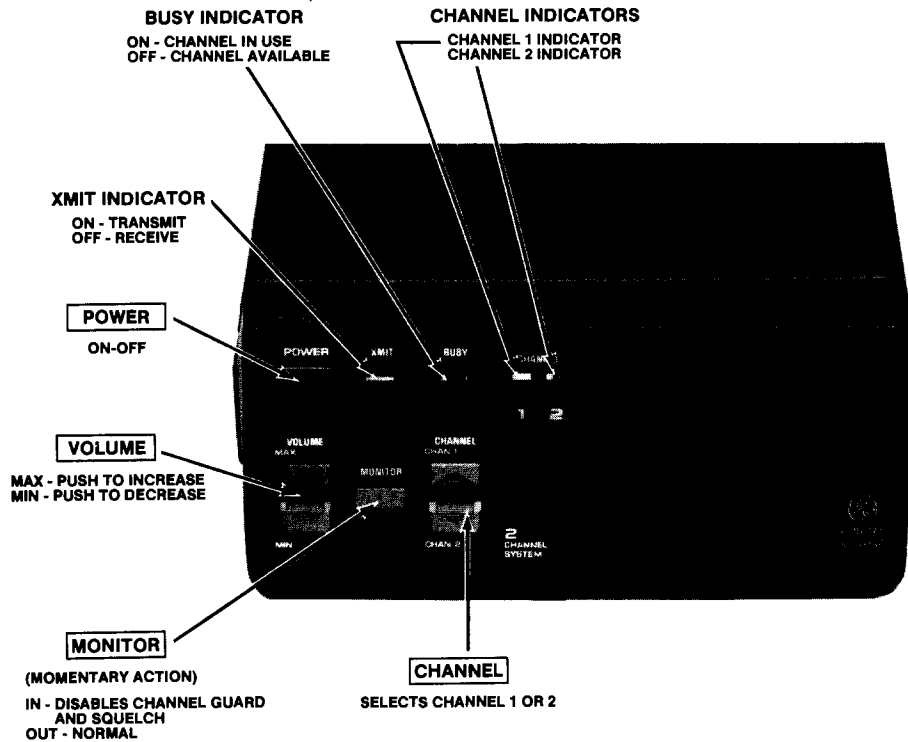

Figure 2 - Standard Two Channel Radio

THE OPTIONAL EIGHT (8) OR SIXTEEN (16) CHANNEL RADIO

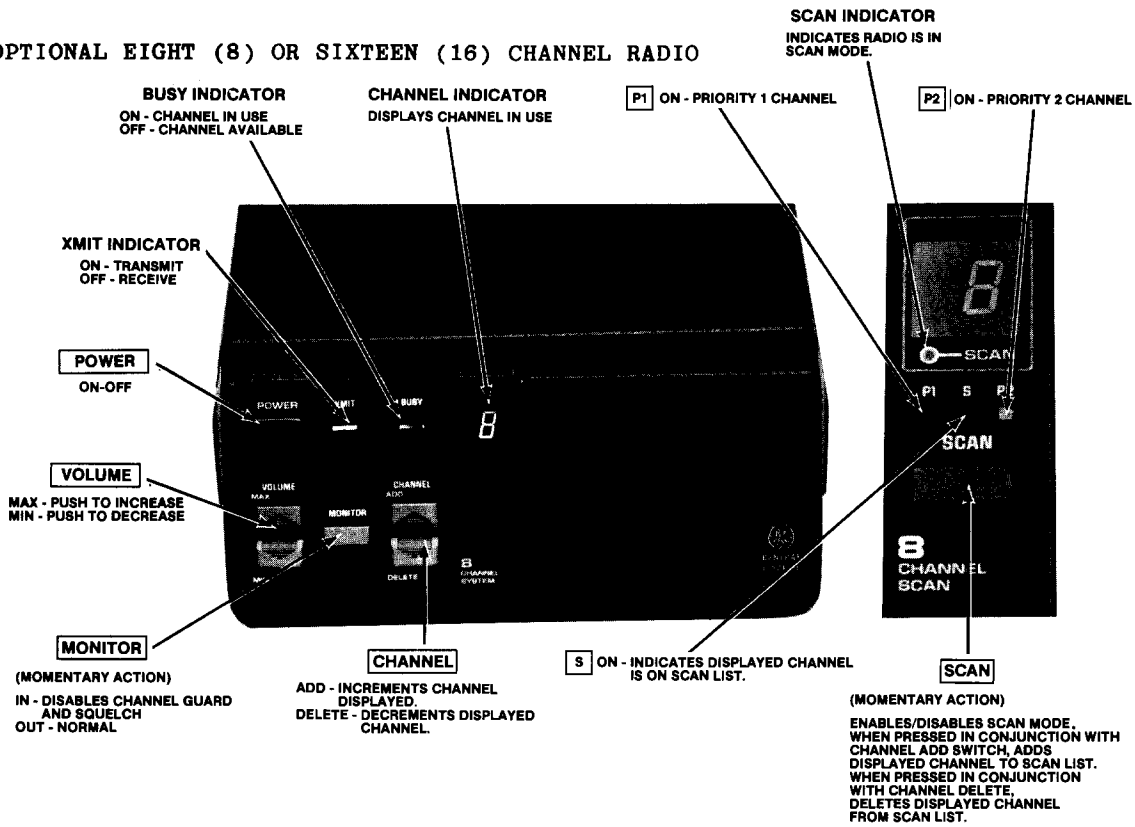

Figure 3 - Eight Channel Radio Without Scan/With Scan

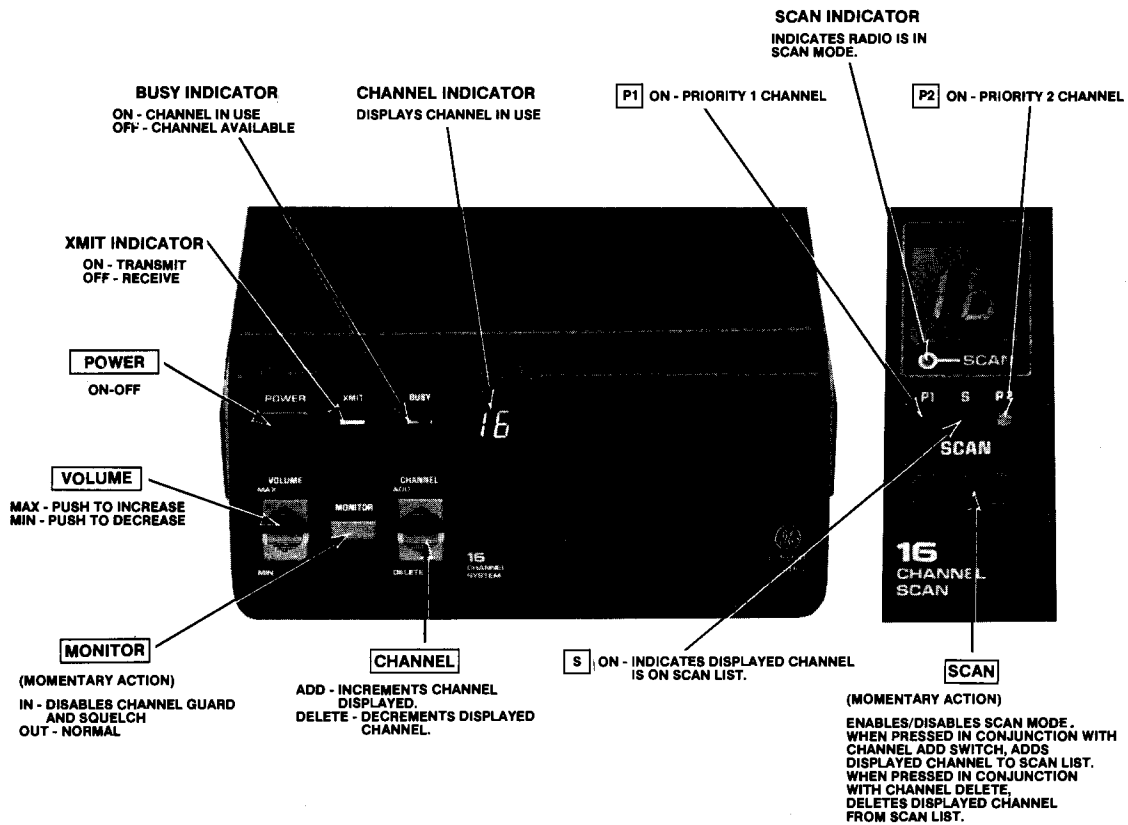

Figure 4 - Sixteen Channel Without Scan/With Scan

Using the Radio

To Receive A Message:

1. Turn the radio on (channel indicator lit). If not, press POWER switch.
2. Select the desired channel by pressing either the 1 or 2 switch.
3. Press and hold MONITOR switch and then adjust VOLUME controls for the desired listening level. Release MONITOR switch.
4. Radio is now ready to receive a message.

To Transmit A Message:

1. Confirm that the radio is turned on (channel indicator lit). If not, press POWER switch.
2. Select the desired channel by pressing either the 1 or 2 switch.
3. Press and hold MONITOR switch and then adjust VOLUME controls for the desired listening level. Release MONITOR switch.
4. Decide what you want to say. If you intend a lengthy message (or several messages) the vehicle engine should be running to maintain the battery charge.
5. Observe the BUSY indicator and press the MONITOR switch to assure that the channel is not in use.
6. Remove microphone from hookswitch, press the PTT switch and identify yourself. The XMIT indicator will light each time the PTT switch is pressed.
7. Release the PTT switch and wait for an answer to your call. Then, complete your message.

NOTE

Always speak in a normal voice. Hold the microphone cupped in your hand and touching your cheek lightly. Speak across the face of your microphone, not directly into it. Shouting will actually reduce your radio range, so do not speak any louder than normal.

USING THE OPTIONAL EIGHT (8) OR SIXTEEN (16) CHANNEL RADIO (WITHOUT SCAN)

To Receive a Message:

1. Turn the radio on (channel indicator lit). If not, press POWER switch.
2. Select the desired channel by pressing either the ADD or DELETE switch.
3. Press and hold MONITOR switch and then adjust the VOLUME controls for the desired listening level. Release MONITOR switch.
4. Radio is now ready to receive a message.

To Transmit A Message:

1. Confirm that the radio is turned on (channel indicator lit). If not, press POWER switch.
2. Select the desired channel by pressing either the ADD or DELETE switch.
3. Press and hold MONITOR switch and then adjust the VOLUME controls for the desired listening level. Release MONITOR switch.
4. Decide what you want to say. If you intend a lengthy message (or several messages) the vehicle engine should be running to maintain the battery charge.
5. Observe the BUSY indicator and press the MONITOR switch to assure that the channel is not in use.
6. Remove the microphone from the hookswitch, press the PTT switch and identify yourself. The XMIT indicator will light each time the PTT switch is pressed.
7. Release the PTT switch and wait for an answer to your call. Then, complete your message.

SCAN OPERATION

The SCAN function allows monitoring of up to eight or sixteen receive channels (depending upon which control module is being used). The scanned channels may be any frequency within the frequency band limits of the radio and may be Channel Guard protected. The radio message will then be received only if the correct Channel Guard signal is present.

Any channel may be scanned with or without priority level. One channel may be programmed for Priority 1 (P1) and

another for Priority 2 (P2) with any or all remaining programmed channels being scanned as non-priority (S).

Receive Scan Rate

The scan rate for the radio will vary depending upon the number of channels programmed into the scan memory and whether or not Channel Guard is programmed. For a sixteen channel radio the scan rate will vary from 1.1 to 4.4 seconds for non-priority channels and 0.3 to 1.2 seconds for Priority 1 and 2 channels. The scan rate will be faster when fewer channels are programmed into scan memory.

Scan operation will be determined by the following conditions:

- Priority 1, Priority 2 and Non-Priority Programmed*

The Priority 1, Priority 2 and up to six (6) remaining channels in an eight (8) channel radio or fourteen (14) channels in a sixteen (16) channel radio will be scanned. Once a carrier is detected (or correct Channel Guard tone is decoded) the digital display will indicate the channel. Sampling of the Priority 1 and Priority 2 channels continues while receiving a message on a non-priority channel. Should a Priority 1 or Priority 2 channel carrier (and correct Channel Guard) be detected while a non-priority channel is being received, the applicable indicator (P1 or P2) lights and the channel is switched to the Priority 1 or 2 channel, regardless of what is being received on the non-priority channel.

If a Priority 2 channel is detected, sampling of the Priority 1 channel continues. Once a carrier (and correct Channel Guard) is detected on the Priority 1 channel, the channel is switched to the Priority 1 channel regardless of what is being received on another channel (Non-priority or Priority 2). No sampling occurs

during transmit or if a Priority 1 channel is receiving.

- Non-Priority Programmed:

Up to eight/sixteen (8/16) non-priority channels may be scanned. Once a carrier is detected (or correct Channel Guard tone is decoded) the digital display will indicate the channel. Scan will stop and remain on the channel until the carrier disappears; after a few seconds scanning resumes. The channels will be scanned in descending order.

Transmit In Scan Mode:

Several characteristics in the transmit mode occur if the radio has been placed in the scan mode of operation.

- Radio is in scan mode but there is no carrier activity to stop the scan on any channel. Removing the microphone from its hookswitch will stop the scanning activity and the radio will revert to the pre-scan selected channel. Replacing the microphone will enable the scan mode after a few seconds delay.
- Radio is in scan mode and carrier activity on a channel has caused scan to stop. Removing the microphone from its hookswitch will keep that channel selected. When push-to-talk (PTT) is pressed on the microphone, the transmit channel will be the displayed channel. The channel can be changed during this time as needed but will be forgotten when scanning resumes. Placing the microphone back on the hookswitch will cause scan to resume, after a few seconds delay.
- The Channel Guard decode is disabled whenever the microphone is removed from its hookswitch.
- During the scan mode the MONITOR and CHANNEL selection functions are disabled if scan is not stopped on a channel.

* The rate the P1 and P2 channels are sampled while listening to a non-priority channel depends whether RF carrier is present or not. If no carrier is present on P1 or P2, the scan rate is fast. If carrier is detected but incorrect Channel Guard is present, the rate slows considerably. This prevents the non-priority signal from being badly distorted by the larger mute times needed to detect Channel Guard. If Channel Guard is not programmed for P1 or P2 the scan sampling rate remains fast.

TO PROGRAM SCAN CHANNELS AND SELECT PRIORITY

The selection of scan channels and priority is front panel programmable using the SCAN switch in conjunction with the ADD and DELETE switch.

Non-Priority:

1. Confirm that radio is turned on (channel number is lit). If not, press the POWER switch.
2. If SCAN indicator is lit, press and release the SCAN switch to disable scan function.
3. Select desired channel using the ADD or DELETE switch.
4. Press and hold SCAN switch, then press the ADD switch once to add the channel to the scan list. The "S" indicator will light to indicate that the channel is now in the scan program.
5. Release SCAN switch.
6. Repeat steps 2 thru 5 for each channel (up to 8/16) to be added to the scan list.

Priority 2 (P2)**:

1. Perform steps 1 thru 3 of the Non-Priority procedure.
2. Press and hold SCAN switch; then press the ADD switch twice. The selected channel will now become the Priority 2 channel and the "P2" indicator will light to indicate that the channel is now in the scan program as Priority 2.
3. Release SCAN switch.

Priority 1 (P1)**:

1. Perform steps 1 thru 3 of the Non-Priority procedure.
2. Press and hold SCAN switch; then press the ADD switch three times. The selected channel will now become the Priority 1 channel and the "P1" indicator lights to indicate that the channel is now in the scan program as Priority 1.
3. Release SCAN switch.

Delete Scan Channels (S, P1, P2)

1. Confirm that radio is turned on (digital display lit). If not, press POWER switch.
2. If SCAN indicator is lit, press and release SCAN switch to disable scan function.
3. Select the desired channel to be removed from the scan list using the ADD or DELETE switch.
4. Press and hold SCAN switch; then press the DELETE switch once. This removes the selected channel from the scan list. All scan indicators (S, P1, P2 and SCAN) will be off.
5. Release SCAN switch.
6. Repeat preceding steps 2 thru 5 for each channel to be removed from the scan list.

Review

1. Confirm that radio is turned on (channel indicator lit). If not, press POWER switch.
2. If SCAN indicator is lit, press and release SCAN switch to disable scan function.
3. Select each channel (one at a time) using the ADD or DELETE switch and confirm channels included on the scan list. The scan indicator (S, P1, P2) will light for each channel programmed.

USING THE OPTIONAL EIGHT (8) OR SIXTEEN (16) CHANNEL RADIO (WITH SCAN)

Perform the procedure listed in the paragraph "Using the Optional Eight (8) or Sixteen (16) Channel Radio (Without Scan)."

Scan Mode

Press and release SCAN switch to enable the scan function. The scan indicator should light and the following condition apply:

- Only programmed scan channels will be received.

** If a Priority 1 or 2 scan channel already exists when programming a new Priority 1 or 2 scan channel, the old Priority 1 or 2 channel becomes a Non-Priority scan channel.

- As long as no signal is being received, the digital display will indicate the pre-scan selected channel. If S, P1 or P2 indicator is not lit, no signal will be received on this channel, since it has not been programmed for scan.
- When a signal is received the display indicates the channel received and the priority level.
- Removing microphone from hook-switch locks the radio onto the received scan channel. Pressing the PTT switch on the microphone allows transmission on the received scan channel.
- Scan resumes, after a few seconds delay, when the microphone is returned to the hook-switch. Pre-scan channel will again be displayed and will be the transmit channel if user removes microphone from hook-switch before another channel is detected.
- Channel changes and other normal operations are allowed while off-hook, but will be immediately forgotten when the microphone is placed on-hook.

MAINTENANCE

Maintenance Information for the VHF MLS mobile radio is provided in Service Section Manual LBI-31768, listed in the Table of Contents of this publication. The Service Section Manual includes information as follows:

- Disassembly Procedures
- Transmit Alignment Procedures
- Receiver Alignment Procedures
- Receiver Test Procedures
- Troubleshooting Procedures
- Test Point Voltage Readings
- Receiver Voltage Reading
- IC and Chip Component Replacement Procedures

Also, provided in the Maintenance Manuals for each circuit board are IC DATA SHEETS with information about each IC package used on that particular circuit board.

GENERAL ELECTRIC COMPANY • MOBILE COMMUNICATIONS DIVISION
WORLD HEADQUARTERS • LYNCHBURG, VIRGINIA 24502 U.S.A.

GENERAL  ELECTRIC*
U.S.A.

* Trademark of General Electric Company U.S.A.
Printed in U.S.A.

Notes:

⚠ When using DTMF Microphone (Mfg. by Astatic), carefully cut printed run on component side of Systems Control 1/Synthesizer Board CMC-404 at J701-1 thus isolating J701-1 from the printed board. Solder a #24 wire from J701-1 to the output of the 9v. regulator IC207. The output is the pin nearest C248. This will provide the +9v. needed for pin 1 of the DTMF microphone.

If an external speaker is desired with the DTMF microphone, cut the wires from the internal speaker and run the cut ends through the opening around J701 at rear of the radio. Add a connector to these cut wires and a mating connector to the external speaker wires. Strain relieve the cable to J701-8 inside the radio.

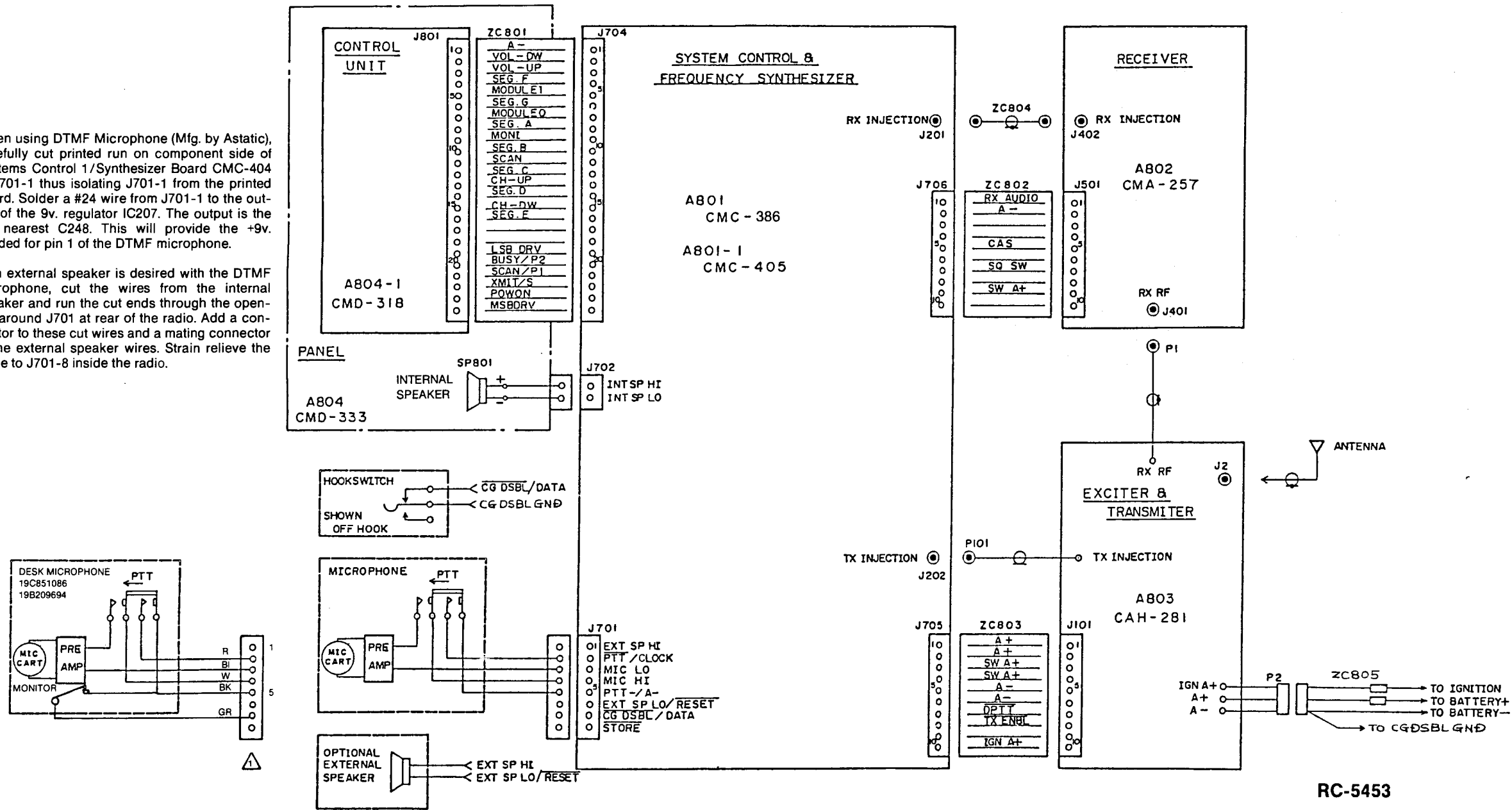

INTERCONNECTION DIAGRAM

DD00-JHM252S40

PARTS LIST

LBI-31749
MECHANICAL PARTS

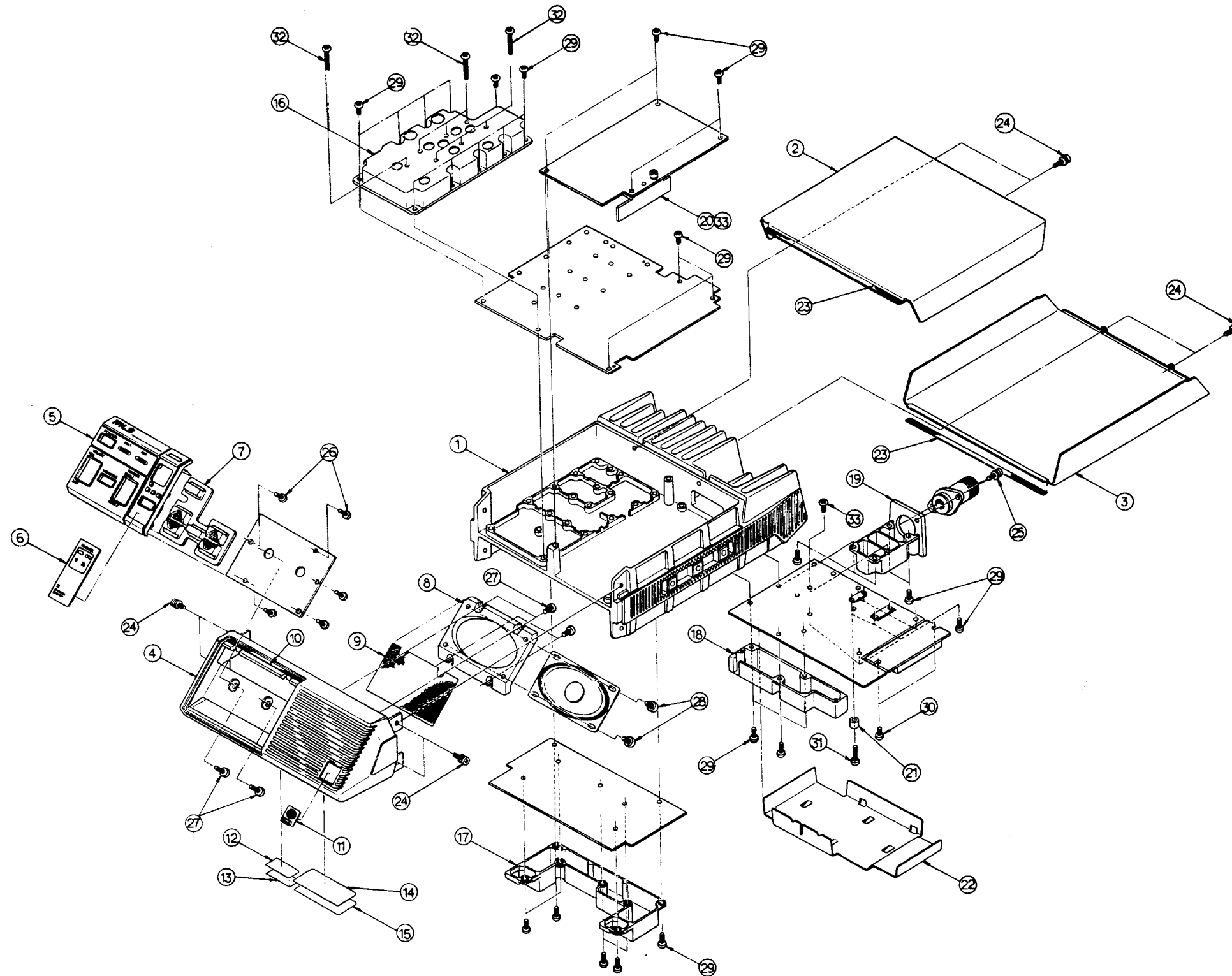

SYMBOL	GE PART NO.	DESCRIPTION
1	MTC002453A	Cabinet Center Section
2	MTB147733	Cabinet Top Cover
3	MTB147734	Cabinet Bottom Cover
4	MTV002874	Cabinet Front
5	MTV002878	Control Insert (A Option)
6	MTV002880A	Display Insert (A Option)
7	MTV002876	Control Knob 1
8	MTV002875	Mounting Base for Sp.
9	MTZ002808	Baffle Cloth
10	MTZ002816	Cloth
11	MPNL16972	Co. Signature Medallion
12	MPNL19260	Shipping Label
13	MPNL19264	Overlay
14	MPNL19257 (MLSU140)	Nameplate
	MPNL19258 (MLSU240)	Nameplate
15	MPNL19263	Overlay
16	MTC002459	Shield Case
17	MTC002458	Shield Case
18	MTC002456	Shield Case
19	MTC002457	Shield Case
20	MTB151938A	Mounting Plate
21	MTL035255	Spacer
22	MTB149977A	Shield Cover
23	MTZ002818A	Damper Cloth
24	BRTG03432	Screw
25	BRTG03433	Screw
26	BRTG03159	Screw
27	BRTG03095	Screw
28	BRTG03429	Screw
29	BRTG01226	Screw
30	BRTG03486	Screw
31	BRTG03434	Screw
32	BRTG03436	Screw
33	BRTG03485	Screw

*COMPONENTS ADDED, DELETED OR CHANGED BY PRODUCTION CHANGES

PARTS LIST

INTERCONNECTION KIT
JHM-252840
ISSUE 3

SYMBOL	GE PART NO.	DESCRIPTION
A801	JRC/CMC-386	SYSTEM CONTROL 1/SYNTHESIZER BOARD
A801-1	JRC/CMC-405	SYSTEM CONTROL 2 BOARD
A802	JRC/CMA-257	RECEIVER BOARD
A803	JRC/CAH-281	TRANSMITTER BOARD
A804	JRC/H-CMD-333	FRONT PANEL
ZC802 and ZC803	JRC/5ZCCL00027	FLEXIBLE RIBBON CABLE
ZC804	JRC/6JJFD00078	CO-AXIAL CABLE
ZC805	JRC/6ZCFD00166	POWER CABLE
		- - - - - ASSOCIATED PARTS - - - - -
	19B801398P1,2	Microphone

PARTS LIST CHANGES

The prefix of Service Parts replacement part numbers listed in the various Parts Lists included in this maintenance manual have been changed from "JRC/" to "B19/". All other characters remain the same as displayed. When this manual is next reprinted, all replacement parts lists will show only the "B19/" prefix.

When ordering replacement parts listed in this manual from the GE Mobile Communications Service Parts Operation, please use only the "B19/" prefix. The "B19/" prefix will be the only one shown in any future SERVICE PARTS PRICE LIST.