

TQ0609 TEST BOX

TABLE OF CONTENTS

DESCRIPTION.....	Page
TQ0609A VERSION.....	1
TESTING.....	2
TEST POINTS	3
PARTS LIST.....	4
PARTS LIST - REV. A.....	4
SCHEMATIC DIAGRAM.....	5
SCHEMATIC DIAGRAM - REV. A.....	6
LAYOUT DIAGRAM.....	7
LAYOUT DIAGRAM - REV. A.....	7

DESCRIPTION

The TQ0609 test box is used to test personal radios that use the MPD type options that connect to the radio's Universal Device Connector (UDC). These radios include the M-RK, MPD, TPX, MPD Voice Guard, and the EDACS™ MPD personal radios. To test, adjust, and troubleshoot the transmitter of the personal radio, it is necessary to apply an audio signal into the transmitter and key the radio. The test box provides a way to input the audio signals, and key the radio as well as provides the points to test the other connections of the UDC. Together with the K19/A4WX01543 Dummy Battery/Speaker Load, the test box can be used to test the radio to see if any problem exists or to troubleshoot the radio by providing inputs and outputs for the shop test equipment. For more information on testing and troubleshooting land mobile radios, see the Test and Troubleshooting (T&T) Handbook (ECP-165).

Whenever the radio is turned on, it checks the resistance of the UDC lead (E9) of the UDC to A-. That resistance will determine the option that is connected to the radio. The UDC switch of the test box will select the different resistors to simulate the options. The following chart shows the resistors values and the associated options. Notice that the 3160 ohm resistor is not installed. If it is installed it can be put in any of the unused positions.

UDC Pos.	Resistor Value Ω	Option Description
1	0	Programmer--Radio will go into the programming mode.
2	3740	Speaker Mic (Standard--SW Bat is used as mute lead)
3	4420	Earphone
4	5360	Vehicular Charger (Standard)
5	6490	Vehicular Charger
6	7680	External Microphone (internal speaker)
7	9530	Speaker Mic (continuous Sw Bat)
8	3160	Deluxe Vehicular Charger*
9	OPEN**	No external options. Switch used for future expansions
10	OPEN	No external options. Switch used for future expansions
11	OPEN	No external options. Switch used for future expansions
12	OPEN	No external options. Switch used for future expansions

* This register is not installed in the test box.

** 2210 Ω is used for the MPD Voice Guard keyloader. Add that value if you have the need.

TQ0609A - Version

Revision "A" of the TQ0609 is incorporated to add the M-RK Personal radio to the list of radios that the test box can be used to test. The cable that connects to the radio's UDC has been removed and a DB15-M connector and 2 banana jacks have been added to the box.

The cable that was used to test the earlier radios now has a DB15-F connector that plugs into the DB15-M connector on the test box. This cable is included with the TQ0609-A. The testing of the radios is the same as with the TQ0609.

To test the M-RK radios, a test cable (19B801971P6) is connected to the DB15-M of the test box and to the UDC of the M-RK radio. The testing of the radio will be much the same as the earlier radios. There is no external point that the speaker audio is available on the M-RK. (Low level RX-AUD is still available from the UDC.) When the M-RK has its cover assembly removed, a test cable (K19/AS00000420) is plugged into the P3 connector on the M-RK controller and the other end of the cable connects to the DB15-M connector of the test box. All of the functions of the UDC are retained as well as the feature of being able to test the speaker audio of the M-RK. The speaker circuit is loaded with an internal 15 ohm resistor and isolated with an internal 1:1 transformer. The output of the speaker circuit is available at the M-RK SPEAKER banana jacks on the side of the TQ0609A test box.

CAUTION

M-RK SPEAKER output is only for test equipment and not an external speaker. Connecting a speaker could damage the test box's internal isolation transformer.

TESTING

1. With power off to the radio connect the TQ0609 to the UDC of the radio. Place the UDC switch to the 1 position. Place the TX-DATA switch into the 0 position. The TX-DATA switch must be in the 0 position for the radio to recognize that an external option is present. Apply power to the radio. The radio should go into the programming mode. About 7 volts can be measured at the BAT-SW terminal for the radios except for the TPX. This voltage is needed to power the programmer interface while programming, also to power the speaker circuits of the speaker microphone option.
2. Remove power from the radio. Place the UDC switch into the 2 position, and apply power to the radio. The radio now assumes that the speaker microphone is attached. The radio can be keyed by pressing the PTT switch momentarily to the left or locking it into the transmit mode by placing the switch to the right position. Transmit audio now is applied through the red mic hi input. This input is DC coupled and should have about 2.5 volts DC on the terminal. This voltage is used to provide bias for the external electret mic used with the radios. If your audio generator/oscillator can be damaged by this voltage, you may elect to isolate the circuit from the oscillator by placing about a 10 to 220 micro-Farad capacitor in series with the mic hi line. Transmitter tests may be performed on the radio as outlined in the T&T Handbook. For the trunking type radios, they will have to be placed into a conventional system or mode to test the radios.

Receive audio power amplifier circuits are not utilized in this test, but if a valid signal is received there will be about 7 volts at the BAT-SW lead and the recovered audio may be seen at the RX AUDIO lead. This is the audio after the volume control but before the audio power amplifier. The level of the audio is varied by the audio control and may go to around .5 V rms (noise) at the RX-AUD terminal. While the receiver audio circuits are squelched there is about a 1 ohm short to ground at the MUTE lead, but when a signal is received the MUTE leads resistance will go to open (above 1 meg-ohm).
3. Remove power from the radio. Place the UDC switch into the 3 position, and apply power to the radio. The radio now assumes that the earphone option is attached. Transmitter audio and keying is the normal internal microphone and the PTT bar on the side of the radio. The internal receive audio power amplifier is disabled and RX-AUD lead operates as step 2. But there is no 7 Vdc at the BAT-SW lead when the radio is unmuted.
4. Remove the power from the radio. Place the UDC switch into the 4 position, and apply power to the radio. The radio now assumes that the vehicular charger option is attached. The radio should perform the same as when the UDC switch was in position 2.
5. Remove power from the radio. Place the UDC switch into the 5 position, and apply power to the radio. The radio now assumes that the vehicular charger option is attached. The radio should perform the same as when the UDC switch was in position 2. There is no difference in the operation of the radio between position 4 and 5. The resistance value of position 4 is the standard vehicular charger resistance.

6. Remove power from the radio. Place the UDC switch into the 6 position, and apply power to the radio. The radio now assumes that the external microphone option is attached. The transmitter circuits work as if an external microphone was connected like in step 1, but now the audio circuits of the receiver are enabled. This is the most convenient position to test the audio and RF portions of the radio. With the K19/A4WX01543 Dummy Battery/Speaker Load connected to the radio, all of the standard test as mentioned in the T&T Handbook can be performed. Again, keep in mind that trunking radios will have to be put on a conventional system or mode before testing.
7. Remove power from the radio. Place the UDC switch into the 7 position, and apply power to the radio. The radio now assumes that the speaker microphone option is attached. This position works as position 2 but 7 Vdc at the BAT-SW lead is always present.
- 8.-12. The remainder of the switch positions were left open so that other resistors may be added for future expansions. Always keep one open so that you can switch back to normal without taking the box loose.

Future Expansion #1

A 2210 (1%) ohm resistor may be added to the next open position to simulate the Voice Guard keyloader on MPD Voice Guard or EDACS MPD Voice Guard radios.

Test Points

RX-AUD Audio out of the receiver after the volume control but before the audio power amplifier. It is not de-emphasized and is used to run external amplifiers such as the speaker/mic and vehicular charger.

This lead is about 5.25 Vdc in the receive mode and drops to less than .2 Vdc in the transmit mode. This lead will change even with no external option connected.

MUTE This lead should be labeled MUTE bar because it is low when the receiver is muted and high when the receiver is unmuted. It is an open collector type output, so an external pull-up resistor must be used or use an ohm-meter to measure an open (hi) or short (low). This lead will also change even with no external option connected.

EMER Emergency is the point that the external GE-STAR lanyard is connected. If GE-STAR lanyard option is enabled for the radio his terminal must be short over A- with a piece of wire. If not the radio will sense it is in an emergency and will key into your valuable test equipment and possibly damage your equipment.

DISC This is the discriminator output of the receiver. Unfiltered audio is always at this terminal. With no signal, there is about 825 milli-volts rms riding on about 2.5 Vdc at this terminal.

CTS Clear to Send is used during programming of the radio, and the levels at this terminal is also dependent on the type of radio connected.

RX-DATA This lead is used in programming the radio. Data enters the radio on this terminal.

TX-DATA This lead is used in programming the radio. Data leaves the radio on this terminal.

BAT-SW This lead is used to power external options, such as the programming interface box and the speaker/mic options. It provides about 7 volts from a switched transistor.

A- This is battery A- and all reference measurements are from this point. This is the same point as the black terminal of the microphone input.



Ericsson GE Mobile Communications Inc.
Mountain View Road • Lynchburg, Virginia 24502

TEST BOX
TQ0609
ISSUE 1

PARTS LIST - REV. A

SYMBOL	PART NUMBER	DESCRIPTION
		----- JACKS -----
	5490384P3	Tip jack, red.
	19B209152P2	Banana jack, red.
	19B209152P3	Banana jack, black.
		----- RESISTORS -----
	19A701250P256	3740 ohms ±1% 1/4 w.
	19A701250P263	4420 ohms ±1% 1/4 w.
	19A701250P271	5360 ohms ±1% 1/4 w.
	19A701250P279	6490 ohms ±1% 1/4 w.
	19A701250P286	7680 ohms ±1% 1/4 w.
	19A701250P295	9530 ohms ±1% 1/4 w.
		----- SWITCHES -----
		C & K 46F-744, rotary, 12 position. ALCO PKG 50B 1/8, rotary knob.
	19C850845P25	Toggle, ON-OFF-Momentary (TX PTT).
	19C850845P26	Toggle, ON-OFF (TX DATA).
		----- MISCELLANEOUS -----
	19A127319P6	Nuts for toggles. NEWARK SRR-10, strain relief.
		TEST CABLE ASSEMBLY K19/A4WX01541
		----- CAPACITORS -----
C1	K19/2CAJ023098	Ceramic, fixed: 1000 pf, DD104B102K50V02.
		----- CONNECTORS -----
P1	K19/2PCB003377	RF, Y-73B, A4WL07650.
		----- CABLES -----
CA1	K19/2WHC005794	RF, BNC-P-58/U, L-25, A4WX01572#1.
		----- WIRES -----
W1		Mini Cable, 14 leads, A4WX01641.

SYMBOL	PART NUMBER	DESCRIPTION
		--- JACKS ---
	5490384P3	TIP JACK, RED
	19B209152P2	BANANA JACK, RED
	19B209152P3	BANANA JACK, BLACK
		--- RESISTERS ---
	19A701250P234	2210 OHM, 1/4 W, 1%
	19A701250P249	3160 OHM, 1/4 W, 1%
	19A701250P256	3740 OHM, 1/4 W, 1%
	19A701250P263	4420 OHM, 1/4 W, 1%
	19A701250P271	5360 OHM, 1/4 W, 1%
	19A701250P279	6490 OHM, 1/4 W, 1%
	19A701250P286	7680 OHM, 1/4 W, 1%
	19A701250P295	9530 OHM, 1/4 W, 1%
		--- SWITCHES ---
		C&K 46F-744, Rotary, 12 Pos. ALCO PKG 50B 1/8, Rotary Knob
	19C850845P25	Toggle, On-Off-Momentary (PTT)
	19C850845P26	Toggle, On-Off (TX-DATA)
		--- MISCELLANEOUS ---
	19A127319P6	Nuts for toggles. NEWARK SRR-10, strain relief.
		TEST CABLE ASSEMBLY K19/A4WX01541
		--- CAPACITORS ---
C1	K19/2CAJ023098	Ceramic, fixed: 1000 pf, DD104B102K50V02
		--- CONNECTORS ---
P1	K19/2PCB003377	RF, Y-73B,
		--- CABLES ---
		RF, BNC-P-58/U, L-25
		--- WIRES ---
W1	K19/A4WX01641	Mini Cable 14 leads

* COMPONENTS, ADDED, DELETED OR CHANGED BY PRODUCTION CHANGES

HOOKSWITCH 19C320318G5

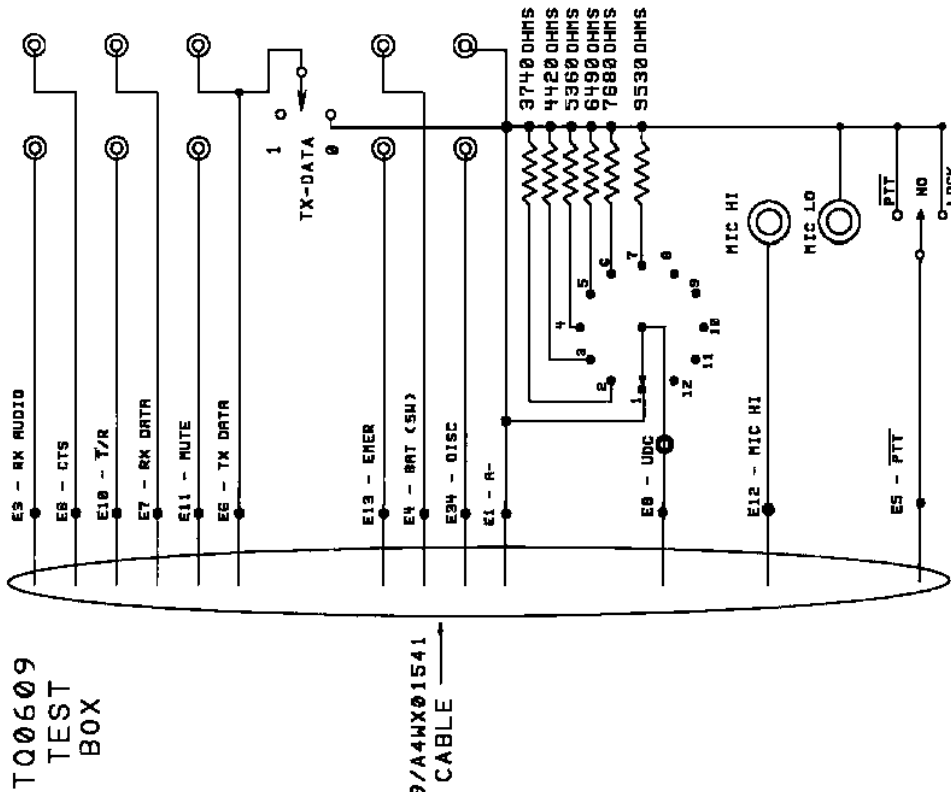

ALL RESISTERS ARE 1/4w, 1%.
 T00609 TEST BOX

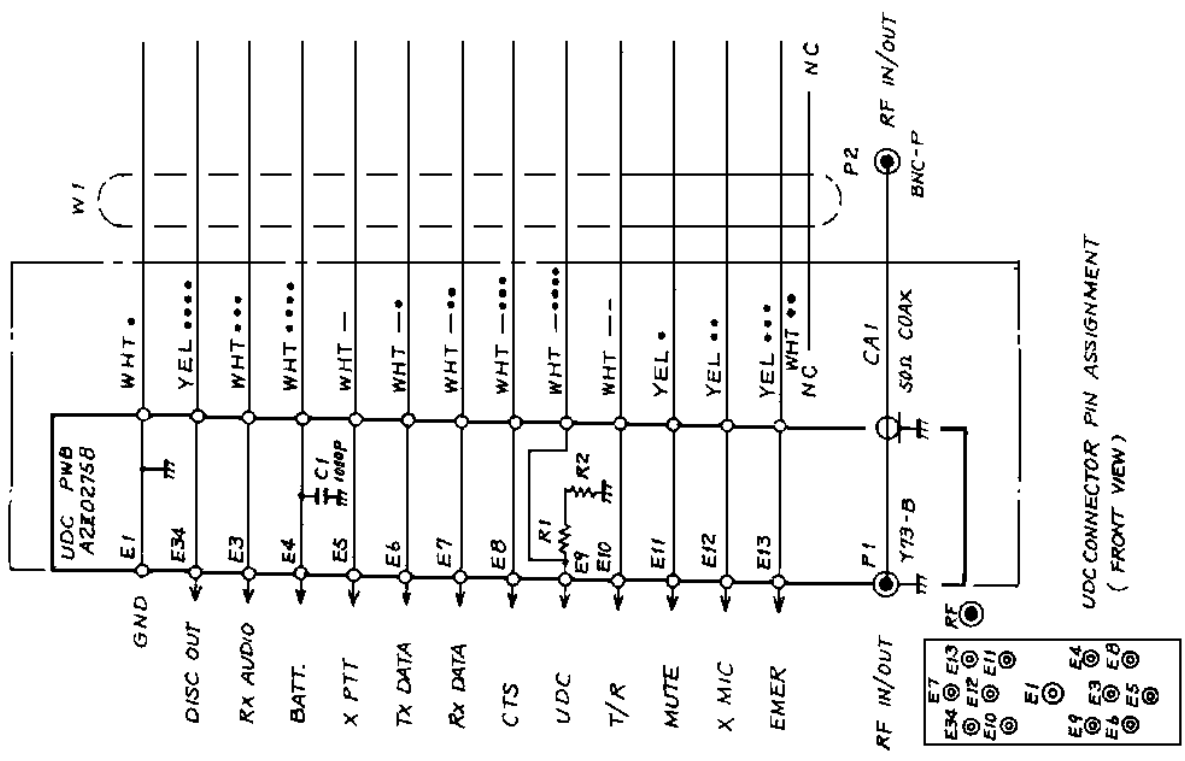

UDC CONNECTOR PIN ASSIGNMENT
 (FRONT VIEW)

UDC TEST CABLE

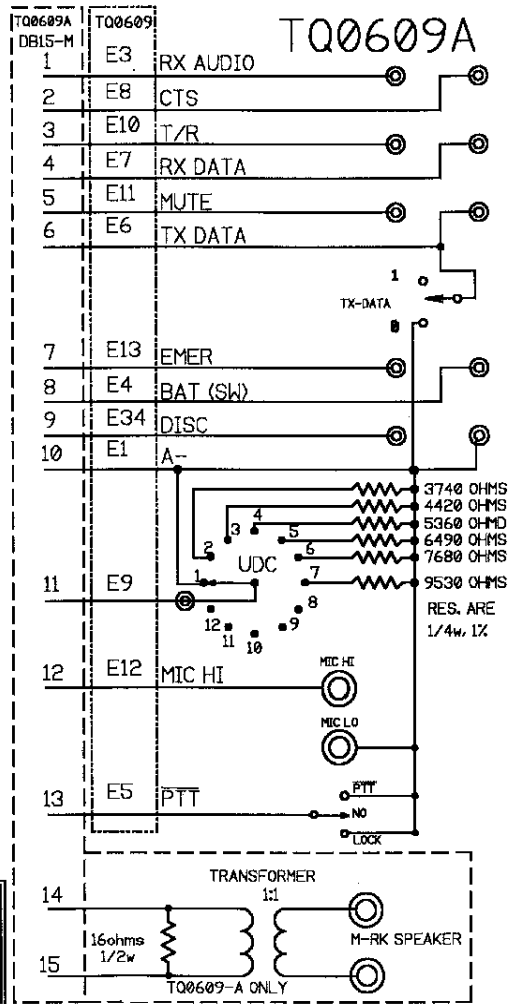
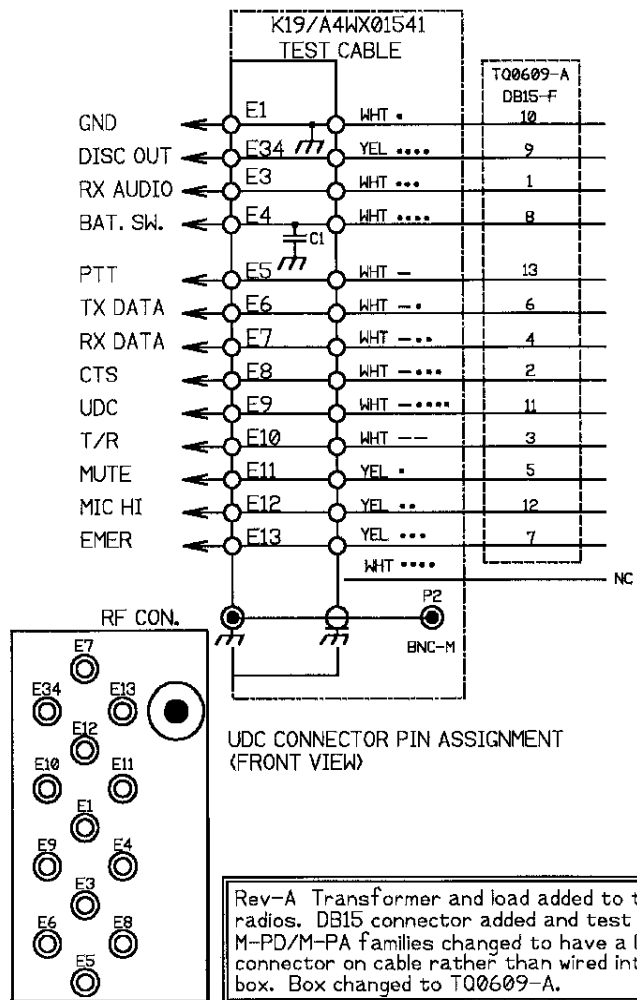

TOP VIEW

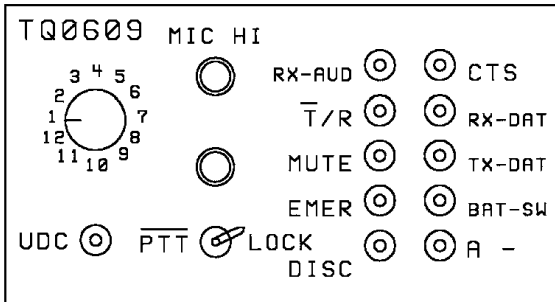

SIDE VIEW

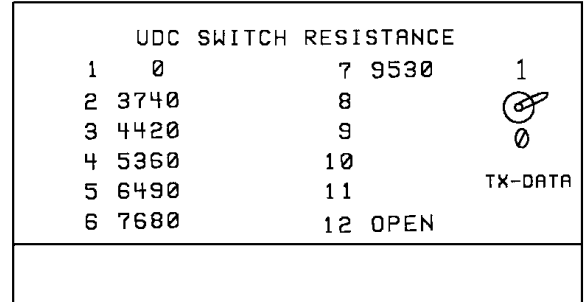

HOOKSWITCH 19C320318G5

LAYOUT DIAGRAM - REV. A

TOP VIEW

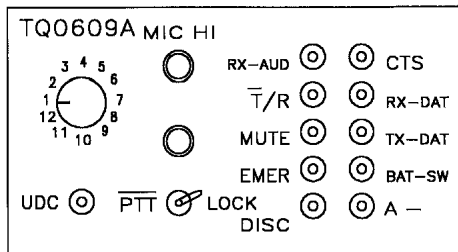

METERING JACKS ARE TIP JACKS
 MIC HI JACKS ARE 3/4" GR JACKS
 PTT SWITCH IS SPDT WITH CENTER OFF
 UDC SW. IS MIN. OF 10 POS.

SIDE VIEW

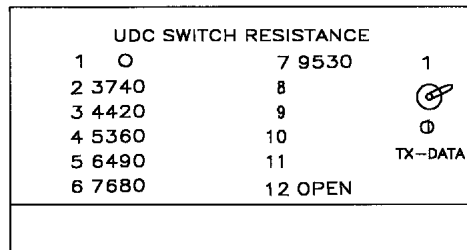

SIDE VIEW

