

MAINTENANCE MANUAL
UHF REAR COVER ASSEMBLY
19C337097G4 - G7, G11, G13, G17

TABLE OF CONTENTS

DESCRIPTION	Page
	Front Cover
CIRCUIT ANALYSIS	1
ANTENNA SWITCH AND LOW-PASS- FILTER	1
T/R SWITCH DIODES	1
TRANSMITTER	1
RECEIVER	1
SYNTHESIZER	2
PARTS LIST	3
PRODUCTION CHANGES	5
MECHANICAL PARTS	5
OUTLINE DIAGRAM	6
SCHEMATIC DIAGRAM	7 & Back Cover

DESCRIPTION

The Rear Cover Assembly consists of the UHF RF Board, a die-cast aluminum case and the associated hardware. The RF Board assembly includes soldered-in modules, integrated circuits and surface-mounted components.

This double-sided printed-wire board is surrounded by a die-cast aluminum casting and mounted in the rear cover case. This arrangement provides excellent RF shielding between the various circuits and the outside environment. A cover shield provides shielding between the RF Board and the digital circuits located in the front cover.

Table 1 - Applications

OPERATING RF BAND (MHZ)	FACTORY TUNED FOR (MHZ)	REAR COVER ASSEMBLY	RF BOARD	PRODUCT
378 - 413	378 - 413	19C337097G11	19D902282G10	P400
403 - 440	403 - 423	19C337097G4	19D902282G1	M-PA
440 - 470	450 - 470	19C337097G5	19D902282G6	M-PA, MTL
470 - 494	470 - 492	19C337097G6	19D902282G3	M-PA
492 - 514	492 - 512	19C337097G7	19D902282G8	M-PA
440 - 470	450 - 470	19C337097G13	19D902282G13	M-PA ETSI
485-505	485-505	19C337097G17	19D902282G17	M-PA

SCHEMATIC DIAGRAM

PART	G1 423-440-MHZ	G3 470-494 MHz	G6 440-470-MHZ	G8 492-514 MHz	G10 378-413 MHz	G13 440-470 MHz	G17 485-505 MHz
C1	5.6P	2.2P	3.3P	3.0P	5.6P	3.3P	3.0P
C2	8.2P	1.8P	6.8P	3.3P	8.2P	6.8P	3.3P
C3	4.7P	2.2P	0.3P	2.2P	—	0.3P	2.2P
C4	10P	2.7P	0.9P	4.7P	10P	0.9P	4.7P
C5	3.3P	2.2P	8.2P	1.8P	3.3P	8.2P	1.8P
C6	—	0.5P	—	0.5P	—	—	0.5P
C7	5.6P	2.2P	3.9P	3.0P	5.6P	3.9P	3.0P
C14	—	2.2P	—	1.8P	—	—	1.8P
C15	6.8P	8.2P	10P	8.2P	4.7P	3.9P	8.2P
C36	6.8P	5.6P	4.7P	5.1P	6.8P	4.7P	5.1P
C37	5.6P	3.3P	4.7P	3.3P	5.6P	4.7P	3.3P
C60	3.9P	3.9P	4.7P	3.3P	3.9P	2.2P	3.3P
C68	—	—	0.9P	—	—	0.9P	—
C69	8.2P	6.8P	3.3P	6.8P	4.7P	5.6P	6.8P
C72	—	2.2P	—	1.8P	—	—	1.8P
C76	56P	56P	4.7P	47P	68P	33P	47P
C77	43P	33P	33P	33P	27P	15P	33P
C78	33P	33P	33P	33P	39P	33P	33P
C79	2.2P	4.7P	3.3P	4.7P	2.2P	12P	4.7P
C80	8.2P	6.8P	10P	6.8P	8.2P	15P	6.8P
C81	1.8P	2.7P	6.8P	2.2P	1.8P	10P	2.2P
L2	2.5T	1.5T	2.5T	1.5T	2.5T	2.5T	1.5T
L3	2.5T	1.5T	2.5T	1.5T	2.5T	2.5T	1.5T
L4	2.5T	1.5T	2.5T	1.5T	2.5T	2.5T	1.5T
L14	15NH	12NH	10NH	12NH	18NH	22NH	12NH
L15	15NH	12NH	12NH	12NH	18NH	22NH	12NH
L18	22NH	22NH	22NH	22NH	22NH	15NH	22NH
L19	22NH	22NH	18NH	22NH	22NH	15NH	22NH
R4	470 OHMS	470 OHMS	470 OHMS	—	470 OHMS	—	—
R5/C84	12 OHMS	12 OHMS	12 OHMS	470P	12 OHMS	33P	470P
R6	470 OHMS	470 OHMS	470 OHMS	—	470 OHMS	—	—
R11	39K	100K	39K	100K	100K	39K	27K
R48	4.7K OHMS	4.7K OHMS	4.7K OHMS	—	4.7K OHMS	—	—
R49	4.7K OHMS	4.7K OHMS	4.7K OHMS	—	4.7K OHMS	—	—
C85	—	—	—	—	—	4700P	—
C86	—	—	—	—	—	100P	—
C87	—	—	—	—	—	100P	—
R79	—	—	—	—	—	—	100K
R34	1K	1K	1K	1K	1K	1K	2.7K
R80	—	—	—	—	—	—	51
C102	—	—	—	—	—	—	22P

RF BOARD
19D902282G1, G3, G6, G8, G10, G13 & G17

(19D902269, Sh. 2, Rev. 18)

Ericsson Inc.
 Private Radio Systems
 Mountain View Road
 Lynchburg, Virginia 24502
 1-800-528-7711 (Outside USA, 804-528-7711)



CIRCUIT ANALYSIS

The RF Board is electrically connected to the Control Board by two single-in-line connectors. Power supplies include 7.5 Vdc (battery power) and a regulated 5.4 Vdc supply from the Control Board located in the Front Cover Assembly.

Logic inputs from the Control Board include serial synthesizer loading data, power-save, and a switched 5.4 Vdc source to enable the transmitter and disable the receiver circuits. Other signals from the Control Board include modulating audio and the transmitter power level set line when a transmission is enabled.

The RF Board provides the FM demodulated audio and synthesizer lock status to the Control Board. During transmitter operation RF power appears at the top antenna jack or the UDC jack if an appropriate adapter is inserted.

ANTENNA SWITCH AND LOW-PASS FILTER

The antenna switch, located at the top of the RF Board, selects the top mounted antenna or a UDC antenna option. A spring-loaded contact in the switch normally connects the low-pass filter to the top mounted antenna. When a UDC accessory (or an RF test plug) that utilizes the UDC antenna jack is installed, RF is routed to/from the UDC antenna jack instead of the top jack. Connecting an accessory to the UDC jack pushes the small gold plated center pin inside the unit, switching the filter from the top antenna jack to the UDC antenna jack.

Low-pass filter consists of capacitors C1 - C7, C14, C72 and inductors L1 - L4. L1 provides a dc path to ground for the antenna. This LC network rejects unwanted harmonics in the received and transmitted signal. The network has a rejection of more than 65 dB in the stopband. The filter has input and output impedances of 50 ohms.

T/R SWITCH DIODES

Antenna T/R switch diodes connect the transmitter's output or the receiver's input to the low-pass filter (and antenna) during transmit and receive modes respectively. Two pin diodes are biased by the TX 5.4V line to route the RF properly.

When the radio is transmitting, the diodes are forward-biased by a high level (5.4 Vdc) on the TX 5.4V line. RF power from the transmitter (Power Controller module pin 14) passes through D1 to the low-pass filter network and the antenna. Forward-biased D2 prevents any transmit RF from entering the receiver by providing a low-impedance path to ground at the

receivers input. Network C36, C37 and L9 serves to attenuate transmitter power before it reaches D2. The two diodes are forward biased by the following dc path: TX 5.4V line, R53, R1, L5, D1, L9, D2 and ground.

In receive mode, with TX 5.4V low (both diodes off), RF from the antenna and is routed to the receiver's front-end.

TRANSMITTER

The UHF transmitter circuit includes the Power Amplifier IC, the Power Controller module and support circuitry for these components. The Power Controller module regulates the radio's RF power by sampling the power being delivered to the antenna from the PA IC, and controlling the PA accordingly.

In order to transmit, the Control Board in the front cover must supply the following signals to the RF Board:

- the synthesizer must be loaded and locked with the proper TX frequency data via STROBE, DATA and ENABLE
- J101 pin 5 (TX 5.4V) must be high (5.4 Vdc)
- J101 pin 1 (PWR SET) must be set to a level corresponding to the programmed power level (high or low)
- modulating audio must be present on J102 pin 1

Power Amplifier IC U4

Power Amplifier IC U4 is a four-stage device mounted to the "eggerate" casting. This casting serves as a heat sink. U4 provides approximately 36 dB gain for the transmitter. RF drive is applied to pin 1 from the VCO. The IC's output is on pin 7.

Battery power for the PA is sourced from the 7.5V BATT line via L6, L7, L8, L16, L17, Q1 and Q4. The associated LC networks provide decoupling.

Transistor Q4 turns on when the radio is transmitting to supply 7.5 Vdc ($\pm 20\%$) to U4 pins 2 and 4. Transistor Q1 supplies dc power to U4 pin 3. Q1 operates in a linear mode to regulate RF power as driven by the Power Controller.

Power Controller Module A1

Power Controller A1 regulates the RF output power as set by the programmed power level. This module maintains constant output power despite battery voltage variations or tem-

perature related gain variations of the PA. Operating power for this module is supplied from the TX 5.4V line when a transmission is enabled.

RF enters A1 at pin 1 and exits at pin 14 at a loss of 0.1 dB. A microstrip directional-coupler inside the module samples the RF power. This signal is then rectified and compared to the PWR SET line from the Control Board; an error signal is produced which drives transistor Q1 to control the PA IC's gain. This feedback method of power control maintains constant RF output power as set by the digital-to-analog converter on the Control Board.

The PWR SET signal from J101 pin 1 is decoupled by R31, C83 and C65 and applied to the Power Controller at pin 12. This dc reference level varies from approximately 1 Vdc (low power) to 4 Vdc (high power). In receive mode, PWR SET is 0 Vdc.

NOTE

Outline and schematic diagrams for the modules are shown in the Service Section. The modules are not serviceable; schematics and outlines are given as a troubleshooting aid only.

Harmonic Filter

Transmit VCO drive from A4 is connected to the PA by a harmonic filter network that has a rejection of more than 35 dB in the stopband. Capacitor C15 couples the drive to the PA module.

RECEIVER

The receiver utilizes the dual-conversion superheterodyne technique to recover the desired signal. Low-side injection from the synthesizer circuit produces a high IF frequency of 45 MHz at the output of the first mixer. The second mixer uses high-side injection from a crystal oscillator to produce the desired second IF of 455 kHz. LC and crystal filters are incorporated throughout the receiver circuit. This arrangement produces excellent sensitivity, selectivity and image rejection.

Front-End

Capacitor C35 couples RF from the low-pass input filter and T/R switch circuit to Bandpass Filter FL4. FL4 is a

passive LC network that provides front-end image frequency protection. The filter has an insertion loss of less than 4 dB in the passband. RF is then passed to RF Amp A6.

Module A6 is a common-emitter configured RF amplifier module that serves as a preamplifier before the mixer circuit. It provides approximately 8 dB of gain and has terminal impedances of 50 ohms. The module consumes less than 4 milliamperes of current from the decoupled supply on pin 5. A6's output is applied to FL1 pin 1.

Bandpass Filter FL1 is a three-pole LC device identical to FL4 (within each band-split). Both filters are factory tuned to cover the operating frequency range of the radio. See Table 1 for details.

RF from FL1 enters double balanced First Mixer U5 at pin 1. Synthesized VCO injection (at 7 dBm) from A4 pin 9 is applied to U5 pin 8. The 45 MHz converted signal appears on pins 3 and 4 at a maximum conversion loss of 7 dB. Impedances at all ports is 50 ohms. C45 and L13, series tuned to 45 MHz, couple the converted signal to the High IF Amp.

High IF Amp, Crystal Filter and Buffer

High IF Amplifier A2 is a single transistor, common-base, non-tunable transistor amplifier module. Center frequency is 45 MHz and the IF signal is introduced on pin 2. This module has input and output impedances of 50 ohms. The amplified signal is applied to FL2 by pin 5.

High IF Filter FL2 is a monolithic crystal filter with a center frequency of 45 MHz. It has a 3 dB bandwidth of ± 7.5 kHz minimum and terminal impedances of 50 ohms. Loss in the passband is 4 dB maximum. The filter's output is coupled to IF Buffer Amp Q3 by C10. The LC network (L12//C57//C10) at pin 2 is tuned to the IF frequency.

High IF Buffer Amp Q3 is a common-base non-tunable amplifier stage. This stage matches the low impedance output of FL2 to the high impedance input of U6.

Back-End

The back-end circuits perform second conversion and demodulation of the FM signal. Capacitor C56 couples the 45 MHz IF signal from Q3 to pin 16 of U6.

Integrated circuit U6 is a 16-pin DIP IC that contains an oscillator, mixer, limiter, demodulator and audio amplifier. Using external crystal Y1, a 45.455 MHz signal is generated in the IC for the second mixer high-side injection. Alignment for this 2nd LO is provided by coil T1.

The mixer's output from U6 pin 3 passes through 455 kHz filter FL3. This filter has an input and output impedances of approximately 1500 ohms with a stopband attenuation of 35 dB minimum. It has an insertion loss of 4 dB and a center frequency of 455 kHz ±1.5 kHz. The 455 kHz output signal from FL3 is returned to U6's limiter input pin 5.

The limiter stage in U6 is internally connected to the demodulator stage. Alignment for the internal quadrature detector is provided by coil T2. The recovered audio is available on U6 pin 9. Audio is applied to J101 pin 4 for passage to the audio circuits in the Front Cover Assembly. Deemphasis is performed by C44 and R28.

SYNTHESIZER

The microprocessor-controlled phased-locked loop (PLL) synthesizer produces the transmitter's drive and the receiver's first mixer injection. Primary components include a stable reference oscillator, a voltage-controlled oscillator (VCO), a dual-modulus prescaler chip and a serially-loaded synthesizer chip. A PLL filter module integrates the analog error signal from the synthesizer chip before it is passed to the VCO.

Reference Oscillator U3

Reference Oscillator U3 produces a 13.2 MHz crystal reference frequency for the synthesizer chip. Capacitors C16 and C54 couple this reference signal to the synthesizer chip. The synthesizer chip phase compares this reference signal to the divided VCO signal; it produces an error signal which tunes the VCO. During a transmission, audio signals from TX AUDIO are ac coupled to U3 via C30. These audio signals frequency modulate the 13.2 MHz signal. Modulation Balance potentiometer R18 is adjusted for best low-frequency response with a 20 Hz, 1 Vp-p square-wave TX AUDIO input. TX AUDIO is also coupled to the VCO to provide modulation.

Regulated 5.4 Vdc is applied to pin 3 by R12. Capacitor C27 provides the necessary supply decoupling for the oscillator.

U3 has a small opening on the top which provides access to an internal frequency adjustment. This oscillator is factory aligned and it is highly stable. It should not normally need alignment in the field.

Voltage-Controlled Oscillator Module A4

VCO module A4 is the largest and most complex module on the RF Board. This module has separate internal TX and RX oscillators which generate the transmitter drive and receiver first LO injection signals. When TX 5.4V is high, the TX oscillator is enabled and the RX oscillator is disabled. Output frequency for both oscillators is controlled by the tuning voltage on pin 5. The VCO module is factory tuned to cover the operating frequency range of the radio.

A regulated power supply of 5.4 Vdc is delivered to A4 pin 7. This supply is developed from the regulator circuit in A5A. R32 and C52 decouple this supply.

The VCO also requires a negative power supply for operation. This supply is generated from the OSC OUT of U1. On the positive cycle of OSC OUT, C47 charges through R34 and D3 (pins 1 - 3). When OSC OUT returns low, C47 charges C48 via R34 and D3 (pins 2 and 3). R35 and C49 provide additional filtering. Approximately -3.7 Vdc is present on A4 pin 6.

In transmit mode the VCO is phased-locked to the TX channel's frequency. RF drive from A4 pin 1 is approximately 8 dBm. Table 2 lists tuning voltage data.

TX AUDIO frequency modulates the VCO. VCO Modulation potentiometer R19 sets the modulation level into the VCO from the TX AUDIO line. The pot is aligned so a 1 kHz, 600 mV rms TX AUDIO input will produce a deviation of 5.0 kHz.

In receive mode, the VCO is phased-locked 45 MHz below the RX channel's frequency. This LO signal is applied to the mixer and prescaler IC. Table 2 lists tuning voltage data.

Prescaler Stage

The VCO signal is buffered by common-emitter configured Q2 and applied to prescaler chip U2 via C20. Q2 prevents loading of the VCO by the prescaler chip. This dual-modulus prescaler divides the VCO signal by 128 or 129 according to the logic signal on the modulus control input (MC, pin 1). This modulus is controlled by U1; the chip divides-by 128 when the MC is high.

Table 2 - VCO Tuning Voltage VS. VCO Output Frequency

TUNING VOLTAGE (AT A4 PIN 5)		2.5 VDC
TOLERANCE		±2.0 MHz
378 - 413 MHz	TX RX	396.0 MHz 351.0 MHz
403 - 440 MHz	TX RX	413.0 MHz 368.0 MHz
440 - 470 MHz	TX RX	460.0 MHz 415.5 MHz
470 - 494 MHz	TX RX	482.0 MHz 437.0 MHz
492 - 514 MHz	TX RX	503.0 MHz 458.0 MHz
485 - 505 MHz	TX RX	496.0 MHz 450.5 MHz

Synthesizer IC U1

Integrated circuit U1 contains a reference frequency divider, variable frequency dividers and phase detectors for the synthesizer circuitry. This IC has an analog and a digital phase detector. The analog detector is incorporated in the main PLL and the digital detector output indicates lock status. Reference and variable frequency dividers are serially loaded by the clocked data line from the microprocessor. This IC controls the dividing factor of the prescaler by its modulus control (MC, pin 8) output.

Serial data from the microprocessor is shifted into U1 by the DATA line, J102 pin 10. Clocking is provided on the STROBE line, J102 pin 11, and the data is latched with the ENABLE pulse on J102 pin 9. When U1 pin 13 (LE) is high, data is transferred from the internal shift registers to the dividers; low inhibits the internal transfers. The tuning error signal from the analog phase detector appears on ALOG OUT, U1 pin 17. This tuning error signal is routed to PLL Filter A5B for additional filtering before it is applied to the VCO.

The digital phase detector's output on pin 9 is sent to the Control Board via J102 pin 8, LOCK DETect. The microprocessor checks this output to prevent transmission when the VCO is not locked. During an unlocked condition, LOCK DET is low or pulsing.

Voltage Regulator / Loop Filter Module A5

Module A5 has two functions. It provides switched supplies to the RF Board and it contains circuitry which provides additional filtering for the VCO tuning signal. Regulated 5.4 Vdc from J102 pin 6 is applied to A5 pin 7 and 7.5 Vdc ±20% (battery power) is applied to pin 11.

A5A supplies regulated 5.4 Vdc to the synthesizer's circuitry and the back-end circuits via pins 9 and 10 respectively. In addition, 7.5 Vdc is supplied to the RF and IF amplifier modules via A5A pin 12.

A5B provides further filtering of the tuning error signal from the synthesizer chip before it is applied to the VCO. Inside the module, an active filter circuit integrates the tuning error signal from the synthesizer chip. Pin 4 is driven by the ENABLE line. When high, the response time of the filter circuit is decreased. This allows the synthesizer to lock quickly when new data is loaded into U1. Capacitor C25 is the primary integrating capacitor and C26 on A5B's output provides further integration of the tuning error signal before it is applied to the VCO.

PARTS LIST

LBI-38383H

REAR COVER ASSEMBLY
 19C337097G13 440-470 MHz
 19C337097G11 378-413 MHz
 19C337097G4 403-440 MHz
 19C337097G5 440-470 MHz
 19C337097G6 470-494 MHz
 19C337097G7 492-514 MHz
 19C337097G17 485-505 MHz
 ISSUE 9

SYMBOL	PART NO.	DESCRIPTION
		RF BOARD
		19D902282G10 378-413 MHz
		19D902282G1 403-440 MHz
		19D902282G6 440-470 MHz
		19D902282G3 470-494 MHz
		19D902282G8 492-514 MHz
		19D902282G13 440-470 MHz
		19D902282G17 485-505 MHz
		----- MODULES -----
A1	19C337063G3	Power Controller Module.
A2	19C336876G1	IF Amplifier Module.
A4	19D438605G3	VCO Module. (Used in G1).
A4	19D438605G5	VCO Module. (Used in G3).
A4	19D438605G1	VCO Module. (Used in G6).
A4	19D438605G7	VCO Module. (Used in G8).
A4	19D438605G9	VCO Module. (Used in G10).
A4	19D438605G11	VCO Module. (Used in G13).
A4	19D438605G13	VCO Module. (Used in G17).
A5	19C852056G3	PLL Lowpass Filter/Regulator Module.
A5	19C852056G5	PLL Lowpass Filter/Regulator Module. (Used in G13 & G17).
A6	19B235081G3	UHF RF Amplifier Module. (Used in G1 & G10).
A6	19B235081G5	UHF RF Amplifier Module. (Used in G3, G8 & G17).
A6	19B235081G1	UHF RF Amplifier Module. (Used in G6, G13 & G17).
		----- CAPACITORS -----
C1	19A702236P19	Ceramic: 5.6 pF ±5 pF, 50 VDCW, temp coef 0 ±30 PPM/°C. (Used in G1).
C1	19A702236P10	Ceramic: 2.2 pF ±2.5 pF, 50 VDCW, temp coef 0 ±30 PPM/°C. (Used in G3).
C1	19A702236P13	Ceramic: 3.3 pF ±5%, 50 VDCW, temp coef 0 ±30 PPM/°C. (Used in G6 & G13).
C1	19A702236P12	Ceramic: 3.0 pF ±0.25 pF, 50 VDCW; temp coef 0 ±30 PPM/°C. (Used in G8, G17).
C1	19A702236P19	Ceramic: 5.6 pF ±5 pF, 50 VDCW, temp coef 0 ±30 PPM/°C. (Used in G10).
C2	19A702236P23	Ceramic: 8.2 pF ±25 pF, 50 VDCW, temp coef 0 ±30 PPM/°C. (Used in G1).
C2	19A702236P9	Ceramic: 1.8 pF ±0.25 pF, 50 VDCW, temp coef 0 ±30 PPM/°C. (Used in G3).
C2	19A702236P21	Ceramic: 6.8 pF ±0.5 pF, 50 VDCW, temp coef 0 ±60 PPM/°C. (Used in G6, G13).
C2	19A702236P13	Ceramic: 3.3 pF ±5%, 50 VDCW, temp coef 0 ±30 PPM/°C. (Used in G8 & G17).
C2	19A702236P23	Ceramic: 8.2 pF ±25 pF, 50 VDCW, temp coef 0 ±30 PPM/°C. (Used in G10).
C3	19A702236P10	Ceramic: 2.2 pF ±2.5 pF, 50 VDCW, temp coef 0 ±30 PPM/°C. (Used in G3, G8 & G17).
C3	19A702236P1	Ceramic: 0.5 pF ±1 pF, 50 VDCW, temp coef 0 ±30 PPM/°C. (Used in G6 & G13).
C4	19A702236P25	Ceramic: 10 pF ±5 pF, 50 VDCW, temp coef 0 ±30 PPM/°C. (Used in G1 & G10).

SYMBOL	PART NO.	DESCRIPTION
C4	19A702236P11	Ceramic: 2.7 pF ±0.25 pF, 50 VDCW, temp coef 0 ±30 PPM/°C. (Used in G3).
C4	19A702236P5	Ceramic: 0.9 pF ±1 pF, 50 VDCW, temp coef 0 ±30 PPM/°C. (Used in G6, G13).
C4	19A702236P17	Ceramic: 4.7 pF ±5%, 50 VDCW, temp coef 0 ±30 PPM/°C. (Used in G8 & G17).
C5	19A702236P13	Ceramic: 3.3 pF ±5%, 50 VDCW, temp coef 0 ±30 PPM/°C. (Used in G1).
C5	19A702236P10	Ceramic: 2.2 pF ±2.5 pF, 50 VDCW, temp coef 0 ±30 PPM/°C. (Used in G3).
C5	19A702236P23	Ceramic: 8.2 pF ±25 pF, 50 VDCW, temp coef 0 ±30 PPM/°C. (Used in G6, G13).
C5	19A702236P9	Ceramic: 1.8 pF ±0.25 pF, 50 VDCW, temp coef 0 ±30 PPM/°C. (Used in G8, G17).
C5	19A702236P13	Ceramic: 3.3 pF ±5%, 50 VDCW, temp coef 0 ±30 PPM/°C. (Used in G10).
C6	19A702236P1	Ceramic: 0.5 pF ±1 pF, 50 VDCW, temp coef 0 ±30 PPM/°C. (Used in G3, G8 & G17).
C7	19A702236P19	Ceramic: 5.6 pF ±5 pF, 50 VDCW, temp coef 0 ±30 PPM/°C. (Used in G1).
C7	19A702236P10	Ceramic: 2.2 pF ±2.5 pF, 50 VDCW, temp coef 0 ±30 PPM/°C. (Used in G3).
C7	19A702236P15	Ceramic: 3.9 pF ±25 pF, 50 VDCW, temp coef 0 ±30 PPM/°C. (Used in G6, G13).
C7	19A702236P12	Ceramic: 3.0 pF ±0.25 pF, 50 VDCW; temp coef 0 ±30 PPM/°C. (Used in G8, G17).
C7	19A702236P19	Ceramic: 5.6 pF ±5 pF, 50 VDCW, temp coef 0 ±30 PPM/°C. (Used in G10).
C8 and C9	19A702061P77	Ceramic: 470 pF ±5%, 50 VDCW, temp coef 0 ±30 PPM/°C.
C10	19A702236P52	Ceramic: 120 pF, ±5%, 50 VDCW.
C11	19A705205P13	Tantalum: 4.7 μF, 10 VDCW; sim to Sprague 293D.
C12 and C13	19A702052P14	Ceramic: 0.01 μF ±10%, 50 VDCW.
C14	19A702236P10	Ceramic: 2.2 pF ±2.5 pF, 50 VDCW, temp coef 0 ±30 PPM/°C. (Used in G3).
C14	19A702236P9	Ceramic: 1.8 pF ±0.25 pF, 50 VDCW, temp coef 0 ±30 PPM/°C. (Used in G8).
C15	19A702236P21	Ceramic: 6.8 pF ±0.5 pF, 50 VDCW, temp coef 0 ±60 PPM/°C. (Used in G1).
C15	19A702236P23	Ceramic: 8.2 pF ±25 pF, 50 VDCW, temp coef 0 ±30 PPM/°C. (Used in G3, G8 & G17).
C15	19A702236P25	Ceramic: 10 pF ±5 pF, 50 VDCW, temp coef 0 ±30 PPM/°C. (Used in G6).
C15	19A702236P17	Ceramic: 4.7 pF ±5%, 50 VDCW, temp coef 0 ±30 PPM/°C. (Used in G10).
C15	19A702236P15	Ceramic: 3.9 pF ±0.25 pF, 50 VDCW, temp coef 0 ±30 PPM/°C. (Used in G13).
C16	19A702052P14	Ceramic: 0.01 μF ±10%, 50 VDCW.
C17 and C18	19A705205P2	Tantalum: 1 μF, 16 VDCW; sim to Sprague 293D.
C19	19A702052P14	Ceramic: 0.01 μF ±10%, 50 VDCW.
C20 and C21	19A702061P77	Ceramic: 470 pF ±5%, 50 VDCW, temp coef 0 ±30 PPM/°C.
C22	19A702052P14	Ceramic: 0.01 μF ±10%, 50 VDCW.
C23	19A702061P69	Ceramic: 220 pF ±5%, 50 VDCW, temp coef 0 ±30 PPM/°C.
C24	19A702052P8	Ceramic: 3300 pF ±10%, 50 VDCW.
C25	19A703902P4	Metal: 0.56 μF ±10%, 50 VDCW.

SYMBOL	PART NO.	DESCRIPTION
C26	19A703902P3	Metal: 0.047 μF ±10%, 50 VDCW.
C27 and C28	19A702052P14	Ceramic: 0.01 μF ±10%, 50 VDCW.
C29	19A702061P77	Ceramic: 470 pF ±5%, 50 VDCW, temp coef 0 ±30 PPM/°C.
C30	19A705205P6	Tantalum: 10 μF, 16 VDCW; sim to Sprague 293D.
C31 thru C33	19A702061P77	Ceramic: 470 pF ±5%, 50 VDCW, temp coef 0 ±30 PPM/°C.
C34	19A702236P42	Ceramic: 47 pF ±5%, 50 VDCW, temp coef 0 ±30 PPM/°C.
C35	19A702061P61	Ceramic: 100 pF ±5%, 50 VDCW, temp coef 0 ±30 PPM/°C.
C36	19A702236P21	Ceramic: 6.8 pF ±0.5 pF, 50 VDCW, temp coef 0 ±60 PPM/°C. (Used in G1).
C36	19A702236P19	Ceramic: 5.6 pF ±5 pF, 50 VDCW, temp coef 0 ±30 PPM/°C. (Used in G3).
C36	19A702236P17	Ceramic: 4.7 pF ±5%, 50 VDCW, temp coef 0 ±30 PPM/°C. (Used in G6 & G13).
C36	19A702236P18	Ceramic: 5.1 pF ±0.5 pF, 50 VDCW, temp coef 0 ±60 PPM/°C. (Used in G8 & G17).
C36	19A702236P21	Ceramic: 6.8 pF ±0.5 pF, 50 VDCW, temp coef 0 ±60 PPM/°C. (Used in G10).
C37	19A702236P19	Ceramic: 5.6 pF ±5 pF, 50 VDCW, temp coef 0 ±30 PPM/°C. (Used in G1 and G10).
C37	19A702236P13	Ceramic: 3.3 pF ±5%, 50 VDCW, temp coef 0 ±30 PPM/°C. (Used in G3, G8, G17).
C37	19A702236P17	Ceramic: 4.7 pF ±5%, 50 VDCW, temp coef 0 ±30 PPM/°C. (Used in G6 & G13).
C38	19A700227P20	Ceramic: 5.6 pF ±5%, 100 VDCW.
C39 and C40	19A702061P21	Ceramic: 15 pF ±5%, 50 VDCW, temp coef 0 ±30 PPM/°C.
C41 thru C43	19A702052P34	Ceramic: 0.1 μF ±10%, 25 VDCW.
C44	19A702052P5	Ceramic: 1000 pF ±10%, 50 VDCW.
C45	19A702061P33	Ceramic: 27 pF ±5%, 50 VDCW, temp coef 0 ±30 PPM/°C.
C46 thru C48	19A702052P14	Ceramic: 0.01 μF ±10%, 50 VDCW.
C49	19A705205P2	Tantalum: 1 μF, 16 VDCW; sim to Sprague 293D.
C50	19A705205P2	Tantalum: 1 μF, 16 VDCW; sim to Sprague 293D (Used in G1, G3, G6, G8, G10, G17).
C50	344A3431P1	Ceramic: 1 μF, 16 VDCW. (Used in G13).
C51	19A702061P77	Ceramic: 470 pF ±5%, 50 VDCW, temp coef 0 ±30 PPM/°C.
C52	19A705205P2	Tantalum: 1 μF, 16 VDCW; sim to Sprague 293D.
C53 thru C56	19A702052P14	Ceramic: 0.01 μF ±10%, 50 VDCW.
C57	19A702236P25	Ceramic: 10 pF ±5 pF, 50 VDCW, temp coef 0 ±30 PPM/°C.
C58	19A702236P54	Ceramic: 150 pF ±5%, 500 VDCW, temp coef 0 ±30 PPM/°C.
C60	19A702236P15	Ceramic: 3.9 pF ±25 pF, 50 VDCW, temp coef 0 ±30 PPM/°C. (Used in G1, G3 and G10).
C60	19A702236P17	Ceramic: 4.7 pF ±5%, 50 VDCW, temp coef 0 ±30 PPM/°C. (Used in G6).
C60	19A702236P13	Ceramic: 3.3 pF ±5%, 50 VDCW, temp coef 0 ±30 PPM/°C. (Used in G8 & G17).

SYMBOL	PART NO.	DESCRIPTION
C60	19A702236P10	Ceramic: 2.2 pF ±2.5pF, 50 VDCW, temp coef 0±30PPM/°C. (Used in G13).
C61 and C62	19A702236P54	Ceramic: 150 pF ±5%, 500 VDCW, temp coef 0 ±30 PPM/°C.
C63 and C64	344A3431P1	Ceramic: 1 μF, 16 VDCW.
C65	19A702052P5	Ceramic: 1000 pF ±10%, 50 VDCW.
C68	19A702236P5	Ceramic: 0.9 pF ±1 pF, 50 VDCW, temp coef 0 ±30 PPM/°C. (Used in G6).
C69	19A702236P19	Ceramic: 5.6 pF ±5 pF, 50 VDCW, temp coef 0 ±30 PPM/°C. (Used in G1 & G13).
C69	19A702236P21	Ceramic: 6.8 pF ±0.5 pF, 50 VDCW, temp coef 0 ±60 PPM/°C. (Used in G3, G8 & G17).
C69	19A702236P13	Ceramic: 3.3 pF ±5%, 50 VDCW, temp coef 0 ±30 PPM/°C. (Used in G6).
C69	19A702236P17	Ceramic: 4.7 pF ±5%, 50 VDCW, temp coef 0 ±30 PPM/°C. (Used in G10).
C70	19A705205P13	Tantalum: 4.7 μF, 10 VDCW; sim to Sprague 293D.
C71	19A702052P14	Ceramic: 0.01 μF ±10%, 50 VDCW.
C72	19A702236P10	Ceramic: 2.2 pF ±2.5 pF, 50 VDCW, temp coef 0 ±30 PPM/°C. (Used in G3).
C72	19A702236P9	Ceramic: 1.8 pF ±0.25 pF, 50 VDCW, temp coef 0 ±30 PPM/°C. (Used in G8).
C73 and C75	344A3431P1	Ceramic: 1 μF, 16 VDCW.
C76	19A702236P42	Ceramic: 47 pF ±5%, 50 VDCW, temp coef 0 ±30 PPM/°C. (Used in G1, G6, G8 & G17).
C76	19A702236P44	Ceramic: 56 pF ±5%, 50 VDCW, temp coef 0 ±30 PPM/°C. (Used in G3).
C76	19A702236P46	Ceramic: 68 pF ±5%, 50 VDCW, temp coef 0 ±30 PPM/°C. (Used in G10).
C76	19A702236P38	Ceramic: 33pF ±5%, 50 VDCW, temp coef 0±30 PPM/°C. (Used in G13).
C77	19A70236P30	Ceramic: 15pF, ±5%, 50 VDCW, temp coef 0±30 PPM/°C. (Used in G13).
C77	19A702236P41	Ceramic: 43 pF ±5%, 50 VDCW, temp coef 0 ±30 PPM/°C. (Used in G1).
C77	19A702236P42	Ceramic: 47 pF ±5%, 50 VDCW, temp coef 0 ±30 PPM/°C. (Used in G3, G6, G8 & G17).
C77	19A702236P36	Ceramic: 27 pF ±5%, 50 VDCW, temp coef 0 ±30 PPM/°C. (Used in G10).
C78	19A702236P38	Ceramic: 33 pF ±5%, 50 VDCW, temp coef 0 ±30 PPM/°C. (Used in G1, G3, G6, G8, G13 & G17).
C78	19A702236P40	Ceramic: 39 pF ±5%, 50 VDCW, temp coef 0 ±30 PPM/°C. (Used in G10).
C79	19A702236P21	Ceramic: 6.8 pF ±0.5 pF, 50 VDCW, temp coef 0 ±60 PPM/°C. (Used in G1,
C79	19A702236P13	Ceramic: 3.3 pF ±5%, 50 VDCW, temp coef 0 ±30 PPM/°C. (Used in G6).
C79	19A702236P17	Ceramic: 4.7 pF ±5%, 50 VDCW, temp coef 0 ±30 PPM/°C. (Used in G8 & G17).
C79	19A702236P28	Ceramic: 12pF, ±5%, 50 VDCW, temp coef 0±30 PPM/°C. (Used in G13).
C80	19A702236P28	Ceramic: 12 pF ±5%, 50 VDCW, temp coef 0 ±30 PPM/°C. (Used in G1 & G10).
C80	19A702236P23	Ceramic: 8.2 pF ±25 pF, 50 VDCW, temp coef 0 ±30 PPM/°C. (Used in G3).
C80	19A702236P25	Ceramic: 10 pF ±5 pF, 50 VDCW, temp coef 0 ±30 PPM/°C. (Used in G6).

* COMPONENTS, ADDED, DELETED OR CHANGED BY PRODUCTION CHANGES

SYMBOL	PART NO.	DESCRIPTION
C80	19A702236P21	Ceramic: 6.8 pF ±0.5 pF, 50 VDCW, temp coef 0 ±60 PPM/°C. (Used in G8,G17).
C80	19A702236P30	Ceramic: 15pF, ±5%, 50 VDCW, temp coef 0±30 PPM/°C. (Used in G13).
C81	19A702236P17	Ceramic: 4.7 pF ±5%, 50 VDCW, temp coef 0 ±30 PPM/°C. (Used in G1 & G10).
C81	19A702236P18	Ceramic: 5.1 pF ±0.5 pF, 50 VDCW, temp coef 0 ±60 PPM/°C. (Used in G3).
C81	19A702236P21	Ceramic: 6.8 pF ±0.5 pF, 50 VDCW, temp coef 0 ±60 PPM/°C. (Used in G6).
C81	19A702236P10	Ceramic: 2.2 pF ±2.5 pF, 50 VDCW, temp coef 0 ±30 PPM/°C. (Used in G8,G17).
C81	19A702236P25	Ceramic: 10pF, ±0.5pF, 50 VDCW, temp coef 0±30 PPM/°C. (Used in G13).
C82	344A3431P1	Ceramic: 1 µF ±10%, 16 VDCW.
C83	19A702052P34	Ceramic: .1 µF ±10%, 25 VDCW.
C84	19A702061P77	Ceramic: 470 pF ±5%, 50 VDCW, temp coef 0 ±30 PPM/°C. (Used in G8,G17).
C85	19A702052P10	Ceramic: 4700 pF ±10%, 50 VDCW. (Used in G13).
C86 and C87	19A702236P50	Ceramic: 100 pF ±5%, 50 VDCW, temp coef, 0±30 PPM/°C. (Used in G13).
C100	19A705205P6	Tantalum: 10 µF, 16 VDCW; sim to Sprague 293D.
C102	19A702236P34	Ceramic: 22 pF ±5%, 50 VDCW, temp coef 0 ±30 PPM/°C. (Used in G17).
----- DIODES -----		
D1 and D2	19A702525P2	Silicon, PIN: sim to MMBV3401.
D3	19A705377P4	Silicon, Hot Carrier: sim to HSMS-2802.
----- FILTERS -----		
FL1	19A705458P4	Helical, UHF: 403-425 MHz. (Used in G1 and G10).
FL1	19A705458P6	Helical, UHF: 492-515 MHz. (Used in G8).
FL1	19A705458P1	Helical, UHF: 450-470 MHz. (Used in G6 & G13).
FL1	19A705458P2	Helical, UHF: 470-492 MHz. (Used in G3).
FL1	19A705458P10	Helical, UHF: 485-505 MHz. (Used in G17).
FL2	19A149974G12	Filter, Crystal. (Used in G17).
FL2	19A705328P6	Monolithic Crystal: 45 MHz; sim to Toycom 45E2B2.
FL3	19B801021P1	Bandpass: 455 kHz; sim to Murata CFW-455D.
FL3	19B801021P7	Bandpass: 455 kHz; sim to Murata CFWS-455G. (Used in G17).
FL4	19A705458P10	Helical, UHF: 485-505 MHz. (Used in G17).
FL4	19A705458P4	Helical, UHF: 403-425 MHz. (Used in G1 & G10).
FL4	19A705458P2	Helical, UHF: 470-492 MHz. (Used in G3).
FL4	19A705458P1	Helical, UHF: 450-470 MHz. (Used in G6 & G13).
FL4	19A705458P6	Helical, UHF: 492-515 MHz. (Used in G8).
----- JACKS -----		
J101	19A149614P1	Connector: 5 sockets; sim to DuPont 69755-005.
J102	19A149614P2	Connector: 11 sockets; sim to DuPont 69755-011.
----- INDUCTORS -----		
L1	19A700024P13	Coil, RF: 1.0 µH ±10%.
L2	19B800937P2	Coil, RF: 0.023 nH; sim to Paul Smith SK-887-1. (Used in G1, G6, G10 & G13).
L2 and L3	19B800937P1	Coil, RF: 0.0153 nH; sim to Paul Smith SK-887-1. (Used in G3, G8 & G17).
L3	19B800937P2	Coil, RF: 0.023 nH; sim to Paul Smith SK-887-1. (Used in G1, G6, G10 & G13).
L4	19B800937P2	Coil, RF: 0.023 nH; sim to Paul Smith SK-887-1. (Used in G1, G6, G10 & G13).

SYMBOL	PART NO.	DESCRIPTION
L4	19B800937P1	Coil, RF: 0.0153 nH; sim to Paul Smith SK-887-1. (Used in G3, G8 & G17).
L5	19A700024P5	Coil, RF: 220 nH ±10%.
L6 thru L8	19A700024P13	Coil, RF: 1.0 µH ±10%.
L9	19B800938P2	Coil, RF: sim to Paul Smith SK-888-1.
L12	19A705470P14	Coil, Fixed: 0.12 µH; sim to Toko 380NB-R12M.
L13	19A705470P21	Coil, Fixed: 0.47 µH; sim to Toko 380NB-R47M.
L14	19A705470P3	Coil, Fixed: 15 nH; sim to Toko 380NB-15nM. (Used in G1).
L14	19A705470P2	Coil, Fixed: 12 nH; sim to Toko 380NB-12nM. (Used in G3, G8 & G17).
L14	19A705470P1	Coil, Fixed: 10 nH; sim to Toko 380NB-10nM. (Used in G6).
L14	19A705470P4	Coil, Fixed: 18 nH; sim to Toko 380NB-18nM. (Used in G10).
L14 and L15	19A705470P5	Coil, Fixed: 22nH; sim to Toko 380NB-22nM (Used in G13).
L15	19A705470P3	Coil, Fixed: 15 nH; sim to Toko 380NB-15nM. (Used in G1).
L15	19A705470P2	Coil, Fixed: 12 nH; sim to Toko 380NB-12nM. (Used in G3,G6, G8, G17).
L15	19A705470P4	Coil, Fixed: 18 nH; sim to Toko 380NB-18nM. (Used in G10).
L16	19B800937P10	Coil, RF: 0.115 nH; sim to Paul Smith SK-887-1.
L17	19A700024P14	Coil, RF: 1.2 µH ±10%.
L18	19A705470P4	Coil, Fixed: 18 nH; sim to Toko 380NB-18nM. (Used in G1 & G10).
L18 and L19	19A705470P3	Coil, Fixed: 15 nH; sim to Toko 380NB-15nM. (Used in G13).
L18	19A705470P5	Coil, Fixed: 22 nH; sim to Toko 380NB-22nM. (Used in G3, G6, G8, G17).
L19	19A705470P4	Coil, Fixed: 18 nH; sim to Toko 380NB-18nM. (Used in G1, G6 & G10).
L19	19A705470P5	Coil, Fixed: 22nH; sim to Toko 380NB-22nM. (Used in G3, G8 & G17).
L20	19A705470P18	Coil, Fixed: 0.27 µH; sim to Toko 380NB-R27M.
----- TRANSISTORS -----		
Q1	19A149542P1	Silicon, PNP: sim to Motorola MJD32C-1.
Q2	19A704708P2	Silicon, NPN: sim to NEC 2SC3356.
Q3	19A703654P2	Silicon, NPN: sim to Motorola MMBR901.
Q4	19A702504P2	Silicon, PNP: sim to 2N4403.
Q5	19A700076P2	Silicon, NPN: sim to MMBT3904.
----- RESISTORS -----		
R1	19B801251P560	Metal film: 56 ohms ±5%, 1/10 w.
R4	19B801251P471	Metal film: 470 ohms ±5%, 1/10 w. (Used in G1, G3, G6 and G10).
R5	19B801251P120	Metal film: 12 ohms ±5%, 1/10 w. (Used in G1, G3, G6 and G10).
R6	19B801251P471	Metal film: 470 ohms ±5%, 1/10 w. (Used in G1, G3, G6 and G10).
R7	19B801251P222	Metal film: 2.2K ohms ±5%, 1/10 w.
R8 and R9	19B801251P100	Metal film: 10 ohms ±5%, 1/10 w.
R10	19B801251P104	Metal film: 100K ohms ±5%, 1/10 w.
R11	19B801251P393	Metal film: 39K ohms ±5%, 1/10 w. (Used in G1, G6, G13).
R11	19B801251P104	Metal film: 100K ohms ±5%, 1/10 w. (Used in G3, G10).
R11	19B801251P273	Metal film: 27K ohms ±5%, 1/10 w. (Used in G17).

SYMBOL	PART NO.	DESCRIPTION
R12 and R13	19B801251P100	Metal film: 10 ohms ±5%, 1/10 w.
R14	19B801251P331	Metal film: 330 ohms ±5%, 1/10 w.
R15 and R16	19B801251P103	Metal film: 10K ohms ±5%, 1/10 w.
R17	19B801251P331	Metal film: 330 ohms ±5%, 1/10 w.
R18 and R19	19B800779P10	Variable: 10K ohms ±25%, .3 w.
R20	19B801251P391	Metal film: 390 ohms ±5%, 1/10 w.
R21	19B801251P223	Metal film: 22K ohms ±5%, 1/10 w.
R22	19B801251P103	Metal film: 10K ohms ±5%, 1/10 w.
R23	19B801251P100	Metal film: 10 ohms ±5%, 1/10 w.
R24	19B801251P821	Metal film: 820 ohms ±5%, 1/10 w.
R25	19B801251P183	Metal film: 18K ohms ±5%, 1/10 w.
R27	19B801251P104	Metal film: 100K ohms ±5%, 1/10 w.
R28	19B801251P822	Metal film: 8.2K ohms ±5%, 1/10 w.
R29	19B801251P100	Metal film: 10 ohms ±5%, 1/10 w.
R30	19B801251P102	Metal film: 1K ohms ±5%, 1/10 w.
R31	19B801251P102	Metal film: 1K ohms ±5%, 1/10 w.
R32	19B801251P100	Metal film: 10 ohms ±5%, 1/10 w.
R33	19B801251P182	Metal film: 1.8K ohms ±5%, 1/10 w.
R34	19B801251P102	Metal film: 1K ohms ±5%, 1/10 w. (Used in G1, G3, G6, G10, G11).
R34	19B801251P272	Metal film: 2.7K ohms ±5%, 1/10 w. (Used in G17).
R35	19B801251P104	Metal film: 100K ohms ±5%, 1/10 w.
R37	19B801251P100	Metal film: 10 ohms ±5%, 1/10 w.
R38	19B801251P103	Metal film: 10K ohms ±5%, 1/10 w.
R39	19B801251P102	Metal film: 1K ohms ±5%, 1/10 w.
R40	19B801251P100	Metal film: 10 ohms ±5%, 1/10 w.
R41	19B801251P331	Metal film: 330 ohms ±5%, 1/10 w.
R42	19B801251P151	Metal film: 150 ohms ±5%, 1/10 w.
R43 thru R45	19B801251P102	Metal film: 1K ohms ±5%, 1/10 w.
R48	19B801251P472	Metal film: 4.7K ohms ±5%, 1/10 w. (Used in G1, G3, G6 and G10).
R49	19B801251P472	Metal film: 4.7K ohms ±5%, 1/10 w. (Used in G1, G3, G6 and G10).
R53	19B801251P680	Metal film: 68 ohms ±5%, 1/10 w.
R54 and R55	19B801251P103	Metal film: 10K ohms ±5%, 1/10 w.
R75	19B801251P100	Metal film: 10 ohms ±5%, 1/10 w.
R76	19B801251P182	Metal film: 1.8K ohms ±5%, 1/10 w.
R77	19B801251P152	Metal film: 1.5K ohms ±5%, 1/10 w.
R78	19B801251P472	Metal film: 4.7K ohms ±5%, 1/10 w.
R79	19B801251P104	Metal film: 100K ohms ±5%, 1/10 w. (Used in G17).
R80	19B800607P510	Metal film: 51 ohms ±5%, 1/10 w. (Used in G17).
----- SWITCHES -----		
SW1A	19B235072P1	Spring, Antenna Switch.
SW1B	19B235071P1	Spring, Antenna Switch.
SW1C	19C337027P1	Housing, Antenna Switch.

SYMBOL	PART NO.	DESCRIPTION
----- TRANSFORMERS -----		
T1	19A703591P2	IF: sim to Toko America 332PN-T1016Z.
T2	19A703591P1	IF: sim to Toko America P5SVLC-A291EL.
----- INTEGRATED CIRCUITS -----		
U1	19B800902P4	Digital: Synthesizer, CMOS Serial Input.
U2	19A704287P2	Prescaler: /128/129; sim to MC12018.
U3	19B801351P15	Module: Crystal Oscillator, 13.2 MHz ±2.5 PPM. (Used in G1,G3,G6,G8,G10,G13).
U3	19B801351P26	Module: Crystal Oscillator, 12.8 MHz ±3 PPM. (Used in G17).
U4	19A705419P1	Module: UHF RF PA; MHW-707-1. (Used in G1).
U4	19A705419P3	Module: UHF RF PA; MHW-707-3. (Used in G3).
U4	19A705419P2	Module: UHF RF PA; MHW-707-2. (Used in G6 & G13).
U4	19A705419P4	Module: UHF RF PA; MHW-707-4. (Used in G8 & G17).
U4	19A705419P5	Module: UHF RF PA; MHW-707. (Used in G10).
U5	19A705706P2	Module: UHF Mixer; sim to TSM-111.
U6	19A704619P1	Linear: Osc/Mixer/IF/DET/Amp; sim to MC3361AP.
----- CRYSTALS -----		
Y1	19A705376P5	Fixed Frequency: 45.455 MHz ±10 PPM.
RF BOARD MISCELLANEOUS (See Drawing 19D902282)		
6	19A149008P1	Pad. (Supports Y1).
7	19A149009P1	Pad. (Supports Y1).
8	19A121175P39	Insulator, plate. (Used with Q1).
9	19A705701P104	Screw, Machine: Torx, Pan Head; M2 x 4.
10	19D438351P1	Casting, Eggcrate.
11	19A705701P104	Screw, Machine: Torx, Pan Head; M2 x 4.
12	19A705701P206	Screw, Machine: Torx, Pan Head; M2.5 x 6.
13	19B234990P1	Support, PA Module. (Used with U4).
14	19A705853P1	Screw, Thread Forming. (Secures SW1).
16	19A705871P2	Clip, Ground. (Used with FL2).
18	19C851898P1	Shim, Ground. (Used with U4).
23	344A3853P1	Insulator, washer.
28	19B801566P13	Shield. (Used in G17).

**REAR COVER ASSEMBLY
MISCELLANEOUS
(See Drawing 19C337097)**

SYMBOL	PART NO.	DESCRIPTION
2	19A115983P16	O-Ring, Rubber; .370" ID.
3	19B801618P1	Insert, Antenna.
4	19B235133P1	Connector, UDC RF.
5	19D438535P1	Shield. (Covers RF Board).
6	19B801598G1	Cover, Rear. (See Separate Parts List).
7	19A705701P114	Screw, Machine: Torx, Pan Head; M2 x 14.
8	19A705701P104	Screw, Machine: Torx, Pan Head; M2 x 4.
9	19D902326P1	Label, Tracking Card.
14	19B234763P17	Pad.

**REAR COVER
19B801598G1
ISSUE 2**

SYMBOL	PART NO.	DESCRIPTION
		MISCELLANEOUS
2	19B235075P2	Plate, Receptacle.
3	N327P9009Y6	Rivet. (Qty = 4)
4	19D902730P1	Gasket, Outer Seal.
5	19A705728P1	Screw, Machine: Torx T6 Oval Head; M2.6 x 14. (Secures Front and Rear Cover Assemblies, qty = 2).
6	19A705728P2	Screw, Machine: Torx T6 Oval Head; M2.6 x 23. (Secures Front and Rear Cover Assemblies, qty = 2).
7	19A701365P7	Washer. (Used with above Screws,, qty = 4).
8	19C851743P1	Cover.

PRODUCTION CHANGES

Changes in the equipment to improve performance or to simplify circuits are identified by a "Revision Letter", which is stamped after the model number of the unit. The revision stamped on the unit includes all previous revisions. Refer to the Parts List for the descriptions of parts affected by these revisions.

REV. A - RF BOARD 19D902282G6
Incorporated changes necessary for the release of the 19D902282G1, G3 and G8 RF Boards.

REV. A - REAR COVER ASSEMBLY 19C337097G7

REV. A - RF BOARD 19D902282G8
To improve transmitter performance, made the following changes in the harmonic filter circuit between the VCO and PA IC: added C84 and deleted R4, R5, R6, R48 and R49. Earlier components were:
R419B801251P182Metal film: 1.8K ohms ±5%.
R519B801251P5R6Metal film: 5.6 ohms ±5%.
R619B801251P182Metal film: 1.8K ohms ±5%.
R4819B801251P182Metal film: 1.8K ohms ±5%.
R4919B801251P182Metal film: 1.8K ohms ±5%.

REV. A - REAR COVER ASSEMBLY 19C337097G4 - G6

REV. A - RF BOARD 19D902282G1 & G3
No changes.

REV. B - REAR COVER ASSEMBLY 19C337097G4 - G7

REV. B - RF BOARD 19D902282G1, G3, G6 and G8
To improve transmit power control circuitry, removed driver transistor Q5 and added diode D4. Also removed R2 and R3 and changed C65, C83 and R39. Earlier components were:
C6519A702052P14Ceramic: 0.01 µF ±10%, 50 VDCW.
C8319A702052P14Ceramic: 0.01 µF ±10%, 50 VDCW.
Q519A700076P2Silicon, NPN: sim to MMBT3904.
R219B801251P103Metal film: 10K ohms ±5%.
R319B801251P472Metal film: 4.7K ohms ±5%.
R3919B801251P102Metal film: 1K ohms ±5%, 1/10 w.

Earlier (Rev. A) schematic was:

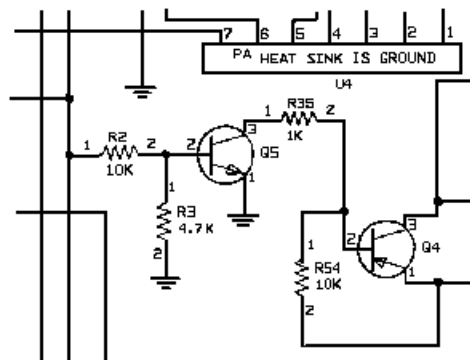

REV. C - REAR COVER ASSEMBLY 19C337097G4 - G7

REV. C - RF BOARD 19D902282G1, G3, G6, G8 & G17
To improve squelch operation at high operating temperatures changed 455 kHz IF filter FL3 from 19B801021P2 to 19B801021P1.

REV. D - RF BOARD 19D902282G1, G3, G6 and G8

REV. A - RF BOARD 19D902282G10
To improve production process, changed C17, C18, C49, C52, C63, C64, C73, C75 and C82 from polarized tantalum capacitors (19A705205P2) to non-polarized ceramic capacitors (344A3431P1). Also changed C41 - C43 from 19A702052P26 to 19A702052P34.

REV. B - RF BOARD 19D902282G10

No change.

REV. C - RF BOARD 19D902282G10

No change.

REV. D - RF BOARD 19D902282G10

No change.

REV. D - REAR COVER ASSEMBLY 19C337097G4 - G7

REV. E - RF BOARD 19D902282G1, G3, G6, G8, G10

To improve operation, changed A5 from 19C852056G1 to 19C852056G3, changed C83 from 1000 pF (19A702052P5) to .1 µF (19A702052P34), added C100, deleted D4 (19A702525P2) and added Q5. Also changed R11 (G1 and G10 only) from 33K ohms (19B801251P333) to 100K ohms (19B801251P104), changed R11 (G3, G6 and G8 only) from 27K ohms (19B801251P273) to 100K ohms (19B801251P104), changed R30 from 2.7K ohms (19B801251P272) to 1K ohms (19B801251P102), and changed R39 from 100 ohms (19B801251P101) to 1K ohms (19B801251P102). In addition, added R75 - R78. Earlier transmit power control circuitry schematic was:

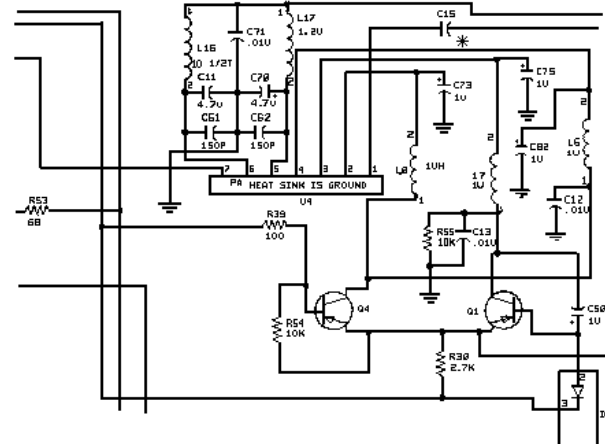

REV. E - REAR COVER ASSEMBLY 19C337097G4-G7

REV. A - REAR COVER ASSEMBLY 19C3370897G11 & G13

REV. F - RF BOARD 19D902282G1, 3, 6, 8, 10

REV. A - RF BOARD 19D902282G13

To correct TX motor boating when battery is at a low voltage level. R75 was 10 ohms (19B801251P100).

REV. G - RF BOARD 19D902282G1, 3, 6, 8, 10

REV. B - RF BOARD 19D902282G13

Improve operation of reference oscillator (Toyocomm version) U3, C30 was removed and replaced with two 2.2µF Tantalum capacitors C30 and C88 (19A705205P19). 820K ohms resistor R80 (19B801251P824) added in parallel with C49.

REV. H - RF BOARD 19D902282G1, 6

REV. C - RF BOARD 19D902282G13

To improve trunking accuracy, synthesizer resistor R11 changed from 100K ohms to 39K ohms (19B801251P393).

REV. J - RF BOARD 19D902282G1, 6

REV. D - RF BOARD 19D902282G13

REV. H - RF BOARD 19D902282G3, 8, 10

Improve operation of reference oscillator (NDK version) U3, changed C30 to 10µF Tantalum (19A705205P6) and removed C88 and R80.

REV. A - RF BOARD 19D902282G17

To improve receiver IF spur rejection. Added C102 and R80.

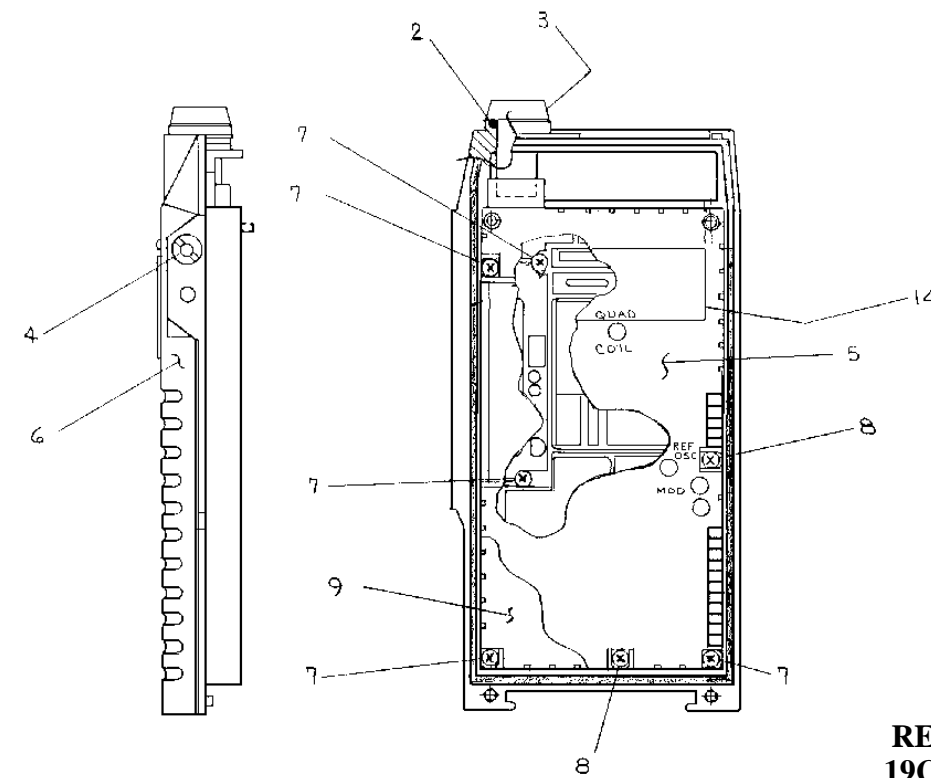

TORQUE SPECIFICATIONS

ITEM	LB. - IN.
3	10.0
4	5.0
7	4.0
8	4.0

**REAR COVER ASSEMBLY
19C337097G4 - G7, G11, G13**

(19C337097, Sheet 1, Rev. 9)

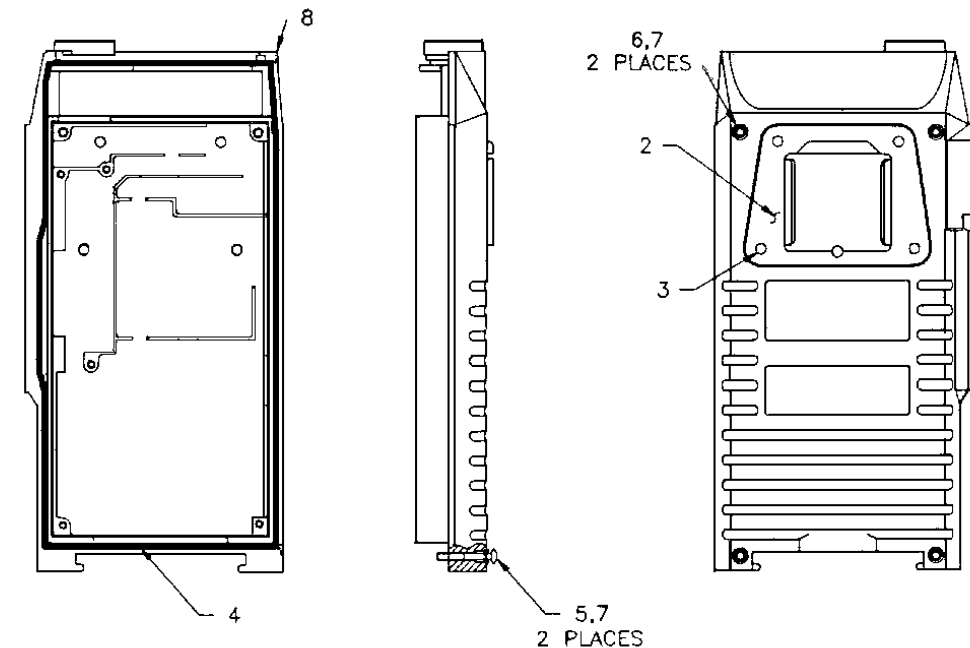

**REAR COVER
19B801598G1**

(19B801598, Sheet 1, Rev. 7)

19D902282G1, 3, 6, 8, 10, 17

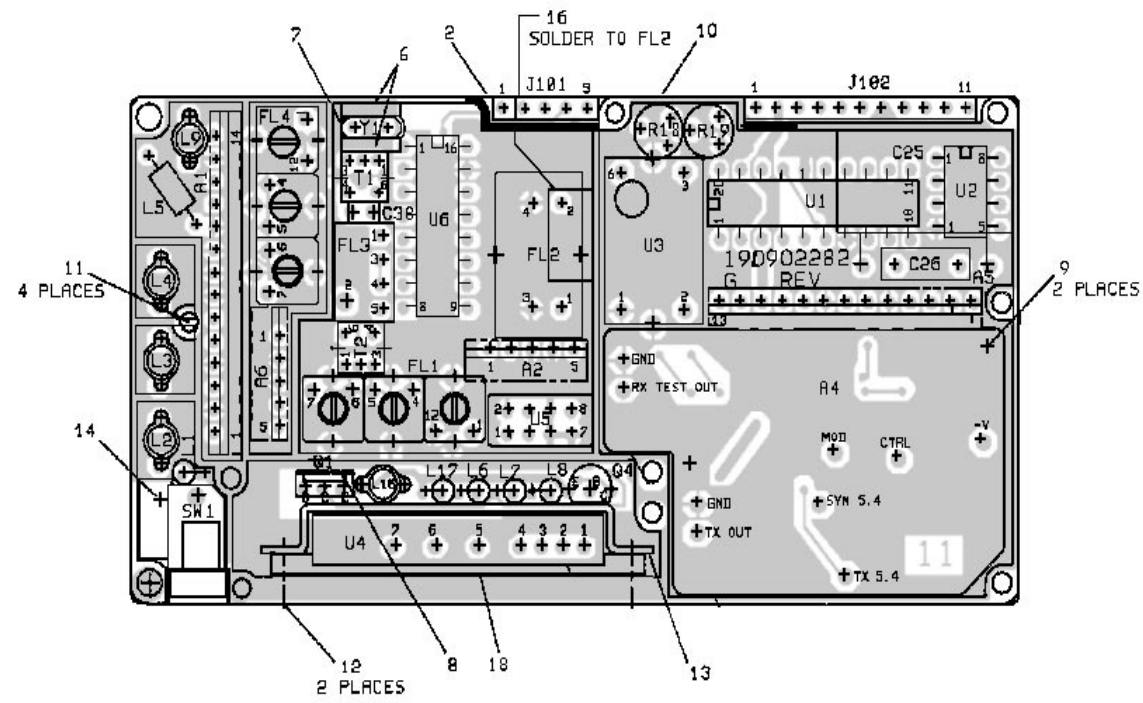

(19D902282, Sh. 1, Rev. 15)
(19D902283, Comp. Side, Rev. 11)

19D902282G13

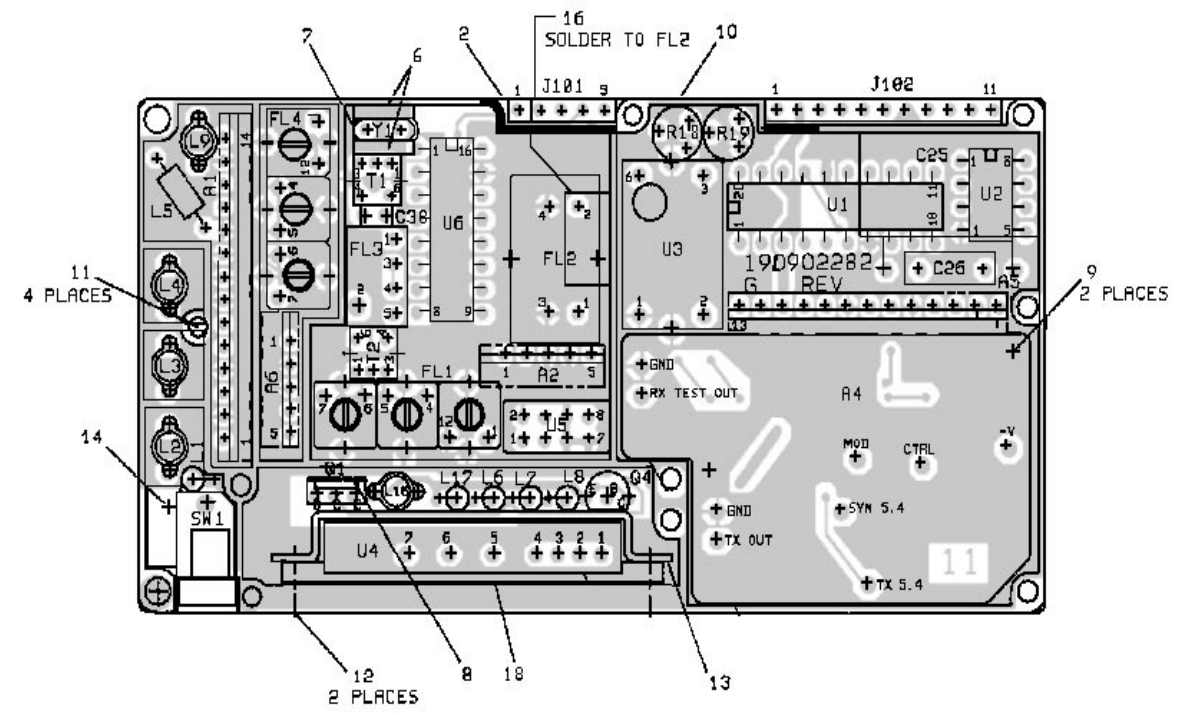

(19D902282, Sh. 2, Rev. 15)
(19D902283, Comp. Side, Rev. 11)

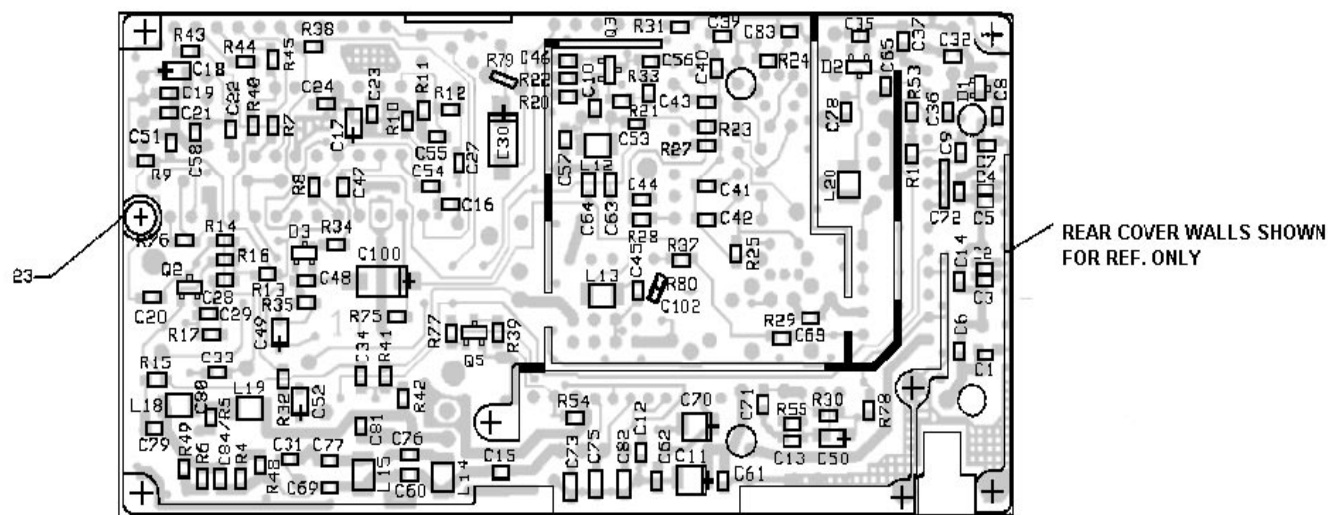

(19D902282, Sh. 1, Rev. 15)
(19D902283, Solder Side, Rev. 11)

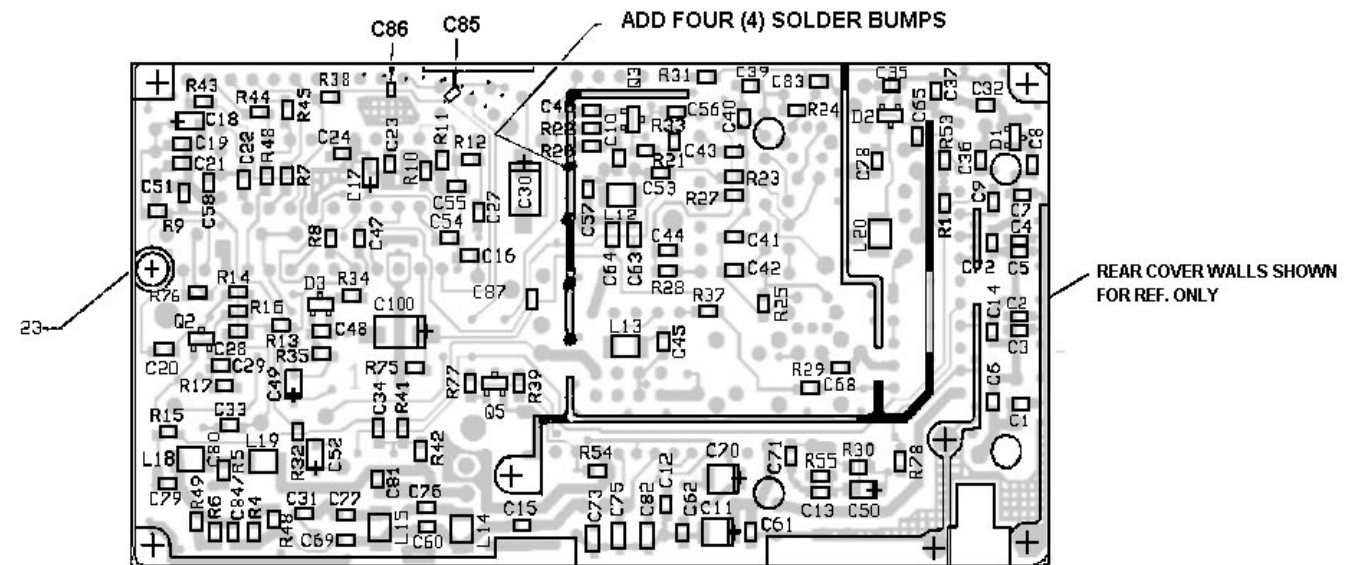

(19D902282, Sh. 2, Rev. 15)
(19D902283, Solder Side, Rev. 11)

RF BOARD
19D902282G1, G3, G6, G8, G10, G13, G17



CAUTION
OBSERVE PRECAUTIONS
FOR HANDLING
ELECTROSTATIC
SENSITIVE
DEVICES

CHIP IDENTIFICATION
TOP VIEW

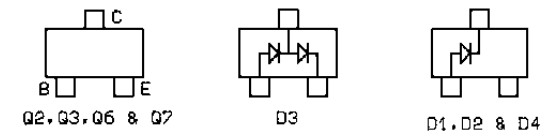

SCHMATIC DIAGRAM

LBI-38383H

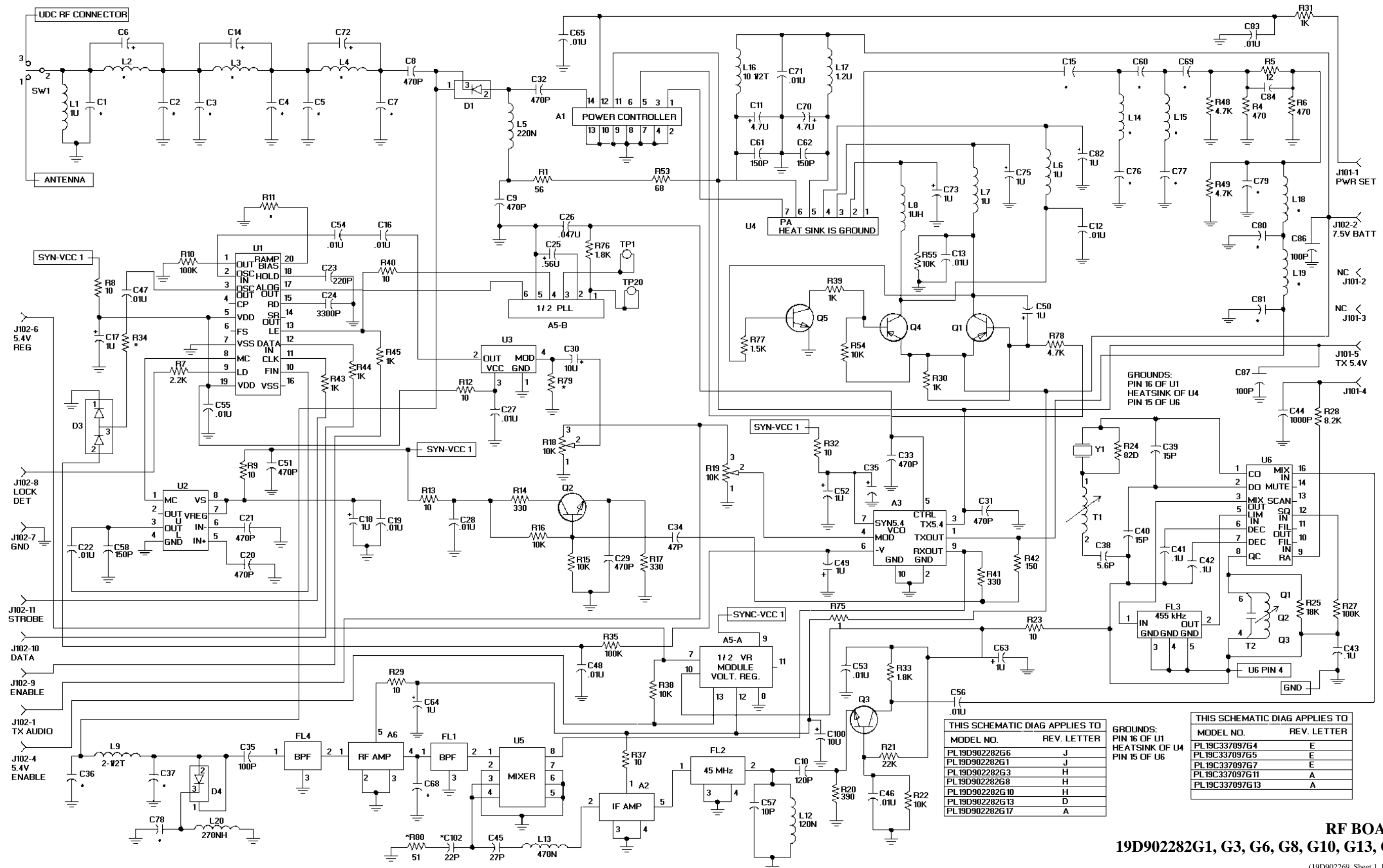

THIS SCHEMATIC DIAG APPLIES TO

MODEL NO.	REV. LETTER
PL19D902282G6	J
PL19D902282G1	J
PL19D902282G3	H
PL19D902282G8	H
PL19D902282G10	H
PL19D902282G13	D
PL19D902282G17	A

THIS SCHEMATIC DIAG APPLIES TO

MODEL NO.	REV. LETTER
PL19C337097G4	E
PL19C337097G5	E
PL19C337097G7	E
PL19C337097G11	A
PL19C337097G13	A

RF BOARD
19D902282G1, G3, G6, G8, G10, G13, G17

(19D902269, Sheet 1, Rev. 18)