

**MAINTENANCE MANUAL
RADIO
FRONT ASSEMBLY
19D902177G5 (2 CHANNELS)
19D902177G6 (8 CHANNELS)**

TABLE OF CONTENTS	
	Page
DESCRIPTION	1
Front Cap Assembly	1
Audio/Logic Board	1
CIRCUIT ANALYSIS	1
Front Cap Assembly	1
Control Switches	1
LCD Assembly	1
Microphone And Speaker	1
User Device Connector (UDC)	1
Audio/Logic Board	1
Microprocessor (80C51)	1
Microprocessor Port/Pin Definitions	1
EEPROM	2
Rx Audio Processing	2
Voice Path	2
Squelch Path	3
Limited Tone Data Path	3
TX Audio Processing	3
Regulators And Special Circuitry	3
+5 Volt Regulator	3
Low Voltage Reset	3
Figure 5 - Voltage Waveforms	3
Low Battery Indicator	3
User Input	3
Synthesizer Programming	3
Alert Tone	4
Microprocessor Xtal Frequency Pull	4
PARTS LIST	8
IC DATA	10

(Continued)

TABLE OF CONTENTS (Continued)	
	Page
OUTLINE DIAGRAMS:	
Front Cap Assembly	12
LCD Driver Board	12
Spur Filter Board	12
Audio/Logic Board	13
SCHEMATIC DIAGRAMS:	
Spur Filter Board	14
Front Cap Assembly	15
Audio/Logic Board	16
FIGURES:	
Figure 1 - Front Assembly	1
Figure 2 - Microprocessor Block Diagram	2
Figure 3 - Audio Paths Block Diagram	3
Figure 4 - Audio Response Curve	4
Figure 5 - Voltage Waveforms	4
Figure 6 - Alert Tone Sequences	4
Figure 7 - RX Squelch Operation	5
Figure 8 - RX Channel Guard Operation	5
Figure 9 - RX Type 99 Operation	6
Figure 10 - TX Voice Only Operation	6
Figure 11 - TX Channel Guard Operation	7

DESCRIPTION

The Front Radio Assembly (19D902177) for the PCS™ Personal Synthesized Radio consists of the following:

- Front Cap Assembly 19D902180G1
- Audio/Logic Board 19D902142G3/G4
- Metal Over Elastomer (MOE) Connector 19A705662P1 and Holder 19B801570P2

The Front Cap Assembly consists of a LEXAN front housing, a control assembly and a speaker. The control assembly houses all operator switches, Liquid Crystal Display (LCD) and microphone. The Metal Over Elastomer Connector interfaces the printed runs on the control assembly to the printed runs on the audio/logic board.

FRONT CAP ASSEMBLY

Front Cap Assembly 19D902180G1, for the Ericsson GE PCS™ Personal Radio, consists of a molded plastic circuit board (Control Frame), a Liquid Crystal Display (LCD) assembly, switches for the basic radio functions and a User Device Connector (UDC) all mounted in a plastic front housing. The Assembly Diagram listed in the Table of Contents shows two views: a pictorial view of the Control Assembly and a view of the Control Assembly mounted into the radio front housing. The Control Frame acts like a three dimensional printed circuit board. The base material is "ULTEM" which is a molded plastic with a two layer printed circuit pattern on the outside perimeter of the frame. This structure interfaces several electrical components as follows:

- Control Switches
- Liquid Crystal Display (LCD)
- Microphone
- Speaker
- User Device Connector (UDC)

AUDIO/LOGIC BOARD

Audio/Logic Board 19D902142 mounts in Front Cap Assembly 19D902180G1 as shown in Figure 1. All Front Cap switch operations are connected to the audio/logic board through the MOE interface connector. A microprocessor on the audio/logic board interprets these commands and issues commands to the audio/logic circuits, the RF circuits and the LCD module on the control assembly. The MOE is again the transmission path between assemblies. The microphone and speaker audio is also transferred through the MOE path (Refer to Figure 2 for a block

diagram of the microprocessor and associated circuitry and Figure 3 for a block diagram of the audio paths).

The audio/logic board consists primarily of the following:

- Microprocessor
- EEPROM
- RX Audio Processing
- TX Audio Processing
- Regulators and Special Circuits

CIRCUIT ANALYSIS

FRONT CAP ASSEMBLY

Control Switches

A "Dome" switch pad adheres to the control frame. These switches are domed metal switches which makes direct contact with runs on the control frame. The switches include the PTT, monitor, channel up, volume up and volume down controls. Refer to the Schematic Diagram listed in the Table of Contents for switch operation. A rubber keypad fits over the switch assembly for operator interface and weather protection.

LCD Assembly

The LCD (Liquid Crystal Display) assembly consists of LCD driver board A1, a diffuser, two zebra strips, the LCD and a lens. This assembly is held together by the lens. The primary function of this board is to light LCD segments as controlled by the radio microprocessor located on the audio/logic board. Another function of this board is to provide backlighting of the LCD module. This is accomplished by using four LED devices (D1 - D4). These LED's are turned on by LCD DAT/LT line and powered by a voltage switching circuit consisting of chip transistors Q1 and Q2. The diffuser placed immediately above the LED's evenly distributes the light. The zebra strips connect the driver board to the LCD. This entire assembly is soldered to the control frame through six pins.

Microphone And Speaker

The microphone (B901) mounts directly onto the control frame (HL1 and HL2). The control assembly, when placed into the Radio Front Assembly, is located in the correct position for receiving voice when used. The speaker, mounted in the front housing, connects to the control frame (HL3 and HL4) through

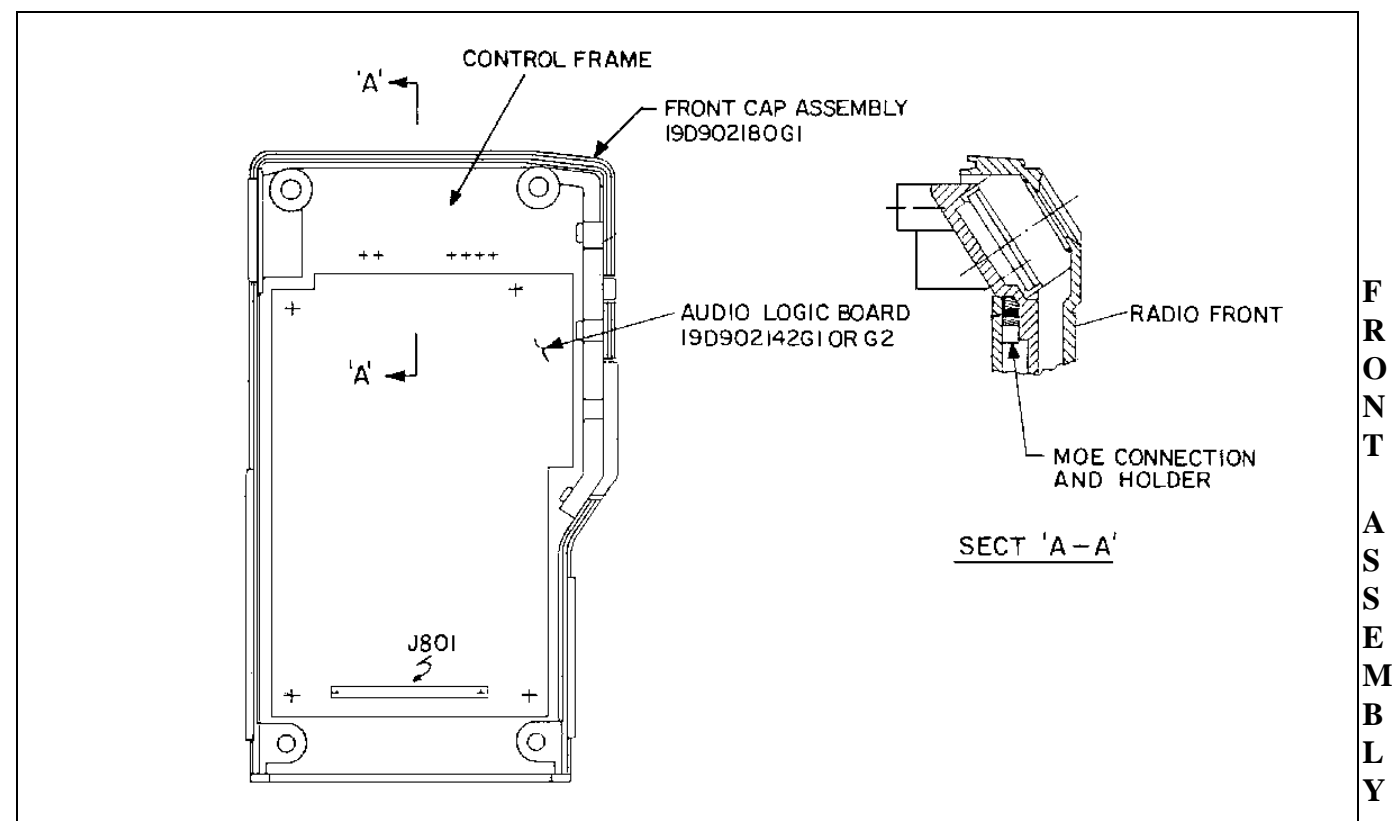

Figure 1 - Radio Front Assembly

two wires. A protective grill cloth is placed over the front housing before the speaker is mounted to provide weather-proofing.

User Device Connector (UDC)

Part of the control frame forms UDC connector U901 for customer programming and for connecting external options. The speaker leads, mic high and PTT are all brought to this connector along with ground. The mic lead and one of the speaker leads are switched to the UDC only when microswitches S1 and S2 are operated. These switches are activated by plungers on compatible PCS Personal Radio options. A rubber boot is placed over this connector for weather protection.

AUDIO/LOGIC BOARD

Microprocessor (80C51)

An 8-bit microprocessor is used to provide all of the control signals required by the radio. The microprocessor also generates Channel Guard tones and detects Channel Guard and Type 99 tones.

The microprocessor (U1) is located on Spur Filter Board A701. This board consist of RC filters on each port of the processor and a metal can soldered on top of the board to reduce the effect of microprocessor-generated spurious signals.

Microprocessor Port/Pin Definitions

Port Pins	I=Input O=Output I/O=Bidirectional
P0.0 (O)	Channel Guard encode bit 0/Volume attenuator bit 0
P0.1 (O)	CG encode bit 1/Volume attenuator bit 1
P0.2 (O)	CG encode bit 2/Volume attenuator bit 2
P0.3 (O)	CG encode bit 3/Voice mute
P0.4 (I)	Low Battery indication (active low)
P0.5 (O)	Transmit CG switch (active high)
P0.6 (O)	Delayed PTT (active high)

P0.7 (O)	Mute (active low)
P1.0 (I)	Monitor (active low)
P1.1 (I)	Vol Up (active low)
P1.2 (I)	Vol Dn (active low)
P1.3 (I)	Ch Up (active low)
P1.4 (I)	CAS (active low)
P1.5 (O)	Xtal switch (active high)
P1.6 (O)	Mic mute (active low)
P1.7 (O)	Power select
P2.0 (O)	LCD enable
P2.1 (O)	LCD data
P2.2 (O)	LCD clock
P2.3 (O)	Receive mute (active high)
P2.4 (O)	Type 99 enable (active high)
P2.5 (O)	Synthesizer clock
P2.6 (O)	Synthesizer data
P2.7 (O)	Synthesizer enable
RXD (I)	Programmer data in
TXD (O)	Programmer data out
P3.2 (I)	Tone data in
P3.3 (I)	Lock detect (active high)
P3.4 (O)	Alert tone
P3.5 (O)	EEPROM power enable
P3.6 (O)	EEPROM clock
P3.7 (I/O)	EEPROM data

- Customer frequencies
- Customer tones
- Customer Options

Using this EEPROM provides the convenience of programming without opening the radio.

Programming of the EEPROM is accomplished by driving the **MIC HI** lead. This lead is connected to operational amplifier circuit U302-B. With no external signal connected to **MIC HI**, a voltage level of approximately 2.25 volts is at **MIC HI**. This causes the output of U302-B, the program data line, to be high. If the **MIC HI** is pulled low, the program data line is pulled low. If this line remains low for 20 milliseconds or greater, the microprocessor is put in the programming mode. Once in this mode, the radio will not operate or respond to any front case button. The radio must be turned off and then back on to get the processor out of this mode. If programming is actually done, the processor will be taken out of the programming mode by the proper character from the personal computer programmer.

RX Audio Processing

Voice Path

Received audio enters the audio/logic board at J801, Pin 10. Frequencies below 300 Hz are attenuated by the Channel Guard reject filter consisting of U602A and associated circuitry.

The output from the CG reject filter is coupled through voice mute switch transistor Q603 to the volume attenuator circuit U602B and resistors R632 through R640. Here the 500 Hz alert tone, generated by the microprocessor, can be added to the received audio. The volume attenuator has a range of 48 dB. The attenuator output is coupled through **RX MUTE** switching transistor Q606 to audio amplifier transistor U604. Power is supplied to the audio amplifier by transistor Q605 and controlled by the **MUTE** line from the microprocessor. Amplifier U604 drives the speaker with differential outputs, which are also connected to the accessory connector through the Control Assembly.

A 6 dB/octave de-emphasis is provided by capacitor C615 and resistor R628 in the CG reject filter. Capacitor C622 and resistor R645 provide additional roll-off at higher frequencies.

EEPROM

The 512 x 8 - bit **EEPROM** (U701), commonly referred to as the personality PROM, stores customer information as follows:

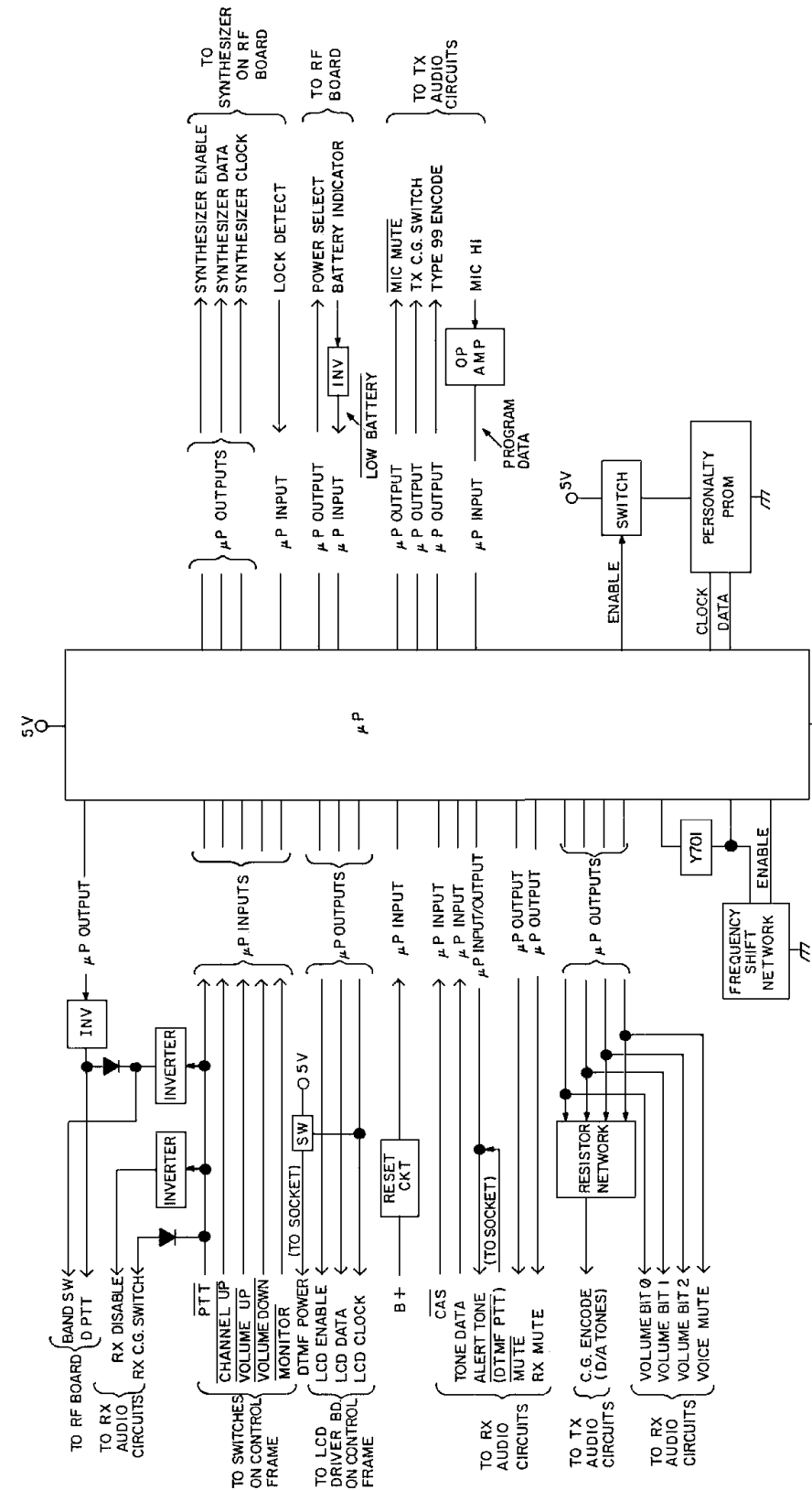

Figure 2 - Microprocessor Block Diagram

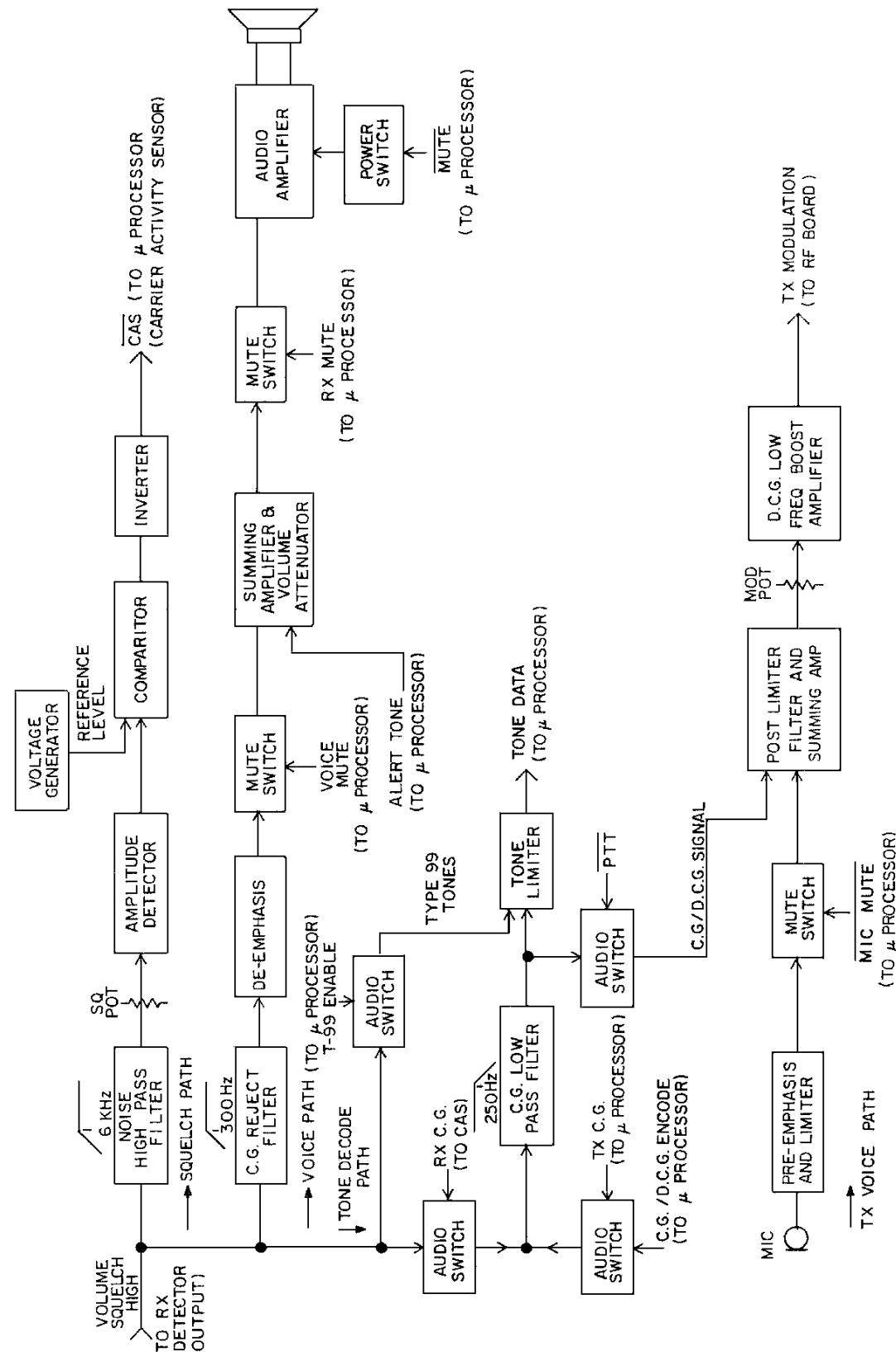

Figure 3 - Audio Paths Block Diagram

Squelch Path

The squelch circuit operates on the noise components contained in the discriminator output. The signal at J801, Pin 10 is applied to a high-pass filter consisting of U601B and associated circuitry. The output of U601B is noise in a band around 6 kHz. The gain of the high-pass filter is determined by squelch potentiometer R608.

The output of U601B is rectified by U601A, resistors R610 through R612 and capacitors C607 and C608. This d.c. signal is then input to comparator U601D. If the rectified noise is more than approximately 0.20 Vd.c., the CAS line is high and the microprocessor mutes the audio. Resistor R613 and R615 provide about 2 dB of hysteresis. Resistors R614, R662, R663 and thermister R664 are used for temperature compensation or the threshold level.

The threshold level is temperature compensated at cold temperatures only. This is necessary because of a drop in the VOL/SQ. HI noise level. Thermister R664 has a negative temperature coefficient. At 25 C and above, the thermister has little effect on the threshold voltage level at U601B, Pin 12. At temperatures below 25 C, the resistance increased exponentially, thereby causing a drop in the threshold voltage. This voltage drop approximately tracks the voltage drop at the detected noise terminal, U601B, Pin 13.

Limited Tone Data Path

Limited Tone Data is the 5 Volts (peak-peak) representation of a received tone and is fed to the microprocessor where the actual tone decoding occurs. This circuit consists of a low-pass filter for voice rejection and a voltage comparator.

The low-pass filter consists of U606A and associated circuitry. This filter is used for both Channel Guard encoding and decoding. The filter has a breakpoint at 210 Hz. Type 99 decoding is done by bypassing the low-pass filter and going directly to comparator U606B.

Tx Audio Processing

Audio from the microphone is applied to a 6 dB/octave pre-emphasis network consisting of capacitor C301 and resistor R306 and then to amplifier-limiter U301A. The output of U301A is coupled through mic mute switch U605C to the post-limiter filter consisting of U302A and associated circuitry. Transmit Channel Guard tones are added to the microphone audio at the post-limiter filter.

The transmit signal is applied to the low-frequency boost circuit U303A, U303B and associated circuitry. The transmit deviation is set by MOD potentiometer R321.

The low frequency boost circuitry provides an increasing output level as the input frequency decreases below 20 Hz. The shape of the response curve is shown in Figure 4. This shape is intended to be the mirror image of the synthesizer frequency response curve. The combined result of these two curves provide relatively flat modulation below 5 Hz. This is necessary for Digital Channel Guard modulation.

Regulator And Special Circuitry

+5 Volt Regulator

A +5 volt regulator (U802) supplies power to the microprocessor and all other circuitry requiring +5 volts. A voltage divider provides the input to U601-C to generate a 2.25 volt reference for operational amplifier biasing.

Low Voltage Reset

Voltage detector U801 along with transistor Q803 provides the microprocessor with the necessary reset signal during the power up routine and also resets the microprocessor when the battery falls below approximately 4.75 volts (Refer to Figure 5).

Low Battery Indicator

When the battery voltage drops to approximately 6.3 volts, the BATT IND line from the RF board is sufficiently high to turn on transistor Q802. The output of Q802, the low battery line, drives a microprocessor port. This action turns on the BATT pixel on the LCD.

User Input

Control assembly connector J901, located on the audio/logic board, provides an interface between the user and the radio. By pressing buttons on the switch panel, the user may change the volume level or channel, monitor a channel, or key the transmitter. The LCD is updated to reflect the current status of the radio. The microprocessor configures the LCD through LCD EN (P2.0), LCD DAT (P2.1) and LCD CLK (P2.2).

Synthesizer Programming

After a reset, when toggling between transmit and receive, and any time a new channel is selected, the microprocessor must reprogram the synthesizer through SYN CLK (P2.5), SYN DAT (P2.6) and SYN EN (P2.7). When locked, the LOCK DET line (J9801-11) is high.

Alert Tone

The microprocessor generates a 500 Hz alert tone (P3.4) used to signal the user of critical events. These events include synthesizer out of lock and activation of the volume up, volume down and channel up buttons. The alert tone can be disabled by the programmer.

Microprocessor Xtal Frequency Pull

Port P1.5 of the microprocessor is used to switch a 33 pf capacitor (C701) into the crystal oscillator circuit. The effect of adding this capacitor is to move or pull the xtal frequency approximately 250 ppm. This is done to keep harmonics of the microprocessor **ALE** line away from the receive channel frequency.

The programming from this point happens automatically when channel frequencies are initially programmed.

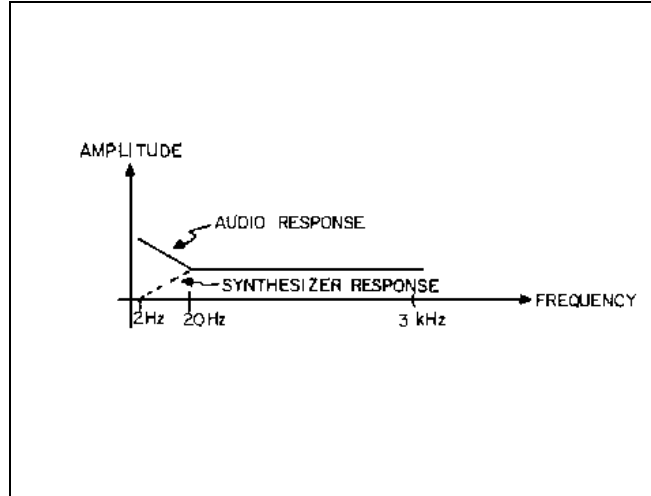

Figure 4 - Audio Response Curve

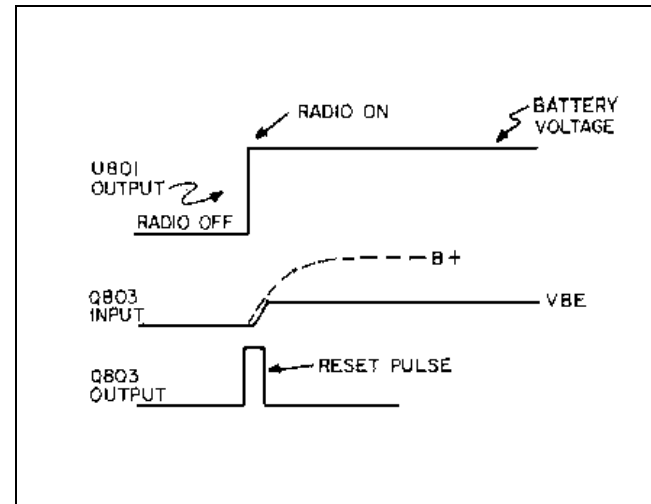

Figure 5 - Voltage Waveforms

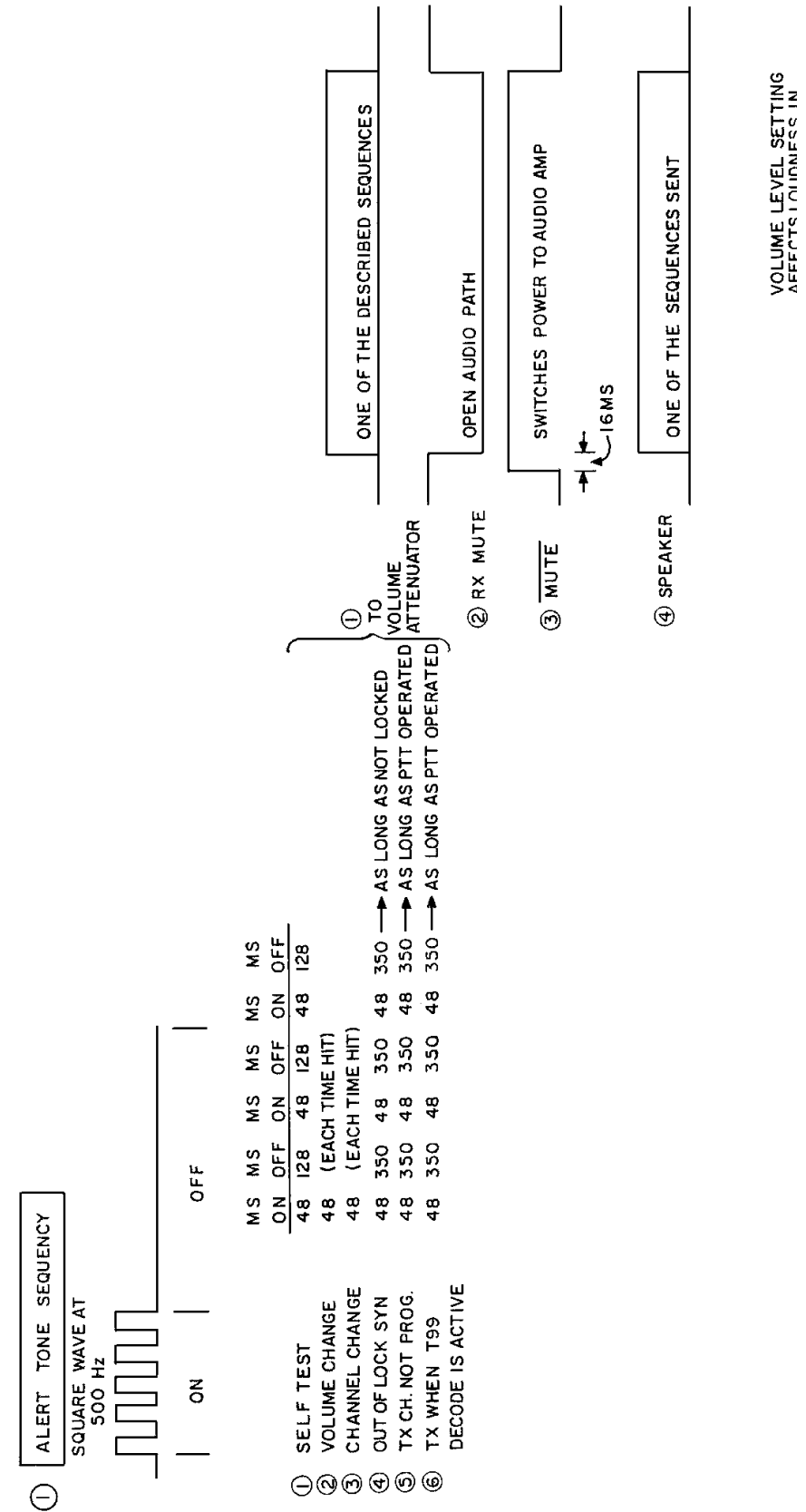

Figure 6 - Alert Tone Sequences

② RX — SQUELCH OPERATION

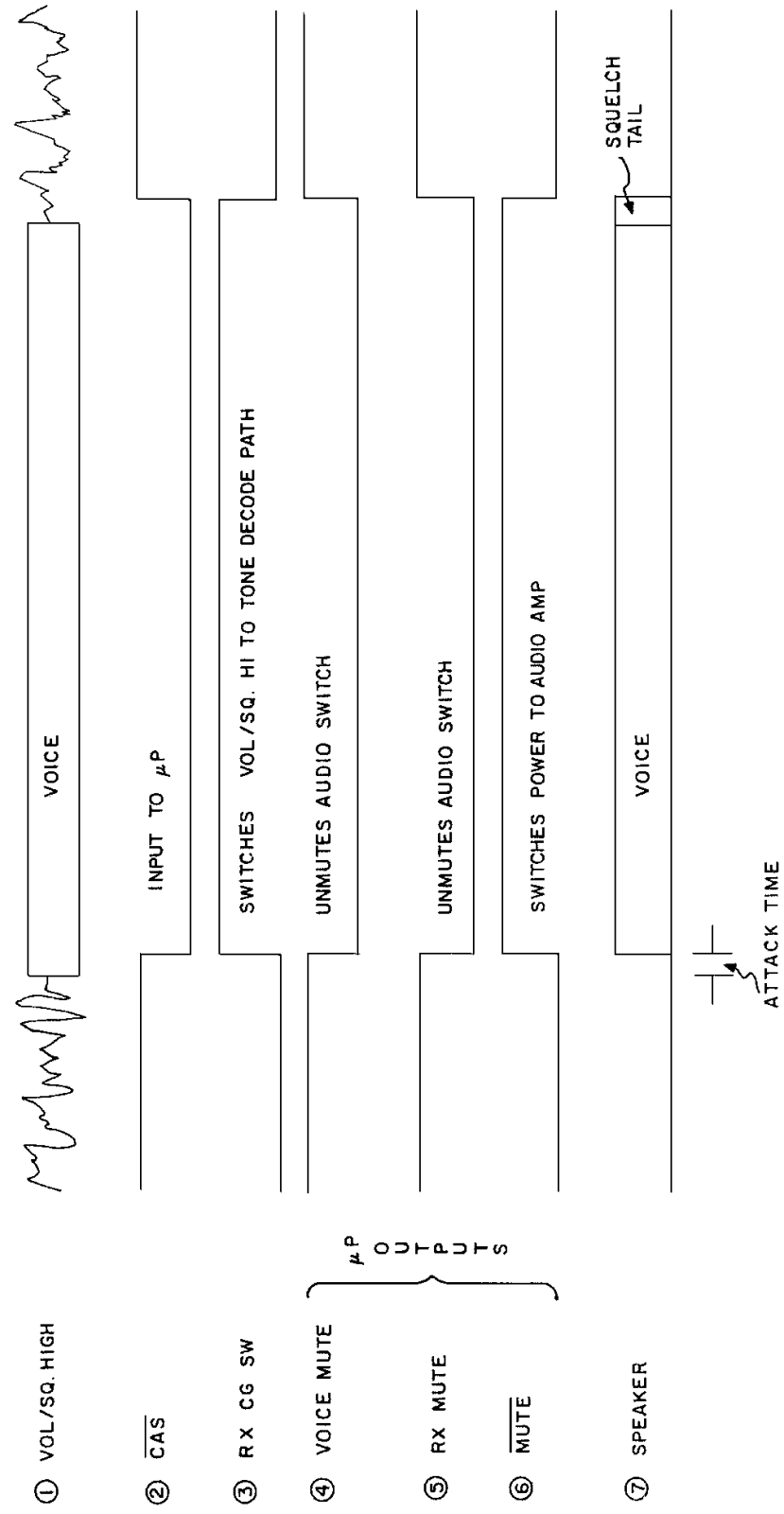

Figure 7 - RX Squelch Operation

③ RX - CG OPERATION

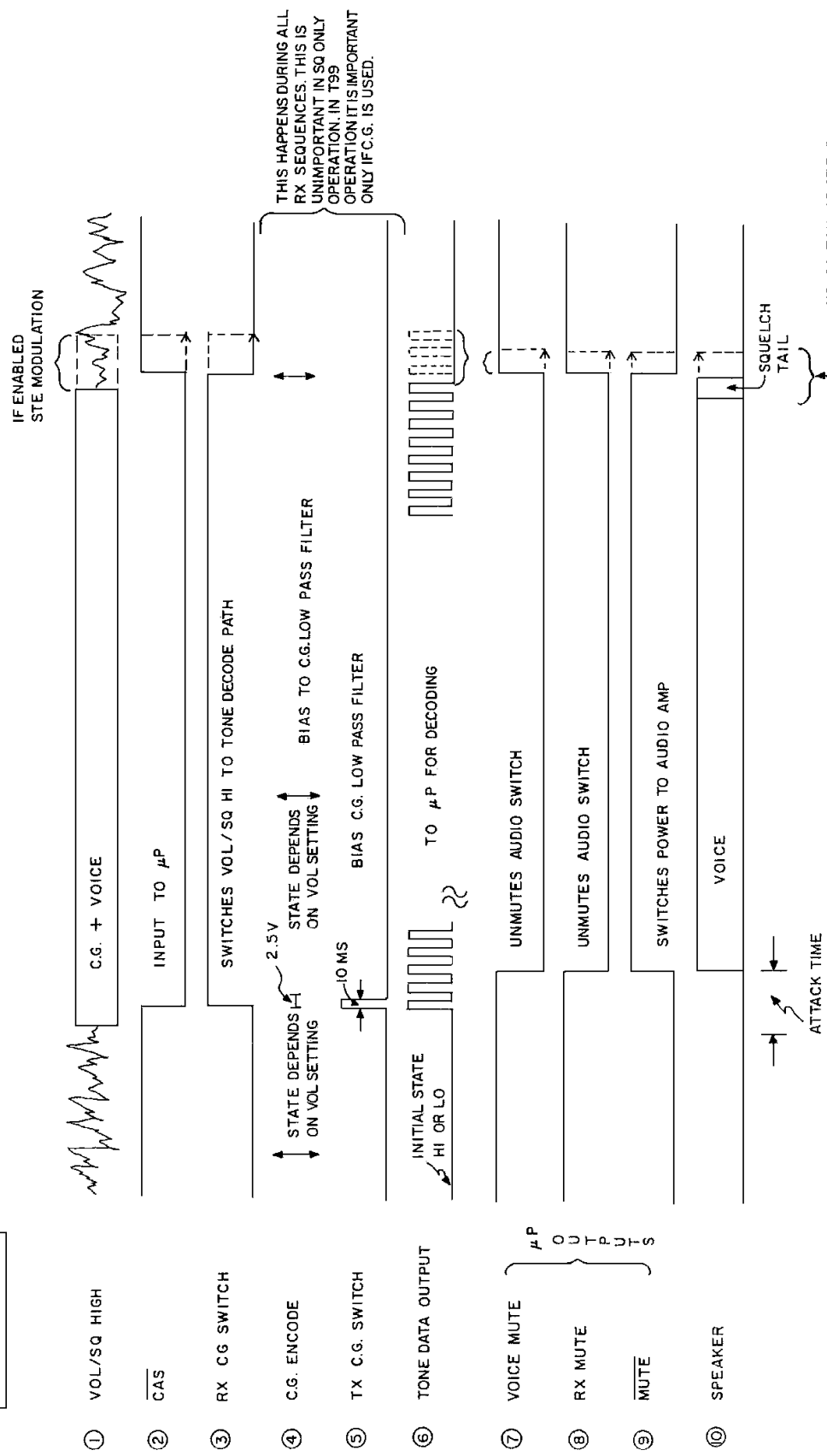

Figure 8 - RX Channel Guard Operation

④ RX - TYPE 99 OPERATION

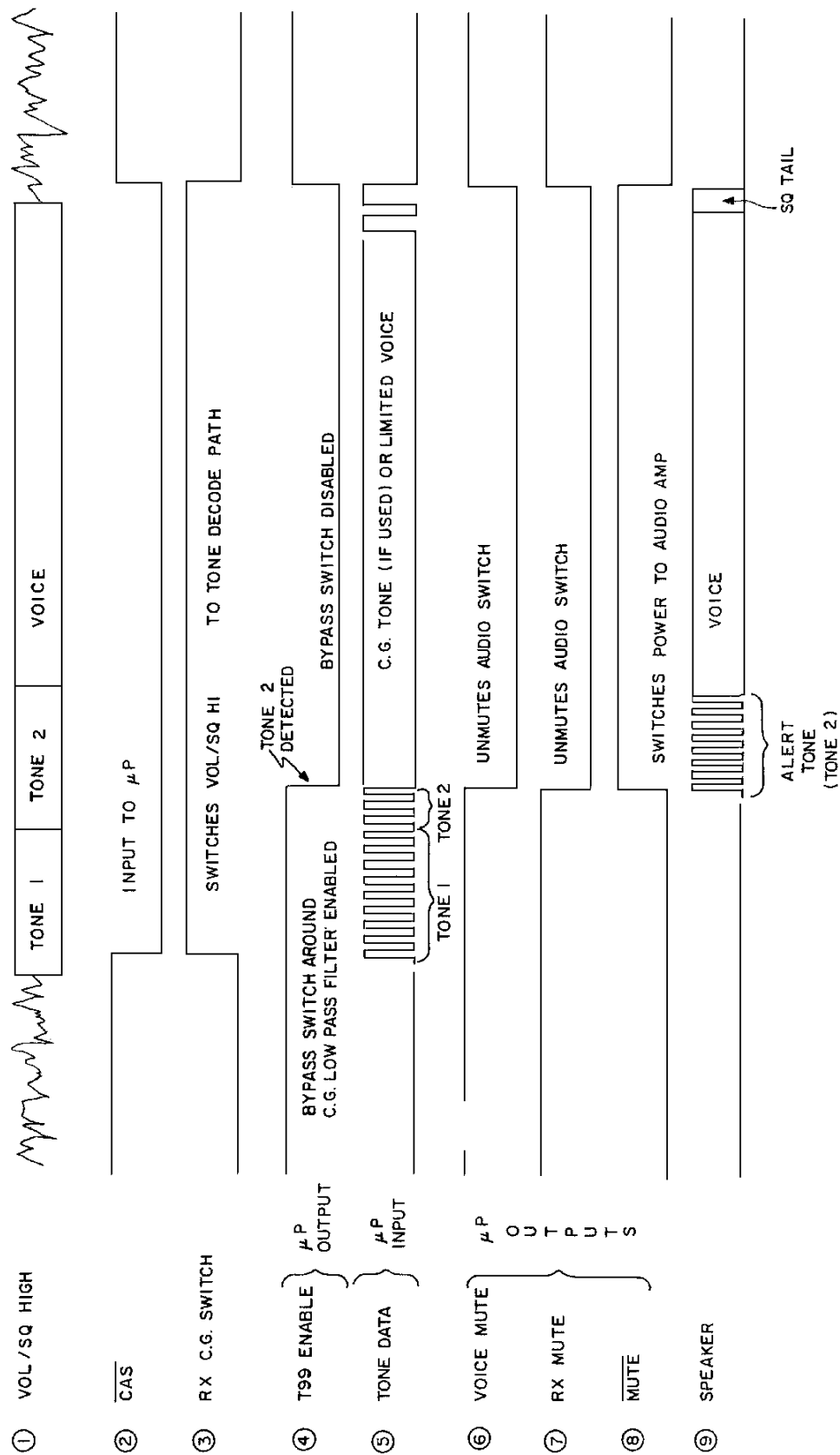

Figure 9 - RX Type 99 Operation

⑤ TX - VOICE ONLY

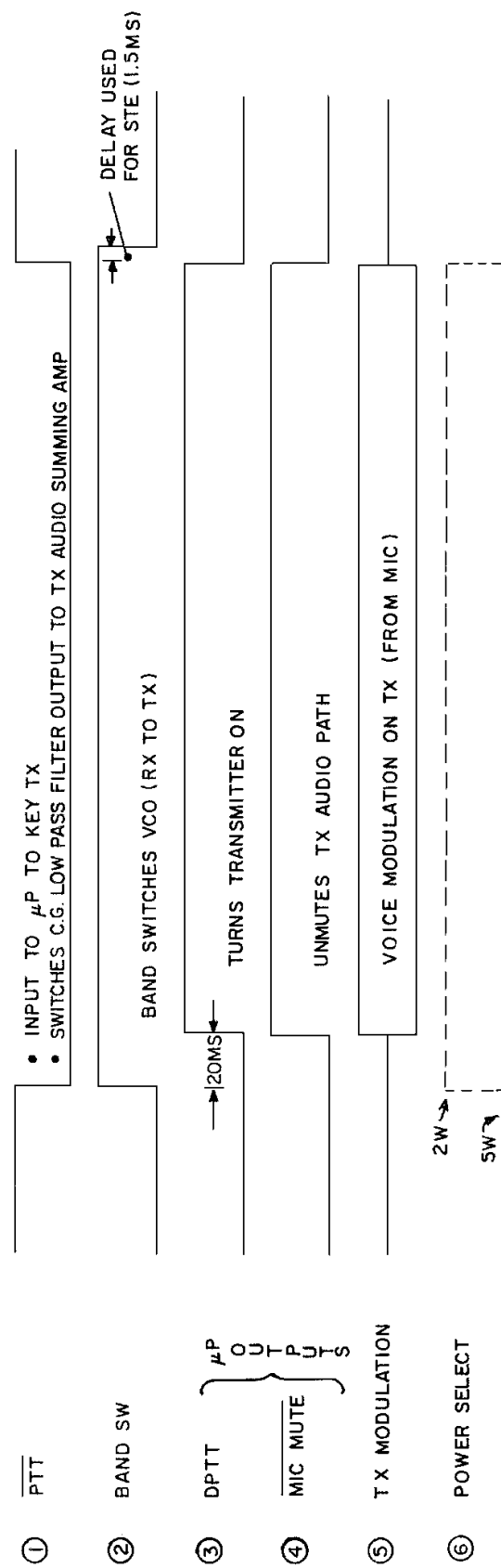

Figure 10 - TX Voice Only Operation

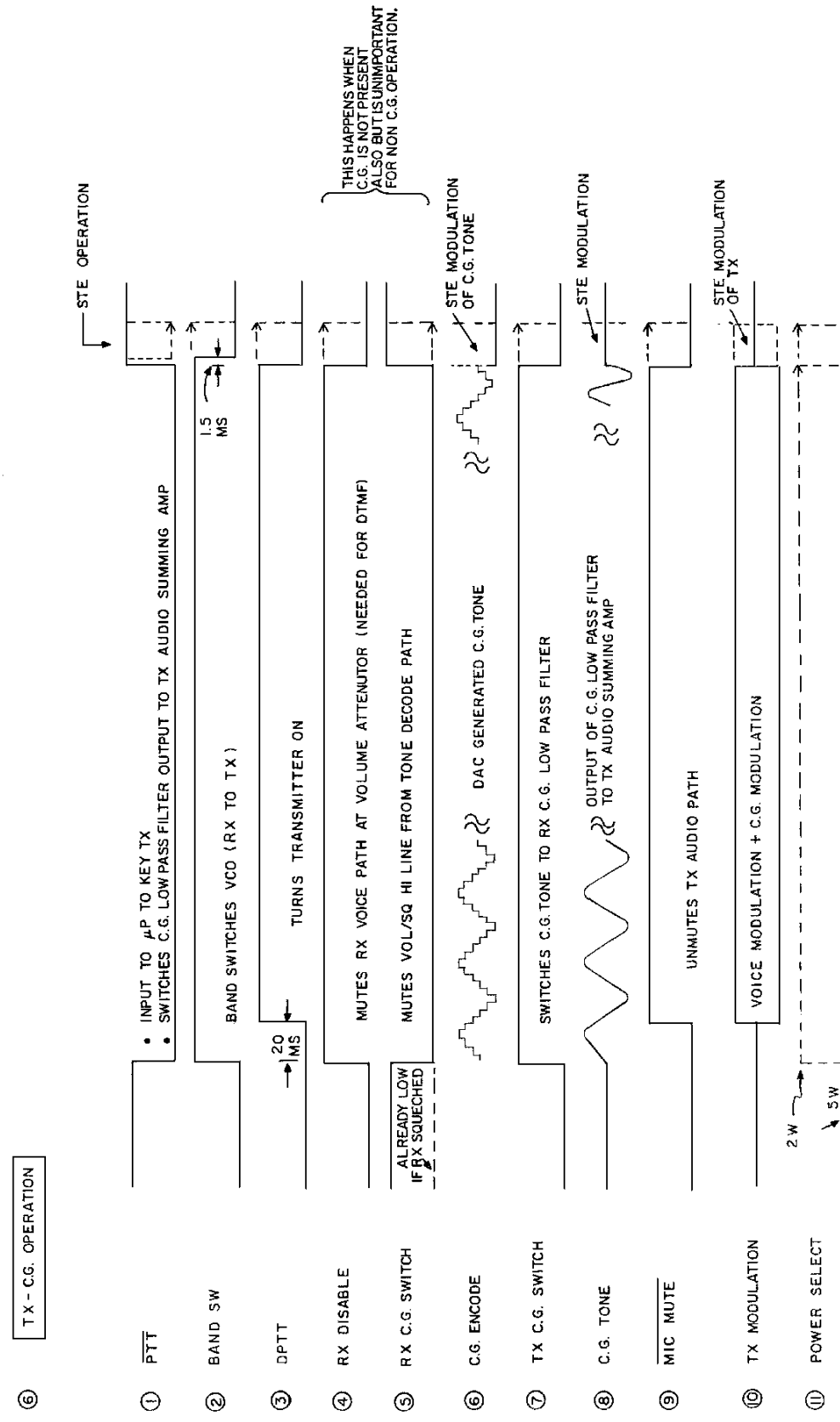

Figure 11 - TX Channel Guard Operation

**RADIO FRONT ASSEMBLY
19D902177G5 (2 Channels)
19D902177G6 (8 Channels)
Issue 3**

SYMBOL	PART NO.	DESCRIPTION
A2		AUDIO/LOGIC BOARD 19D902142G3 (Used in G5) 19D902142G4 (Used in G6)
A701		MICROPROCESSOR/SPUR FILTER BOARD 19C851678G1 (Used used in G3) 19C851678G2 (Used used in G4)
----- CAPACITORS -----		
C1 thru C34	19A702061P69	Ceramic: 220 pF ±5%, 50 VDCW, temp coef 0±30 PPM/°C.
C35	19A702052P14	Ceramic: 0.01 μF ±10%, 50 VDCW.
C36	19A702061P35	Ceramic: 30 pF ±5%, 50 VDCW, temp coef 0 ± 30 PPM.
----- PLUGS -----		
P701	19B801573P1	Connector.
----- RESISTORS -----		
R1	19B801251P102	Metal film: 1K ohms ±5%, 1/10 w.
R2 and R3	19B801251P101	Metal film: 100 ohms ±5%, 1/10 w.
R4 and R5	19B801251P102	Metal film: 1K ohms ±5%, 1/10 w.
R6	19B801251P101	Metal film: 100 ohms ±5%, 1/10 w.
R7 thru R14	19B801251P102	Metal film: 1K ohms ±5%, 1/10 w.
R15 thru R17	19B801251P101	Metal film: 100 ohms ±5%, 1/10 w.
R18 thru R22	19B801251P102	Metal film: 1K ohms ±5%, 1/10 w.
R23 thru R25	19B801251P471	Metal film: 470 ohms ±5%, 1/10 w.
R26 thru R30	19B801251P102	Metal film: 1K ohms ±5%, 1/10 w.
R31 thru R34	19B801251P101	Metal film: 100 ohms ±5%, 1/10 w.
R35	19B801251P220	Metal film: 22 ohms ±5%, 1/10 w.
----- INTEGRATED CIRCUITS -----		
U1	19A70557P8	Microcomputer; sim to INTEL N80C52. (Used in G1).
U1	19A70557P9	Microcomputer; sim to INTEL N80C52. (Used in G2).
----- CAPACITORS -----		
C301	19A702052P7	Ceramic: 2200 pF ±10%, 50 VDCW.
C302	19A702052P30	Ceramic: 0.022 μF ±10%, 50 VDCW.
C303	19A702061P61	Ceramic: 100 pF ±5%, 50 VDCW, temp coef 0 ± 30 PPM.
C304	19A702052P26	Ceramic: 0.1 μF ±10%, 50 VDCW.
C305	19A702052P110	Ceramic: 4700 pF ±5%, 50 VDCW.
C306	19A705205P2	Tantalum: 1 μF, 16 VDCW; sim to Sprague 293D.
C307	19A702052P107	Ceramic: 2200 pF ±5%, 50 VDCW.

*COMPONENTS ADDED, DELETED, OR CHANGED BY PRODUCTION CHANGES

SYMBOL	PART NO.	DESCRIPTION
C308	19A702052P30	Ceramic: 0.022 μF ±10%, 50 VDCW.
C309	19A702061P67	Ceramic: 180 pF ±5%, 50 VDCW, temp coef 0 ± 30 PPM.
C310	19A702052P26	Ceramic: 0.1 μF ±10%, 50 VDCW.
C311	19A702052P130	Ceramic: 0.022 μF ±5%, 50 VDCW.
C312 and C313	19A702052P26	Ceramic: 0.1 μF ±10%, 50 VDCW.
C314	19A702061P73	Ceramic: 330 pF ±5%, 50 VDCW, temp coef 0 ± 30 PPM/°C.
C315 and C316	19A702052P26	Ceramic: 0.1 μF ±10%, 50 VDCW.
C317	19A702052P30	Ceramic: 0.022 μF ±10%, 50 VDCW.
C318	19A702052P26	Ceramic: 0.1 μF ± 10%, 50 VDCW.
C319	19A702061P45	Ceramic: 47 pF ±5%, 50 VDCW, temp coef 0 + or -30 PPM.
C601	19A702052P107	Ceramic: 2200 pF ± 5%, 50 VDCW.
C602	19A702061P77	Ceramic: 470 pF ± 5%, 50 VDCW, temp coef 0 ± 30 PPM.
C603	19A702061P77	Ceramic: 470 pF ± 5%, 50 VDCW, temp coef 0 ± 30 PPM.
C604	19A702052P105	Ceramic: 1000 pF ± 5%, 50 VDCW.
C605	19A702052P7	Ceramic: 2200 pF ± 10%, 50 VDCW.
C606 and C607	19A702052P26	Ceramic: 0.1 μF ± 10%, 50 VDCW.
C608	19A702061P77	Ceramic: 470 pF ± 5%, 50 VDCW, temp coef 0 ± 30 PPM.
C609	19A702052P130	Ceramic: 0.022 μF ±5%, 50 VDCW.
C610	19A702052P110	Ceramic: 4700 pF ± 5%, 50 VDCW.
C611 and C612	19A702052P114	Ceramic: 0.01 μF ± 5%, 50 VDCW.
C613	19A702052P130	Ceramic: 0.022 μF ±5%, 50 VDCW.
C614	19A702052P26	Ceramic: 0.1 μF ±10%, 50 VDCW.
C615	19A702052P10	Ceramic: 4700 pF ±10%, 50 VDCW.
C616	19A702052P14	Ceramic: 0.01 μF ±10%, 50 VDCW.
C617	19A702052P5	Ceramic: 1000 pF ±10%, 50 VDCW.
C618	19A702052P5	Ceramic: 1000 pF ±10%, 50 VDCW.
C619	19A702052P14	Ceramic: 0.01 μF ±10%, 50 VDCW.
C620	19A704879P14	Electrolytic: 68 μF ±20%, 10 VDCW.
C621	19A702052P30	Ceramic: 0.022 μF ±10%, 50 VDCW.
C622	19A702052P30	Ceramic: 0.022 μF ±10%, 50 VDCW.
C623	19A704879P5	Electrolytic: 10 μF ±20%, 16 VDCW.
C624	19A702052P14	Ceramic: 0.01 μF ± 10%, 50 $\mu\text{AX}\Omega$.
C626 and C627	19A702052P26	Ceramic: 0.1 μF ±10%, 50 VDCW.
C628	19A705205P2	Tantalum: 1 μF, 16 VDCW; sim to Sprague 293D.
C629 and C630	19A702052P110	Ceramic: 4700 pF ±5%, 50 VDCW.
C631	19A702052P14	Ceramic: 0.01 μF ± 10%, 50 VDCW.
C632	19A702052P22	Ceramic: 0.047 μF ±10%, 50 VDCW.
C633	19A702052P7	Ceramic: 2200 pF ±10%, 50 VDCW.
C634	19A143565P12	Ceramic: 220000 pF ±10%, 50 VDCW; sim to C323C224K5R5CA.
C635	19A702061P69	Ceramic: 220 pF ±5%, 50 VDCW, temp coef 0±30 PPM/°C.
C636 thru C638	19A702061P69	Ceramic: 220 pF ±5%, 50 VDCW, temp coef 0±30 PPM/°C.
C639	19A702052P26	Ceramic: 0.1 μF ±10%, 50 VDCW.
C640	19A702052P110	Ceramic: 4700 pF ±5%, 50 VDCW.
C641	19A702052P112	Ceramic: 6800 pF ±5%, 50 VDCW.
C701	19A702061P37	Ceramic: 33 pF ±5%, 50 VDCW, temp coef 0 ± 30

SYMBOL	PART NO.	DESCRIPTION
C702	19A702052P30	Ceramic: 0.022 μF ±10%, 50 VDCW.
C703 and C704	19A702061P77	Ceramic: 470 pF ±5%, 50 VDCW, temp coef 0 ± 30 PPM.
C705	19A702061P69	Ceramic: 220 pF ±5%, 50 VDCW, temp coef 0 ± 30 PPM/°C.
C801	19A705205P2	Tantalum: 1 μF, 16 VDCW; sim to Sprague 293D.
C804	19A702052P14	Ceramic: 0.01 μF ± 10%, 50 VDCW.
C805	19A701534P9	Tantalum: 47 μF ±20%, 6.3 VDCW.
C806	19A704879P5	Electrolytic: 10 μF ±20%, 16 VDCW.
C807	19A705205P14	Tantalum: 6.8 μF, 6 VDCW; sim to Sprague 293D.
C808	19A702061P69	Ceramic: 220 pF ±5%, 50 VDCW, temp coef 0 ± 30 PPM/°C.
----- DIODES -----		
D601	19A705377P3	Silicon, Hot Carrier: sim to HSMS-2920.
D701 thru D704	19A700053P2	Silicon: 2 Diodes in Series; sim to BAV99.
D705 thru D707	19A700053P2	Silicon: 2 Diodes in Series; sim to BAV99.
D801	19A116585P1	Silicon, fast recovery, 600 mA, 50 PIV.
----- JACKS -----		
J701		Part of printed wire board.
J801	19A705482P1	Printed wire board connector.
J802	19B209648P1	Contact, electrical.
J901		Part of printed wire board.
----- TRANSISTORS -----		
Q601 and Q602	19A700076P2	Silicon, NPN: sim to MMBT3904, low profile.
Q603	19A700059P2	Silicon, PNP: sim to MMBT3906, low profile.
Q604	19A700076P2	Silicon, NPN: sim to MMBT3904, low profile.
Q605	19A700026P2	Silicon, PNP: sim to BC369.
Q606	19A700059P2	Silicon, PNP: sim to MMBT3906, low profile.
Q607	19A700059P2	Silicon, PNP: sim to MMBT3906, low profile.
Q608	19A700076P2	Silicon, NPN: sim to MMBT3904, low profile.
Q611	19A700076P2	Silicon, NPN: sim to MMBT3904, low profile.
Q612	19A700059P2	Silicon, PNP: sim to MMBT3906, low profile.
Q701	19A134739P2	Silicon, NPN.
Q702	19A700059P2	Silicon, PNP: sim to MMBT3906, low profile.
Q704	19A700076P2	Silicon, NPN: sim to MMBT3904, low profile.
Q706	19A700076P2	Silicon, NPN: sim to MMBT3904, low profile.
Q801	19A700059P2	Silicon, PNP: sim to MMBT3906, low profile.
Q802 and Q803	19A700076P2	Silicon, NPN: sim to MMBT3904, low profile.
----- RESISTORS -----		
R301	19B801251P104	Metal film: 100K ohms ±5%, 1/10 w.
R302	19B801251P105	Metal film: 1M ohms ±5%, 1/10 w.
R303	19B801251P272	Metal film: 2.7K ohms ±5%, 1/10 w.
R304	19B801251P103	Metal film: 10K ohms ±5%, 1/10 w.
R305	19B801251P102	Metal film: 1K ohms ±5%, 1/10 w.
R306	19B801251P103	Metal film: 10K ohms ±5%, 1/10 w.
R307	19B801251P333	Metal film: 33K ohms ±5%, 1/10 w.
R308	19B801251P104	Metal film: 100K ohms ±5%, 1/10 w.
R309	19B801251P224	Metal film: 220K ohms ±5%, 1/10 w.
R310 and R311	19B801251P153	Metal film: 15K ohms ±5%, 1/10 w.
R312 thru R314	19B801251P104	Metal film: 100K ohms ±5%, 1/10 w.
R315	19B801251P683	Metal film: 68K ohms ±5%, 1/10 w.

SYMBOL	PART NO.	DESCRIPTION
R316	19B801251P393	Metal film: 39K ohms ±5%, 1/10 w.
R317	19B801251P223	Metal film: 22K ohms ±5%, 1/10 w.
R318	19B801251P474	Metal film: 470K ohms ±5%, 1/10 w.
R319	19B801251P683	Metal film: 68K ohms ±5%, 1/10 w.
R320	19B801251P274	Metal film: 270K ohms ±5%, 1/10 w.
R321	19A705496P7	Variable, surface mount: 100K ohms ±25%, 1/10 w.
R322	19B801251P183	Metal film: 18K ohms ±5%, 1/10 w.
R324	19B801251P223	Metal film: 22K ohms ±5%, 1/10 w.
R325	19B801251P823	Metal film: 82K ohms ±5%, 1/10 w.
R326	19B801251P474	Metal film: 470K ohms ±5%, 1/10 w.
R327	19B801251P274	Metal film: 270K ohms ±5%, 1/10 w.
R329	19B801251P223	Metal film: 22K ohms ±5%, 1/10 w.
R330	19B801251P224	Metal film: 220K ohms ±5%, 1/10 w.
R601	19B801251P273	Metal film: 27K ohms ±5%, 1/10 w.
R602	19B801251P272	Metal film: 2.7K ohms ±5%, 1/10 w.
R603	19B801251P473	Metal film: 47K ohms ±5%, 1/10 w.
R604	19B801251P472	Metal film: 4.7K ohms ±5%, 1/10 w.
R605	19B801251P223	Metal film: 22K ohms ±5%, 1/10 w.
R606	19B801251P473	Metal film: 47K ohms ±5%, 1/10 w.
R607	19B801251P681	Metal film: 680 ohms ±5%, 1/10 w.
R608	19A705496P6	Variable resistor, surface mount: 50K ohms ± 25%, adjustment range 15 to 85%; sim to Murata Type RGV4E.
R609 and R610	19B801251P153	Metal film: 15K ohms ±5%, 1/10 w.
R611	19B801251P103	Metal film: 10K ohms ±5%, 1/10 w.
R612	19B801251P124	Metal film: 120K ohms ±5%, 1/10 w.
R613	19B801251P272	Metal film: 2.7K ohms ±5%, 1/10 w.
R614	19B801251P153	Metal film: 15K ohms ±5%, 1/10 w.
R615	19B801251P563	Metal film: 56K ohms ±5%, 1/10 w.
R616	19B801251P473	Metal film: 47K ohms ±5%, 1/10 w.
R617	19B801251P333	Metal film: 33K ohms ±5%, 1/10 w.
R618	19B801251P103	Metal film: 10K ohms ±5%, 1/10 w.
R619	19B801251P473	Metal film: 47K ohms ±5%, 1/10 w.
R620	19B801251P103	Metal film: 10K ohms ±5%, 1/10 w.
R621	19B801251P562	Metal film: 5.6K ohms ±5%, 1/10 w.
R622	19B801251P222	Metal film: 2.2K ohms ±5%, 1/10 w.
R623	19B801251P473	Metal film: 47K ohms ±5%, 1/10 w.
R624	19B801251P223	Metal film: 22K ohms ±5%, 1/10 w.
R625	19B801251P473	Metal film: 47K ohms ±5%, 1/10 w.
R626	19B801251P471	Metal film: 470 ohms ±5%, 1/10 w.
R627	19B801251P472	Metal film: 4.7K ohms ±5%, 1/10 w.
R628	19B801251P823	Metal film: 82K ohms ±5%, 1/10 w.
R629	19B801251P103	Metal film: 10K ohms ±5%, 1/10 w.
R630	19B801251P472	Metal film: 4.7K ohms ±5%, 1/10 w.
R631	19B801251P824	Metal film: 820K ohms ±5%, 1/10 w.
R632	19B801251P154	Metal film: 150K ohms ±5%, 1/10 w.
R633	19B801251P821	Metal film: 820 ohms ±5%, 1/10 w.
R634	19B801251P272	Metal film: 2.7K ohms ±5%, 1/10 w.
R635	19B801251P822	Metal film: 8.2K ohms ±5%, 1/10 w.
R636	19B801251P223	Metal film: 22K ohms ±5%, 1/10 w.
R637	19B801251P473	Metal film: 47K ohms ±5%, 1/10 w.
R638	19B801251P823	Metal film: 82K ohms ±5%, 1/10 w.
R639	19B801251P154	Metal film: 150K ohms ±5%, 1/10 w.
R640	19B801251P274	Metal film: 270K ohms ±5%, 1/10 w.
R641	19B801251P473	Metal film: 47K ohms ±5%, 1/10 w.
R642	19B801251P102	Metal film: 1K ohms ±5%, 1/10 w.
R643	19B801251P104	Metal film: 100K ohms ±5%, 1/10 w.
R644	19B801251P123	Metal film: 12K ohms ±5%, 1/10 w.
R645	19B801251P103	Metal film: 10K ohms ±5%, 1/10 w.
R646 thru R649	19B801251P100	Metal film: 10 ohms ±5%, 1/10 w.

SYMBOL	PART NO.	DESCRIPTION
R650	19B801251P154	Metal film: 150K ohms ±5%, 1/10 w.
R651	19B801251P104	Metal film: 100K ohms ±5%, 1/10 w.
R652 and R653	19B801251P224	Metal film: 220K ohms ±5%, 1/10 w.
R654	19B801251P682	Metal film: 6.8K ohms ±5%, 1/10 w.
R655 and R656	19B801251P474	Metal film: 470K ohms ±5%, 1/10 w.
R657	19B801251P473	Metal film: 47K ohms ±5%, 1/10 w.
R658	19B801251P333	Metal film: 33K ohms ±5%, 1/10 w.
R659	19B801251P473	Metal film: 47K ohms ±5%, 1/10 w.
R660	19B801251P473	Metal film: 47K ohms ±5%, 1/10 w.
R661	19B801251P104	Metal film: 100K ohms ±5%, 1/10 w.
R662 and R663	19B801251P223	Metal film: 22K ohms ±5%, 1/10 w.
R664	19A705813P1	Thermistor: sim to AL03006-624-73-G100.
R668 and R669	19B801251P333	Metal film: 33K ohms ±5%, 1/10 w.
R670	19B801251P563	Metal film: 56K ohms ±5%, 1/10 w.
R671	19B801251P222	Metal film: 2.2K ohms ±5%, 1/10 w.
R672	19B801251P561	Metal film: 560 ohms ±5%, 1/10 w.
R673	19B801251P334	Metal film: 330K ohms ±5%, 1/10 w.
R674	19B801251P684	Metal film: 680K ohms ±5%, 1/10 w.
R675	19B801251P474	Metal film: 470K ohms ±5%, 1/10 w.
R676	19B801251P394	Metal film: 390K ohms ±5%, 1/10 w.
R677	19B801251P334	Metal film: 330K ohms ±5%, 1/10 w.
R679	19B801251P104	Metal film: 100K ohms ±5%, 1/10 w.
R701 thru R704	19B801251P473	Metal film: 47K ohms ±5%, 1/10 w.
R705	19B801251P103	Metal film: 10K ohms ±5%, 1/10 w.
R706	19B801251P473	Metal film: 47K ohms ±5%, 1/10 w.
R707	19B801251P334	Metal film: 330K ohms ±5%, 1/10 w.
R708 and R709	19B801251P473	Metal film: 47K ohms ±5%, 1/10 w.
R710	19B801251P224	Metal film: 220K ohms ±5%, 1/10 w.
R711	19B801251P334	Metal film: 330K ohms ±5%, 1/10 w.
R712	19B801251P103	Metal film: 10K ohms ±5%, 1/10 w.
R715 thru R720	19B801251P473	Metal film: 47K ohms ±5%, 1/10 w.
R721	19B801251P103	Metal film: 10K ohms ±5%, 1/10 w.
R722	19B801251P223	Metal film: 22K ohms ±5%, 1/10 w.
R723 thru R725	19B801251P473	Metal film: 47K ohms ±5%, 1/10 w.
R726	19B801251P824	Metal film: 820K ohms ±5%, 1/10 w.
R727	19B801251P394	Metal film: 390K ohms ±5%, 1/10 w.
R728	19B801251P224	Metal film: 220K ohms ±5%, 1/10 w.
R729	19B801251P104	Metal film: 100K ohms ±5%, 1/10 w.
R730	19A702931P234	Metal film: 2210 ohms ±1%, 200 VDCW, 1/8 w.
R731	19B801251P473	Metal film: 47K ohms ±5%, 1/10 w.
R732	19B801251P333	Metal film: 33K ohms ±5%, 1/10 w.
R801	19B801251P223	Metal film: 22K ohms ±5%, 1/10 w.
R802	19B801251P183	Metal film: 18K ohms ±5%, 1/10 w.
R803	19B801251P222	Metal film: 2.2K ohms ±5%, 1/10 w.
R804 and R805	19B801251P223	Metal film: 22K ohms ±5%, 1/10 w.
R806	19B801251P473	Metal film: 47K ohms ±5%, 1/10 w.
R807	19B801251P472	Metal film: 4.7K ohms ±5%, 1/10 w.

SYMBOL	PART NO.	DESCRIPTION
R808	19B801251P104	Metal film: 100K ohms ±5%, 1/10 w.
R809	19B801251P333	Metal film: 33K ohms ±5%, 1/10 w.
R810	19B801251P473	Metal film: 47K ohms ±5%, 1/10 w.
R811	19B801251P103	Metal film: 10K ohms ±5%, 1/10 w.
U301	19A705450P2	Dual Operational Amplifier, sim to MC34072.
U302 and U303	19A702293P3	Linear: Dual Op Amp; sim to LM358D.
U601	19A702293P1	Linear: Quad Op Amp; sim to LM324D.
U602	19A702293P3	Linear: Dual Op Amp; sim to LM358D.
U603	19A702705P3	Digital: 8-Channel Analog Multiplexer; sim to 4051BM.
U604	19A705452P1	Linear: Audio Amplifier; sim to TDA 2822M.
U605	19A702705P4	Digital: Quad Analog Switch/Multiplexer; sim to 4066BM.
U606	19A702293P3	Linear: Dual Op Amp; sim to LM358D.
U701	19A704724P3	Digital, EEPROM:
U801	19A705454P1	Voltage Detector, sim to Seiko S 8054ALO.
U802	19A702536P1	Linear positive voltage regulator; sim to LM2931AZ-5.
Y701	19A702511G26	Quartz: 11.0592 MHz.
A5	19A702364P310 19B801570P2 19A705662P1 19A702364P304	MISCELLANEOUS Machine screw, TORX Drive: No. M3-0.5 x 10. Holder, connector. Connector, Elastomeric. Machine screw, TORX drive, Pan Head.
H1	19C851660P1	Crystal Display.
D1 thru D4	19A703685P3 19B801569P1 19C851719P2	MISCELLANEOUS LCD Connector. Diffuser. Lens.
P1	19B801235P13	Terminal strip.
P2	19B801235P3	Terminal strip.
Q1	19A700059P2	Silicon, PNP: sim to MMBT3906, low profile.
Q2	19A700076P2	Silicon, NPN: sim to MMBT3904, low profile.

SYMBOL	PART NO.	DESCRIPTION
R1	19B801251P105	Metal film: 1M ohms ±5%, 1/10 w.
R2	19B801251P221	Metal film: 220 ohms ±5%, 1/10 w.
R3 and R4	19B801251P124	Metal film: 120K ohms ±5%, 1/10 w.
R5 and R6	19B801251P472	Metal film: 4.7K ohms ±5%, 1/10 w.
R7	19B801251P221	Metal film: 220 ohms ±5%, 1/10 w.
U1	19A705714P1	LCD Driver.
A6	19A705496P6	CONTROL ASSEMBLY 19A705090G8
C3 thru C7	19A702052P3	Ceramic: 470 pF ±10%, 50 VDCW.
J1	19A115834P1	Contact, electrical: sim to AMP 2-330808-8.
M1	19A701301P3	Cartridge: Electret.
S1	19A705712P1	Switch, subminiature.
S2	19A705712P2	Switch, subminiature.
B902	19A149673P1	Round: Water Proof, 24 ohms, 1/2 w.; sim to Line Electric Co. VS-50W24.
	19A705733P3 19B801571P3 19C851722P1	MISCELLANEOUS Control frame, circuitized. Dome switch. Boot, auxiliary jack.
	19A149926P2 19A702364P304 19C851997P1 19C851636P1 19A149926P4 19D902180G5 19D901978P1 19A116318P4 19A705664P1	MODULE Insulator. Machine screw, TORX drive, Pan Head. Gasket, Speaker. Switch pad. Insulator. Cap Assembly. Includes: Front cover. Foil, Magnetic Shielding: 1.50 inches wide. Gasket.

PRODUCTION CHANGES

Changes in the equipment to improve performance or to simplify circuits are identified by a "Revision Letter", which is stamped after the model number of the unit. The revision stamped on the unit includes all previous revisions. Refer to the Parts List for the descriptions of parts affected by these revisions.

REV. A - AUDIO/LOGIC BOARD 19D902142G3 & G4
To improve data integrity in the personality PROM due to power switching on/off added C807, deleted Q705, R713, and R714, and changed U701. Old part numbers were:
Q705 - 19A700059P2, Silicon, PNP.
R713 - 19B801251P223, Metal film: 22K ohm ±5%, 1/10 w.
R714 - 19B801251P222, Metal film: 2.2K ohm ±5%, 1/10 w.
U701 - 19A704724P1, EEPROM, 512 x 8 serial; sim to Xicor X2404.

REV. B - AUDIO/LOGIC BOARD 19D902142G3 & G4
No Changes.

REV. C - AUDIO/LOGIC BOARD 19D902142G3 & G4
To incorporate the use of a new VCO module changed R321. Old part number was:
R321 - 19A705496P6, Variable: 50k ohms.

REV. A - MICROPROCESSOR/SPUR FILTER BOARD 19C851678G1 & G2
To add Channel Guard disable capability and update digital Channel Guard squelch tail elimination software changed U1. Old part numbers were:
U1 - 19A704345P2, Microcomputer: CHMOS, 8 bit; sim to N80C51BH. (Used in G1).
U1 - 19A704345P3, Microcomputer: CHMOS, 8 bit; sim to N80C51BH. (Used in G2).

REV. B - MICROPROCESSOR/SPUR FILTER BOARD 19C851678G1 & G2
To make more parts common between the different groups changed R2 and R3 in G1, and added R2 and R3 to G2. Old part numbers were:
R2 - 19B801251P102, Metal film: 1K ohm ±5%, 1/10 w.
R3 - 19B801251P102, Metal film: 1K ohm ±5%, 1/10 w.

REV. C - MICROPROCESSOR/SPUR FILTER BOARD 19C851678G1 & G2
To incorporate the use of a new VCO module changed R15. Old part number was:
R15 - 19B801251P102, Metal film; 1K ohm ±5%, 1/10 w. -

REV. D - AUDIO/LOGIC BOARD 19D902142G3 & G4
To improve voice blocking and to facilitate manufacturing, the following changes were added: C317-C319, C639-C641, C808, D601, Q611, Q612, R327, R329, R330, R668-R677, R679 & R811. The following components were changed:
C305 was 19A702052P14 - Ceramic: 0.01 µF ±10%, 50 VDCW.
C608 was 19A702052P30 - Ceramic: 0.022 µF ±10%, 50 VDCW.
C610 was 19A702052P10 - Ceramic: 4700 µF ±10%, 50 VDCW.
C629 was 19A702052P20 - Ceramic: .033 µF ±10%, 50 VDCW.
C630 was 19A702052P3 - Ceramic: 470 µF ±10%, 50 VDCW.
C634 was 19A704879P12 - Electrolytic: .22 µF ±20%, 50 VDCW.
R307 was 19B801251P103 - Metal film: 10K ohms ±5%, 1/10 w.
R308 was 19B801251P334 - Metal film: 330K ohms ±5%, 1/10 w.
R309 was 19B801251P334 - Metal film: 330K ohms ±5%, 1/10 w.
R316 was 19B801251P154 - Metal film: 150K ohms ±5%, 1/10 w.
R317 was 19B801251P154 - Metal film: 150K ohms ±5%, 1/10 w.
R615 was 19B801251P224 - Metal film: 220K ohms ±5%, 1/10 w.
R650 was 19B801251P124 - Metal film: 120K ohms ±5%, 1/10 w.
R651 was 19B801251P334 - Metal film: 330K ohms ±5%, 1/10 w.
R652 was 19B801251P104 - Metal film: 100K ohms ±5%, 1/10 w.
R654 was 19B801251P393 - Metal film: 39K ohms ±5%, 1/10 w.
U301 was 19A705450P3 - Operational Amplifier, sim to MC34071.

REV. E - AUDIO/LOGIC BOARD 19D902142G3 & G4
REV. D - MICROPROCESSOR BOARD/SPUR FILTER BOARD 19C851678G1 & G2
To incorporate new features and improve CG Decode time, the following changes were made:
On the Spur Filter Board 19C851678G1 & G2, U1 was changed:
U1 was 19A704345P4 - Microcomputer: CHMOS, 8-bit; sim to N80C51BH. (In Group 1).
U1 was 19A704345P5 - Microcomputer: CHMOS, 8-bit; sim to N80C51BH. (In Group 2).
On the Audio/Logic Board 19D902142G3 & G4, Y701 was changed:
Y701 was 19A702511G30 - Crystal, quartz: 8.192 MHz.

FRONT ASSEMBLY

LCD DRIVER U1
19A705714P1

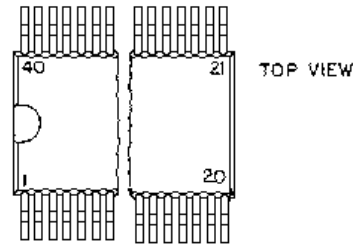

- PINNING**
- SUPPLY**
- 2 V_{DD} POSITIVE SUPPLY
 - 4 V_{SS} NEGATIVE SUPPLY
- INPUTS**
- 3 OSC OSCILLATOR INPUT
 - 39 DATA DATA LINE
 - 40 DLEN DATA LINE ENABLE } CBUS
 - 1 CLB CLOCK BURST
- OUTPUTS**
- 38 8P BACK PLANE DRIVER (COMMON OF LCD)
 - 5 TO 36 LCD DRIVER OUTPUTS (S32 TO S1)
 - 37 N.C. NOT CONNECTED

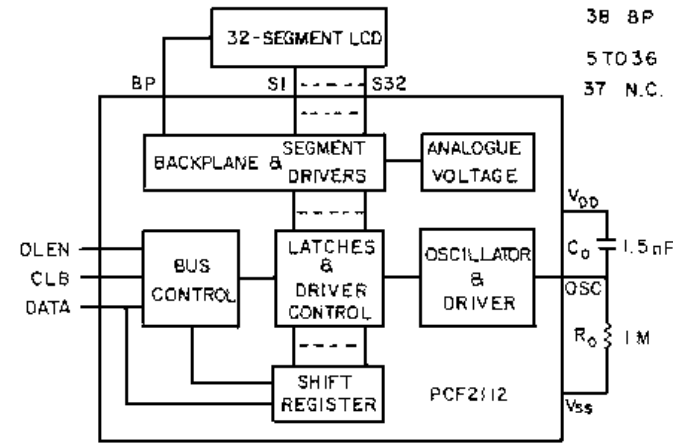

BLOCK DIAGRAM

LCD
19C851660P1

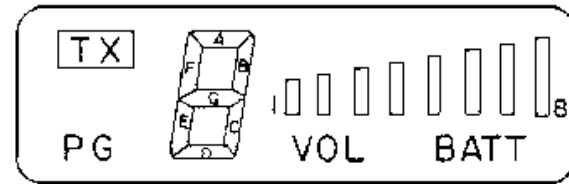

PIN OUT	
1	COM
2	PG
3	1E
4	1D
5	1C
6	BAR 1
7	BAR 2
8	VOL
9	BAR 5
10	BAT
11	—
12	COM
13	—
14	BAR 8
15	BAR 7
16	BAR 6
17	BAR 4
18	BAR 3
19	1B
20	1A
21	1F
22	1G
23	TX
24	COM

OPERATIONAL AMPLIFIER
U302/U703/U602
19A702293P2

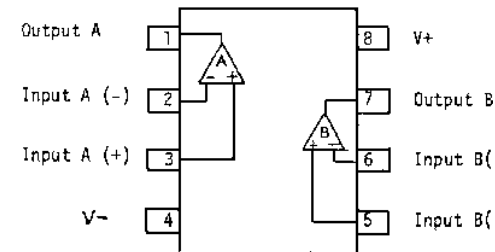
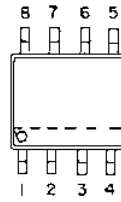

OPERATIONAL AMPLIFIER U301
19A705450P3

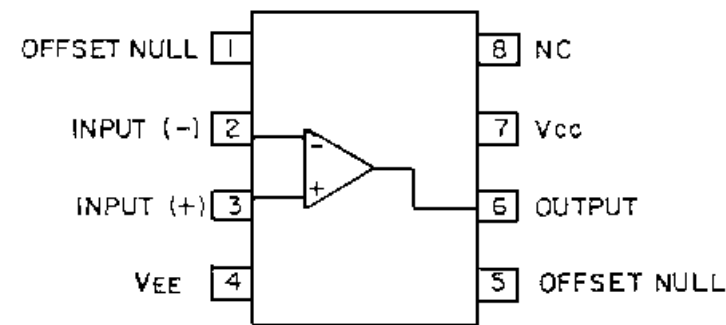
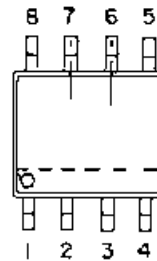

AUDIO AMPLIFIER U604
19A705452P1

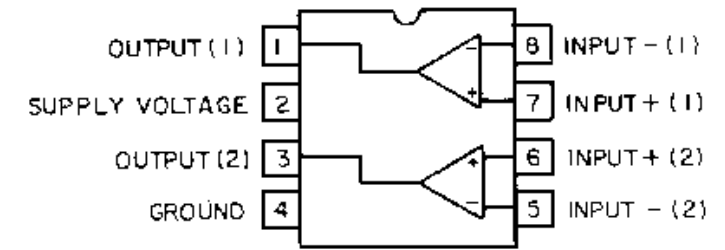
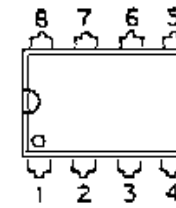

(TOP VIEW)

OPERATIONAL AMPLIFIER U601
19A702293P1

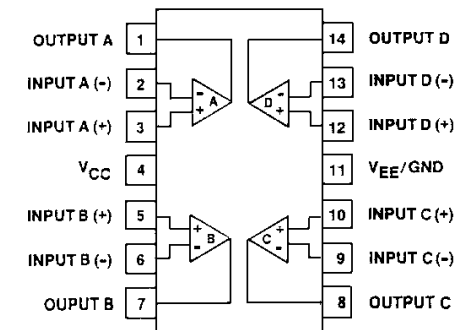
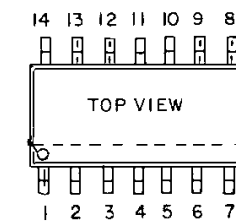

PIN 1 MAY BE IDENTIFIED BY INDENT OR CHAMFER

**BILATERAL SWITCH U603
19A702705P3**

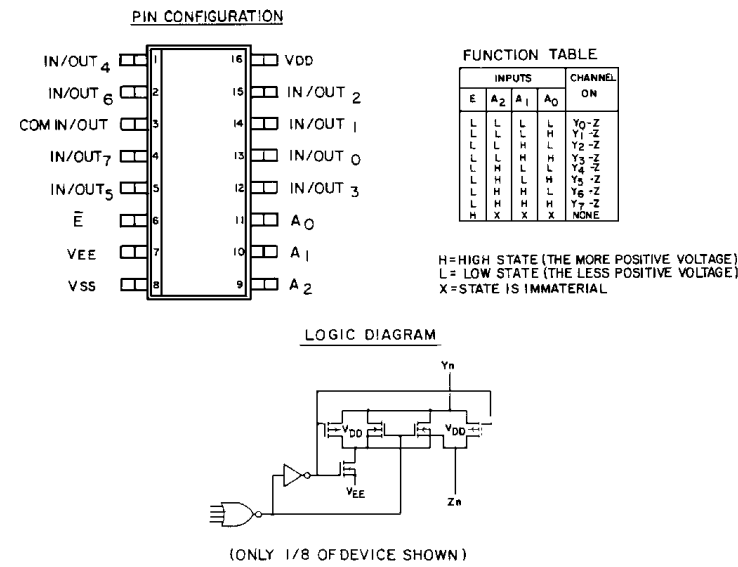

**EPROM U701
19A70474P1**

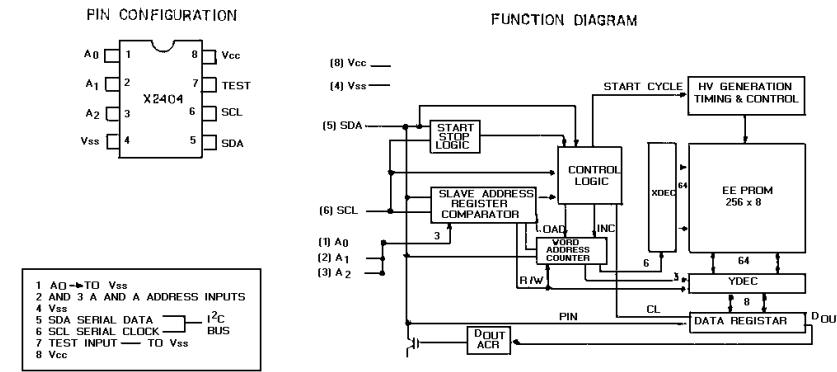

**BILATERAL SWITCH U605
19A702705P1**

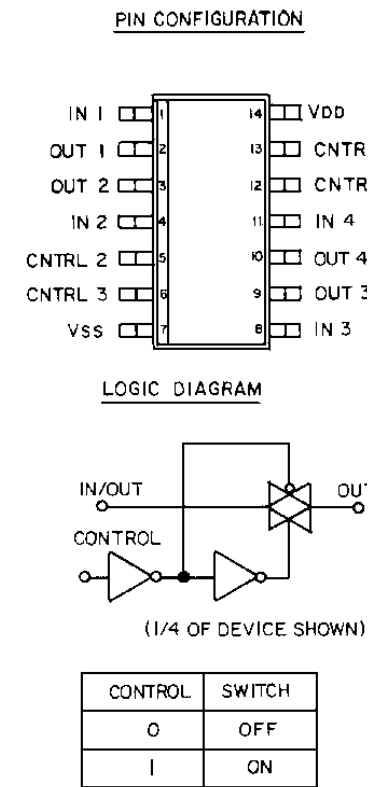

**VOLTAGE, DETECTOR U801
19A705454P1**

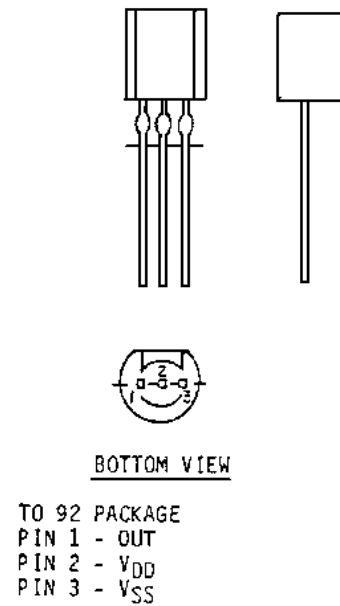

**VOLTAGE REGULATOR U802
19A702536P1**

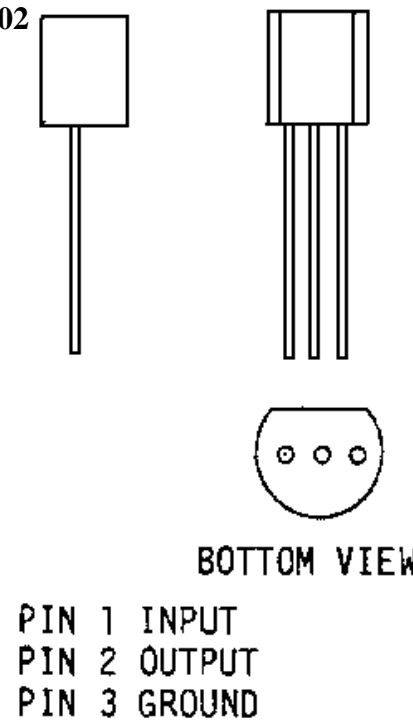

**MICROPROCESSOR U1 (80C51)
19A704345P2 & P3**

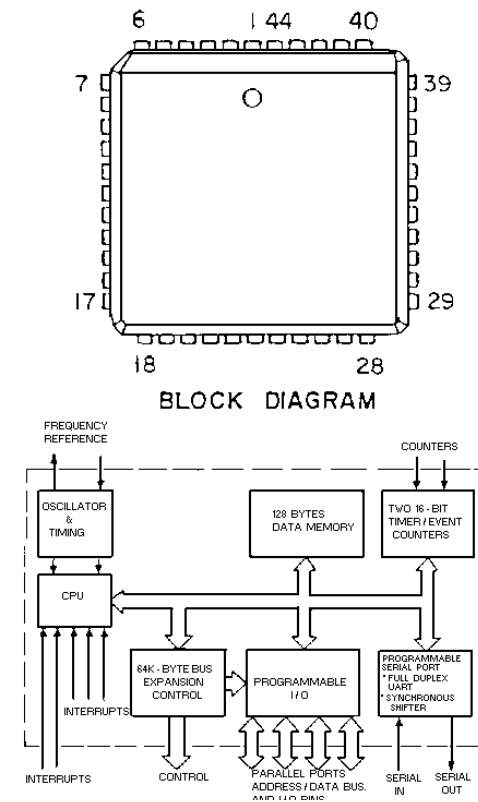

FRONT ASSEMBLY

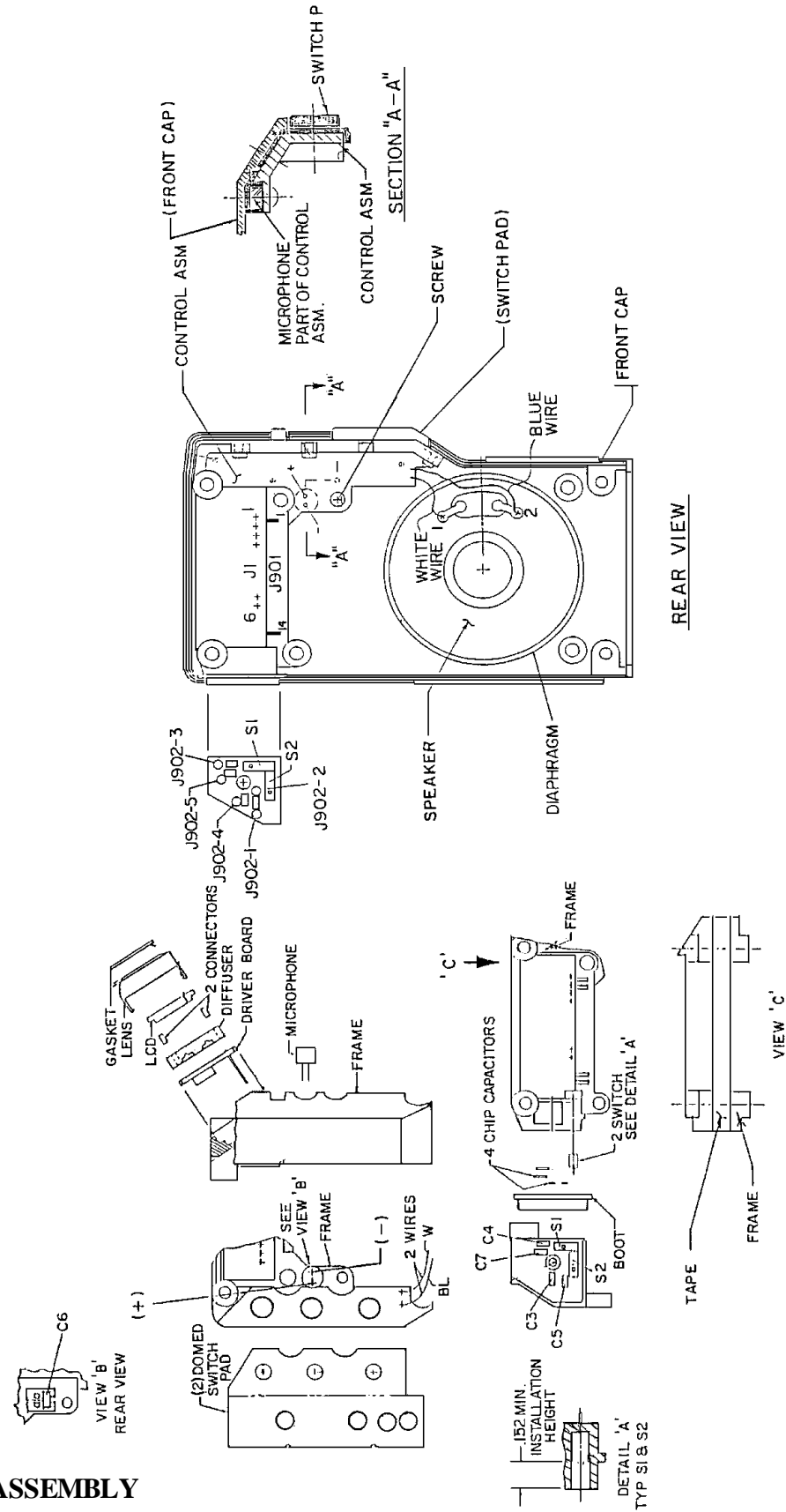

FRONT CAP ASSEMBLY
19D902180G1

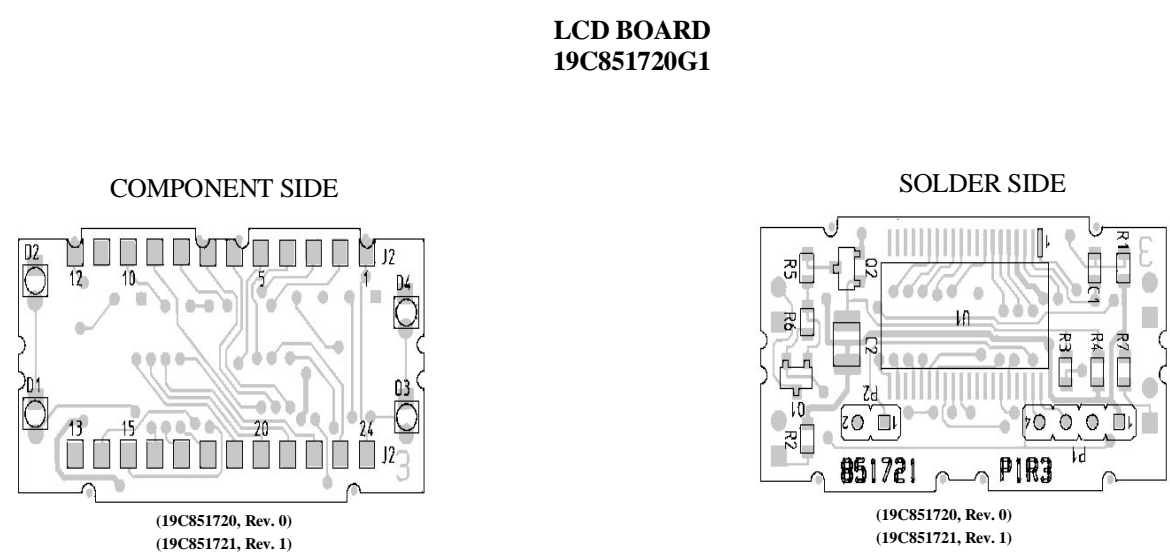

LCD BOARD
19C851720G1

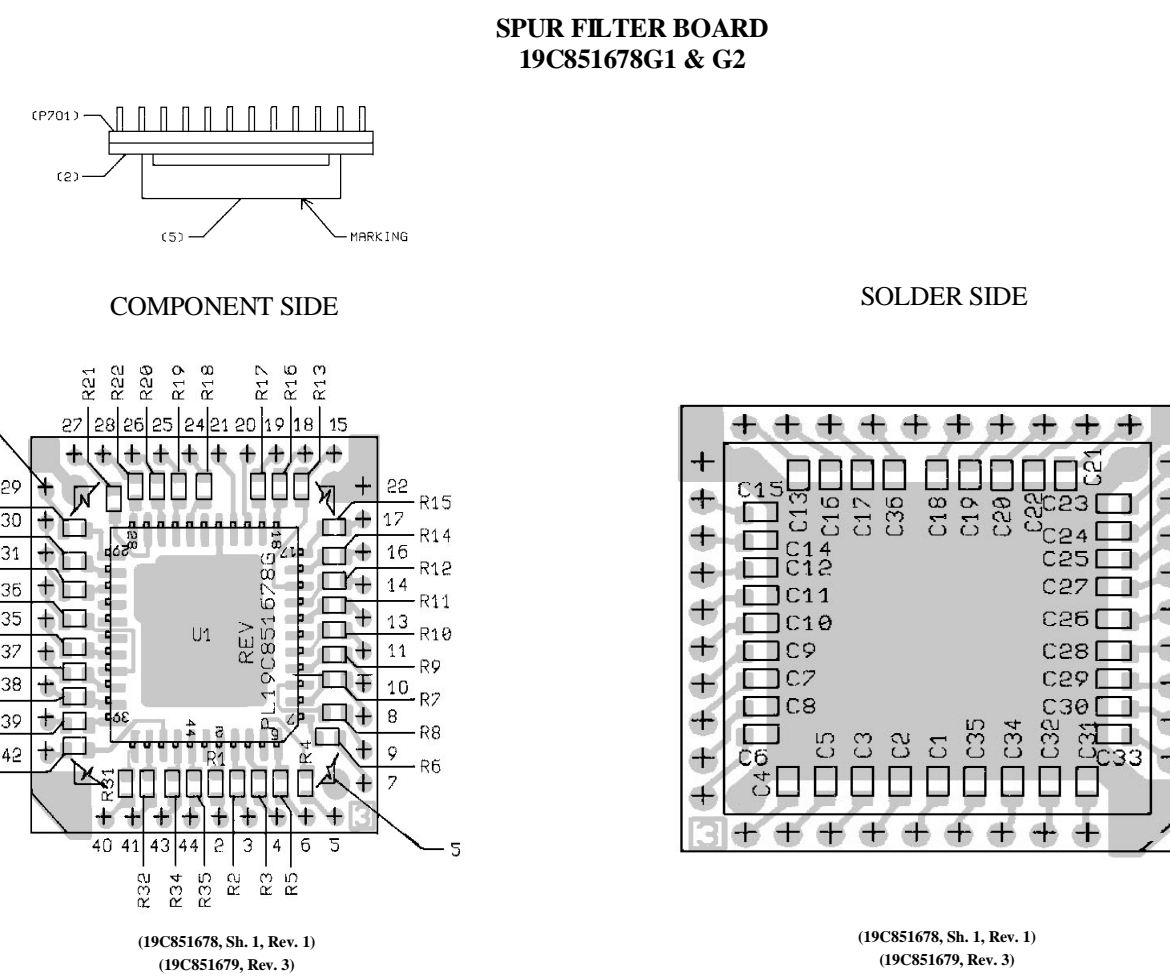

SPUR FILTER BOARD
19C851678G1 & G2

COMPONENT SIDE

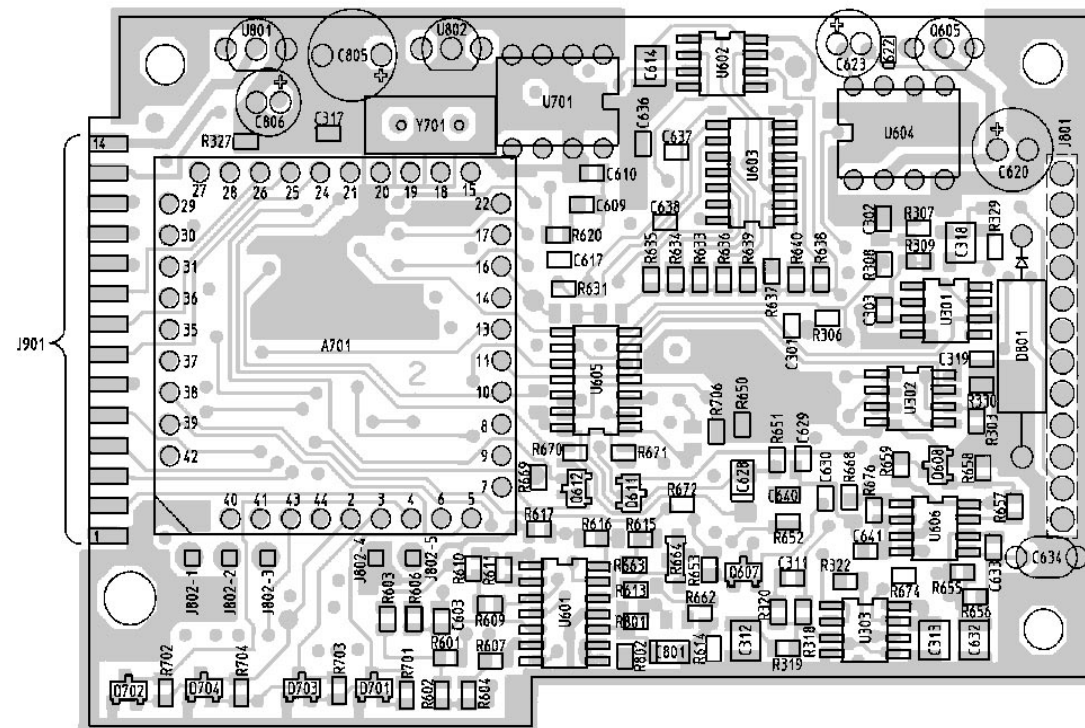

(19D902142, Sh. 2, Rev. 2)
(19D902141, First Layer, Rev. 2)

SOLDER SIDE

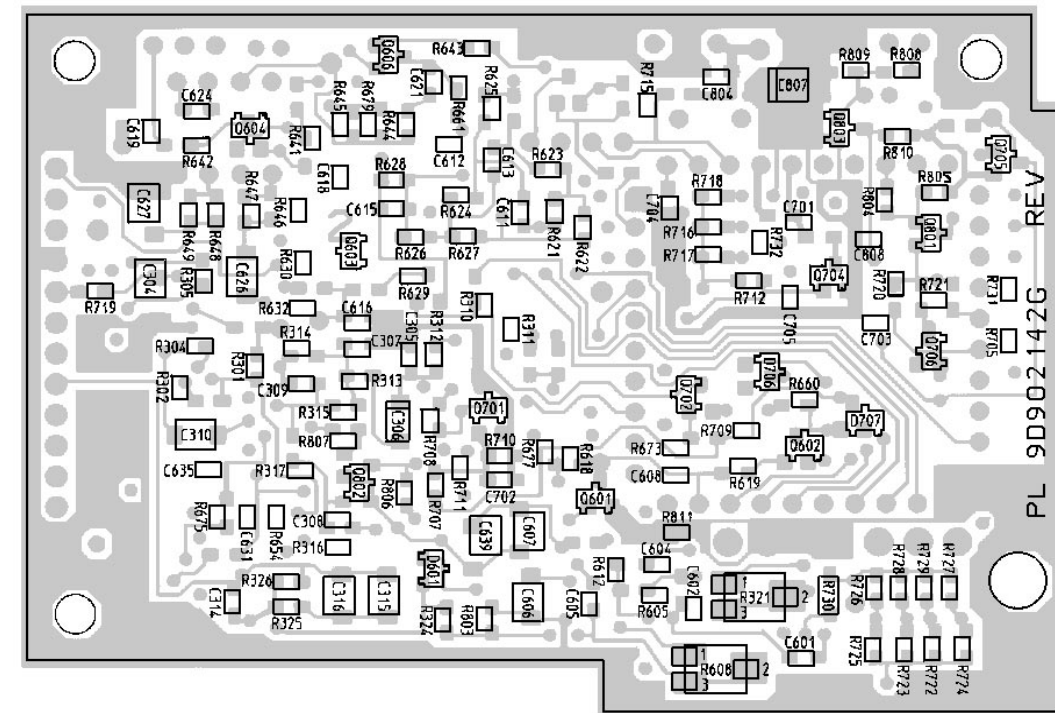

(19D902142, Sh. 2, Rev. 4)
(19D902141, Fourth Layer, Rev. 2)

FRONT ASSEMBLY

LEAD IDENTIFICATION FOR
D601 & D701-D707
(SOT) DIODES
(TOP VIEW)

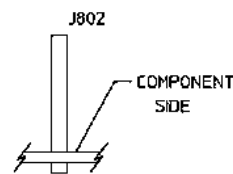
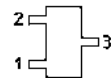

LEAD IDENTIFICATION
FOR U801
FLAT
IN-LINE
TOP VIEW

NOTE: CASE SHAPE IS DETERMINING
FACTOR FOR LEAD IDENTIFICATION

LEAD IDENTIFICATION FOR
Q601-Q608, Q701, Q702, Q704-Q706
Q801-Q803
(SOT) TRANSISTORS
(TOP VIEW)

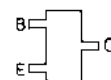

LEAD IDENTIFICATION
FOR Q605
FLAT
IN-LINE
TOP VIEW

NOTE: CASE SHAPE IS DETERMINING
FACTOR FOR LEAD IDENTIFICATION

LEAD IDENTIFICATION
FOR U802
FLAT
IN-LINE
TOP VIEW

NOTE: CASE SHAPE IS DETERMINING
FACTOR FOR LEAD IDENTIFICATION

AUDIO/LOGIC BOARD
19D902142G3, G4

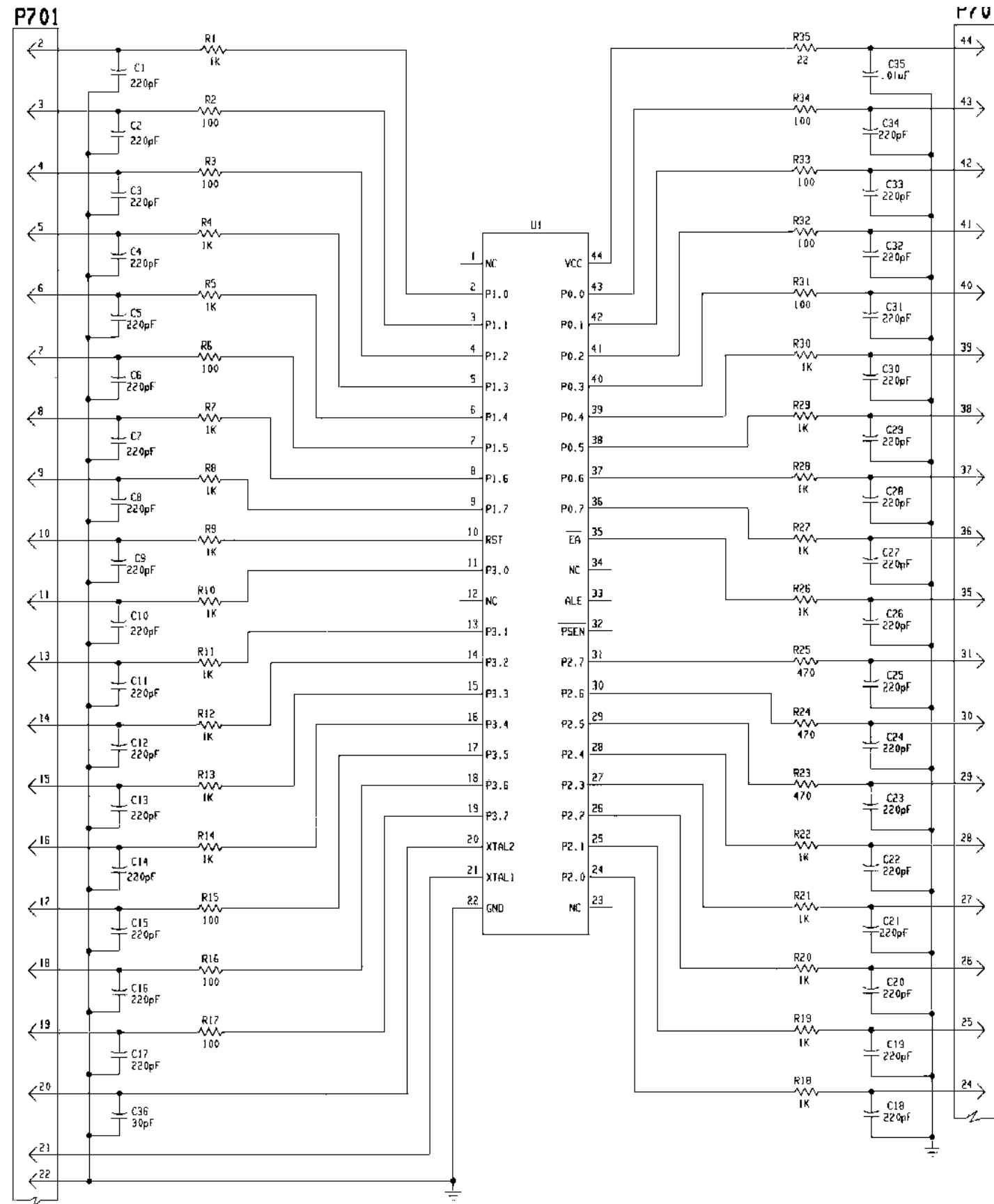

ALL RESISTORS ARE 0.1 WATT UNLESS OTHERWISE SPECIFIED AND RESISTOR VALUES ARE IN OHMS UNLESS FOLLOWED BY MULTIPLIER K OR M. CAPACITOR VALUES IN P UNLESS FOLLOWED BY MULTIPLIER U, N OR P. INDUCTANCE VALUES IN H UNLESS FOLLOWED BY MULTIPLIER H OR U.

THIS SCHEMATIC DIAGRAM APPLIES TO	
MODEL NO.	REV LETTER
19C851678G1	C
19C851678G2	C
19C851678G3	B

SPUR FILTER BOARD
19C851678G1 & G2

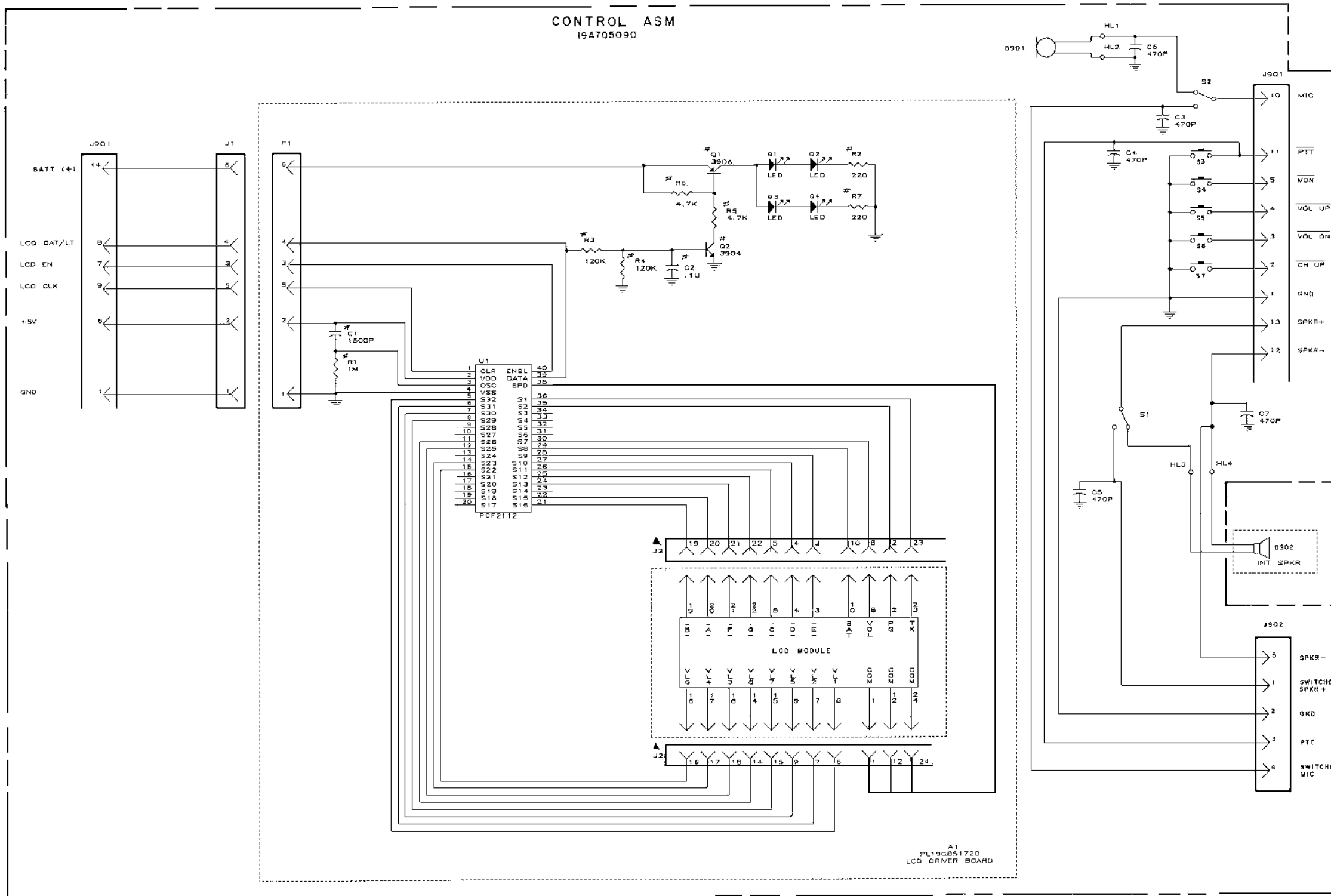

FRONT ASSEMBLY

MODEL NO.	REV. LETTER
19D902180P1 19A705090P1	A

- NOTES:
- ALL RESISTORS ARE .1 WATT UNLESS OTHERWISE SPECIFIED. RESISTOR VALUES IN Ω UNLESS FOLLOWED BY MULTIPLIER K OR M. CAPACITOR VALUES IN P UNLESS FOLLOWED BY MULTIPLIER U, N OR P. INDUCTANCE VALUES IN H UNLESS FOLLOWED BY MULTIPLIER M OR U.
 - # INDICATES CHIP COMPONENTS.
 - ▲ PART OF PWB.

FRONT CAP ASSEMBLY
19D902180G1

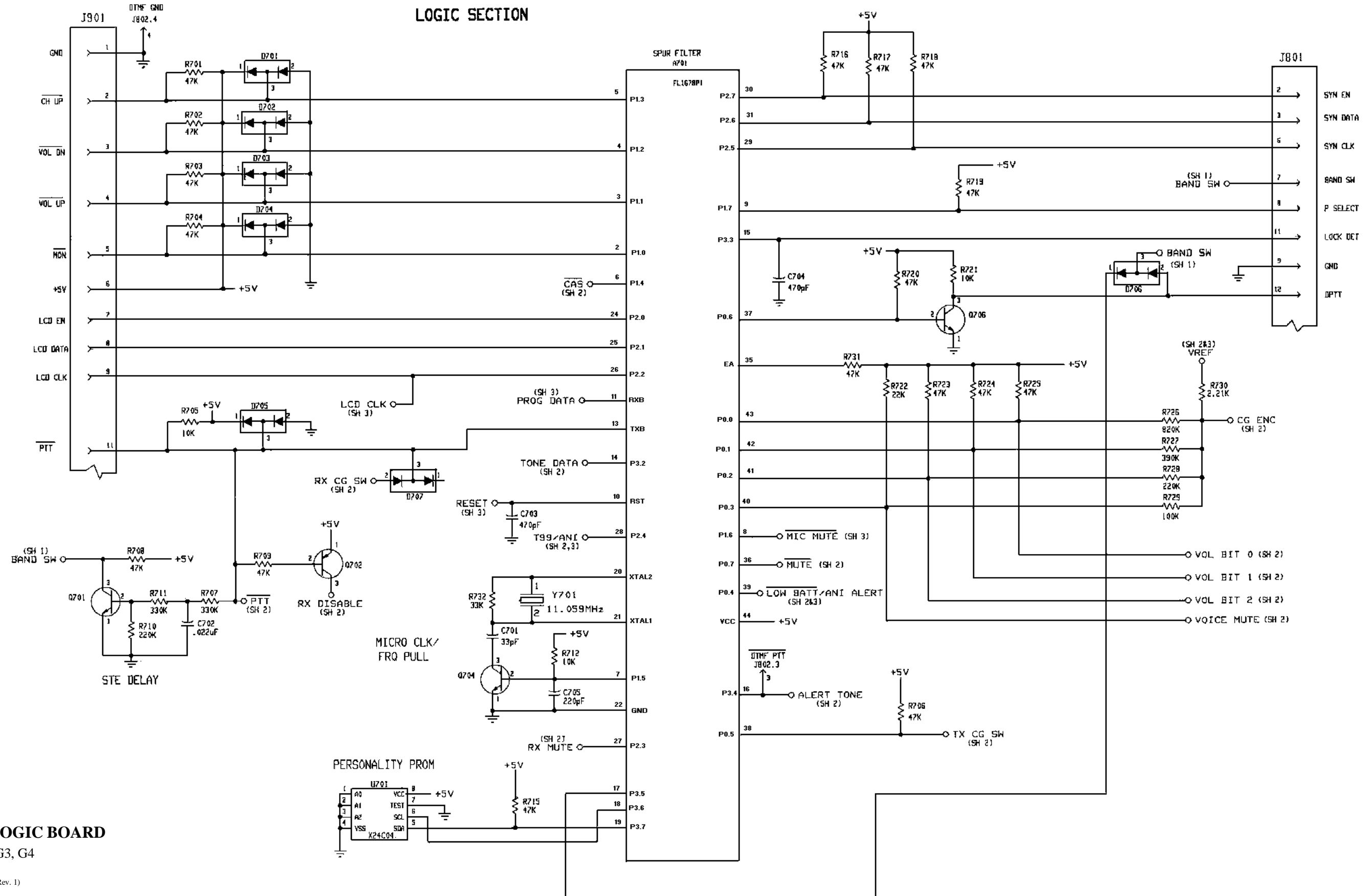

RX AUDIO SECTION

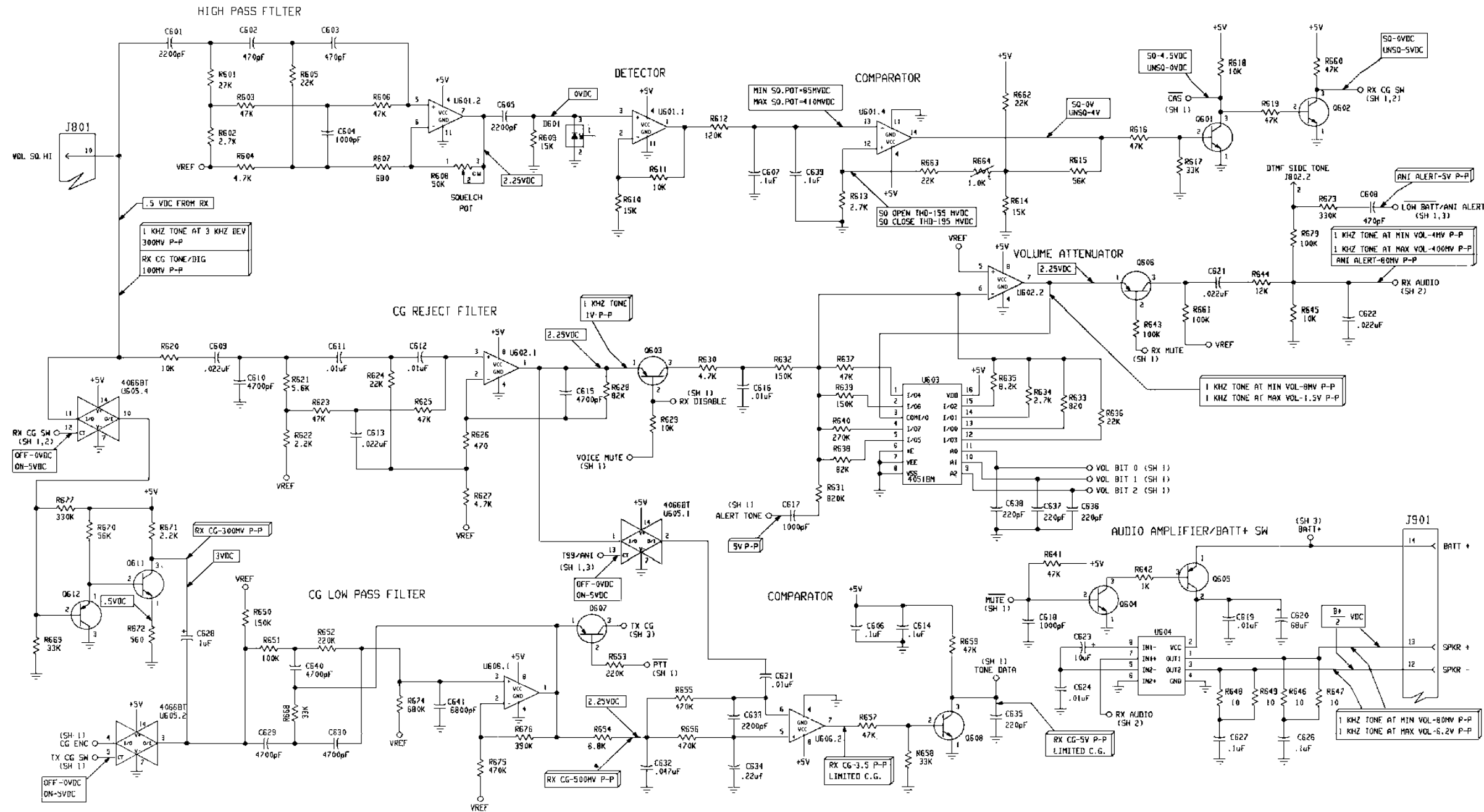

FRONT ASSEMBLY

AUDIO/LOGIC BOARD
19D902142G3 AND G4

(19D902586, Sh. 2, Rev. 1)

TX AUDIO/POWER SUPPLY SECTION

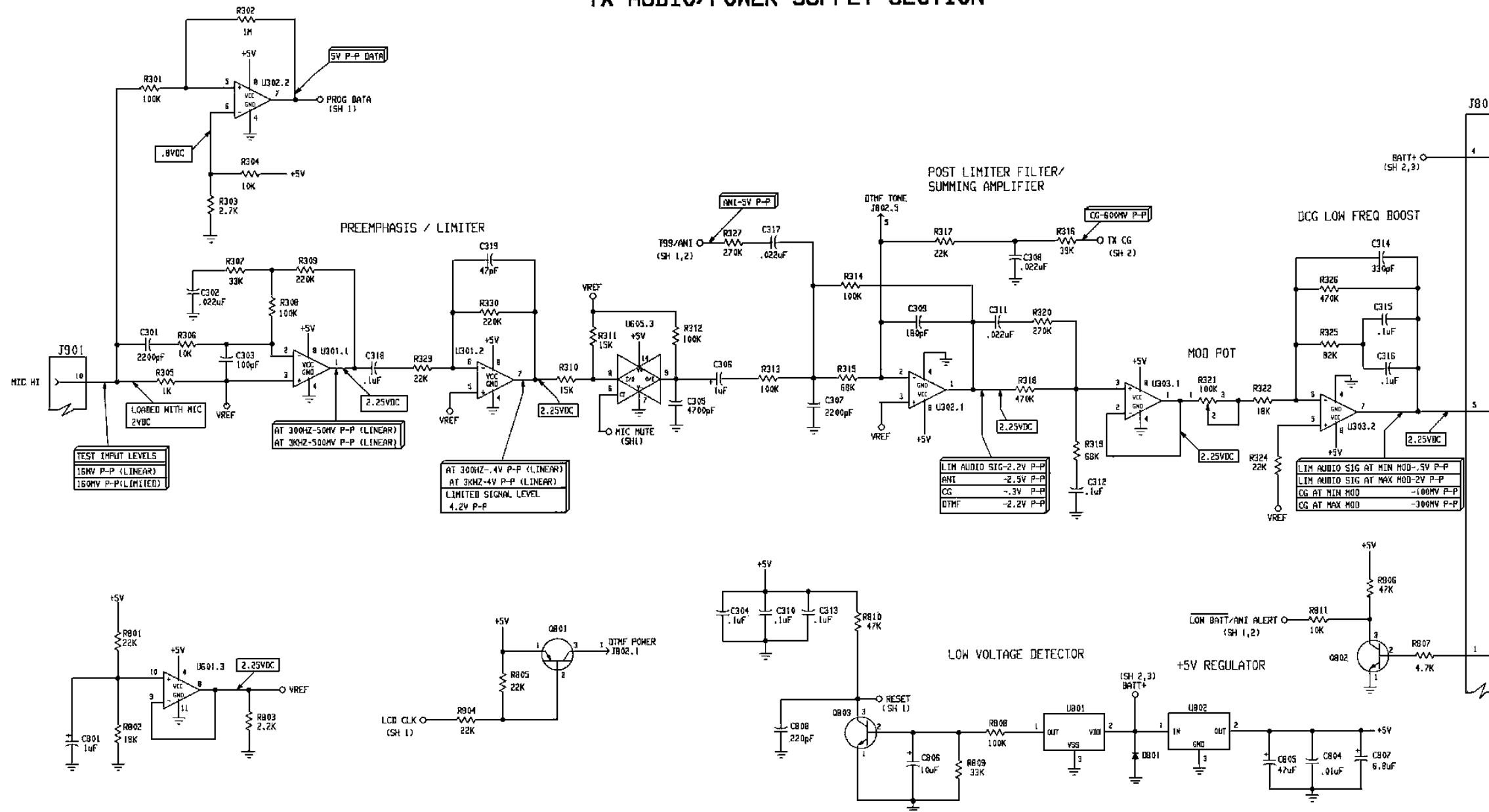

ALL RESISTORS ARE 0.1 WATT UNLESS OTHERWISE SPECIFIED AND RESISTOR VALUES ARE IN OHMS UNLESS FOLLOWED BY MULTIPLIER K OR M. CAPACITOR VALUES IN F UNLESS FOLLOWED BY MULTIPLIER U, N OR P. INDUCTANCE VALUES IN H UNLESS FOLLOWED BY MULTIPLIER H OR U.

THIS SCHEMATIC DIAGRAM APPLIES TO

MODEL NO.	REV LETTER
19D902142G3	E
19D902142G4	E

AUDIO/LOGIC BOARD

19D902142G3 AND G4

(19D902586, Sh. 1, Rev. 1)

This page intentionally left blank