

MAINTENANCE MANUAL FOR VOTER INTERFACE BOARD (19D438719G1)

TABLE OF CONTENTS

	<u>Page</u>
GENERAL THEORY	1
TEST PROCEDURE	1
Equipment Required	1
Procedure	2
PARTS LIST	3
OUTLINE DIAGRAM	4
SCHEMATIC DIAGRAM	5

GENERAL THEORY

The Voter Interface Board does the level shifting necessary to allow the GETCs to control the E & M squelch of the associated analog receiver. The RCVNG buffer provides the level shifting necessary to allow the analog voter RCVNG line to inform the digital voter selector when a site is receiving.

The E & M Squelch buffer is made up of two transistors (Q1 and Q2). Transistor Q1 is used as an open-collector driver which is tied to the E & M squelch of the analog voter. Transistor Q2 is controlled by the line from the Digital Receiver GETC at J1-2.

Another buffer is used to control the RCVNG line going to the Selector GETC. Transistor Q3 is driven by the RCVNG line (J2-2) from the analog voter. When this line goes high, the RCVNG line (J1-3) going to the GETC is pulled low.

TEST PROCEDURE

The procedure for testing the Voter Interface Board is given in the following table. Use this procedure after a repair is made to the board to verify proper operation. This procedure may also be used during troubleshooting to locate a defective component.

EQUIPMENT REQUIRED

- 13.8 Vdc Power Supply
- 100K Resistor
- Jumpers

PROCEDURE**TEST PROCEDURE**

NO.	INSTRUCTION	OBSERVATION
1.	Apply + 13.8 \pm 0.1 Vdc to J1-10	
2.	Connect power supply ground to J1-7	
3.	Connect 100K resistor from J2-1 to ground	J2-1 > 13.0 Vdc Supply current < 5mA
4.	Connect J1-2 to ground	J2-1 < 0.1 Vdc
5.	Remove ground from J1-2	J1-2 > 13 Vdc
6.	Apply + 13.8 Vdc to J2-2	J1-3 > 0.4 Vdc

**INTERFACE BOARD
19D438719G1
ISSUE 1**

SYMBOL	PART NO.	DESCRIPTION
		----- CAPACITORS -----
C1	19A701534P8	Tantalum: 22 μ F \pm 20%, 16 VDCW.
		----- JACKS -----
J1	19A704779P59	Connector, printed wiring: 10 contacts; sim to Molex 22-18-2103.
J2	19A704852P1	Connector, printed wire, two part: 2 contacts, sim to Molex 22-10-2021.
		----- PLUGS -----
P49	19B801359P4	Connector.
		-----TRANSISTORS -----
Q1	19A700022P2	Silicon, PNP; sim to 2N3906.
Q2 and Q3	19A700023P2	Silicon, NPN; sim to 2N3904
		----- RESISTORS -----
R1	H212CRP247C	Deposited carbon: 4.7K ohms \pm 5%, 1/4 w.
R2	H212CRP147C	Deposited carbon: 470 ohms \pm 5%, 1/4 w.
R3	H212CRP327C	Deposited carbon: 27K ohms \pm 5%, 1/4 w.
R4	H212CRP222C	Deposited carbon: 2.2K ohms \pm 5%, 1/4 w.
R5	H212CRP327C	Deposited carbon: 27K ohms \pm 5%, 1/4 w.
R6	H212CRP347C	Deposited carbon: 47K ohms \pm 5%, 1/4 w.
R7 and R8	H212CRP310C	Deposited carbon: 10K ohms \pm 5%, 1/4 w.

*COMPONENTS, ADDED, DELETED, OR CHANGED BY PRODUCTION CHANGES

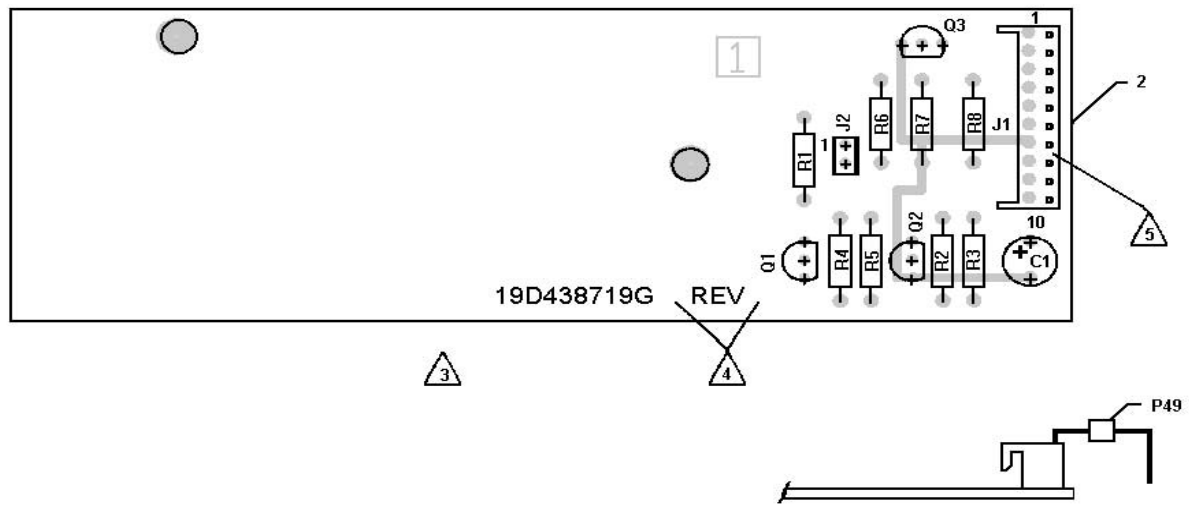

VOTER INTERFACE BOARD

(19D438719, Sh. 1, Rev. 1)
(19D438729, Sh. 1, Rev. 1)

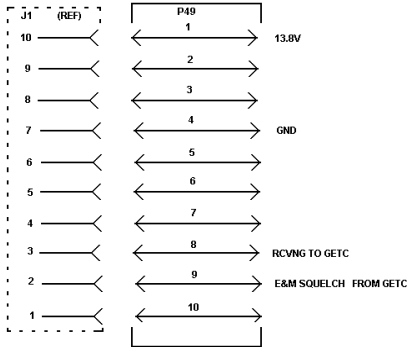

ALL RESISTORS ARE 1/4 WATT UNLESS OTHERWISE SPECIFIED AND RESISTOR VALUES IN OHMS UNLESS FOLLOWED BY MULTIPLIER K OR M. CAPACITOR VALUES IN F UNLESS FOLLOWED BY MULTIPLIER U, N OR P. INDUCTANCE VALUES IN H UNLESS FOLLOWED BY MULTIPLIER M OR U.

UNLESS MARKED OTHERWISE, ALL R.S ARE +/- 5% ALL POLARIZED CAPS ARE +/- 20% ALL OTHER CAPS ARE +/- 10%

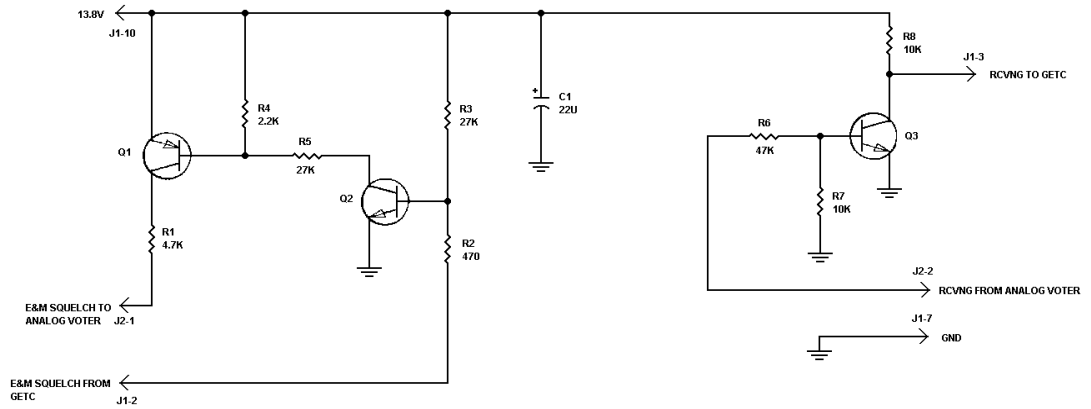

VOTER INTERFACE BOARD

(19C337197, Sh. 1, Rev. 0)

Com-Net Ericsson Critical Radio Systems, Inc.
P.O. Box 2000
Lynchburg, Virginia 24501
1-800-528-7711 (Outside USA, 804-592-7711)

Printed in U.S.A.