

Maintenance Manual

BASE STATION POWER SUPPLY

19A149978P1 - 120 VOLT/60 Hz

19A149978P2 - 230 VOLT/50 Hz

CAUTION

THESE SERVICING INSTRUCTIONS ARE FOR USE BY QUALIFIED PERSONNEL ONLY. TO AVOID ELECTRIC SHOCK DO NOT PERFORM ANY SERVICING OTHER THAN THAT CONTAINED IN THE OPERATING INSTRUCTIONS UNLESS YOU ARE QUALIFIED TO DO SO. REFER ALL SERVICING TO QUALIFIED SERVICE PERSONNEL.

WARNING: TO PREVENT FIRE OR ELECTRIC SHOCK HAZARD.
DO NOT EXPOSE THIS PRODUCT TO RAIN OR MOISTURE.

CAUTION:
TO PREVENT ELECTRIC SHOCK DO NOT USE THIS (POLARIZED) PLUG WITH AN EXTENSION CORD, RECEPTACLE OR OTHER OUTLET UNLESS THE BLADES CAN BE FULLY INSERTED TO PREVENT BLADE EXPOSURE.



 <p>The lightning flash and arrowhead within the triangle is a warning sign alerting you of "dangerous voltage" inside the product.</p>	<p>CAUTION</p> <p>RISK OF ELECTRIC SHOCK DO NOT OPEN</p> <p>CAUTION: TO REDUCE THE RISK OF ELECTRIC SHOCK. DO NOT REMOVE COVER (OR BACK). NO USER-SERVICABLE PARTS INSIDE. REFER SERVICING TO QUALIFIED SERVICE PERSONNEL.</p>	 <p>The exclamation point within the triangle is a warning sign alerting you of important instructions accompanying the product.</p>
<p>See Marking On Bottom/Back Of Product</p>		

TABLE OF CONTENTS

	<u>Page</u>
SPECIFICATIONS	3
IMPORTANT SAFETY INFORMATION	4
DESCRIPTION	6
CIRCUIT ANALYSIS	6
MAINTENANCE	7
OUTLINE DIAGRAM	11
ASSEMBLY DIAGRAMS	
60 Hz Power Supply	12
50 Hz Power Supply	16
SCHEMATIC DIAGRAMS	
60 Hz Power Supply	13
50 Hz Power Supply	17
PART LISTS	
60 Hz Power Supply	15
50 Hz Power Supply	18

NOTICE!

This manual covers Ericsson and General Electric products manufactured and sold by Ericsson Inc.

NOTICE!

Repairs to this equipment should be made only by an authorized service technician or facility designated by the supplier. Any repairs, alterations or substitution of recommended parts made by the user to this equipment not approved by the manufacturer could void the user's authority to operate the equipment in addition to the manufacturer's warranty.

NOTICE!

The software contained in this device is copyrighted by the Ericsson Inc. Unpublished rights are reserved under the copyright laws of the United States.

This manual is published by **Ericsson Inc.**, without any warranty. Improvements and changes to this manual necessitated by typographical errors, inaccuracies of current information, or improvements to programs and/or equipment, may be made by **Ericsson Inc.**, at any time and without notice. Such changes will be incorporated into new editions of this manual. No part of this manual may be reproduced or transmitted in any form or by any means, electronic or mechanical, including photocopying and recording, for any purpose, without the express written permission of **Ericsson Inc.**

SPECIFICATIONS*

OUTPUT VOLTAGE

Transmit and Receive Simultaneously	13.2 Vdc \pm 0.6 Vdc @ 29 Amps (F801B) 13.2 Vdc \pm 0.6 Vdc @ 4 Amps (J801)
Receive only	< 16.0 Vdc @ 3 Amps (J801)
Transmit only (For 225 watt PA option)	13.2 Vdc \pm 0.6 Vdc @ 33 Amps (F801B)

INPUT VOLTAGE

121 Vac \pm 20% (60 Hz version)
230 Vac \pm 15% (50 Hz version)

INPUT FREQUENCY

60 Hz \pm 2 Hz (60 Hz version)
50 Hz \pm 2 Hz (50 Hz version)

Note: For every + 1.0% change in the input frequency, the output voltage will not vary more than + 1.6% from the output voltage measured at the nominal input line frequency.

INPUT LINE SURGE PROTECTION

150 V rated MOV (60 Hz version)
275 V rated MOV (50 Hz version)

DUTY CYCLE

For 0-33 Amp output

100% (Continuous Duty)

OUTPUT VOLTAGE RIPPLE

< 100 mV p-p @ 25°C
< 200 mV p-p @ -30°C

OUTPUT TRANSIENT RESPONSE

Overshoot
Undershoot

Not to exceed 18 Volts
Not less than 11 Volts

EFFICIENCY

> 70% @ rated TX/RX load current and nominal line voltage

FUSE CAPABILITY

Input

10 Amp (60 Hz version)
(2) 5 Amp (50 Hz version)

Output

5 Amp (Low Current Port)
40 Amp (High Current Port)

DIMENSIONS (HxWxD)

5.25" x 19" x 10.35"

WEIGHT

45 lbs.

OPERATING ENVIRONMENT

-30°C To +60°C

* These specifications are intended primarily for the use of the service personnel. Refer to the appropriate Specification Sheet for the complete specifications.

IMPORTANT SAFETY INFORMATION

1. **SAVE THIS MANUAL** - It contains important safety and operating instructions.
2. Before using the product, please follow and adhere to all warnings, safety and operating instructions located on the product and in the manual.
3. **DO NOT** expose product to rain, snow or other type of moisture.
4. Care should be taken so objects do not fall or liquids do not spill into the product.
5. **DO NOT** expose product to extreme temperatures.
6. **DO NOT** use auxiliary equipment not recommended or sold by the manufacturer. To do so may result in a risk of fire, electric shock or injury to persons.
7. To reduce risk of damage to electrical cord, pull by plug rather than cord when disconnecting unit.
8. Make sure the cord is located so it will not be stepped on, tripped over or otherwise subjected to damage or stress.
9. An extension cord should not be used unless absolutely necessary. Use of an improper extension cord could result in a risk of fire and electric shock. If an extension cord must be used, make sure:
 - a. That pins on the plug of the extension cord are the same number, size and shape as those of the plug on the power supply.
 - b. That the extension cord is properly wired in good condition, and
 - c. That the wire size is large enough for AC ampere rating of unit.
10. **DO NOT** operate unit with a damaged cord or plug - replace them immediately.
11. **DO NOT** operate this product in an explosive atmosphere unless it has been specifically certified for such operation.
12. To reduce risk of electric shock, unplug unit from outlet before attempting any maintenance or cleaning.
13. **DO NOT** operate this product with covers or panels removed. This unit does not contain any user serviceable components.
14. Use only fuses of the correct type, voltage rating and current rating as specified in the parts list. Failure to do so can result in fire hazard.
15. **GROUNDING AND AC POWER CORD CONNECTION** - To reduce risk of electrical shock use only a properly grounded outlet. The unit is equipped with an electric cord having an equipment - grounding conductor and a grounding plug. Be sure the outlet is properly installed and grounded in accordance with all local codes and ordinances.
16. **DANGER** - Never alter the AC cord or plug. Plug into an outlet properly wired by a qualified electrician. Improper connection or loss of ground connection can result in risk of an electrical shock.
17. The Model 19A149978P2 is for use on a circuit having a nominal rating of 230 Vac and is factory equipped with a specific electric cord to permit connection to an acceptable electric circuit. A plug meeting local electrical codes must be supplied by the customer. Make sure the unit is connected to an outlet having the same configuration as the plug. No adapter should be used with this unit.

NOTE

A ferroresonant power supply is designed to work specifically at a given frequency. The 60 and 50 Hz supplies should be used at their nominal frequency ± 2 Hz.



Figure 1 - 60 Hz Power Supply (19A149978P1, Rev. B)



Figure 2 - 50 Hz Power Supply (19A149978P2, Rev. A)

DESCRIPTION

The ERICSSON GE MASTR® II Base Station Power Supply provides up to 435 watts to power the base station receiver, systems circuitry, and transmitter. The power supply normally will be used to provide power to a MASTR II Base Station with a maximum of 29 Amps to the power amplifier and 4 Amps for the Receiver/systems circuitry. The supply can also optionally be used to power a 225 watt power amplifier. In this case the supply is connected only to the power amplifier and will provide a maximum of 33 Amps.

The 60 Hz Model (19A149978P1) operates from a nominal 121 Vac, 60 Hz source. If a 208/220/240 Vac 60 Hz Source is to be used, an external step-down transformer (similar to 19C307148P1) must be used with the 978P 1 supply. The 50 Hz Model (19A149978P2) provides the same outputs as the '978P1 supply but operates from a nominal 230 Vac, 50 Hz source. The output voltage will change a maximum of + 1.6% for each + 1.0% change in the input line frequency.

NOTE

A ferroresonant power supply is designed to work specifically at a given frequency. The 60 and 50 Hz supplies should be used at their nominal frequency ± 2 Hz.

The power supply's step-down ferroresonant transformer provides excellent line voltage regulation. For the rated input line voltage range ($\pm 20\%$ for P1 $\pm 15\%$ for P2), the output voltage will not vary more than 2 %. A ferroresonant power supply provides inherently excellent line voltage surge protection, and reduced parts count for high reliability. No active semiconductor devices are used which could reduce reliability.

The output voltage will vary depending on the load current that the supply is being asked to source. As the load current rises, the output voltage will drop. Typically the output voltage will be 13.2 volts for a 33 Amp load, less than 16.0 volts for a 3 Amp load, and less than 16.7 volts for no load.

The operation and servicing of the power supply are completely accessible from the front. The ON/OFF switch and all fuses are located on the front panel. The low profile slot type fuse holders contain the primary fuse F1 (F1 & F4 for 978P2) and the low current output fuse F3. The high current output fuse F2 is mounted behind the front panel fuse cover. The primary fuse F1 (F1 & F4 for 978P2) protects the input wiring to the ferroresonant transformer (10 Amps for P1, 5 Amps each for P2). The output fuses F2 (40

Amps) and F3 (5 Amps) provide external overload protection.

The 60 Hz supply provides a courtesy dual AC receptacle. The primary line current fuse (F1) also provides over-current protection for the dual receptacle. The 60 Hz supply draws 5 Amps under nominal conditions and 7 Amps under all extremes. Thus, the dual courtesy receptacles are rated to provide a line current of 3 Amps.

CIRCUIT ANALYSIS

In the 60 Hz power supply (978P 1), the ON/OFF switch (S1) provides line voltage to the power supply through the primary line fuse F1. In the Rev. B version, line voltage flows through F1 to the courtesy receptacles prior to S1. This allows line voltage to always be available at the receptacles. In previous models (Rev. A and earlier), S1 applies line voltage to F1 and the courtesy receptacles in turn. Current then flows through the primary of step-down transformer (T1) via the 200°C thermal fuse. The thermal fuse would only open in the unlikely event that an internal short would develop in the transformer. The Varistor (VR1 - 150 V rating) provides additional input line voltage suppression.

In the 50 Hz power supply (978P2), the ON/OFF switch (S1) is a DPST type switching both primary AC lines. In addition, both input lines have 5 Amp fuses (F1 and F4). The Varistor (VR1 - 275 V rating) provides additional input line voltage suppression. When power is applied, current flows through the primary of step-down transformer (T1) via the 200°C thermal fuse. As in the 60 Hz model, the thermal fuse will open if the transformer develops an internal short.

The step-down transformer is a ferroresonant type which has inherently good input line voltage regulation - eliminating the need for additional high-current regulators. C1 serves as a resonating capacitor across the secondary taps of the transformer.

The transformer steps the input voltage down to approximately 14 volts (for a 33 Amp load) and 16 volts (for a 3 Amp load). It then applies the stepped-down voltage to the full wave rectifier circuitry consisting of D1A,B through D3A,B and the high current filter. The rectifiers are dual diode packages and are mounted on heat sink HS1.

The high current filter consists of C2-C7 and L1. It is designed to reduce the output ripple to less than 100 mV p-p for any current load up to 33 Amps. It also keeps transient responses greater than 11 and less than 18 volts. Resistor R1 is a 10 ohm, 50 watt resistor that serves two functions. One, it acts as a bleeder resistor to discharge the capacitors when the supply is turned off. Two, it provides a minimum current

load to prevent the output voltage from ever rising above 18 volts under any load condition. Under normal conditions jumper P802 is installed connecting the bleeder resistor (SW GND) to A-. In 60 Hz models (Rev. A and earlier), prior to Rev. B, this is done using a ground strap externally connected between F801B-2 and F801B-3. When the emergency power option is used, the jumper or ground strap is removed. This allows the relay K3 in charger 344A3168 to ground or open the bleeder resistor. When line voltage is present, the relay grounds the bleeder resistor to A-. In an emergency power condition, the relay open-circuits the bleeder resistor preventing premature drainage of the battery powering the station.

The high current filter sources current to both the high current and the low current output ports. It can source up to 33 Amps through 40 Amp fuse (F2) to the high current terminal strip (F801B) on the rear wall of the power supply chassis. F801B-1 and F801B-2 are A + and A-, respectively, and connect to the transmitter power amplifier. For base stations that do not have emergency power options, F801B-3 and F801B-4 are not used. For emergency power options, F801B-3 & 4 provide connection between the power supply and the charger. In an emergency power condition, the external battery is connected through the charger, and through the power supply, to provide emergency power for the base station.

The high current filter sources up to 4 Amps through 5 Amp fuse (F3) to the 9 pin molex connector (J801). This port provides power to the receiver and system circuitry in the base station. J801-1,2,3 are A + and J801-4,5,6 are A-. An internal jumper between J801-7 and -8 allows a feedthru for the optional emergency power status line. J801-9 provides SW GND for the emergency power options.

The power supply is rated for a nominal 13.2 Vdc for a 29 Amp load out of F801B and a 4 Amp load out of J801 (receiving and transmitting simultaneously). When receiving only (a 3 Amp load out of J801), the output voltage is less than 16.0 Vdc.

MAINTENANCE

For disassembly, remove 8 screws and lift off top cover. Disassembly is required before working on the power supply. When replacing any component be certain to use an identical component. Thermal joint compound is required between diodes D1, D2 and D3 and the heat sink.

WARNING

To avoid electrical shock, disconnect power supply from the AC input power source before removing or replacing any component or assembly.

TROUBLE-SHOOTING

The trouble-shooting procedure in Table 1 may be helpful in isolating a defective component or assembly in a malfunctioning power supply. When a component or assembly is identified as defective, replace the defective component with an identical component. Be sure to check associated circuitry for any other damaged components before applying power to the unit.

ADJUSTMENTS

This power supply has no adjustments or controls other than the ON/OFF switch.

INSTALLATION

The power supply is normally installed in an EIA 19 inch wide rack of a MII base station cabinet. It can also be installed in a 19 inch wide stand alone open rack.

NOTE

Insure that ventilation holes in the unit are not obstructed when the unit is mounted or in operation.

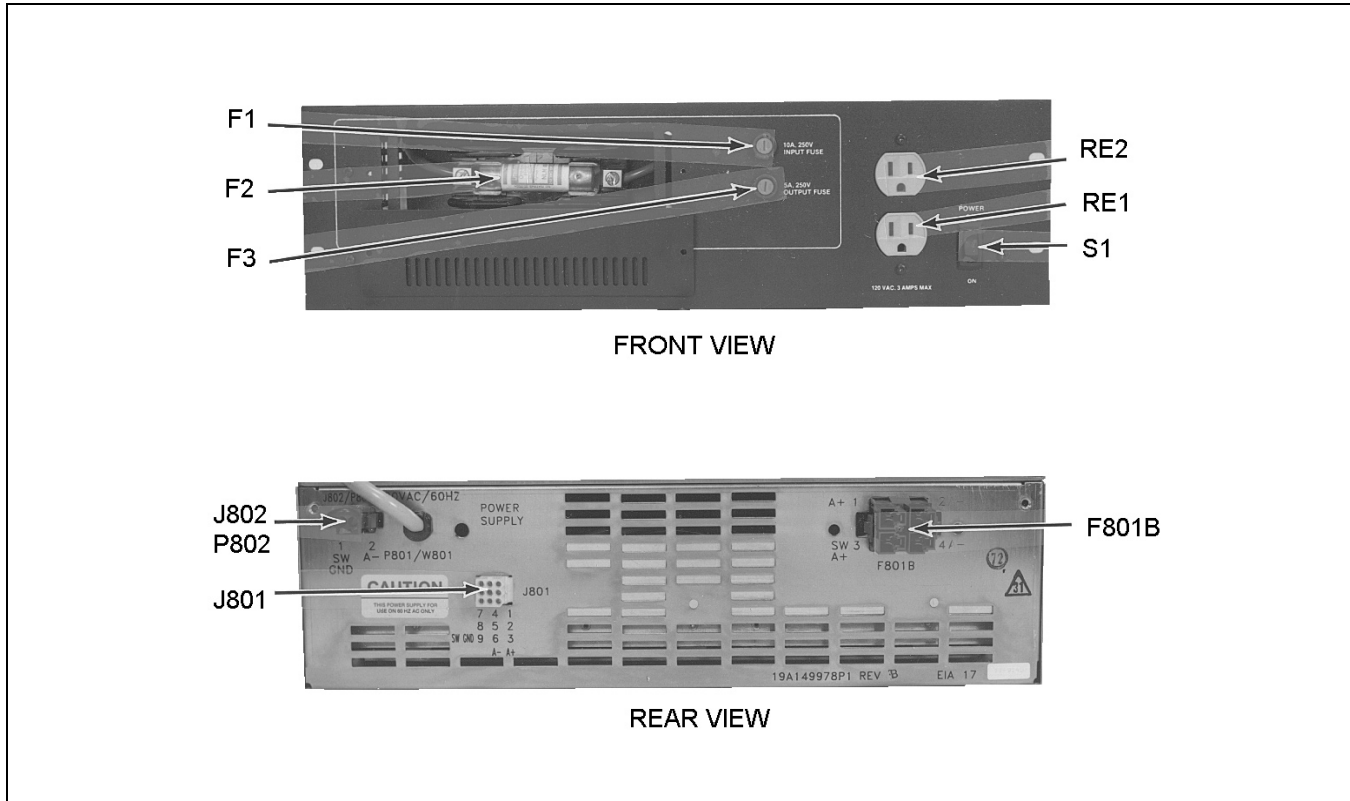

Figure 3 - 60 Hz Power Supply (19A149978P1, Rev. B)

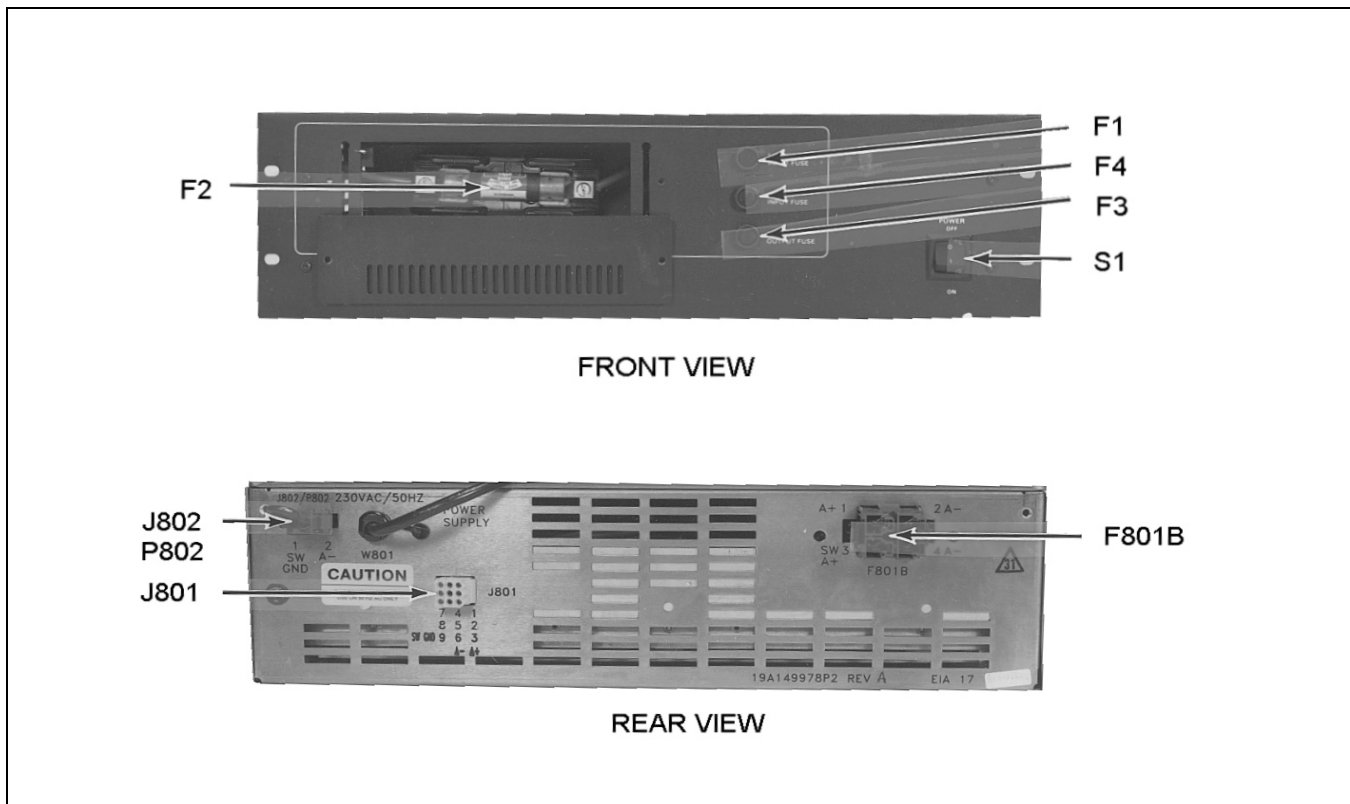

Figure 4 - 50 Hz Power Supply (19A149978P2, Rev. A)

FUSE REPLACEMENT

To replace a defective fuse, perform the following procedure:

1. Place ON/OFF switch to the OFF position.
2. For fuses F1 (F1 & F4 on 978P2) or F3, remove cap from fuse holder and replace fuse with a fuse of the same type and rating.
3. For fuse F2, remove two screws holding fuse cover to front panel. Remove defective fuse and replace with a fuse having the same type and rating. Replace fuse cover and secure using the 2 screws.

WARNING

To avoid possible electric shock, **DO NOT** operate this power supply with the fuse cover removed.

WARNING

No one should be permitted to handle any portion of the equipment that is supplied with high voltage, or to connect any external apparatus to the units while the units are supplied with power. **KEEP AWAY FROM LIVE CIRCUITS.**

Table 1 - 60 Hz Power Supply 19A149978P1

SYMPTOM	PROCEDURE
No output voltage at J801	Check the following:
	1. Open F1, F3 or S1.
	2. AC voltage on W801.
	3. Open D1, D2 or D3.
No output voltage at F801B	Check the following:
	1. Open F1, F2 or S1.
	2. AC voltage on W801.
	3. Open D1, D2 or D3.
Low output voltage on F801B or J801.	Check the following:
$0 < V_o < 12.5 \text{ Vdc}$	1. If one of the dual diodes on D1, D2 or D3 is shorted. NOTE: All three diode packages contain two diodes each.
	2. Line frequency < 60 Hz.
High output voltage on F801B or J801.	Check the following:
	1. Spade jumper is connected between pos 2 and 3 on F801B. (Rev. A and earlier).
$V_o . > 16.7 \text{ Vdc}$	Plug P802 is connected to connector J802. (Rev. B and later).
	2. R1 not connected between pos 1 and 3 on F801B.
	3. Line frequency > 60 Hz.

Table 2 - 50 Hz Power Supply 19A149978P2

SYMPTOM	PROCEDURE
No output voltage at J801	Check the following:
	1. Open F1, F3, F4 or S1.
	2. AC voltage on W801.
	3. Open D1, D3 or D3.
No output voltage at F801B	Check the following:
	1. Open F1, F2, F4 or S1.
	2. AC voltage on W801.
	3. Open D1, D2 or D3.
Low output voltage on F801B or J801.	Check the following:
$0 < V_o < 12.5 \text{ Vdc}$	1. If one of the dual diodes on D1, D2 or D3 is shorted. NOTE: All three diode packages contain two diodes each.
	2. Line frequency < 50 Hz.
High output voltage on F801B or J801.	Check the following:
	1. Plug P802 is connected to connector J802.
$V_o . > 16.7 \text{ Vdc}$	2. R1 not connected between pos 1 and 3 on F801B.
	3. Line frequency > 50 Hz.

COMPONENT SIDE

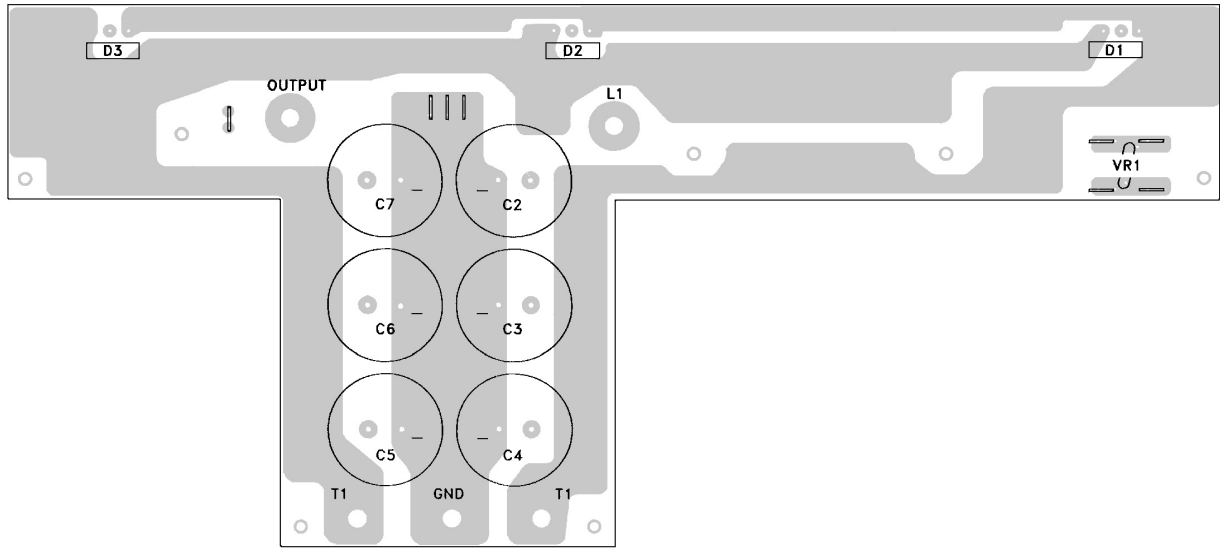

(33014904, Rev. F)
(33014900, Sh. 1, Rev. F)

SOLDER SIDE

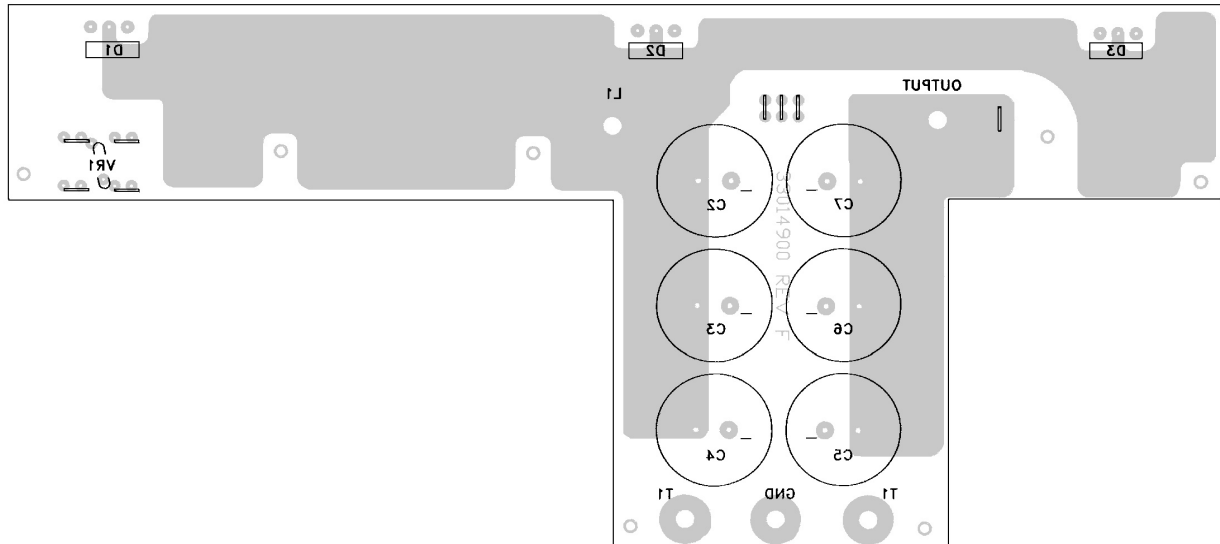

(33014904, Rev. F)
(33014900, Sh. 2, Rev. F)

PRINTED CIRCUIT BOARD
50 HZ AND 60 HZ MODELS

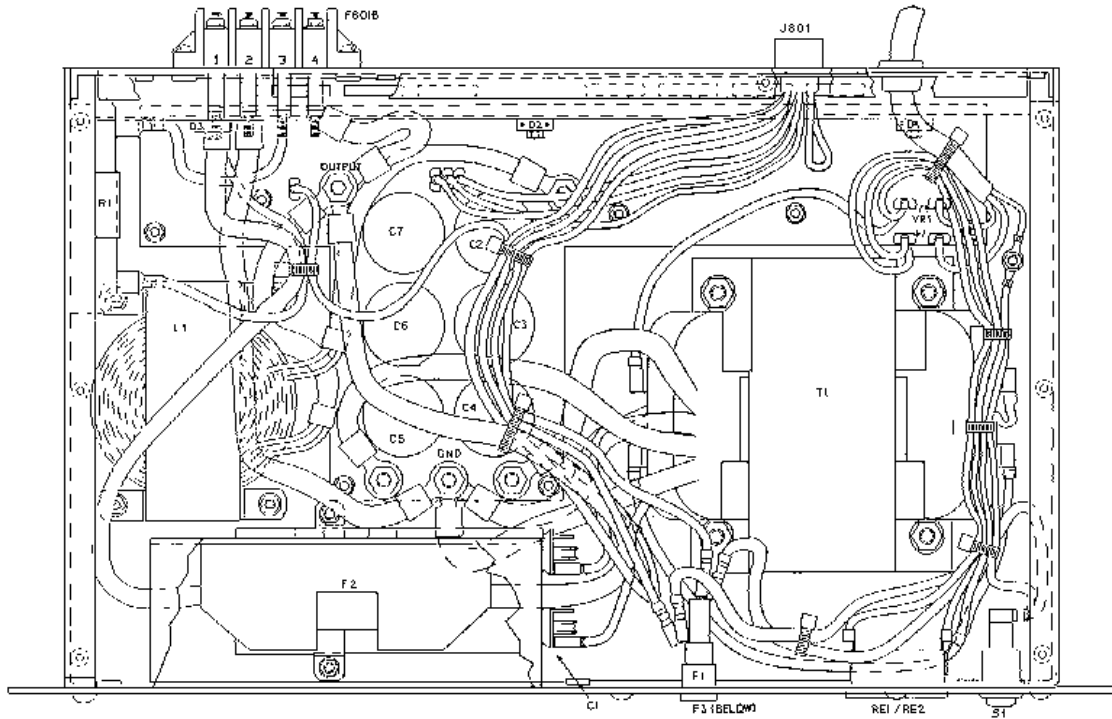

Rev. 0 & Rev. A

(Made from 289PS1, Rev. A)

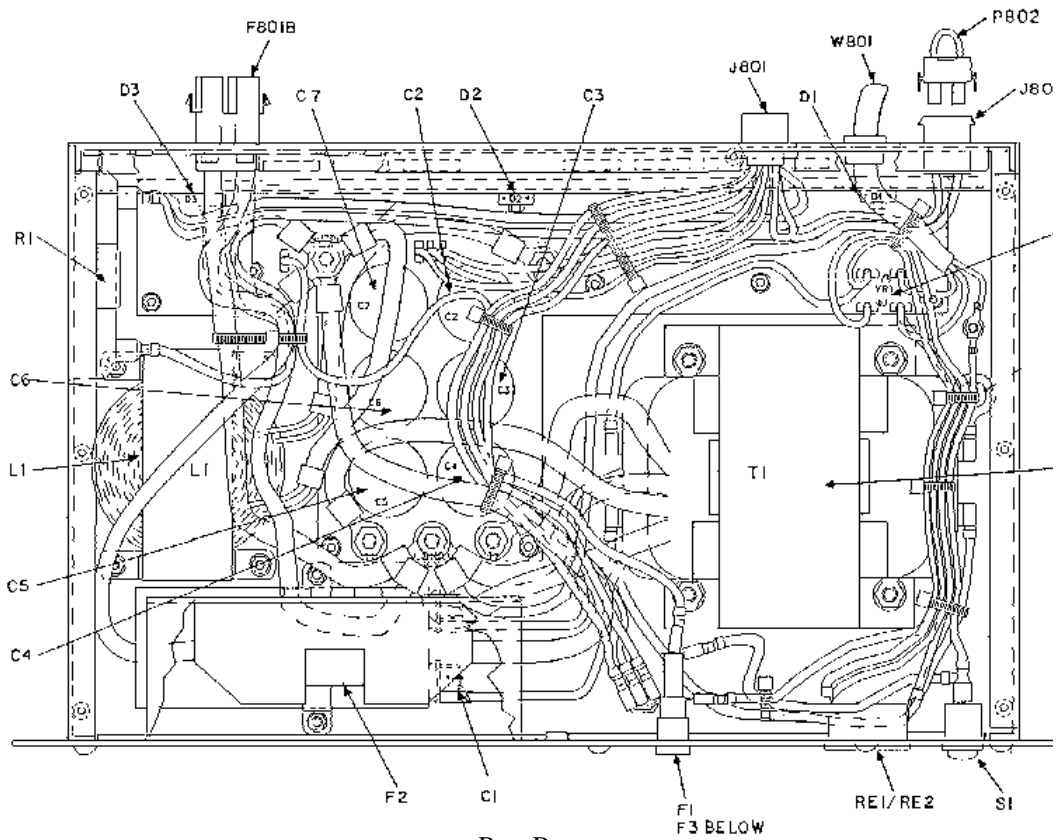

Rev. B

(Made from 289PS11, Sh. 2, Rev. A)

60 HZ POWER SUPPLY

19A149978P1

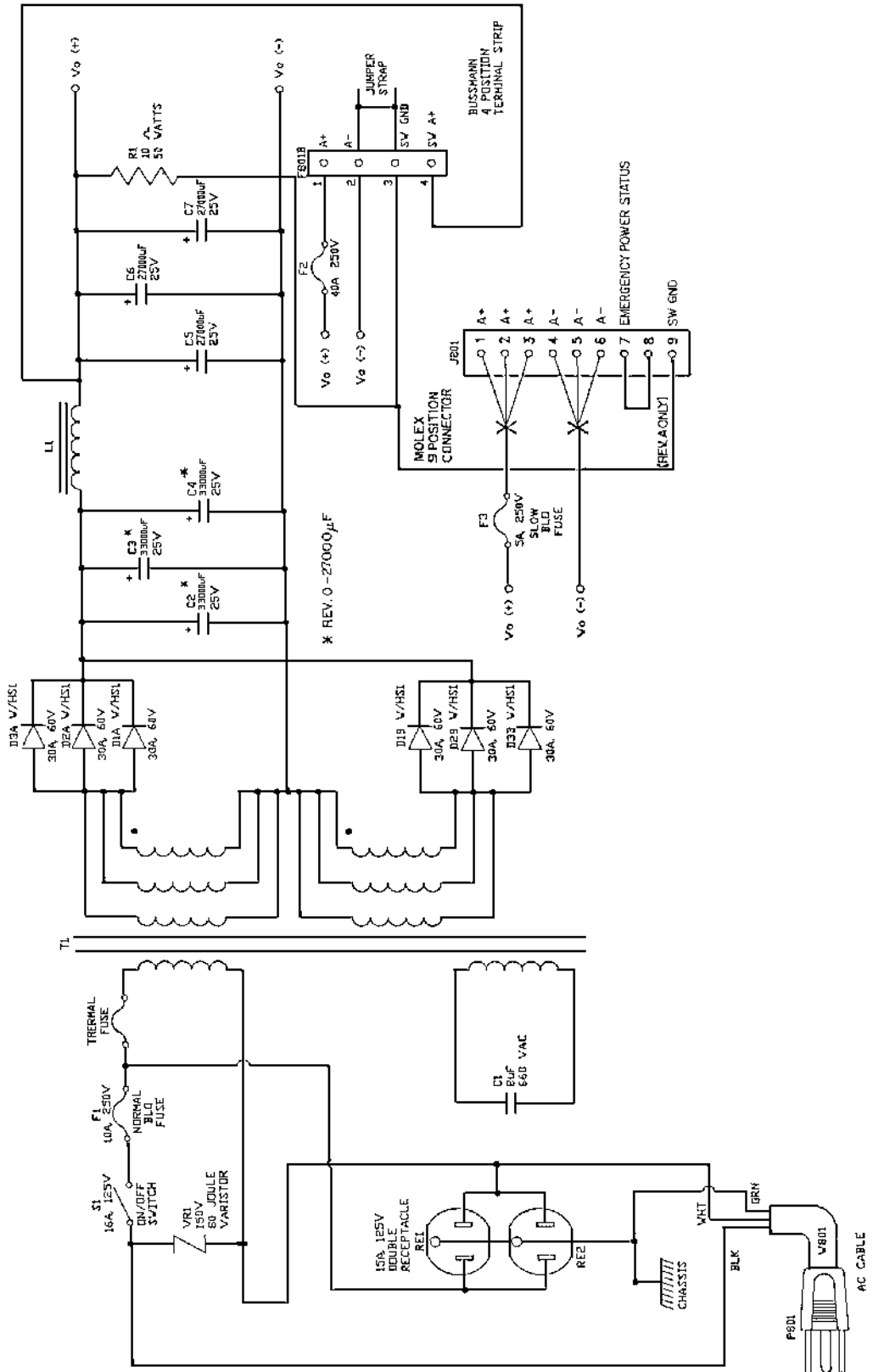

60 HZ POWER SUPPLY
19A149978P1, Rev. 0 & Rev. A

(289PS1, Sh. 1, Rev. 1)

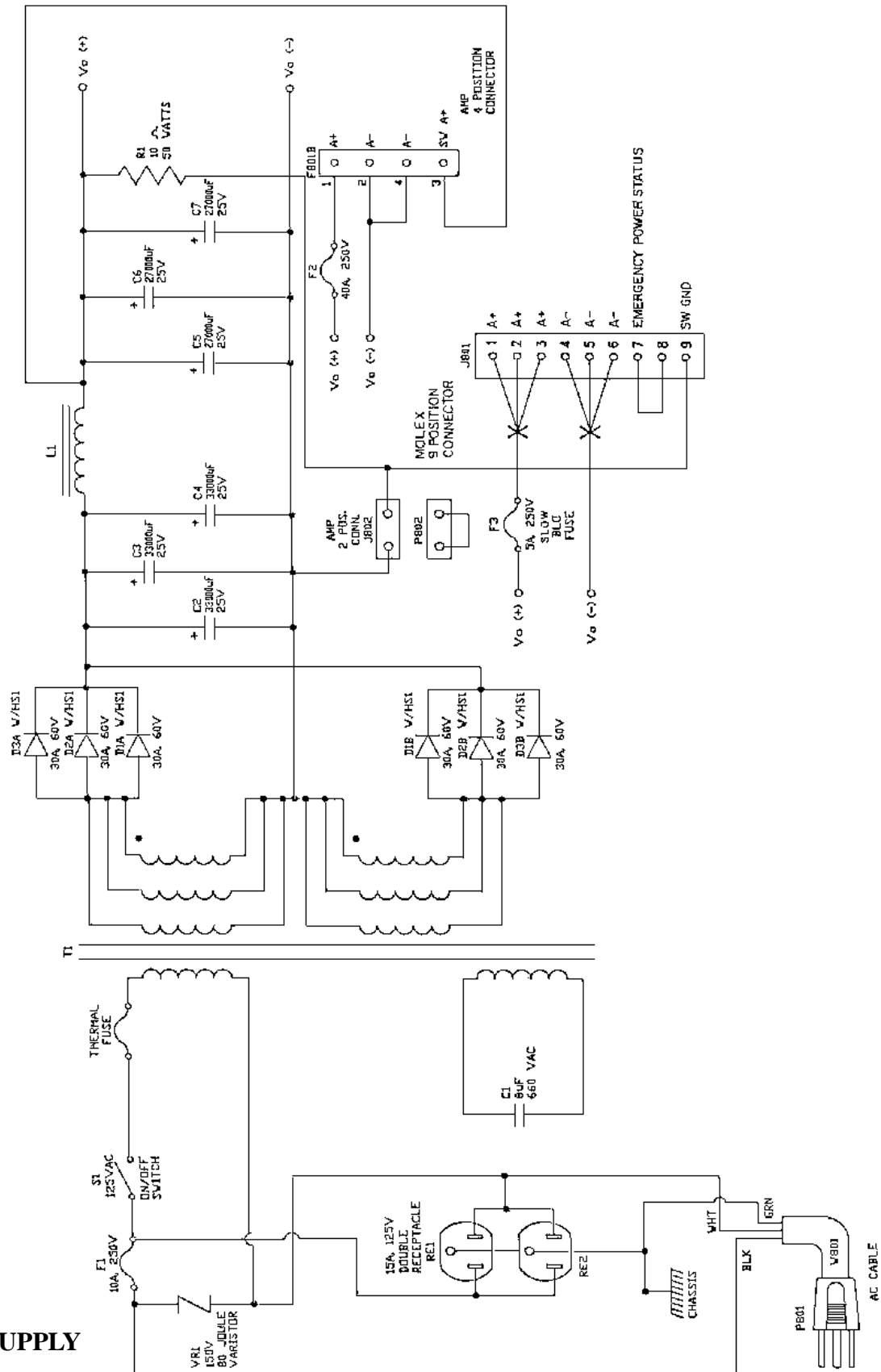

60 HZ POWER SUPPLY
19A149978P1, Rev. B

(289PS11, Sh. 1, Rev. A)

STATION POWER SUPPLY
19A149978P1
ISSUE 2

SYMBOL	GE PART NO.	DESCRIPTION
		----- CAPACITORS -----
C1	M29/17032400	Polypylene: 8 uF, 660Vac. similar to Ronken P61A24805R05.
		----- FUSES -----
F1	M29/09013901	Non-time delay Glass/Ferrule Fuse: 10 amps, 250V; similar to Bussmann AGC-10.
F2	M29/09015200	Quick blowing Fuse: 40 amps, 250V; similar to Bussmann NON-40.
F3	M29/09016300	Slow Blow Fuse: 5 amps, 250V; similar to Bussmann MDL-5.
		----- FUSE HOLDER & BLOCKS -----
	M29/09014200	Fuse Holder, screwdriver slot design: similar to Bussmann "HTB-961". (Used with F1 and F3).
	M29/09014100	Fuse Block: 31A to 60 amps, 250V; similar to Bussmann H25060-1C. (Used with F2).
		----- TERMINAL BLOCKS -----
F801B	M29/30090900	Terminal Strip: 45 amps, 250V, 4 position; sim to Bussmann 480304-NL. (REV. 0 and REV. A)
F801B	M29/25011000	Connector: 4 position; sim to AMP 641685-2. (REV. B only)
		----- CONNECTOR -----
J801	M29/40027400	Connector: 9 position; sim to Molex 03-09-1091.
J802	M29/40028400	Connector: 2 position; sim to AMP 350778-1. (Used in REV. B only)
P802	M29/40028300	Connector: 2 position; sim to AMP 350777-1. (Used in REV. B only)
		----- INDUCTOR -----
L1	M29/289C3	Output choke: .8 mH, 33 amps; similar to MagneTek 289C3. Includes W25 and W25.
		----- RESISTORS -----
R1	M29/16012301	Wirewound Resistor: 10 ohms, 50 w; similar to IRC PW-50E-100HMS-5% (with bracket).
		----- RECEPTACLES -----
RE1 and RE2	M29/40027800	Receptacle: power, 3 wire grounding, 15 amps at 125V; similar to GE 5242-9.
		----- SWITCHES -----
S1	M29/20003300	SPST: 16 amps, 125V switch; similar to carling RA911VBBOV.
		----- TRANSFORMER -----
T1	M29/289CV1	Ferro-Resonant Transformer. (REV. 0 only)
T1	M29/289CV5	Ferro-Resonant Transformer. (REV. A and later)
		----- WIRE HARNESS -----
W1 THRU W30	M29/289LW1	WIRING HARNESS. (REV. 0)
W1 THRU W30	M29/289LW1	WIRING HARNESS. (REV. A)
W31		Wire, black: J801 pin 9 to R1. (REV. A)
W1 THRU W34	M29/289LW11	WIRING HARNESS. (REV. B)
		----- MISCELLANEOUS -----
	M29/07057300	Front Fuse Cover. (REV. 0 only)
	M29/07063300	Front Fuse Cover. (REV. A and later)

*COMPONENTS ADDED, DELETED OR CHANGED BY PRODUCTION CHANGES

SYMBOL	GE PART NO.	DESCRIPTION
	M29/07056600	Top Cover. (REV. 0 only)
	M29/07062200	Top Cover. (REV. A and later)
	M29/07056700	Front Panel. (REV. 0 only)
	M29/07062300	Front Panel. (REV. A and later)
	M29/07057400	Back Cover.
	M29/22043800	Machine screw, torx head: 3.5m x 1/2; similar to Camcar/Textron Inc. Secures cover.
	M29/22027709	Machine screw, hex head; No. 6-32 x .625" secures C1 to case.
	M29/22041502	Hex nut: No. 8-32, secures C1, R1, L1 and ground wire to case.
	M29/05065600	Bracket for C1; similar to GE K9827065P21.
	M29/22041501	Hex nut: No. 6-32 x .250, secures PCB.
	M29/22043200	Nylon Standoff, to keep PCB from case.
	M29/11022000	Strain relief, black similar to Heyco "1200". To secure W801 to case.
	M29/22008708	Machine Screw: 10-32 X 5/8", to secure fuse block to front panel and terminal block (F801B to case, REV. 0 and REV. A only).
	M29/22041504	ARCFILT NUT: 1/4-20 x 7/16, secures T1 to case
		HEAT SINK / PCB ASSEMBLY M29/11022900 (REV. 0 only) M29/11024600 (REV. A and later) (Assembly includes the following:)
		----- CAPACITORS -----
C2 thru C4		Aluminum electrolytic: 27000 uF, 25V; sim to UCC XME25VB273M35X50LL. (REV. 0 only)
C2 thru C4		Aluminum electrolytic: 33000 uF, 25V; sim to UCC XME25VB333M35X50LL. (REV. A and later)
C5 thru C7		Aluminum electrolytic: 27000 uF, 25V; sim to UCC XME25VB273M35X50LL.
		----- RECTIFIERS -----
D1 thru D3		Dual Schottky Rectifier: 30 amps, 60V; similar to G1 MBR3060.
		----- VARISTOR -----
VR1		Variator: 150V, 80j metal oxide; similar to GE V150LA20A.
		----- TERMINALS -----
TB1 thru TB8		FASTON tabs: similar to MagneTek "13048100".
		----- MISCELLANEOUS -----
W1 thru W5		ARCFILT NUT: 1/4-20, secures wire to PCB.
SCL thru SC5		Screw, Hex head: 1/4-20 x .750 in.
W1 thru W5		Lock Washer: 1/4 internal tooth secures wire to PCB.
		Heatsink: .063" thick aluminum heat sink; similar to MagneTek 11021900.
		Hex head screw: No. 4-40 x .5 with washer to secure D1-D3 to heat sink.
		ARCFILT 4-40 nut: UNC-2B 1/4 in., used to secure D1-D3 to heat sink.
		Heat Transfer Pad: To insure good thermal conductivity between D1-D3 and heat sink.
		Lock Washer: No. 4; used to secure D1-D3 to heat sink.

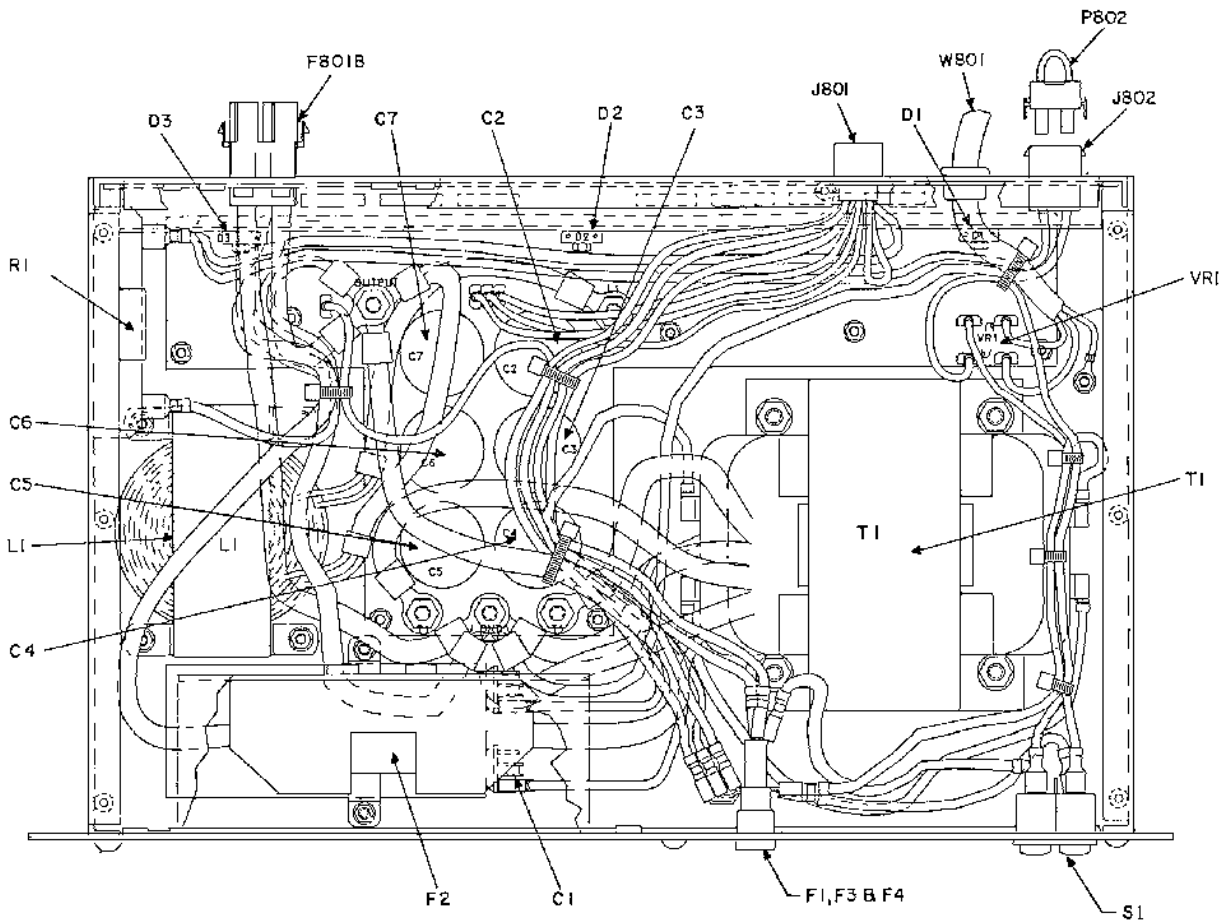

(Made from 289PS2, Sh. 2, Rev.Q)

50 HZ POWER SUPPLY

19A149978P2

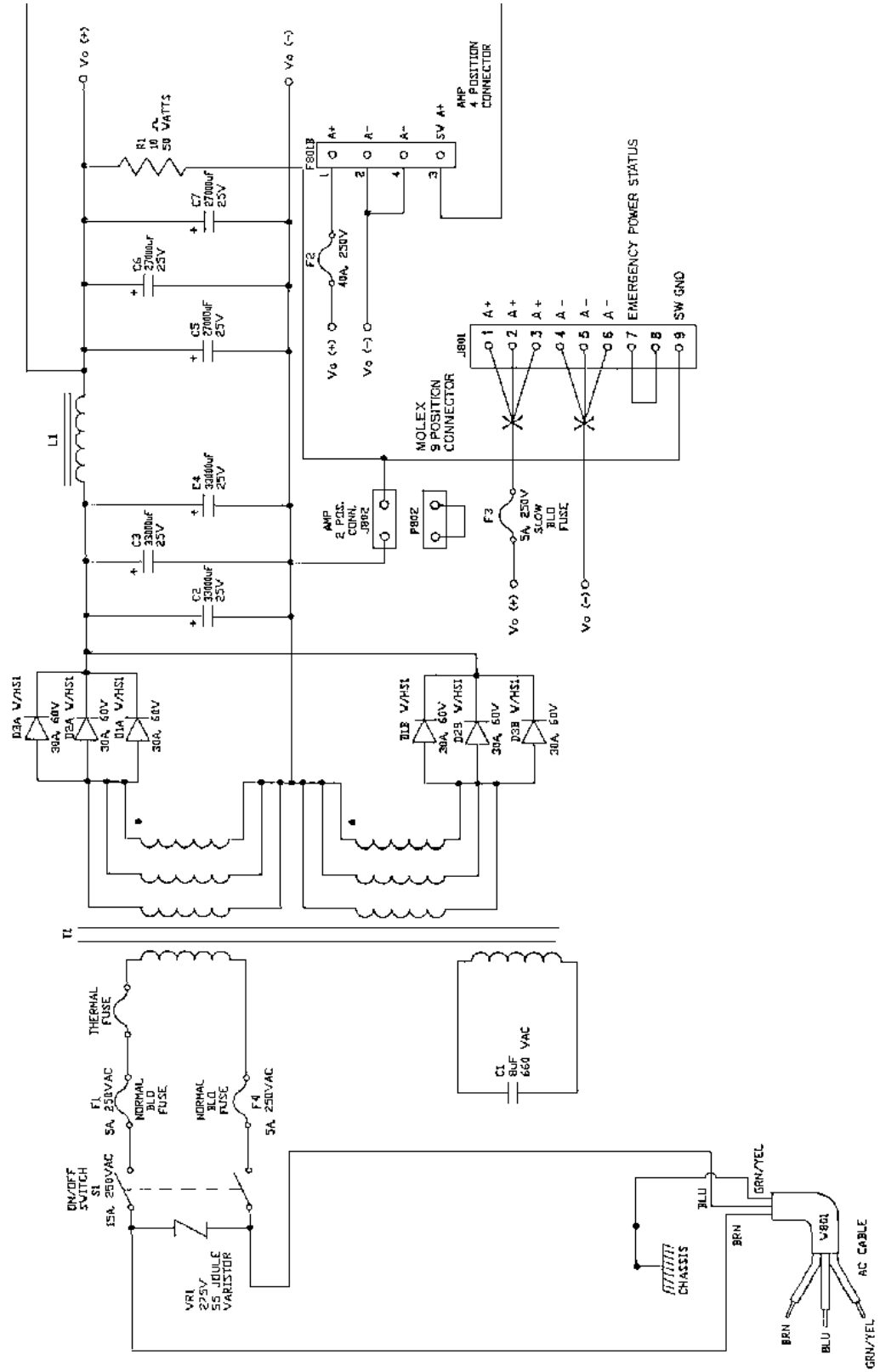

50 HZ POWER SUPPLY
19A149978P2

(289PS2, Sh. 1, Rev. H)

STATION POWER SUPPLY
15A14978P2
ISSUE 1

SYMBOL	GE PART NO.	DESCRIPTION
		----- CAPACITORS -----
C1	M29/17032400	Polypropylene: 8 uF, 660Vdc, similar to Ronken P61A24805H05.
		----- FUSES -----
F1	M29/09016000	Quick acting Ceramic/Ferrule Fuse: 5 amps, 250V; similar to Bussmann GDA-5.
F2	M29/09015200	Quick blowing Fuse: 40 amps, 250V; similar to Bussmann NON-40.
F3	M29/09016000	Quick acting Ceramic/Ferrule Fuse: 5 amps, 250V; similar to Bussmann GDA-5.
F4	M29/09016000	Quick acting Ceramic/Ferrule Fuse: 5 amps, 250V; similar to Bussmann GDA-5.
		----- FUSE HOLDER & BLOCKS -----
	M29/09016100	Fuse Holder, screwdriver slot design: similar to Bussmann HTB-96M. (Used with F1, F3, and F4).
	M29/09014100	Fuse Block: 31A to 60 amps, 250V; similar to Bussmann H25060-1C. (Used with F2).
		----- TERMINAL BLOCKS -----
F801B	M29/25011000	Connector: 4 position; sim to AMP 641685-2.
		----- CONNECTOR -----
J801	M29/40027400	Connector: 9 position; sim to Molex 03-09-1091.
J802	M29/40028400	Connector: 2 position; sim to AMP 35077B-1.
P802	M29/40028500	Connector: 2 position; sim to AMP 350777-1.
		----- INDUCTOR -----
L1	M29/289C3	Output choke: .8 mH, 33 amps; similar to MagneTek 289C3. Includes W25 and W25.
		----- RESISTORS -----
R1	M29/16012301	Wirewound Resistor: 10 ohms, 50 w; similar to IRC PW-50E-100HMS-5W (with bracket).
		----- RECEPTACLES -----
RE1 and RE2	M29/40027800	Receptacle: power, 3 wire grounding, 15 amps at 125V; similar to GE 5242-9.
		----- SWITCHES -----
S1	M29/20003900	DPST.
		----- TRANSFORMER -----
T1	M29/289CV2	Ferro-Resonant Transformer.
		----- WIRE HARNESS -----
W1 THRU W36	M29/289LW12	WIRING HARNESS.
		----- MISCELLANEOUS -----
	M29/07063300	Front Fuse Cover.
	M29/07062200	Top Cover.
	M29/07063600	Front Panel.
	M29/22043800	Machine screw, torx head: 3.5m x 1/2, secures cover.
	M29/22041502	Hex Nut: No. 8-32, secures C1, L1, R1, and ground wire to case.
	M29/05065600	Bracket for C1.
	M29/22041501	Hex nut: No. 6-32, secures PCB, and heat sink.
	M29/22043200	Nylon Standoff, to keep PCB from case.

*COMPONENTS ADDED, DELETED OR CHANGED BY PRODUCTION CHANGES

SYMBOL	GE PART NO.	DESCRIPTION
	M29/11023900	Strain relief. To secure W801 to case; sim to Keyco 3772.
	M29/22008708	Machine Screw: 10-32 X 5/8". to secure fuse block to front panel).
	M29/22041504	ARCPLT NUT: 1/4-20, secures T1 to case
		HEAT SINK / PCB ASSEMBLY M29/11023901 (Assembly includes the following:)
		----- CAPACITORS -----
C2 thru C4		Aluminum electrolytic: 33000 uF, 25V; sim to UCC KME25VB33M35X50LL.
C5 thru C7		Aluminum electrolytic: 27000 uF, 25V; sim to UCC KME25VB27M35X50LL.
		----- RECTIFIERS -----
D1 thru D3		Dual Schottky Rectifier: 30 amps, 60V; similar to GI WBR3060.
		----- VARISTOR -----
VRI		Varistor: 275V, 55j metal oxide; similar to GE V275LA20A.
		----- TERMINALS -----
TB1 thru TB8		FASTON tabs; sim to AMP 62650-1.
		----- MISCELLANEOUS -----
N01 thru N05		Keeper Nut: 1/4-20, secures wire to PCB.
SC1 thru SC5		Screw, Hex head: 1/4-20 x .750 in.
		Heatsink: .063" thick aluminum heat sink; sim to MagneTek 11024400.
		Heat Transfer Pad: To insure good thermal conductivity between D1-D3 and heat sink.
		Hex head screw: No. 4-40 x .5 with washer to secure D1-D3 to heat sink.
		ARCPLT 4-40 nut: UNC-2B 1/4 in., used to secure D1-D3 to heat sink.
		Lock Washer: No. 4; used to secure D1-D3 to heat sink.