

LBI-38623A

Maintenance Manual

Service Section for
PCS Personal Radios

TABLE OF CONTENTS

	<u>Page</u>
INTRODUCTION	1
ADJUSTMENT	1
PROGRAMMING	2
PREVENTIVE MAINTENANCE	2
DISASSEMBLY PROCEDURE	2
TROUBLESHOOTING	2
Documentation Required	2
Problems	2
Display Problems	2
RX Audio Problems	2
TX Problems	2
Procedure	2
Display Problems	2
Receive Problems	2
Scan Problems	3
Transmit Problems	3
Synthesizer	4
Reference Oscillator	4
VCO U204	4
Prescaler U202	4
Bilateral Switch U2B	4
Phase-Lock-Loop U201	4
Transistor Q201	4
COMPONENT REPLACEMENT	5
INTERCONNECTION DIAGRAM	6
ADJUSTMENT CONTROLS & TEST POINTS	7

INTRODUCTION

This Service Section contains information necessary for aligning and troubleshooting the PCS™ two-way FM Personal Radio. This maintenance manual also provides steps for preventive maintenance, disassembly and procedures for replacing the PA module, chip components and integrated circuit modules.

ADJUSTMENT

Initially, the PCS Personal Radio is aligned and ready for use before leaving the factory. However, if maintenance has been performed the following procedure is intended to be used by a

qualified service technician. (Refer to the Table of Contents above for location of Adjustment Controls and Test Point Diagram.).

Equipment Required:

1. RF Generator (150 - 174 MHz)
2. Wattmeter (5 Watts)
3. Ammeter (2 amperes)
4. Distortion Analyzer
5. Frequency Counter

6. Test Box TQ-0613

7. Test Cable 19B801406P62

TRANSMIT CIRCUIT

Frequency Set: (U203)

1. Set the radio to frequency channel F1.
2. Key the transmit circuit and adjust U203 for the proper customer frequency ± 100 Hertz.

High Power Set: (R119)

1. Set the channel select to the channel programmed for high power.
2. With the transmit circuit keyed, adjust high power set potentiometer R119 to the maximum clockwise position. The power output should be greater than 5 watts.
3. Adjust R119 counterclockwise until the total radio current is 1.8 amperes ± 50 milliamperes. The power output should be greater than 4.5 watts on any frequency in the 150 to 174 MHz band.

Low Power Set: (R11)

1. Set the radio to a channel programmed for low power.
2. Adjust low power set potentiometer R11, located on power control board A101, so that the total radio current is 1.3 amperes ± 50 milliamperes. The output power should be greater than 1.7 watts on any frequency in the 150 to 174 MHz band.

Modulation Set: (R321)

1. Select a channel programmed for Channel Guard operation.
2. With the transmit circuit keyed, apply a 1 kHz tone at 0.5 volts rms to the microphone input.
3. Adjust modulation set potentiometer R321, located on the Audio/Logic Board, until 4.5 kHz ± 100 Hz of deviation is measured.

NOTE

The modulation potentiometer has no limit stop point. All potentiometer values repeat every revolution (4.5 kHz deviation = sum of voice + Channel Guard, modulation).

RECEIVE CIRCUIT

IF Alignment: (L502)

1. Set the radio to Frequency channel F1 and apply a strong carrier at F1.
2. Adjust tuning coil L502 for minimum audio distortion as indicated by a distortion analyzer.

Alternate Method:

1. Apply the proper input frequency modulated with 5 kHz deviation by a 1 kHz tone.
2. Adjust tuning coil L502 for a maximum level as indicated on an A.C. voltmeter connected at J501. Make sure the input level is adjusted for linear operation at J501.

Second Local Oscillator: (L505)

1. Remove all modulation from the input signal and increase the input signal level to 0 dBm.
2. With a frequency counter, monitor the frequency at J501 and adjust tuning coil L505 until 455 kHz ± 100 Hertz is measured.

Quadrature Detector Set: (L506)

1. Apply 3 kHz deviation to the input frequency.
2. Monitor the speaker output from the accessory connector.
3. Adjust tuning coil L506 for a maximum audio level. Load the speaker leads with 16 ohms. Be careful not to ground either lead. Shorts to ground on these leads will damage the radio.

Squelch Adjustment: (R608)

1. Reduce the input signal level to -130 dBm.
2. Adjust tuning control R608, located on the Audio/ Logic Board, clockwise until noise appears at the speaker terminals.
3. Increase the generator level until 12 dB SINAD is observed. **NOTE:** This RF level must be below -119 dBm or the radio will fail the sensitivity specification.
4. Slowly turn R608 clockwise until the audio output disappears.
5. Slowly turn R608 counterclockwise until audio appears.

CAUTION

The squelch adjustment must be made in this sequence only. The squelch potentiometer is continuously variable which causes great confusion if the rotation directions are not followed.

PROGRAMMING

The **PCSTM** Personal Radio is equipped with a 512 X 8 serial personality **EEPROM** which contains all information to tailor the operation of the radio to the user's requirements. Programming of the EEPROM is accomplished using an IBM compatible personal computer with MSDOS, Interface Box 19D438367G1, RS-232 Cable 19B235027P1, Programming Cable TQ-3337 and Programming Software TQ-3329. The programming cable connects to the User Device Connector (UDC) located on the side of the radio.

PREVENTIVE MAINTENANCE

As preventive maintenance to insure that the radio is always operable, regularly schedule the following checks and to be made on each radio.

1. Check condition of and clean electrical connections such as antenna, battery, battery charging contacts and User Device Connector (UDC).
2. Check high and low RF power output.
3. Check Frequency.
4. Check Modulation.
5. Check receiver sensitivity.

DISASSEMBLY PROCEDURE**Tools Needed:**

1. #10 **TORX**[®] Screwdriver
2. Flat Blade Screw Driver
3. 050 Hex Tool

Procedure**To remove the battery pack**

1. Pull the latch toward the battery pack. Wiggle the battery pack from side to side to release it from the wedge in the casting.
2. Loosen the four (4) screws which hold the front and rear radio halves together using a #10 **TORX** screw-driver. These screws are captive in the rear radio half.
3. Pry the front and rear radio halves apart using a flat blade screwdriver or some similar tool.

To Remove The RF Board

1. Remove the friction fit RF shield.
2. Remove the two (2) clips which hold the power module against the casting using a small flat blade screwdriver to pry between the clip and the top of the power module.
3. Remove the five (5) M3-0.5 X 4 TORX screws (#10 drive) securing the RF board to the rear casting.
4. Use a flat blade screwdriver to pry between the casting and the P801 connector housing to lift the RF board out of the casting.

To Remove the BNC Connector

1. Remove #3-48 X .125 long setscrew using a .050 Hex Tool.
2. Remove BNC connector.

To Remove the Audio/Logic Board

Remove the two (2) M3-.05 X 4 and the two (2) M3-0.5 X 10 TORX screws (#10 drive) securing the board to the front radio half.

To Remove the Control Frame

1. Remove the M3-0.50 X 4 TORX screw (#10 drive) securing the control frame to the front radio half.
2. Unsolder the two (2) wires at the speaker.

TROUBLESHOOTING**DOCUMENTATION REQUIRED**

- RX/TX Block Diagram With RF Gains And Levels
- Synthesizer Block Diagram
- Audio/Logic RX Paths Block Diagram
- Audio/Logic TX Path Block Diagram
- Interconnection Diagram
- Outline Diagrams
- Schematic Diagrams
- Parts List
- IC Data

PROBLEMS

Assemblies associated with major problems are as follows:

DISPLAY PROBLEMS

- Audio/Logic Board (Interprets button pushes and issues commands to the display)
- Control Assembly and MOE (Transmission path for commands and houses the driver board and LCD module)

RX AUDIO PROBLEMS

- RF Board (source of audio)
- Audio/Logic Board (Processing of audio)
- Control Assembly and MOE (Transmission path to speaker)
- Speaker (Final output)

TX PROBLEMS

- RF Board (Source of carrier power and audio modulation)
- Audio/Logic Board (Processing of MIC audio)
- Control Assembly and MOE (Transmission path for MIC audio to audio circuits)
- MIC (source of audio)

PROCEDURE**DISPLAY PROBLEMS**

1. Verify Programming.
2. Operate front cap switches and monitor **LCD ENABLE**, **LCD DATA** and **LCD CLOCK**.
3. Check to see if switch signals getting to the audio/ logic board.
4. Check output of U803. Port expander U803 accepts switch closure inputs, and serially communicates with the microprocessor.
5. Check to see if **LCD** signals are being generated by the microprocessor on the audio/logic board.
6. Check to see if **LCD** signals are arriving at the control frame.
7. See if 5 volts is applied to the control frame.
8. Check to see if any switches on the control frame are shorted. If so, no other switch will function because the shorted switch has control of U803.
9. Determine if the radio is in programming mode. Any momentary short on the **MIC HI** line will put the radio in the programming mode. Once in this mode, the microprocessor will ignore any button commands. To get the radio out of this mode turn the radio off and back on again. If a permanent short exists on this line, the radio will return to the programming mode.
10. Check to see if the microprocessor reset signal is proper at power up.

If all of the above checks are OK, the problem is likely on the display module. Remove the module and replace or troubleshoot the module.

The module may be disassembled by releasing the lens tabs located on the bottom of the driver board.

RECEIVE PROBLEMS

- Low or No Audio
- Distorted Audio
- Poor Sensitivity
- Squelch inoperative

1. Check to see if the programming is correct.
2. Check to see if $\overline{\text{CAS}}$ is low.
3. Check to see if the RX mute gates are in the correct states.
4. Check to see if audio is reaching the audio amplifier.
5. Check to see if audio is on the audio amplifier output.
6. Check to see if audio is reaching the speaker.
7. Check to see if the external audio microswitch on the control frame is operated.
8. Check to see if Channel Guard is being used and limited tone data is being generated.
9. Check to see if the data is reaching the microprocessor.
10. If Digital Channel Guard is being used, check to see if the polarity is correct.

After the problem area has been defined, troubleshoot the affected circuit.

RECEIVE RF CIRCUITS

1. Check to see if the spring **J101** is connected to the **BNC** connector center pin.
2. Check to see if 5.4 volts is present.
3. Check to see if d.c. voltages on the rf stages are correct.
4. Check to see if rf gains are correct.
5. Check to see if first and second injection frequencies are correct.
6. Check to see if injection frequency levels are correct.
7. Check to see if the tuning is correct for the crystal filter input.
8. Check to see if the quadrature detector tuning is correct.

The RF Board may be removed from the back casting or placed in a back casting where the rear has been removed to troubleshoot.

SQUELCH CIRCUIT

1. Check to see if there is noise at the high pass filter input when no rf is present.

2. Check to see if filtered noise is present at the high pass filter output.
3. Check to see if the noise level drops when an RF signal is applied.
4. Check to see if the d.c. level at the filtered noise output is variable with rf levels.
5. Check to see if the threshold voltage is present at the comparator input.
6. Check to see if the comparator switches when rf is applied.
7. Check to see if the d.c. level at the threshold terminal increases when the comparator switches.
8. Check to see if the $\overline{\text{CAS}}$ line switching reaches the microprocessor.

RX AUDIO VOICE PATH AND LIMITED DATA PATH

1. Check to see if **VOICE MUTE**, **RX MUTE** and **MUTE** gates are operating. Remember, these lines are controlled by the microprocessor. The **CAS** input along with the **LIMITED TONE DATA** for Channel Guard are the proper microprocessor inputs to cause the mute lines to operate.
2. Check to see if power is applied to the audio amplifier. Remember, the audio amplifier drives a balanced load only. A prolonged short on either speaker (+) or speaker (-) will result in damage to the audio amplifier, speaker or the transistor power switch.

SCAN PROBLEMS

1. With Scan disabled, apply an on-frequency RF signal with proper modulation and Channel Guard to a non-priority channel, and then a P1 channel. Verify that radio is receiving properly.
2. Check squelch opening sinad while not in scan. Disable channel guard while making this measurement. Verify that the squelch opening point lies between 9dB and 13dB sinad. Caution: If squelch opening is set too low, a scanning radio will sometimes think that a carrier exists on a priority channel when none is really present. This will result in poor scanning performance.
3. Enable Scan and continue checking as follows:
 - Monitor the synthesizer enable line with an oscilloscope, and synchronize the scope to the signal.
 - Monitor the volume/squelch high at J801-10 with a second scope probe.

- Monitor CAS signal at J701-5.
- Monitor the output of the Channel Guard low pass filter at top of C636 if scanning for Channel Guard.
- Monitor limited Channel Guard to microprocessor at J701-14.
- Monitor RX audio at J901-13 or -14.

Refer to waveforms shown in audio/logic section and troubleshoot.

TRANSMIT PROBLEMS

- Low or No Power
- Poor Audio Transmitted

The first step when troubleshooting transmit problems in the PCS Personal radio is to check and see if the programming is correct, then identify the defective assembly.

If the problem is rf power related, the likely source is the rf board. However, the **DPTT** and the **BAND SW** lines must be high for proper transmit operation. Check these lines to determine which assembly is defective.

If the problem is modulation related, the most likely problem area is the audio logic board. However, the rf modulation circuit could be the culprit. Monitor the **TX MOD** line to determine if correct audio exist. This will identify the defective assembly.

RF Power Problem

If DPTT and PTT are correct then:

1. Check to see if the RF power module is well ground to the casting wall. **NOTE:** This is the sole ground return for the power module.
2. Check to see that the screws holding the rf board to the casting are tight. If these screws are loose or stripped, oscillations or low power levels may occur. The return path for antenna currents is partially through these connections.
3. Check to see if B+ at the PA pins is present.
4. Check to see if switched 5.4 volts is present at the PA pins.
5. Check to see if there is voltage on the control voltage pin of the PA module.
6. Check to see if the **PIN** diodes are turned On.

7. Check to see if the spring J101 is contacting the center pin of the **BNC** connector.
8. Check to see if VCO drive is present.
9. Check to see if PA module drive is present.

If a drive problem exists, troubleshoot the synthesizer or buffer amplifier. A special synthesizer troubleshooting section follows.

If a switched 5.4 volt problem exists, troubleshoot the 5.4 volt switching section.

If no d.c. control voltage to the PA module exists, troubleshoot the power control module, power set potentiometer and output pass transistor. Remember, the drive signal to the module is the d.c. drop across the coil feeding the PA output stage. The power set potentiometer allows adjustment of a d.c. level to an operational amplifier to set its output voltage. This output level sets the output level on the control line. The Current actually supplied to the PA control pin comes from the power module external pass transistor.

Transmit Audio Problem

If the problem exists on the audio/logic board, then:

1. Check to see if the **MIC** output is reaching the audio /logic board.
2. Check to see if the audio is present at the audio limiter output.
3. Check to see if the $\overline{\text{MIC MUTE}}$ line is in the proper state.
4. Check to see if the audio is at the post limiter filter output.
5. Check to see if the $\overline{\text{PTT}}$ signal is arriving at the microprocessor. This is the command to generate the **DPTT** and **BAND SW** signals along with the **MIC MUTE** signal.
6. Check to see if the audio is at the output of the low frequency boost amplifier.

Find the trouble area and troubleshoot.

If Channel Guard is to be transmitted, then:

1. Check to see if Channel Guard is being generated by the DAC.
2. Check to see if the **TX CG SW** line is allowing the DAC signal to reach the RX low pass filter.

3. Check to see if the RX low pass filter output is being gated to the post limiter filter by the **TX CG** switch.
4. Check to see if the Channel Guard signal is at the output of the post limiter filter.

Troubleshoot the problem area.

If the Audio/Logic Board is OK at the **TX MOD** output, then:

1. Check to see if audio is arriving at the RF board.
2. Check to see if the audio signal is arriving at the operational amplifier on the loop filter module.

If proper audio exists at the loop filter operational amplifier, see the synthesizer troubleshooting section.

SYNTHESIZER

Troubleshooting the synthesizer circuit consists of first checking for the proper d.c. levels. Then determine if proper waveforms are present and check individual modules. When the channel up button on the **PTT** switch is operated, the **SYN ENABLE**, **SYN DATA** and **SYN CLK** should become active. Monitor these lines and troubleshoot the Audio/Logic Board if activity does not occur.

D.C. Analysis

Battery voltage (7.5 Volts, B+) is supplied to a 5.4 volt regulator circuit consisting of transistors Q801, Q802 and Q803. Diode regulator U801 provides a 2.5 volt reference for this circuit. Battery voltage (B+) is also supplied to the loop filter board for isolation amplifier U1. The 5.4 volt regulator supplies both the synthesizer and most of the Transmit and Receive circuits.

The **BAND SW** control input, initiated from the Audio/Logic Board, is used to bandswitch the VCO. This input is low when receiving and high (greater than 3 volts) when transmitting.

Waveforms

Waveforms associated with the synthesizer were measured with a 10 megohm, 30 pf probe. Use d.c. coupling (refer to Figures 1 - 4).

Module Isolation

REFERENCE OSCILLATOR U203

Look on Pin 2 of PLL module U201 for a waveform similar to the one shown for the reference oscillator (Figure 3). If this

waveform is not present, oscillator module U203 is probably defective.

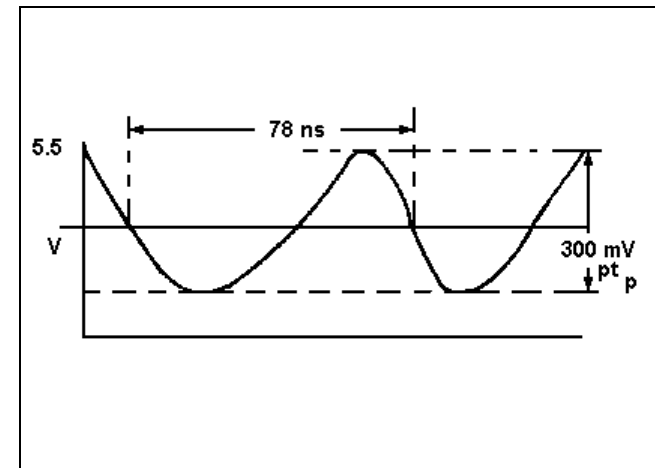

Figure 1 - Reference Oscillator (Input to PLL Module U201, Pin 2)

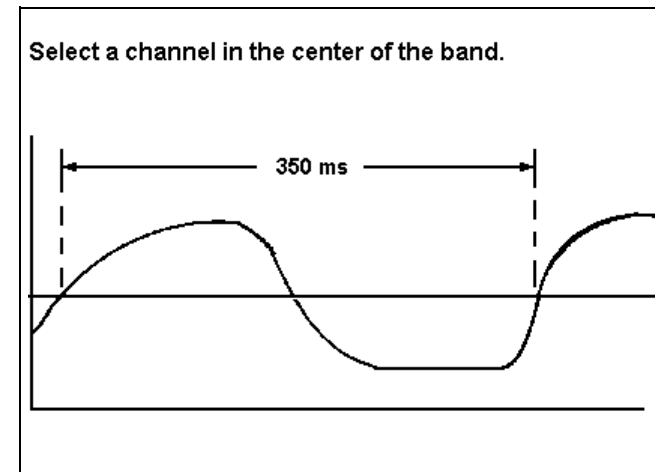

Figure 2 - **F_{in}** (Input to U201, Pin 10)

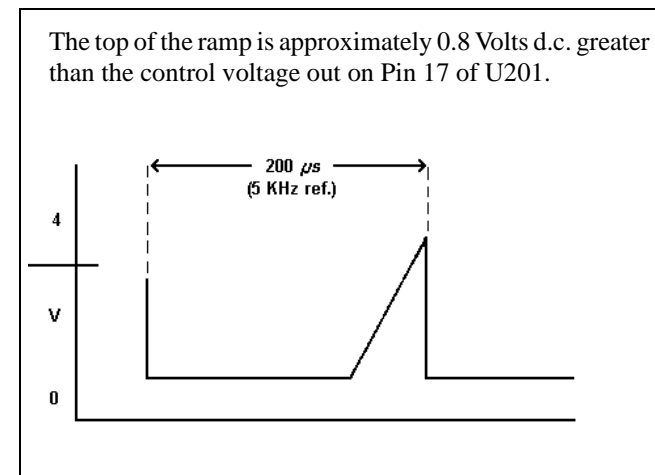

Figure 3 - Ramp (Generated in U201 and appears on Pin 15)

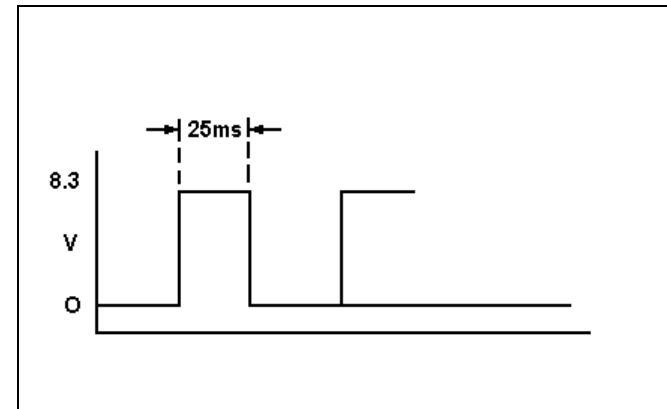

Figure 4 - **SYN EN** (Input to Pin 13 of U201)

VCO U204

Connect a d.c. power supply to Pin 3 of U204. With 2.0 volts d.c. on Pin 3, the output on Pin 5 of U204 should be approximately 190 MHz for the high split. With 4.3 volts d.c. on Pin 3, the output should be approximately 220 MHz.

Power output of the VCO can be measured by connecting a coax cable directly to the module, between Pin 5 and ground, through a 100 pf coupling capacitor. The output should be approximately -4 dBm with capacitor C213 still connected in the circuit.

PRESCALER U202

Connect 4.3 volts d.c. to Pin 3 of VCO U204. With the radio in receive, monitor the frequency of the VCO at Pin 5 through a 100 pf coupling capacitor. Short Pin 1 of U202 to ground to cause divide by 129 to occur. The frequency output at Pin 3 should be the VCO frequency divided by 129. Tie Pin 1 to pin 7 (5 volts) to cause divide by 128 to occur. Check Pin 3 to verify that this occurs. Improper division may indicate a defective prescaler.

BILATERAL SWITCH U2B

Bilateral switch U2B on Loop Filter Board A201 is used to short around parts of the loop filter during channel scan. A shorted gate (to ground or adjacent gate) may be isolated by comparing voltages through the loop filter to those of a functioning radio. Defective gates might be suspected when the radio does not change frequency quickly enough.

PHASE-LOCK-LOOP U201

There are no other specific checks which aid in evaluation of PLL U201. Usually, U201 is suspected to be defective only if all other checks are OK. Before changing, inspect chip components for mechanical damage and check resistances through the loop filter.

TRANSISTOR Q201

After checking for the proper operation, measure the gain from the VCO, Pin 5 to Pin 6 of the Prescaler U202. The gain should be about 0 dB.

COMPONENT REPLACEMENT

PA MODULE REPLACEMENT

To Remove PA Module U101

1. Unsolder the seven leads from U101 using either solder removal braid, or a mechanical de-soldering tool. These leads are fragile and can be bent very easily.
2. Remove the RF Board from the radio chassis assembly. Refer to the Disassembly Procedure listed in the Table of Contents.

REPLACING CHIP COMPONENTS

Replacement of chip capacitors should always be done with a temperature-controlled soldering iron, using a controlled temperature of 700°F (371°C). However, **DO NOT** touch the black metal film of resistors or the ceramic body of capacitors with the soldering iron.

NOTE

The metallized end termination of parts may be touched with the soldering iron without causing damage.

To Remove Chip Components

1. Grip the component with tweezers or needle nose pliers.
2. Alternately heat each end of the chip in rapid succession until solder flows and then remove and discard the chip.
3. Remove excess solder with a vacuum solder extractor or Solder-wick®.
4. Carefully remove the epoxy adhesive and excess flux to prevent damage to the printed circuit board.

To Replace Chip Components

1. Using as little solder as possible, "tin" one end of the component and one of the pads on the printed circuit board.
2. Place the "tinned" end of the component on the "tinned" pad on the board and simultaneously touch the component and

the pad with a well "tinned" soldering iron while pressing the component down on the board.

3. Place the "tinned" soldering iron on the other end of the component and the pad simultaneously. Apply solder to the top of the end of the component until the solder starts to flow. Use as little solder as possible while getting a good joint.
4. After the component has cooled, remove all flux from the component and printed circuit board area with alcohol.

REMOVING INTEGRATED CIRCUITS (IC's)

Removing IC's and all other soldered-in components, can be easily accomplished by using a vacuum de-soldering tool. To remove an IC, heat each pin or lead separately on the solder side of the circuit board and remove the old solder using the de-soldering tool. When all solder has been removed from all pins or leads, remove the IC or component.

CAUTION



The CMOS Integrated Circuit devices used in this equipment can be destroyed by static discharges. Before handling one of these devices, the serviceman should discharge himself by touching power cord connected to an outlet with a known good earth ground. When soldering or de-soldering a CMOS device, the soldering iron should also have a 3-prong power cord connected to an outlet with a known good earth ground. A battery-operated soldering iron may be used in place of the regular soldering iron.

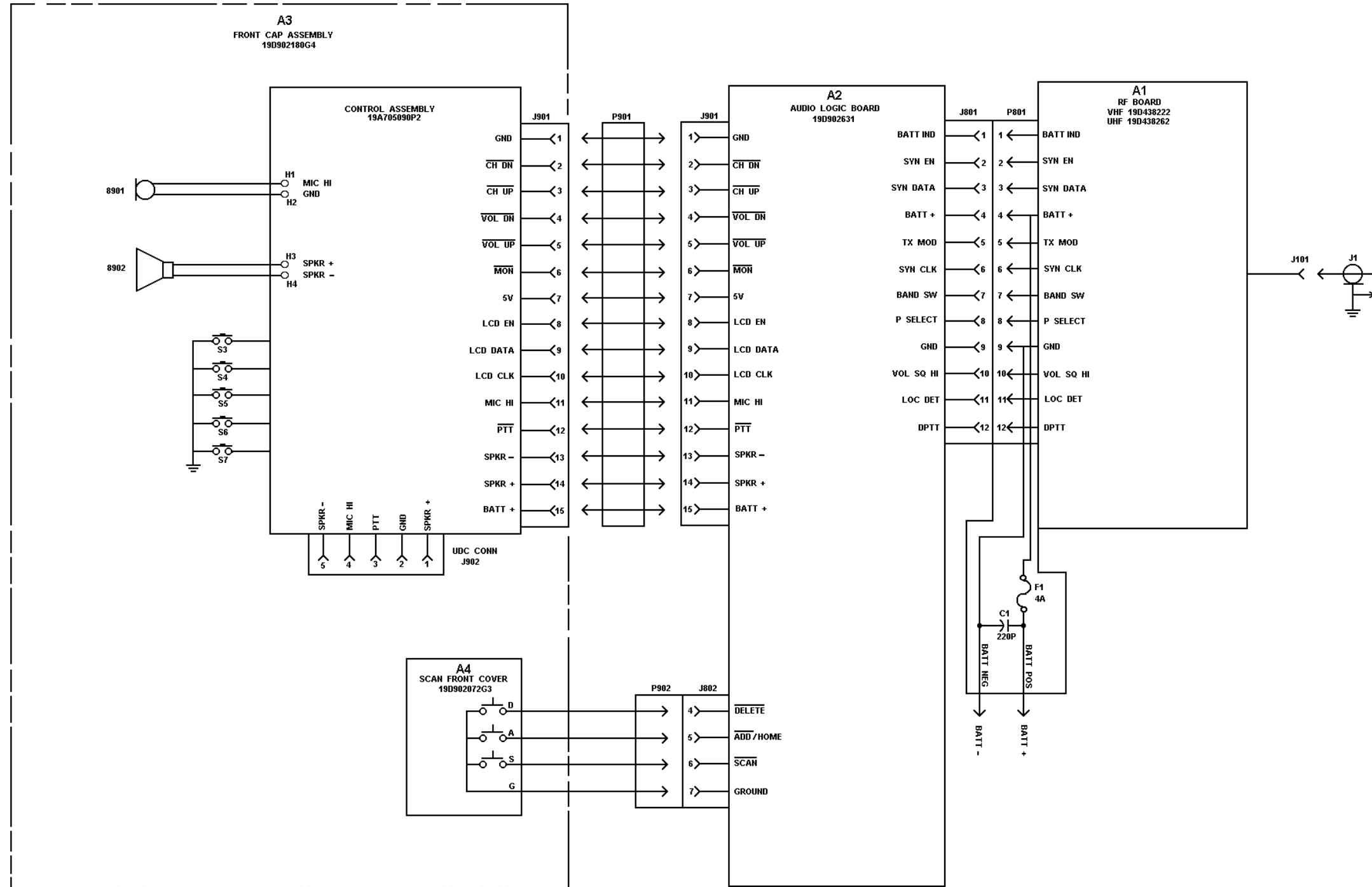

RF BOARD A1
(Component Side)

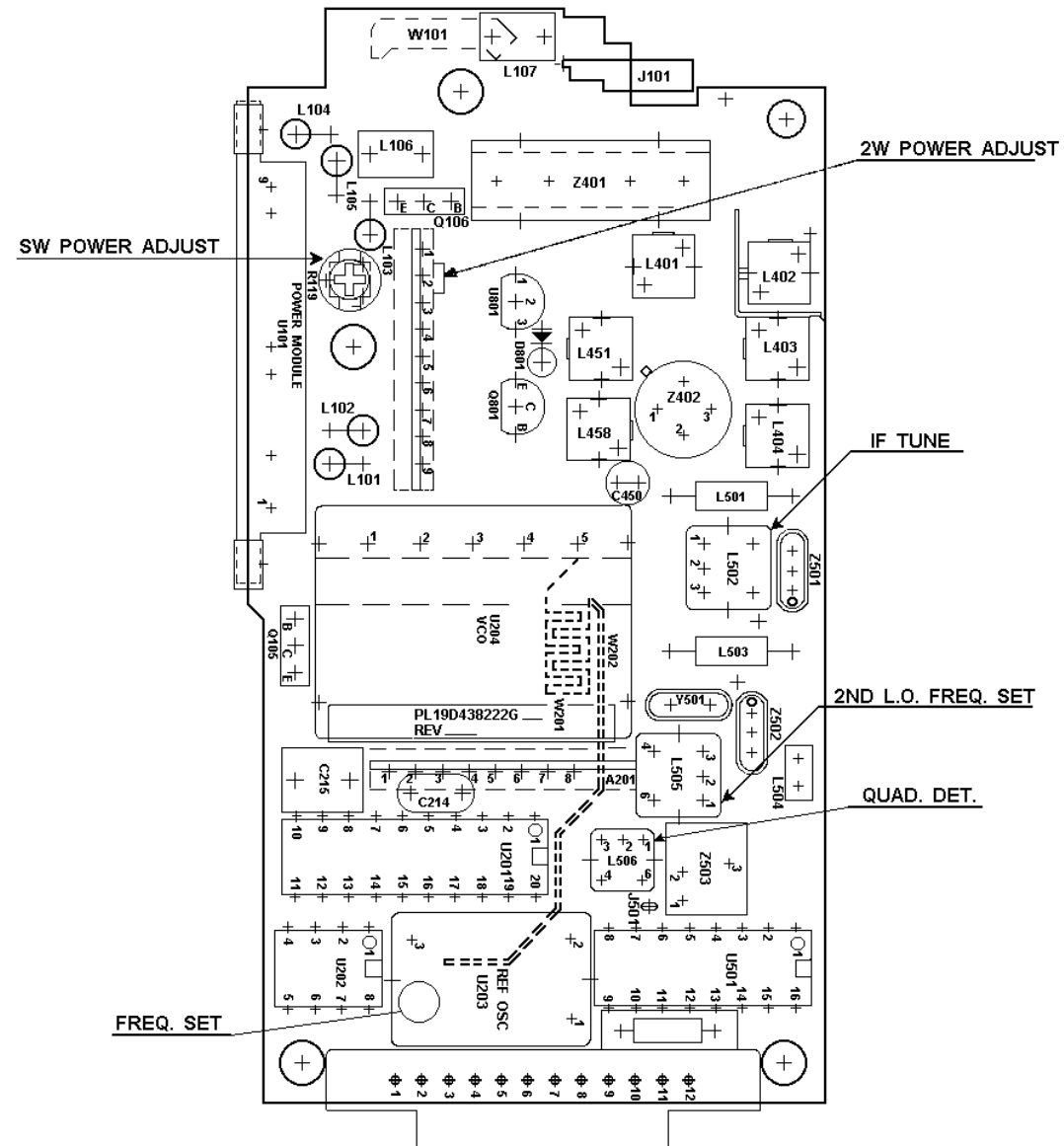

AUDIO/LOGIC BOARD A2
(Chip Component Side)

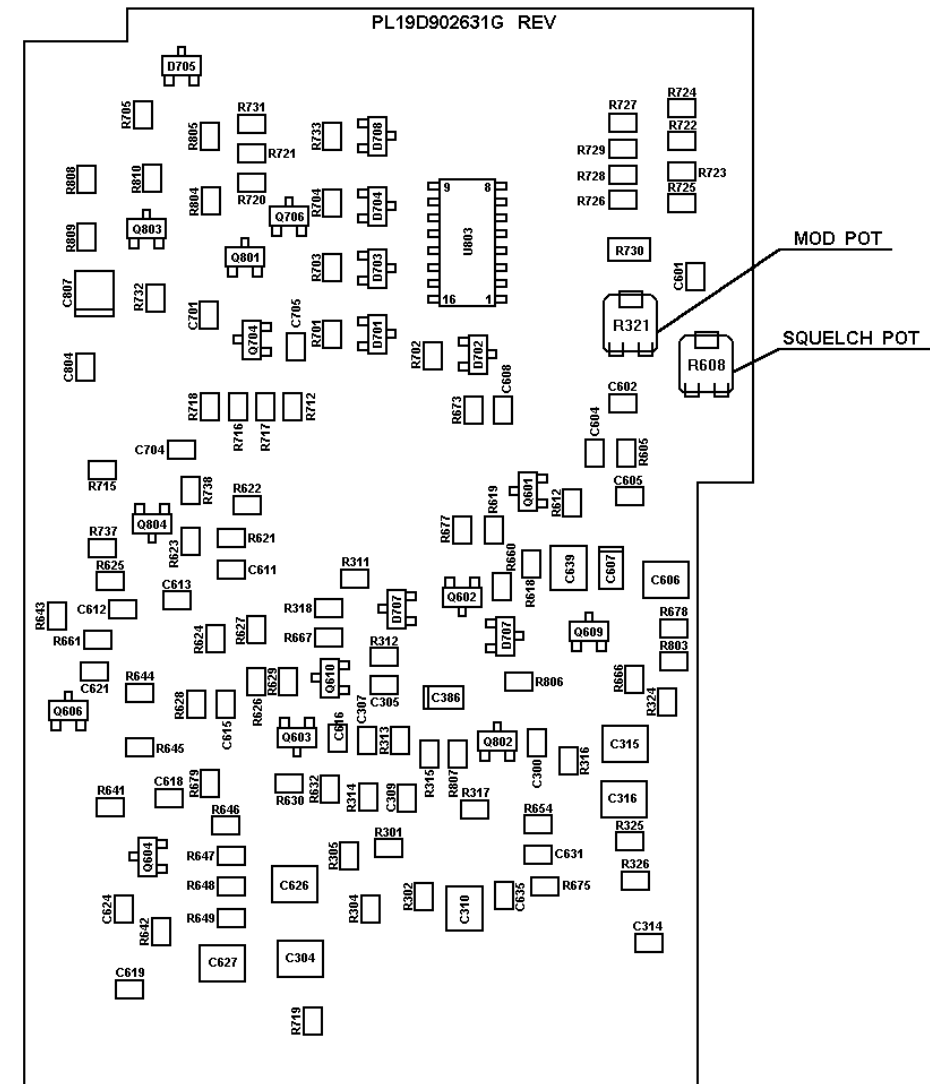

TUNING CONTROLS AND TEST POINTS