



LBI-38636D

Mobile Communications

MASTR[®] III
BASE STATION



Ericsson GE Mobile Communications Inc.
Mountain View Road • Lynchburg, Virginia 24502

Printed in U.S.A.

Installation Manual

TABLE OF CONTENTS

| | <u>Page</u> |
|---|-------------|
| SAFETY SUMMARY | 1 |
| STATION SPECIFICATIONS | 2 |
| PUBLICATIONS INDEX | 3 |
| INTRODUCTION | 4 |
| UNPACKING EQUIPMENT | 4 |
| SITE PREPARATION AND INSTALLATION | 4 |
| CABINET INSTALLATION | 4 |
| Single 37-inch Cabinet | 4 |
| Double Stacked 37-inch Cabinets | 4 |
| ELECTRICAL CONNECTIONS | 5 |
| AC Power | 5 |
| Microphone | 5 |
| Antenna | 5 |
| TELEPHONE LINE SET-UP | 5 |
| Phone Lines | 5 |
| STATION SETUP | 9 |
| SETUP PROCEDURE | 9 |
| ALIGNMENT PROCEDURE | 10 |
| ACCESSORIES | 13 |
| REPEATER PANEL INSTALLATION | 13 |
| CSI MODEL 32 REPEATER PANEL | 13 |
| ZETRON 38A REPEATER PANEL | 13 |
| INTERCONNECTION DIAGRAMS | 14 |
| Figure 1 - Typical MASTR III Stations | 3 |
| Figure 2 - 27-Inch Cabinet | 4 |
| Figure 3 - Single 37-Inch Cabinet | 4 |
| Figure 4 - Stacked 37-Inch Cabinets | 4 |
| Figure 5 - Microphone Connections | 5 |
| Figure 6 - Typical E &M Signalling Applications | 7 |
| Figure 7 - Phone Line Connections | 9 |
| Figure 8 - Antenna Installation | 9 |
| Figure 9 - T\R Shelf Interface Board | 10 |
| Figure 9a - T\R Shelf Interface Board (Rev. A) | 10 |
| Figure 10 - T/R Shelf Connectors | 11 |
| Figure 11 - MASTR III System Modification Pot Alignment | 11 |

SAFETY SUMMARY

The following general safety precautions must be observed during all phases of operation, service, and repair of this product. Failure to comply with these precautions or with specific warnings elsewhere in this manual violates safety standards of design, manufacture, and intended use of the product. Ericsson GE Mobile Communications, Inc. assumes no liability for the customer's failure to comply with these standards.

GROUND THE EQUIPMENT

To minimize shock hazard, the station equipment cabinet must be connected to an electrical ground. The equipment supplied is equipped with a three-conductor AC power cord. The power cord must be plugged into an approved three-contact electrical outlet with the grounding wire firmly connected to an electrical ground (safety ground) at the power outlet. The power cord meets International Commission (IEC) safety standards.

REPLACEMENT OF PLUG-IN CIRCUIT MODULES

Component or module replacement and internal adjustments required must be made by qualified maintenance technicians.

CAUTION

Do not replace components or modules with power supplied.

ELECTROSTATIC DISCHARGE - SENSITIVE COMPONENTS

This station contains CMOS and other circuit components which may be damaged by electrostatic discharge. Proper precaution must be taken when handling circuit modules. As a minimum, grounded wrist straps should be used at all times when handling circuit modules.

DO NOT SUBSTITUTE PARTS OR MODIFY PRODUCT

Because of the danger of introducing additional hazards, do not install substitute parts or perform any unauthorized modifications to the product.

**STATION SPECIFICATIONS
(GENERAL)**

| CABINET | <u>37-INCH</u> | <u>69-INCH</u> |
|----------------------------------|---|-----------------------|
| Height | 37.0 inches | 69.1 inches |
| Width | 21.5 inches | 23.1 inches |
| Depth | 18.25 inches | 21.0 inches |
| Weight (See note 1) | 150 lbs (68 kg) | |
| Rack Units (RU) (See note 2) | | |
| Cabinet capacity | 17 RU | 33 RU |
| Radio | 8 RU | 8 RU |
| Duty Cycle (EIA) (continuous) | Tx and Rx at 100% | |
| Operating Temperature | -30°C to +60°C | |
| Humidity (EIA) | 90% at 50°C | |
| AC Input Power | 5 Amps at 120 Vac (-20%) 60 Hz or 3 Amps at 230 Vac (-15%) 50 Hz | |
| DC Input Power | 33 Amps at 13.8 Vdc (transmit, full power) 25 Amps at 13.8 Vdc (transmit, half power) 1.6 Amps at 13.8 Vdc (receive only, standby) 1.75 Amps at 13.8 Vdc (receive only, 1 watt at service speaker) | |
| Service Speaker | 1 watt at 8 ohms | |
| Service Microphone | Dynamic | |

Notes:

1. Typical station consists of:
 - a. One T/R Shelf with plug-in modules.
 - b. One Power Amplifier.
 - c. One power supply unit.
 - d. One cabinet with doors.
2. One rack unit equals 1.75 inches.

**STATION SPECIFICATIONS
(INTERFACE)**

| | |
|----------------------------------|---|
| Line Interface | |
| Line Interface | 2-wire or 4-wire (programmable) |
| Line Cancellation (2-wire) | 20 dB amplitude only (programmable) |
| Line Input (line to transmitter) | |
| Line Terminating Impedance | 600 ohms (2-wire or 4-wire) |
| Line Input Level (adjustable) | -20 dBm to +11 dBm |
| Frequency Response | 300 Hz to 3000 Hz |
| Line Input(receiver to line) | |
| Line Terminating Impedance | 600 ohms (2-wire or 4-wire) |
| Line Output Level (adjustable) | zero output to +11 dBm (ref at 1 kHz) |
| Frequency Response | 300 Hz to 3000 Hz, ±1 dB |
| Remote Control (Tone) | |
| Control Tones (Hz) | 1050, 1150, 1250, 1350, 1450, 1550, 1650, 1750, 1850, 1950, 2050, & 2175 |
| Secur-it | 2175 Hz |
| Function | Programmable |
| Hold | 2175 Hz |
| DC Remote Control | |
| Control currents | -2.5 mA, ±6.0 mA, ±11.0 mA |

PUBLICATIONS INDEX

| | |
|--|-----------|
| MASTR III BASE STATION Systems Combination Package | LBI-38775 |
| T/R Shelf | LBI-38637 |
| System Module | LBI-38764 |
| Power Module | LBI-38752 |
| MASTR III PC Programmer | TQ-3353 |
| MASTR III Installation Manual | LBI-38636 |
| RF Module Test Fixture | LBI-38805 |
| MASTR III Utility Handset | LBI-38599 |
| RF Package: High Band (150.8 - 174 MHz) | LBI-38754 |
| Transmit Synthesizer Module | LBI-38640 |
| Receive Synthesizer Module | LBI-38641 |
| Receiver Front End Module | LBI-38642 |
| IF Module | LBI-38643 |
| Power Amplifier | LBI-38531 |
| Duplexer | LBI-38763 |
| RF Package: UHF (450 - 470 MHz) | LBI-38675 |
| Transmit Synthesizer Module | LBI-38671 |
| Receive Synthesizer Module | LBI-38672 |
| Receiver Front End Module | LBI-38673 |
| IF Module | LBI-38643 |
| Power Amplifier | LBI-38674 |
| Duplexer | LBI-38763 |
| Power Supply | LBI-38550 |
| Emergency Power (Battery Charger) | LBI-38625 |
| Auxiliary Receiver | TBD |
| Voice Guard System Manual | LBI-31600 |
| Voice Guard Station Shelf | LBI-31532 |
| Voice Guard (Encrypt/Decrypt) | LBI-31682 |

NOTE: Indented maintenance manuals are included with the header (cover) maintenance manual.

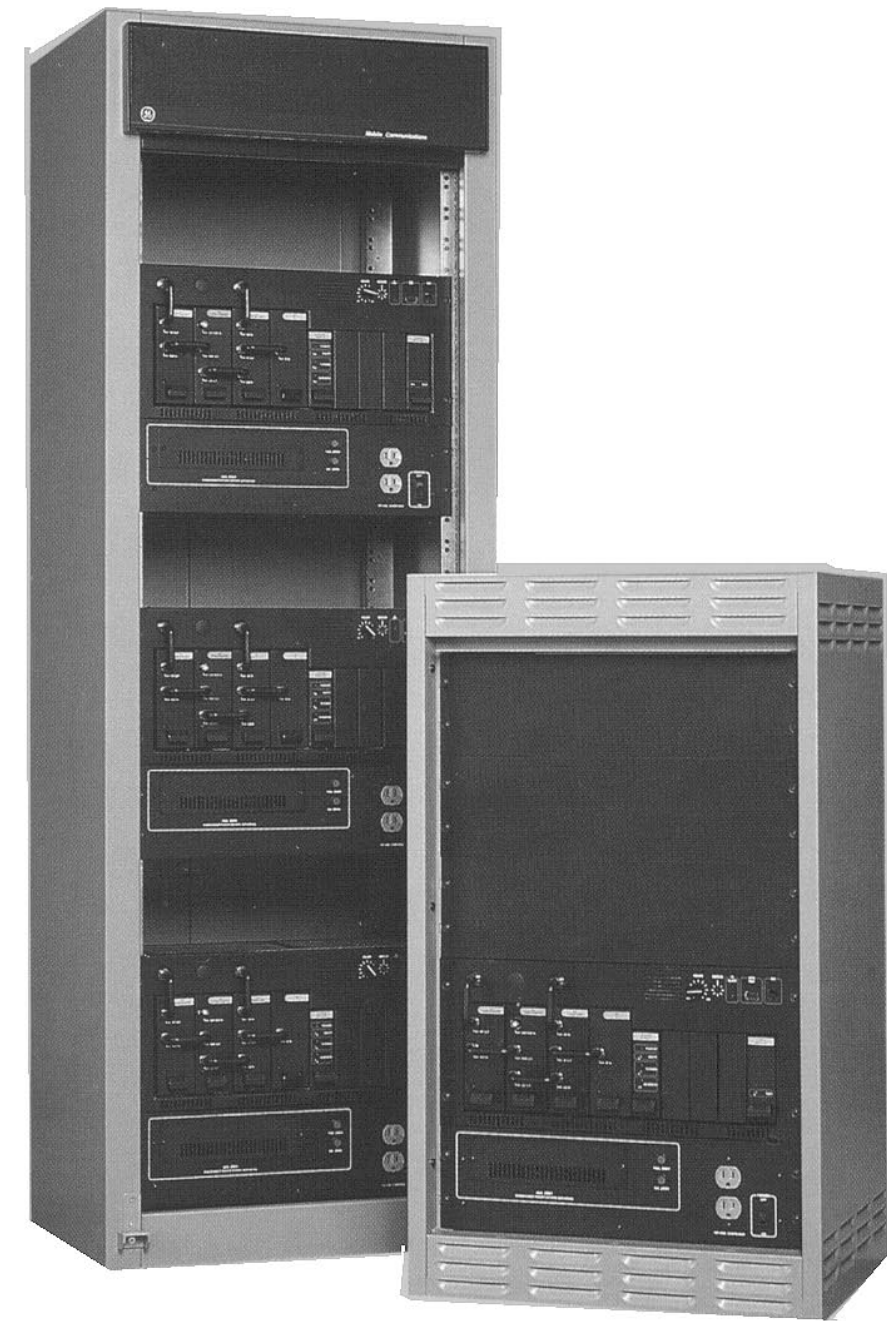

Figure 1 - Typical 37-Inch And 69-Inch MASTR™ III Stations

INTRODUCTION

This manual describes the installation and connections for a typical MASTR III station combination. Information provided includes suggested locations and installation of equipment and hardware, interconnection and assembly diagrams, alignment instructions, and troubleshooting suggestions.

The MASTR III cabinet normally includes the Transmitter/Receiver Shelf, the Transmitter Power Amplifier, and a Station Power Supply. The assemblies are mounted in a 37-inch cabinet. Optional 69-inch or two stacked 37-inch cabinets are available.

Cabinet

The system is contained in a 37-inch cabinet with improved ventilation for greater reliability. The cabinet can also house optional equipment such as a Duplexer, Charger, Gell Cell batteries, or Auxiliary Receiver.

Station Power Supply

The Station Power Supply provides all necessary power to run the station. It provides 13.2 volts at 33 amps to the station from an AC source. The source voltage depends on the particular area and power sources available. The power supply is normally mounted beneath the T/R Shelf.

Transmitter/Receiver Shelf

The MASTR III Transmitter/Receiver (T/R) Shelf contains the station control electronics for dc/tone remote, remote/repeater, or repeater only applications. The station control electronics consists of a Backplane board, Power Module, System Module, and an Interface Board. The backplane also connects the RF Section which consists of the Receiver Synthesizer Module, First IF Module, Second IF Module, and the Transmit Synthesizer Module.

Transmitter Power Amplifier

The Transmitter Power Amplifier is mounted directly behind the the T/R Shelf. Cabling from the output of Power Amplifier will depend on the system configuration.

UNPACKING EQUIPMENT

Unpack the station and carefully inspect each item. If any damage has occurred to the equipment during shipment, immediately file a claim with the freight carrier. AC power adequate to meet system requirements, environmental control, and digital or voice grade phone lines must be available at the site prior to installation.

SITE PREPARATION AND INSTALLATION

CABINET INSTALLATION

The MASTR III station cabinet is designed for servicing from the front. However, the system may also be serviced from the rear when adequate space is available. The cabinet should be mounted on a level, solid surface.

If rear servicing is desired, cabinets should be setup with a minimum of 24-inches of clearance in the rear and between cabinets or wall to permit ventilation and room for the serviceman to move between and behind the cabinets.

If space is at a premium or if servicing is to be made from the front only, then cabinets should be setup with a minimum of 18-inches of clearance in the rear and 12-inches between cabinets to permit ventilation. However, access to the rear of the cabinets may still be necessary in order to install or repair antenna or power cables.

Single and double stacked 37-inch cabinets must be securely anchored to the floor according to the footprint shown in Figure 2 and following single or double stacked installation instructions.

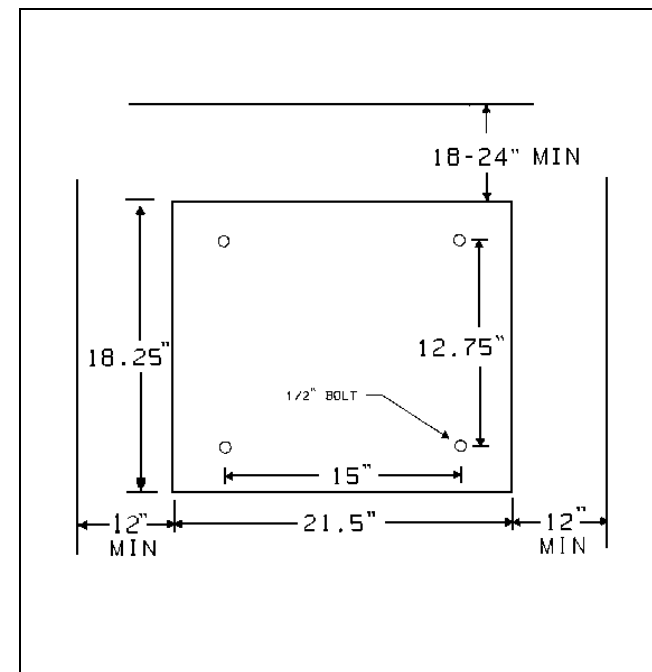

Figure 2 - 37 Inch Cabinet Mounting Footprint

Single 37-inch Cabinet installation

The station provides for front and rear door servicing or front door only servicing in tight space situations. The front and rear of the station must be kept clear of obstructions so that the serviceman can easily remove the front and rear doors for servicing. Also, the front and rear air vent louvers and rear cable outlets must be free of obstructions.

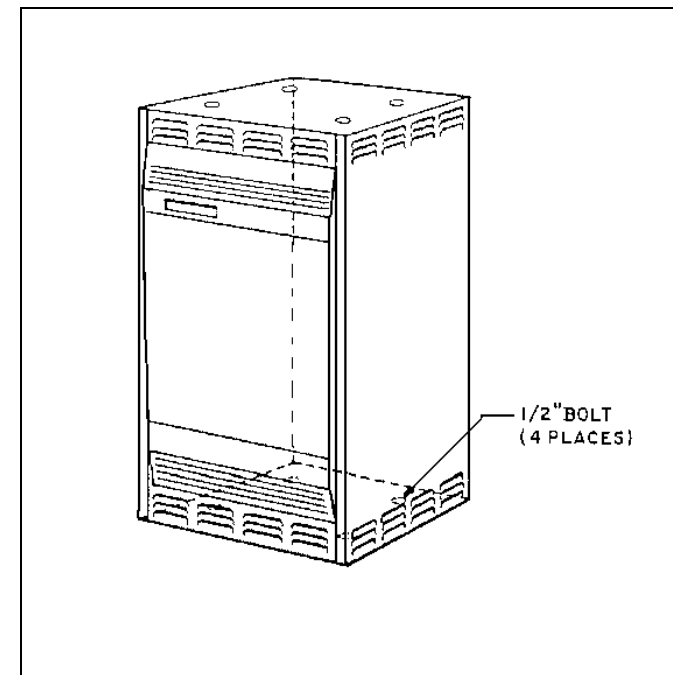

Figure 3 - 37-Inch Cabinet

Using the four holes are provided in the bottom surface of the cabinet, the cabinet must be securely bolted to the floor with 1/2" bolts and anchors as shown in Figures 2 and 3. It will be necessary to remove the front and rear door covers and some internal components to allow access to the bottom securing holes.

Double Stacked 37-inch Cabinet installation

For limited floor space situations, two 37-inch MASTR III cabinets may be stacked one upon the other. This requires that the bottom cabinet be securely bolted to the floor surface and the top cabinet securely bolted to the top surface of the bottom cabinet, as shown in Figure 4.

Ensure first that the floor is strong enough to support the weight of the two cabinet configuration and that adequate ceiling height is available. Ensure the front and rear of the station cabinets are clear of obstructions so serviceman can easily remove the front and rear doors for servicing. Also, the front and rear air louvers and rear cable outlets must be free of obstructions. Leave a minimum of 12-inches of space on each side of the cabinets to avoid obstructing the louver air vents.

With the bottom cabinet in position, secure it to the floor as shown in Figure 2 with 1/2 inch bolts and anchors. Remove the four plastic plugs in the top surface of the bottom cabinet (by squeezing the plastic retaining barbs together from the inside of the cabinet and pushing the plug up and out).

Position the top cabinet on the bottom cabinet. Align the fixing holes and bolt the cabinets securely together using 1/2 inch bolts, washers, and locknuts (supplied in hardware kit 344A3450G7) as shown in Figure 4.

It will be necessary to remove the front and rear covers and some internal components to allow access to the top and bottom securing holes.

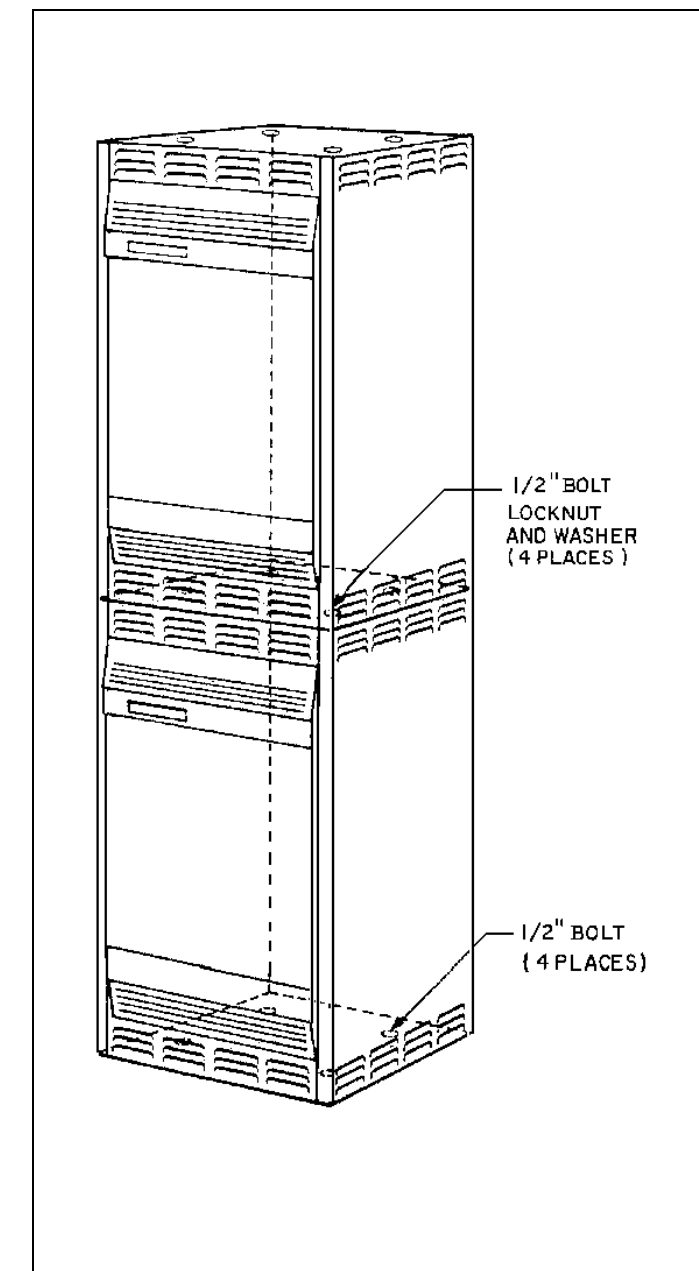

Figure 4 - Stacked 37-Inch Cabinets

ELECTRICAL CONNECTIONS

AC Power

The station will be received with the power cord bundled and stored in the bottom of the cabinet. Remove the twist tie from the AC power cord, unravel and feed the cord through one of the rear cable holes. It may be helpful to remove the grommet from the hole before passing the cord through and reinstalling it afterwards.

A separate 15 to 20 Ampere, 120 Vac, 60 Hertz electrical circuit should be provided for the station. A 120 volt grounded AC outlet for the station should be located within six feet of the lower rear of the cabinet. The power cord for the 120 Vac Power Supply comes with a grounded 120 Vac molded plug attached. Check the electrical code to ensure the power outlet complies with local ordinances.

If a 240 Vac, 60 Hz source is used for the station, an external step-down transformer (similar to 19C307148P1) must be used.

For 230 Vac, 50 Hz applications, the station power supply is equipped with a power cord, less connector, to permit connection to an acceptable electric circuit. A plug meeting local electrical codes must be supplied by the customer. Make sure the station power supply is connected to an outlet having the same configuration as the plug. No adapters should be used in this configuration.

The equipment should be connected to a good earth ground using a ground wire of adequate size. A ground stud is provided for a separate cabinet ground. Use No. 14 or larger wire (depending on local ordinances and system requirements) for connecting the cabinet to a good building ground. After the ground lead from the power cable is connected to the building ground, check for continuity between building ground and the cabinet.

Microphone

The local microphone or utility handset may be attached to the station through the MIC port on the front of the T/R Shelf (see Figure 9), the connections are shown in Figure 5.

Antenna

The antenna cable may be routed through the top rear or bottom rear of the cabinet directly to the appropriate connector within the station, depending upon the configuration.

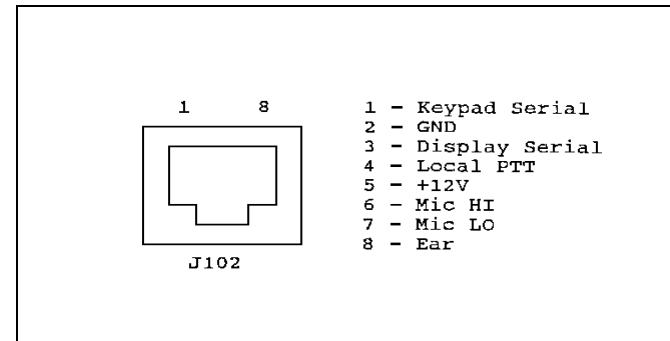

Figure 5 - Microphone Connections

TELEPHONE LINE CHARACTERISTICS

Phone Lines

The type of telephone lines required for the installation will depend on how the station is controlled and if it is being used for simplex or duplex operation. Generally, both 4-wire Audio and E & M Signalling options are used to interface between the radio and carrier systems. However, 2-wire Audio can be used in the two-way radio portion of the control system if hybrids are installed to provide transition between the 2-wire and 4-wire connections. Usually the E & M Signaling is separated from the audio (separate line) in both 2-wire and 4-wire installations.

Types Of Voice Grade Lines

Telephone lines are normally obtained from a communications common carrier ("**phone company**" for our purposes here). When a voice grade (as contrasted to a "**data line**") telephone line is requested, there is no way of knowing just what type of line will be received from the phone company.

In addition, the telephone company may supply one type of line first, and later change it to another type without any notification to the user. One of the following types of telephone line can be expected:

1. Wire lines with no amplifiers
2. Wire lines with amplifiers added to compensate for line loss
3. Facilities derived from carrier (multiplex)

These lines have different operating characteristics, and each must be treated differently. In large systems, all three types of lines can be provided. In long haul applications, a system can consist of two or three of these types of lines in tandem (tied together end-to-end).

The first type is **WIRE LINE WITH NO AMPLIFIERS**. These are the same lines that have been used for years to control dc systems. These are the easiest to work with since they include no problem-causing electronic equipment. These lines are normally found in less populated areas where the phone company has not yet switched to carrier systems.

These lines have a fixed amount of loss which varies with frequency, temperature, from deterioration of splices, and from moisture getting into the cables. When these cables get old, the phone company sometimes applies DC current to improve the joints and lower the line loss. In this case, the line is not usable for DC control.

Normally, a +10 dBm test tone can be applied to these lines. These lines do not normally include any type of voice limiters.

The second type of line is a **WIRE LINE WITH AMPLIFIERS**. These lines are normally supplied when the loss of available lines is too high. An amplifier or several amplifiers are added to the line to make up for the loss.

One commonly used amplifier is the E-6 repeater. This amplifier will pass DC current and they have been used on DC lines for years. These amplifiers include limiters which start limiting at somewhere around 0 dBm input to the amplifier. The limiters do not cause any real problems on DC systems since only the voice peaks are clipped. However, special care must be used when applying them to tone remote control systems.

Each amplifier can be adjusted for up to 12 dB of gain. If the loss is more than 12 dB, one or more amplifiers may be added. The amplifier(s) can be placed at any point in the line.

The third type of telephone line is a **Derived Facility** using carrier equipment. Since this is the most complicated, more care is required when connecting radio equipment. This type of line will be available more often in the future.

The phone company supplies two wires at each end of the circuit. Each two-wire end goes to some point in the circuit where it is converted to a four-wire circuit and then connected to the carrier equipment. A four-wire circuit can be ordered if that is what is required. At the other end, it is taken out of the carrier equipment and converted back to the two-wire circuit. The carrier equipment has a transmit path and a receive path. The gain is adjustable each way.

The phone company wants to see a maximum three-second level of -13 dBm at the carrier equipment as measured on a modified Western Electric 3-type Noise Measuring Set. The telephone equipment will limit the audio if the signal is above -13 dBm at the carrier input. This does not mean that the maximum that can be applied into the two wire end is -13 dBm. If the radio equipment is a good distance from the carrier equipment, there will be some line loss. If the loss is

5 dB, for instance, then -8 dBm could be applied into the two wire end. Therefore, the phone company will have to be asked in each case what level is allowed to be applied at the two-wire end.

If the phone company checks and finds that too much audio is being applied into the carrier equipment, they will put a pad into the circuit to cut the audio down.

When the phone company is asked what levels can be applied to the line, they will either provide a **Volume Units (VU)** or test tone. **VU** is average voice which is generally considered to be 10 dB below test tone. Test tone is a 1000 or 1004 Hz tone used to line up the circuit. Test tone is normally given in dBm. If the radio installer isn't careful, he and the phone company will be talking 10 dB apart. If the phone company says the limit is 0 VU, use +10 dBm for the line-up.

The two wire ends of these lines are normally designed to work with a 600 ohm impedance in and out. The transmit and receive carrier equipment gains are set up for 600 ohm terminations. If the line to the carrier equipment is fairly long, the impedance at which at the two-wire end is not very critical.

If the two-wire end is close to the carrier equipment, however, then the impedance is critical. If the impedance is not 600 ohms, it can cause the gain of the carrier equipment to go up or down. In some cases, feedback (oscillations) from the receive path to the transmit path will be present. A common problem which causes oscillations in the carrier equipment is gain change, whether from misalignment or other reasons.

American Telephone and Telegraph Company has published a reference for Voice Grade Lines entitled, "**Private Line Interconnections, Voice Applications**" (Publication Number 43201). It covers several types of private line interfaces. There is no publication that covers radio control alone. However, there are several parameters provided in the publication that are important to note.

The 1000 Hz loss design objective is 0 to 10 dB. If the loss is not specified, there will be a loss of 10 dB at 1000 Hz in most cases. The phone company allows itself a **SHORT-TERM** fluctuation of 3 dB and a **LONG-TERM** variation of 4 dB. If a 10 dB loss line at 1000 Hz is specified, up to 14 dB loss can be expected, and the phone company would still be within their design limits.

The loss between 500 and 2500 Hz can be +2 dB and -8 dB relative to 1000 Hz loss. Note that the phone man may refer to this as -2 and +8 in the telephone company way of talking. The loss between 300 and 3000 Hz can be +3 dB to -12 dB relative to the 1000 Hz loss. This says that if there is a line with 10 dB of loss at 1000 Hz, a loss of as much as 18 dB at 2500 Hz, and 22 dB of loss at 3000 Hz can be expected. A loss 4 dB of long-term variation should be added to this.

Noise on this type of line is measured at each end with a Western Electric 3-type Noise Meter. The allowable level of a line from 0 to 50 miles is 31 dBrnC, and for a line from 51 to 100 miles is 34 dBrnC. If this type meter is not available, an AC- VTVM can be used. If there is a noise reading of -50 dBm or less, generally this is considered an acceptable circuit.

Tone Remote Control Systems

In contrast with DC systems, where audio level setting is not as critical, it is important that levels in tone applications be set properly. Failure to do so results in the control function not working properly. For example, after the installation when the user has gained a little experience, the user may find that they are not always picking up the function selected. A little extra time spent at the installation will save many problems of this type later.

This equipment is designed so that the tone sequence consists of either two or three parts. The first part is the "Secur-it" tone (2175 Hz) which is sent at the highest level for approximately 125 milliseconds. This is followed by the "Function" tone which is sent at a level 10 dB lower for approximately 40 ms. In the case of a transmit function, the "Function" tone is followed by 2175 Hz "Hold" tone at a level 30 dB down from the "Secur-it" tone burst (therefore, it is 20 dB down from the "Function" tone burst). This tone continues for the duration of the transmit function. The average voice (0 VU) is sent at the same level as the "Function" tone, therefore, the test tone for the voice is sent at the same level as the "Secur-it" tone.

The "Secur-it" tone must arrive at the base station at no less than -20 dBm. The transmit "Hold" tone must arrive at the base station at no less than -50 dBm. The test tone for the voice must arrive at the base station at no less than -20 dBm. Therefore, the limits of system operation are usually established by only three things:

1. The maximum level at 2175 Hz that the phone company will allow to be sent from the most distant point in the system. Normally this will not be higher than 0 dBm. In some cases it can even be less, or on rare occasions it can be +5 or +10 dBm.
2. The loss of the circuit at 2175 Hz. Do not forget the long-term variation of up to 4 dB more.
3. The requirement that the "Secur-it" burst must arrive at the base station at no less than -20 dBm.

Normally, most systems will not crowd these limits. However, if the result is a few dB short, consider adding C-1 conditioning (at an added cost). Resist the natural desire to just turn up the tone sending level as this will cause improper system operation.

Increasing the level will cause the "Secur-it" tone burst to go into limiting in the phone company equipment. The limited tone causes the "Secur-it" tone filter in the base station to ring. This will result in picking up or dropping out functions which were not selected. **NEVER** allow the "Secur-it" tone to be in limiting.

There is an easy way to check and see if the "Secur-it" tone is in limiting. With the phone lines connected to the equipment at both ends connect an AC voltmeter across the phone line at the base station. Arrange to send a burst of "Secur-it" tone long enough to measure the incoming level on the AC voltmeter. Then arrange to send a burst of 1950 Hz "Function" tone long enough to measure the incoming level on the AC voltmeter. If the 1950 Hz tone does not arrive 10 dB (1 dB) less than the "Secur-it" tone, then the "Secur-it" tone is in limiting. It will become necessary to lower the sending level at the remote controller until it is below limiting.

If the audio is high enough to cause the telephone equipment to go into limiting, it will cause amplitude distortion. On a high loss line the amplitude distortion will cause the "Hold" tone (2175 Hz) to vary and the transmitter to drop out.

On remote systems using tone control, care must be used when connecting two telephone lines in tandem. For example, for a base station and two remotes, a phone line is ordered to connect the station to the first remote, and a second line to connect the second remote to the first remote. The loss of each line is now added together and the tones from the second remote can not operate the base station. The installer can either specify a low loss on each line, or run each line directly to the base station.

A check with the phone company can determine which approach is the least expensive over a period of time; i. e., an analysis of non-recurring costs versus recurring costs over the expected length of time the circuit will be used.

Voting System Considerations

A voting system uses a continuous 1950 Hz tone on the telephone line when the receiver is squelched. This voting tone is normally sent from the station to the voting selector 3 dB lower than the 1000 Hz test tone level. Most telephone lines have a frequency response which attenuates the 1950 Hz tone with respect to a 1000 Hz test tone, therefore care should be taken to ensure that the correct levels are received at the voting selector.

If the phone company will not allow a continuous tone as high as -8 dBm to be sent, then a lower loss circuit should be requested or C-1 conditioning added.

When ordering phone lines for a voting system, if possible, all lines should be of the same type. Different phone line responses will cause the voter to prefer one signal over others.

It is improper system design to have the received signal selection biased by a "poorer" telephone circuit. Many phone companies will add pads to build out the lines. If this is considered when the lines are ordered, it should not be difficult to build all of the lines out to have the same frequency response.

Ordering Voice Grade Phone Lines

If a standard voice grade circuit is ordered, and the loss is not specified, the following will normally result:

1. Loss at 1000 Hz will be 5 to 10 dB; normally 10 dB
2. Long-term variation 4 dB
3. Amplitude distortion (frequency response)
Referenced to 1000 Hz; + = more loss
300 to 3000 Hz: -3 to +12 dB
500 to 2500 Hz: -2 to +8 dB
4. Noise: 31 dBrnC maximum
5. Frequency translation error: 5 Hz
6. Normal impedance: 600 ohms
7. Maximum permitted signal into the line:
-6 dBm to -13 dBm in-band three second average (the level arriving at the carrier equipment cannot be more than -13 dBm)

By adding C-1 conditioning, the loss changes to:
Amplitude distortion (frequency response)
Referenced to 1000 Hz; higher frequency = more loss
300 to 2700 Hz: -2 to +6 dB
1000 to 2400 Hz: -1 to +3 dB

One added advantage to C-1 conditioning is that the voice quality will be improved by boosting the high frequency components.

Phone Company Ordering Information

When ordering a telephone line, the following must be considered:

1. Type of circuit:

Voice grade, 2-wire termination, for radio control, and tone remote system - send/ receive; voting system - receive only.

2. DC continuity not required
3. Impedance: 600 ohms 20%
4. Line Loss:

Tone remote system:

Sends 2175 Hz tone for 125 milliseconds, and it must arrive at the base station at no less than -20 dBm including long-term variation. Average voice is 10 dB below the 2175 Hz tone burst.

Voting system:

Sends a continuous 1950 Hz tone when the receiver is squelched, and it must arrive at the voting selector at no less than -30 dBm including the long-term variation.

5. C-1 conditioning if necessary. (If two phone lines are to be tied in tandem, it is usually proper to specify C-1 conditioning.)
6. If more than one phone line is to be used, a block diagram showing locations and type of equipment to be used should be provided the telephone company.

PHONE LINE INSTALLATION

Two-Wire Operation

For two-wire operation, connect the pair to TB101-3 and -4. If the remote control unit at the other end is an RCN 1000, use J3-3 (red) and -4 (green). Refer to Methods 1 and 2 in Table 5 and associated illustration for examples. Jumpers should be placed on P104-1 to P104-2 and P105-1 to P105-2 on the Interface Board. Figure 7 shows the location of Interface Board connectors and jumpers.

NOTE

Polarity must be maintained if the metallic control pair is being used for DC control.

Four-Wire Operation

For examples, refer to Methods 3 and 4 in Table 5, and the associated illustrations showing the different methods. Jumpers should be installed on P104-1 to P104-3 and P105-2 to P105-3 on the Interface Board.

E & M Signalling

E & M lead signalling systems derive their name from certain historical designations of the signalling leads on circuit drawings. An "M" lead is associated with the transmit function while the "E" lead is associated with the receive function. In two-way radio systems with remote control, E & M Signalling can be the only type of control offered by the available carrier circuits.

Generally, both 4-Wire Audio and E & M Signalling options are used to interface between the radio and carrier systems. However, 2-Wire Audio can be used in the two-way radio portion of the control system if hybrids are installed to provide transition between the 2-Wire and 4-Wire connections. Usually the E & M Signalling is separated from the audio (separate line) in both 2-Wire and 4-Wire installations.

Figure 6 illustrates a typical interface between a two-way radio system and a multiplex/microwave system. The Remote Control Console and Base Station are equipped with the E & M Signalling Option and the 4-Wire Audio Option. The console provides a regulated -48 Vdc output (or -24 Vdc with minor modifications) to the "M" lead when the TRANSMIT switch is pressed. This -48 Vdc activates a tone encoder (usually 3825 Hz) in the multiplex rack. The tone encoder modulates the carrier frequency which is transmitted over the microwave link.

At the station end of the microwave link, the signal is demodulated and the 3825 Hz tone operates a tone decoder in the multiplex rack. The output of the decoder results in a contact closure which applies +48 Vdc (or +24 Vdc) to the control shelf. This voltage should be connected between TB101-1 and TB101-6 on the Interface board. Jumpers on P104 and P105 of the Interface Board should also be removed.

Table 5 - Wire Line Installation Methods

| METHOD | DESCRIPTION | PROCEDURE | ADVANTAGES OR DISADVANTAGES |
|--------|---|--|--|
| 1 | Single metallic pair (the control currents are simplex to line, a two wire cable is required). | a. Connect the metallic pair to TB101-3 and -4. b. Jumper P105-1 to P105-2, and P104-1 to P104-2 on the Interface Board. | Economical: Dependable where earth ground currents may be large or good earth grounds cannot be obtained. The keying clicks will be heard on parallel remotes. |
| 2 | Single metallic pair (the control currents are simplex to line to earth ground, a two wire cable is required). | a. Connect the metallic pair to TB101-3 and -4. b. Jumper P105-1 to P105-2 to P104-1 on the Interface Board and connect TB101-6 to earth ground. | Economical: Minimizes keying clicks in paralleled remotes but large ground currents may result in interference with control function if located near sub-stations. |
| 3 | One voice grade circuit for bi-directional audio and the other a metallic pair of control voltages. | a. Connect audio pair to TB101-3 and TB101-4. b. Remove jumpers from P104 and P105 on Interface Board. c. Connect control metallic pair to TB101-1 and -6 on Interface Board. | Provides excellent performance by eliminating keying clicks and providing no path for ground loop current, but requires two pair. |
| 4 | Single metallic pair for transmit audio and control currents. Single voice grade circuit for receive audio. A four wire line is required. | a. Connect the transmit metallic pair to TB101-2 and -5 on Interface Board. b. Connect a jumper from P104-1 to P104-2, and P105-1 to P105-2. c. Connect the remote receive pair to TB101-3 and -4. | Provides full duplex operation in which the remote can operate in receive and transmit simultaneously. But, requires two pair. |

If +24 Vdc is being used, resistors R116 and R118 on the Interface Board should also be removed.

When the system is configured in this manner, approximately +8 milliamperes flows through the DC control decode circuitry on the backplane. This will cause the T/R Shelf to decode a +6mA control current to key the transmitter and route line audio to the transmitter.

Tone Remote Installation

Jumpers P104 and P105 located on the Interface Board are not required and should be removed. Refer to the sections on TELEPHONE LINE CHARACTERISTICS and LEVEL ADJUSTMENTS for additional installation information. Line connections are made to TB101 or J101 on the T/R Shelf's Interface Board. TB101 and J101 are connected together and each has the same pin out.

Two Wire Tone Remote

When the control shelf is used with a two wire tone remote/console, the remote control pair should be connected to TB101-3 and TB101-4.

Four Wire Tone Remote

When the control shelf is used with a four wire tone remote/console, the remote control transmit pair (which modulates the transmitter) should be connected to TB101-2 and -5. The remote control receive pair (which listens to the receiver) should be connected to TB101-3 and TB101-4.

Connections

Phone line connections may be made on the terminal block (TB101) or with an RJ11 connector to J101. The phone line cable may be routed through the top rear or bottom rear of the cabinet (see Assembly Diagram). The phone line connections are shown in Figure 7.

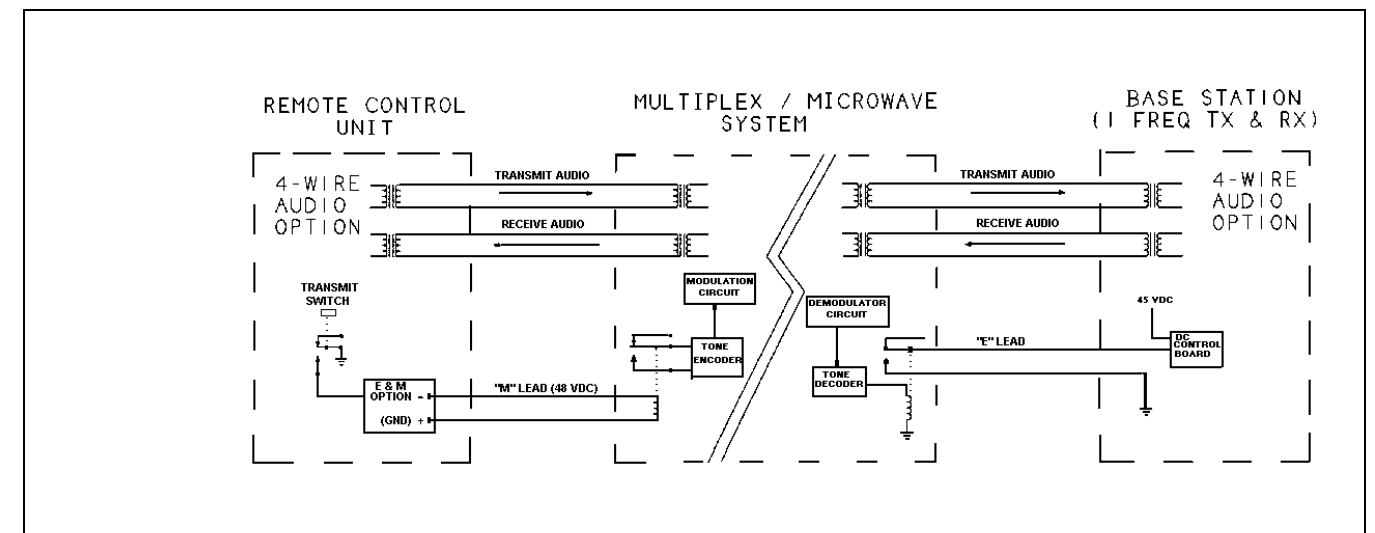
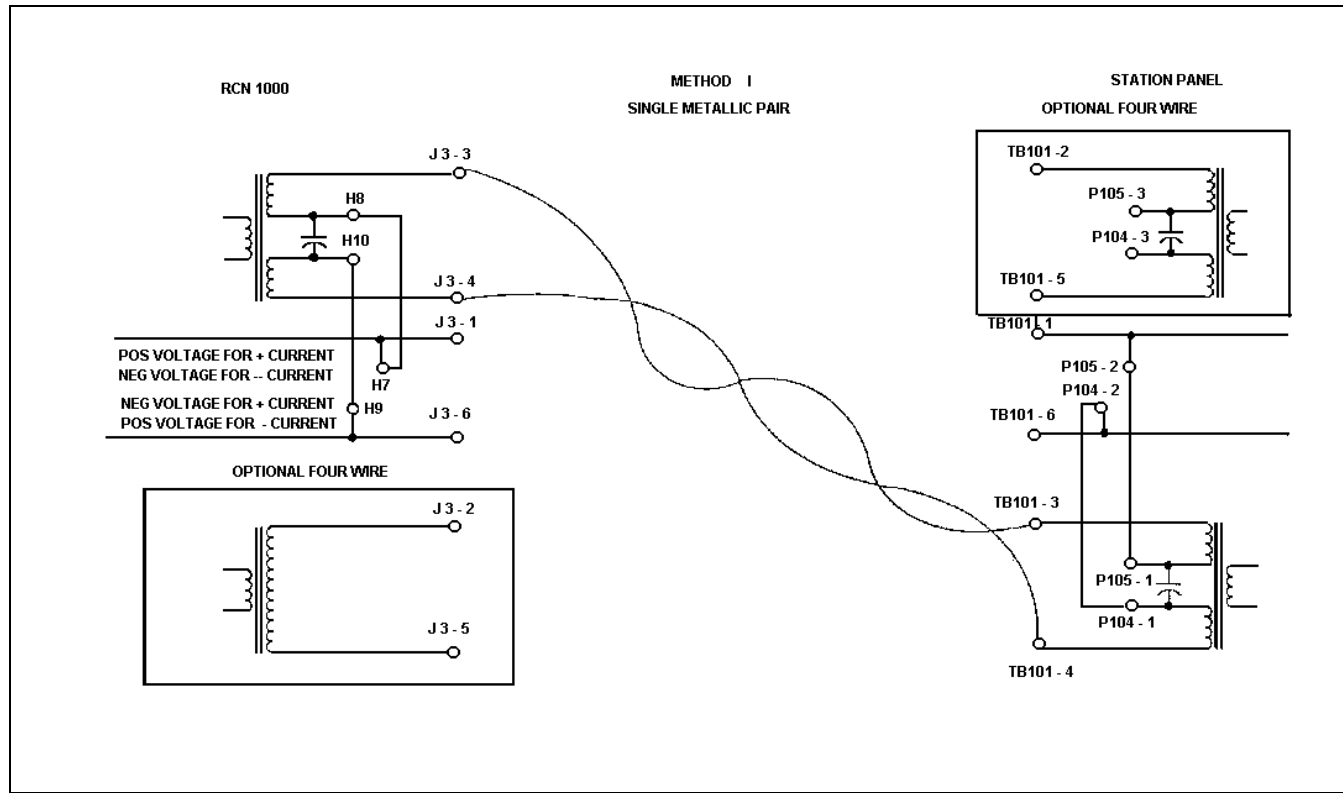
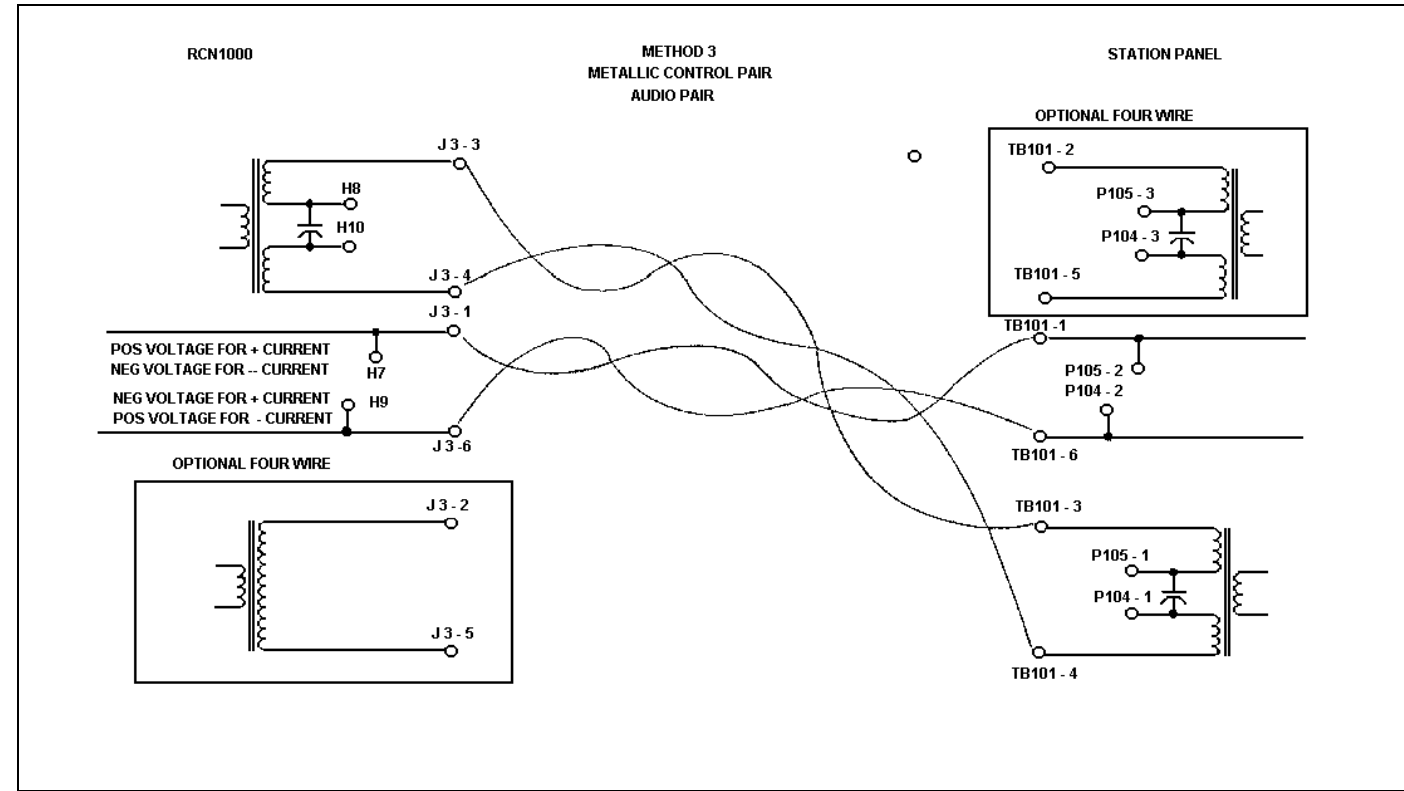

Figure 6 - Typical E & M Signalling Application



METHOD 1



METHOD 3

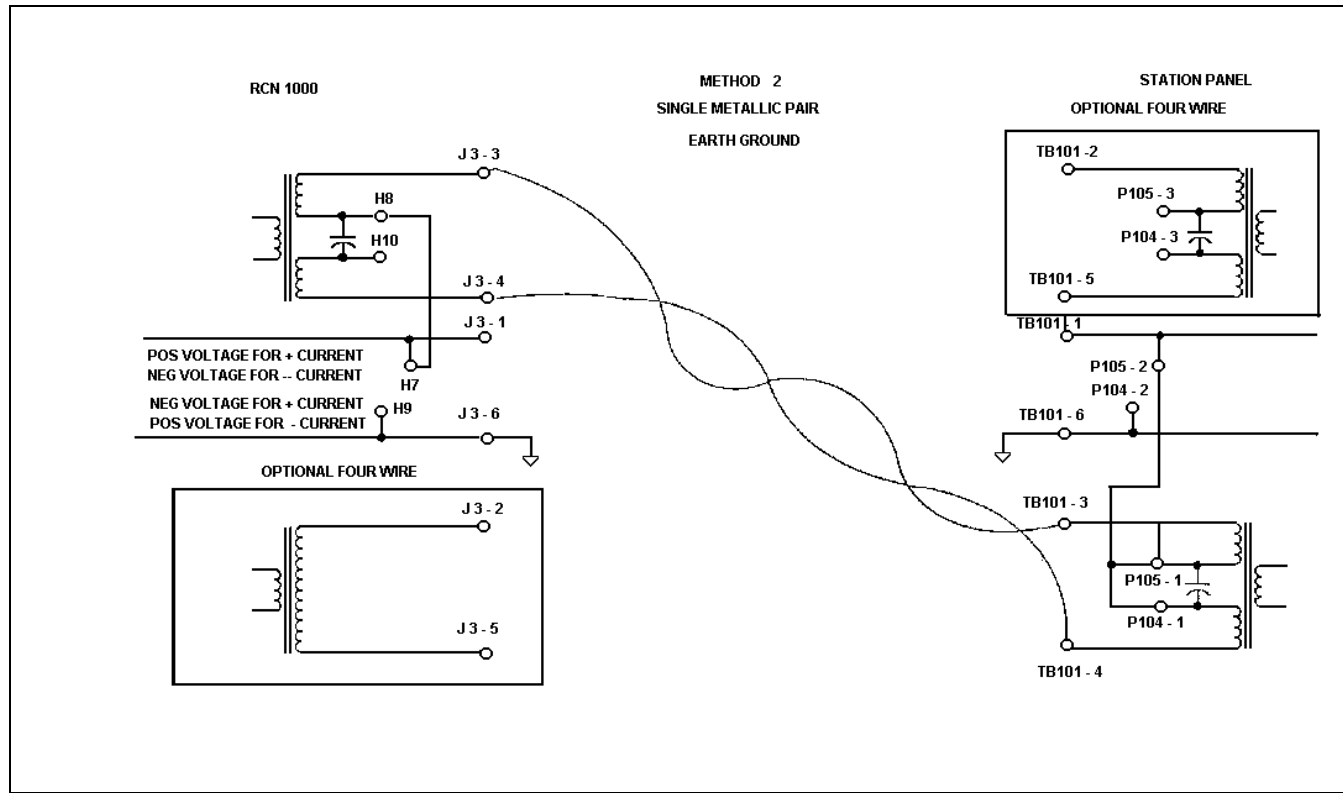

METHOD 2

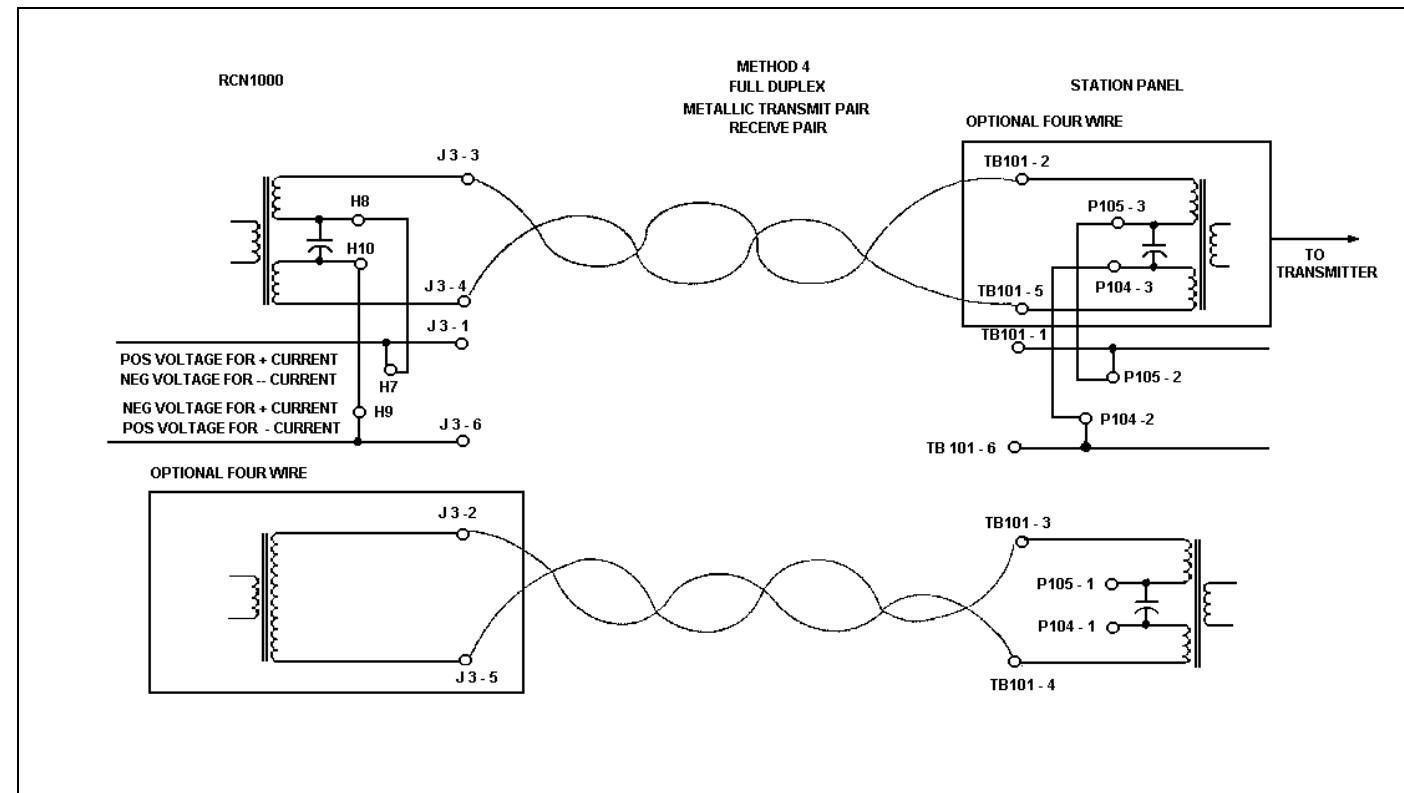

METHOD 4

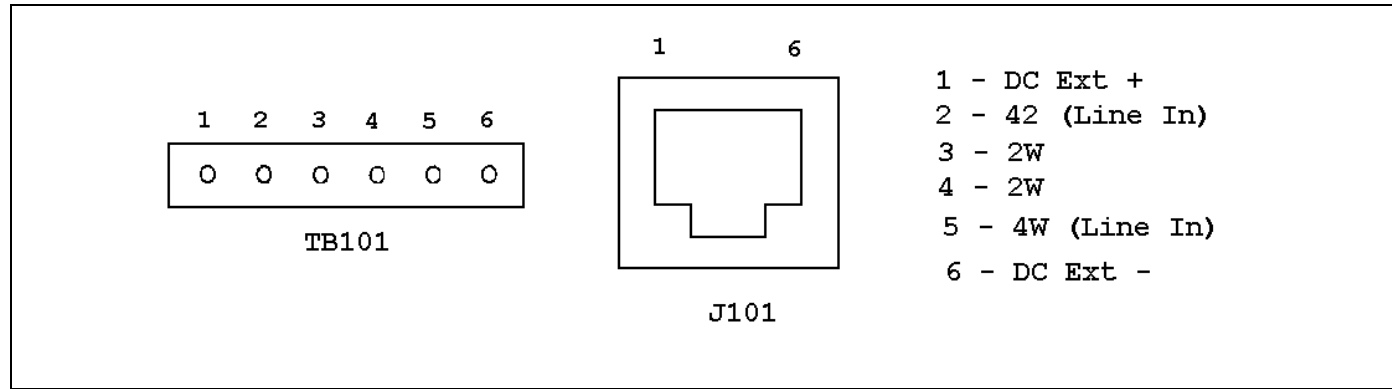

Figure 7 - Phone Line Connections

STATION SETUP

The MASTR III station comes pre-programmed and ready to install, the only adjustments needed are the required Line Output Level, the Line Input Level necessary to produce Standard Deviation, and the Line Cancellation for 2-wire Tone Remote Orientation. These adjustments can be made using the PC Programming option (TQ-3353), or Utility PC software (TQ-0619) with the Utility Handset (SPK9024).

SETUP PROCEDURE

Use the following procedures when setting up the station using an PC computer. If the Utility Handset is plugged into the MIC connector, it must be removed prior to resetting the system and using the PC Programming software. Levels may be adjusted using the MASTRUTL program supplied with the PC Programming package. A RESET (on the Power Module) should be initiated before programming starts.

1. Ensure proper connections are made to receive and transmit antenna(s). See interconnect diagram.
2. Plug the power cord from the base station into a 120 Vac, 60 Hz power source.

NOTE: If a 230 volt, 50 Hz source is used, connect the locally required plug.

3. Connect the PC computer's serial COM port and the DATA PORT on 3.

Connect the PC computer's serial COM port and the DATA PORT on the front of the T/R Shelf using the TQ-3356 Interconnect cable (19B801348P2).

If the computer has a 25-pin connector instead of a 9-pin connector, an adapter must be installed. The adapter may be either purchased or locally manufactured. Making your own requires only three wire connections.

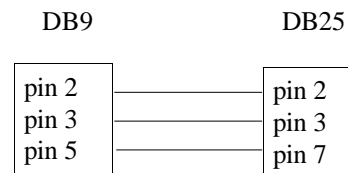

4. If the system requires control by a remote unit, the following interconnection must be made. Connect the wires from the remote unit to the six-pin terminal block (TB101). Use the following information when making connections:

| CONFIGURATION | STATION TERMINATING CONNECTOR | LOCATION |
|----------------------------|---------------------------------------|------------------------------|
| Simplex (T/R Relay) | N-Type Female | Antenna Switch |
| Duplex (Internal Duplexer) | N-Type Female | Duplexer |
| Duplex (External Duplexer) | BNC Female (Rx) N-Type Female (Tx) | T/R Shelf Low Pass Filter |

ANTENNA SYSTEM REQUIREMENTS

To supplement the manufacturer's instructions, the following hints will be valuable to you when installing your antenna.

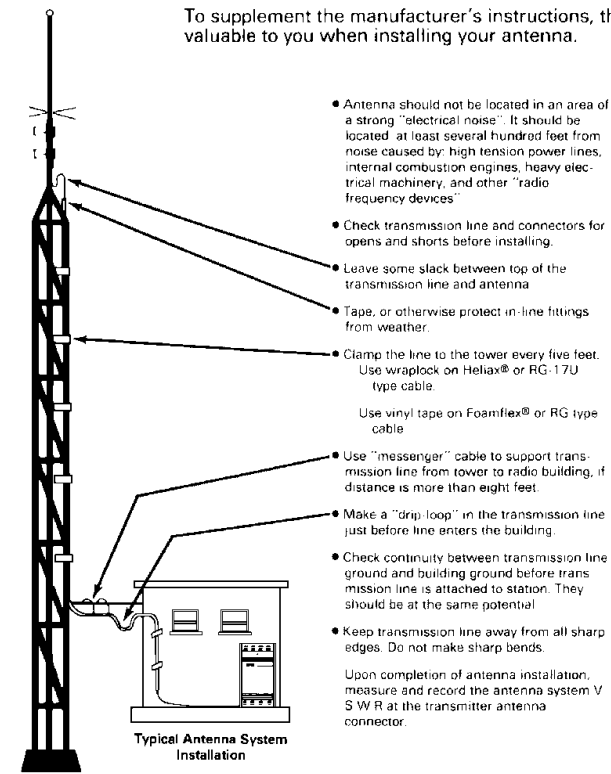

Figure 8 - Antenna Installation

TB101 pins 3,4 - Line Input/Output for 2-wire DC and Tone control.

or

Line Output for 4-wire DC and Tone control.

TB101 pins 2,5 - Line Input for 4-wire DC and Tone control.

TB101 pins 1,6 - Line Inputs for E & M signalling, DC Remote Control.

NOTE: P104 pin 1 and P105 pin 1 are on the far side of the connector if you are facing the front of the base station. Refer to Figure 8.

5. The SQUELCH and VOLUME adjustments should be made for proper operation. Unsquench the receiver by turning the SQUELCH adjustment counter-clockwise. (If your base station has Channel Guard, also activate the CG switch.) Verify that unquelled noise is going to the speaker by increasing the VOLUME (clockwise). Adjust the SQUELCH pot for critical squelch (squelch just closes).

DC REMOTE CONTROL

| | P104 | P105 | COMMENTS |
|--------|--------|--------|----------------------|
| 2-wire | 1 to 2 | 1 to 2 | Both jumpers back |
| 4-wire | 2 to 3 | 2 to 3 | Both jumpers forward |

6. Following the initial setup, the MIC port may be used for one of the following purposes:

- a. Connecting the local microphone equipped with a modular connector.
- b. Connecting the multi-purpose Utility Handset.

ALIGNMENT PROCEDURE

Alignment of the MASTR III base station was performed prior to shipment. The factory assumed the following characteristics:

1. There is no loss or gain for repeated audio deviation.
2. If a remote exists, it is connected to the base station through a telephone line with 10 dB of loss.
3. The base station drives the line output at 0 dBm with nominal receive deviation.
4. The remote drives the line nominally at 10 dBm. The signal arrives at the base station at -10 dBm resulting in nominal transmit deviation.

In other words, the base station drives 0 dBm on the line with 3 kHz of test tone into the receiver. The base station transmits at 3 kHz with -10 dBm of test tone into its line input (and REMOTE PTT active).

These values may be altered by following one of the alignment procedures provided. For minor adjustments you may want to adjust only one or two digital potentiometers or leave the setting as set. In any case, it is important to carefully examine the ALIGNMENT DIAGRAM which follows:

NOTE: It is a good idea to record the potentiometer settings on paper until you're familiar with all the digital potentiometer setting tools.

Test Equipment Required

The following test equipment is required to align the MASTR III base station:

- Audio Oscillator
- AC Voltmeter
- RF Signal Generator
- Deviation Monitor
- Handset or PC Computer

Procedure

1. Line Input (L1) Pot:
 - Set L1 pot to zero.
2. Channel Guard (CG) Pot:

If the station is not programmed for Channel Guard;

- Set the CG pot to zero(0).

If the station is programmed with Channel Guard;

- Execute a REMOTE PTT on the System Module.
- Terminate the line input with a 600 ohm load. The line inputs may also be shunted together.
- Adjust the CG pot for 750 Hz of Channel Guard TX deviation.
- Remove the REMOTE PTT.
- If a Channel Guard station, disable Channel Guard Decode.

3. Transmit Limiter (TX) pot:

- Preset the following pots as indicated:

RG = 1023
 CT = 5000
 CP = 1023
 DLI = 100

- Place a 0 dBm (775 mVrms), 1000 Hz tone on the line input.
- Key the station by executing a REMOTE PTT.
- Adjust the TX pot to a value which results in 4.5 kHz of TX deviation at the transmitter.
- Repeat this step for each channel.
- Remove the tone from the line input and release the REMOTE PTT.

4. Repeater Gain (RG) Pot:

NOTE

For Tone Remote systems, the Compressor may be active. The Compressor is usually set for compression below limiting, it is therefore important to adjust the Compressor (CT POT) to a value well above limiting (5000) in order to properly set the limiting deviation (TX POT).

Non-Repeater Station;

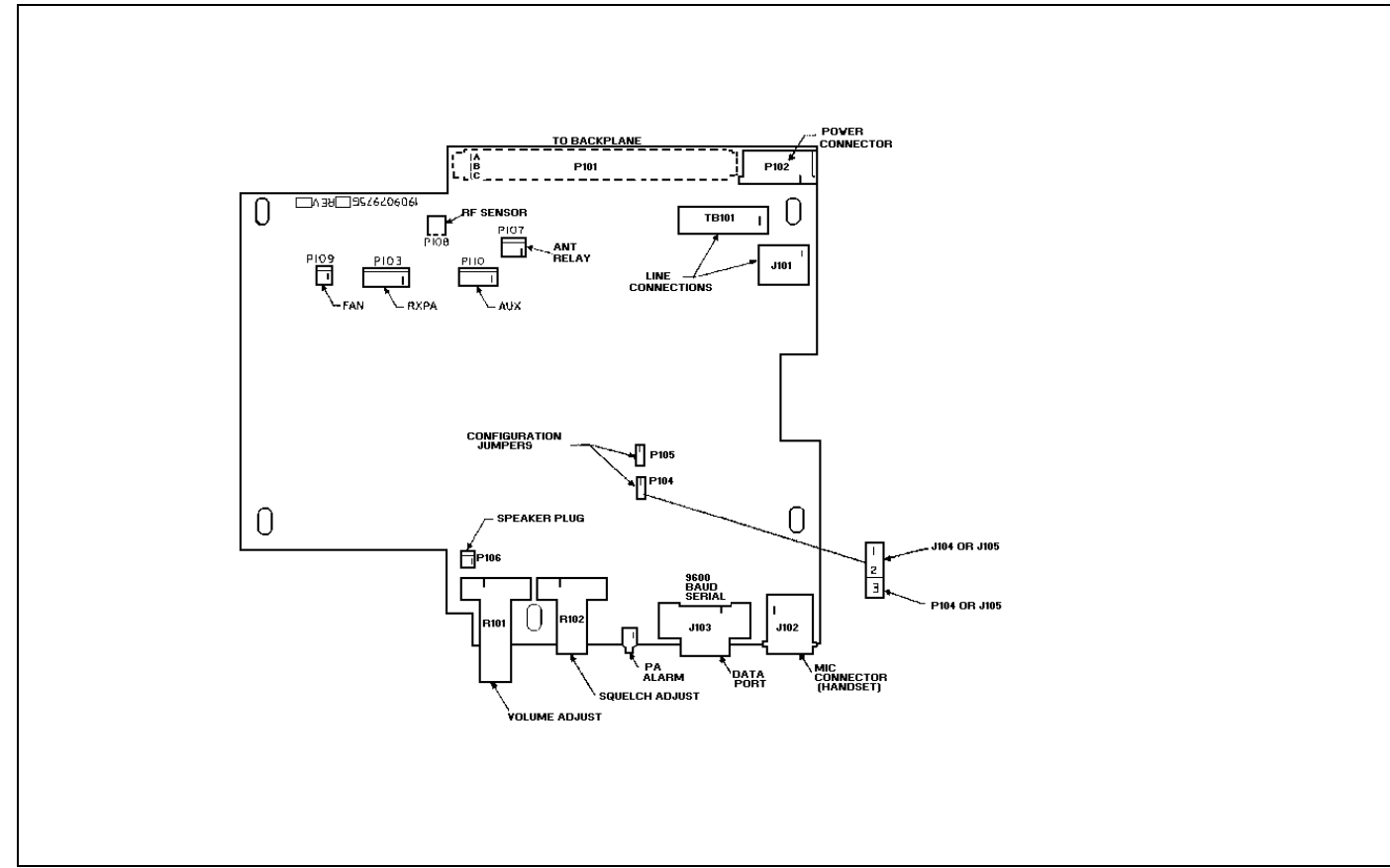

Figure 9 - T/R Shelf Interface Board

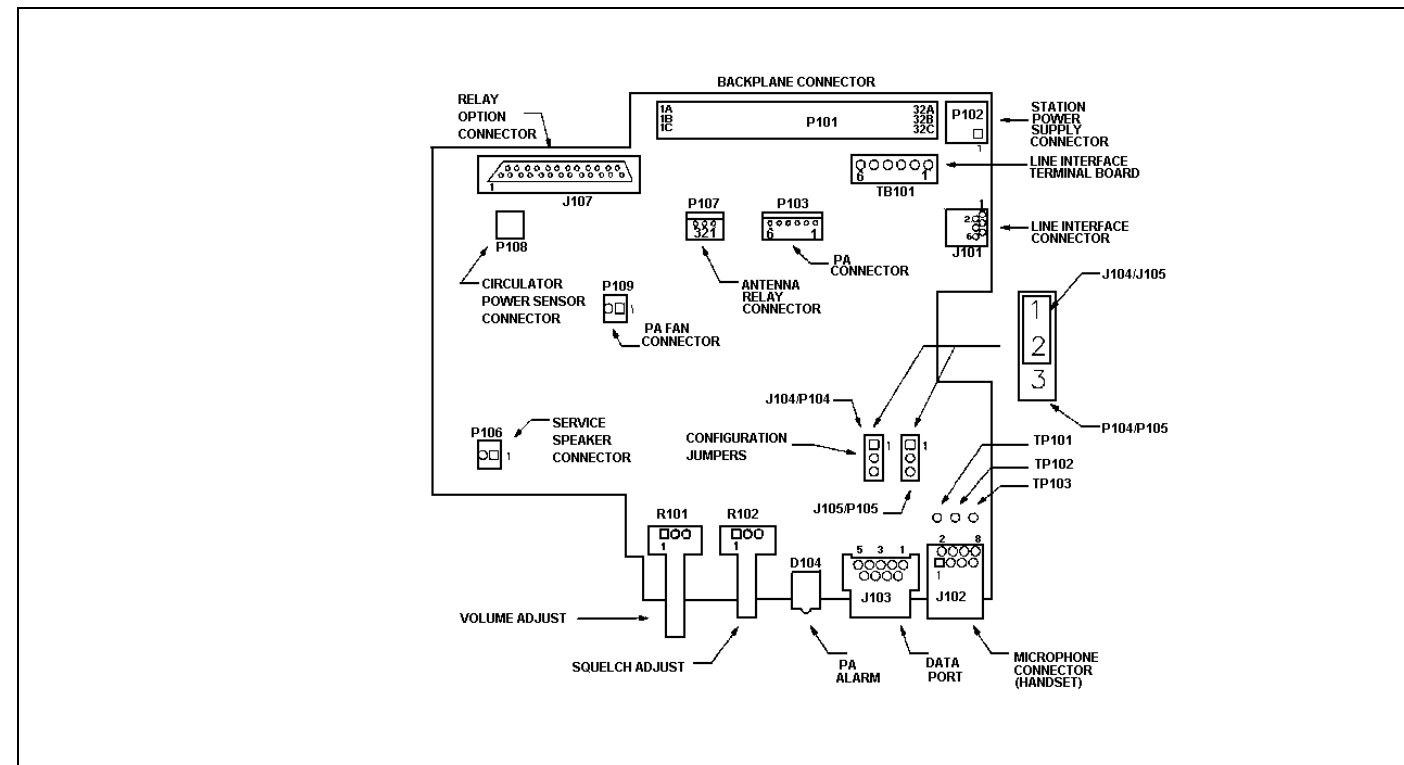

Figure 9A - T/R Shelf Interface Board (Rev. A)

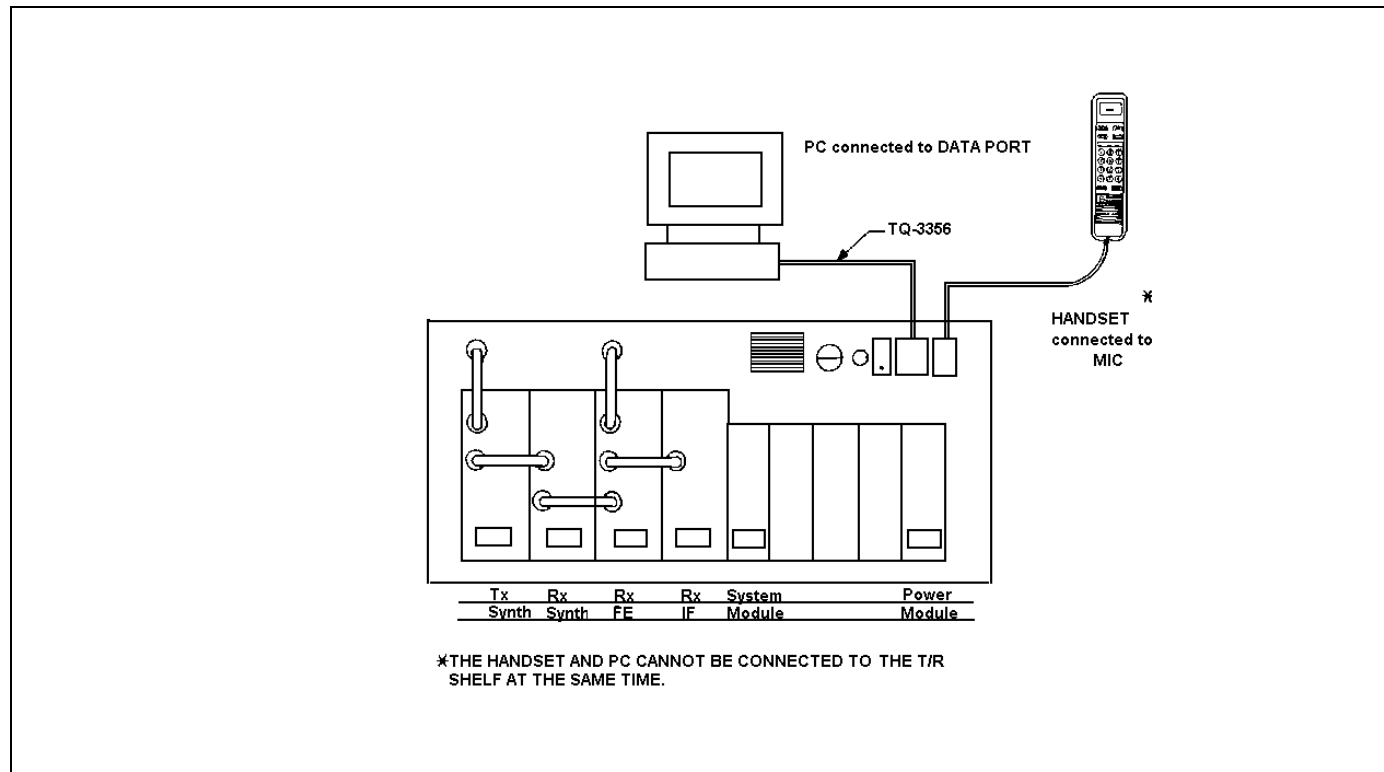

Figure 10 - T/R Shelf Connections

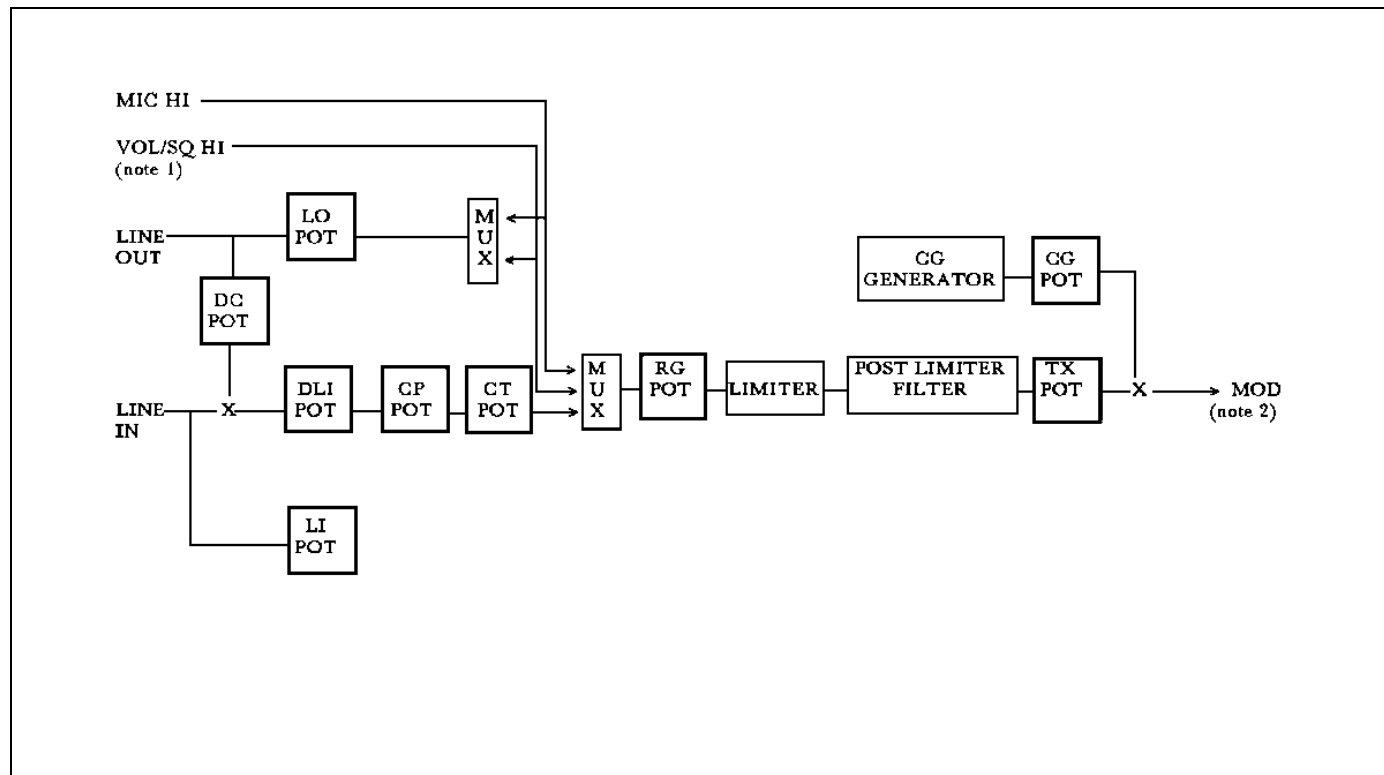

Figure 11 - MASTR III System Module Pot Alignment

| | LO POT | DC POT | LI POT | DLI POT | CP POT | CT POT | RG POT | TX POT | CG POT |
|----------------------------------|----------|------------------------|---------|--------------------|---------------------|----------------|---------------|-------------|---------------|
| | Line Out | DSP Line Cancellations | Line In | DSP Line In | DSP Compressor Gain | Comp Threshold | Repeater Gain | Transmit | Channel Guard |
| HANDSET NUMBER POT PAGE (Note 3) | 1 P_1 | 5 P_1 | 3 P_1 | 6 P_1 | 7 P_1 | 2 P_2 | 2 P_3 | 2 P_1 | 1 P_1 |
| HANDSET DISPLAY | P LO | P DC | P LI | P DI | CP | CT | RG | P TX | P CG |
| DEFAULT VALUES | 45 | 75 (2W) 6 (4W) | 0 | 34 (2W) 28 (4W) | 1023 | 1890 | 1023 | 127 150* | 123 0* |

*no Channel Guard

NOTES: 1) VOL/SQ sensitivity: 1000 mV rms = 3 kHz peak deviation (System Module, pin B2)
 2) MOD sensitivity: 1000 mV rms = 5 kHz peak deviation (System Module, pin C3)
 3) Refer to Handset manual, LBI-38599, for instructions on page selection.

- Leave the RG pot at 1023.
- Repeater Stations;
- Apply a RF signal to the receiver modulated at 60% of rated system deviation by a 1000 Hz tone.
 - Adjust the RG pot for 3.0 kHz TX deviation.
 - Set to 3.75 kHz TX deviation if Channel Guard Encode is enabled.
 - Remove the signal from the receiver.
5. DSP Line Input (DLI) Pot:
- Non-Remote Station;
- Set the DLI pot to zero (0).
- Remote Stations;
- Apply a -10 dBm (245 mVrms), 1000 Hz tone to the input line.
 - Key the station by executing a REMOTE PTT.
 - Adjust the DLI pot for 2.80 kHz TX deviation.
 - Adjust to 3.55 kHz TX deviation if Channel Guard is enabled.
 - Remove the signal from the line input and release the REMOTE PTT.
6. Compressor Gain (CP) Pot:
- Non-Remote Station;
- Set the CP pot to zero (0).
- Remote Stations;
- Apply a -10 dBm (245 mVrms), 1000 Hz tone to the input line.
 - Key the station by executing a REMOTE PTT.
 - Adjust the CT pot for 4.00 kHz TX deviation.
 - Remove the signal from the line input and release the REMOTE PTT.
7. Compressor Threshold (CT) Pot:
- Non-Remote Station;
- Set the CT pot to zero (0).
- Remote Stations;
- Apply a 0 dBm (775 mVrms), 1000 Hz tone to the input line.
 - Key the station by executing a REMOTE PTT.
 - Adjust the CT pot for 4.00 kHz TX deviation.
 - Remove the signal from the line input and release the REMOTE PTT.
8. DSP Cancellation (DC) Pot:
- Two wire Tone Remote Station;
- Set the DC pot to 75.
- All other configurations;

- Set the DC pot to zero (0).

9. Line Output (LO) Pot:

Non-Remote Station;

- Set the LO pot to zero (0).

Remote Stations;

- Apply a RF signal to the receiver modulated at 60% of rated system deviation using a 1000 Hz tone.
- Set the LO pot for a 0 dBm (775 mVrms) line output level as measured into 600 ohm load.
- Remove the signal from the receiver.
- If a Channel Guard Station, re-enable Channel Guard Decode.

AUDIO ROUTING AND ADJUSTMENTS

Once the T/R Shelf is installed and programmed properly, audio level adjustments must be made for proper system operation. Level adjustments must be made with a handset (see LBI-38599). THERE ARE NO MANUAL MECHANICAL ADJUSTMENTS IN THE T/R SHELF.

Integrated circuits (ICs) U35 and U36 on the System Board are dual electronic potentiometers that are controlled by the microprocessor. IC U15 on the DSP Board is also a dual electronic potentiometer controlled by the DSP.

TX AUDIO LEVEL ADJUSTMENT

U36-0 is used to set the transmitter deviation by adjusting the TX AUDIO output level. Analog switch U15 selects which audio source is routed to the transmitter. Possible sources are LOCAL MIC, REPEAT AUDIO, DSP LINE/TX AUDIO, DSP TX AUDIO, EXTERNAL High Speed Data, LINE IN AUDIO, OPEN (used for Morse code ID), and GROUND (used for no transmission). A battery alarm tone may also be summed in with whichever source is selected with the exception of GROUND.

Normally, LOCAL MIC, REPEAT AUDIO, DSP TX AUDIO, LINE IN AUDIO, OPEN, or GROUND will be selected. The gains in the circuitry are set such that 100 mVrms in the MIC HI or 1 Vrms (3 kHz deviation) in on VOL/SQ HI (REPEAT AUDIO) will produce the same output level on TX AUDIO HI. The gains for Morse code ID and battery alarm are also designed to provide the proper levels without adjustments. The TX AUDIO HI output level should be adjusted with a 100 mVrms, 1 kHz signal in on MIC HI or a 1 Vrms, 1 kHz signal in on VOL/SQ HI.

REMOTE CONTROLLER TO STATION CONTROL PANEL ADJUSTMENTS

Although audio levels should be considered on a system basis, it is appropriate to set the levels of the remote controller and the control station panel by themselves with reference to the levels required by the transmission path and then connect the controller(s) and station to the path. The transmission path, if it is more than just a simple twisted pair, is usually set up with a "test tone". The "average voice" level is defined as being a certain number of decibels below the test tone. The test tone is normally the maximum level that can be sent through the path without clipping or being regulated. Although there is no definite agreement on the difference between the test tone and average voice levels, 10 dB is an appropriate level.

In order to align the RCN 1000 Remote Controller and T/R Shelf properly, it will be necessary to have some information on the transmission path. This will help to determine the levels at each end required by the system. Specifications needed include:

1. Loss at 1 kHz
2. Test tone or maximum level
3. Average voice level (if defined)
4. Loss at 2175 Hz (if tone remote)

The DSP Board performs tone detection in a tone remote installation. The "Secur-it" tone Decoder on this board has a dynamic range of approximately 9 dB. The system must be set up such that the "Secur-it" tones from all remotes in the system arrive at the T/R Shelf within this 9 dB window.

LINE OUT LEVEL ADJUSTMENT

U36-1 is used to set the line out level. Analog switch U14 selects which audio source is routed to the line. Possible sources are LOCAL MIC, VOL/SQ, auxiliary receiver audio, auxiliary receiver audio summed with VOL/SQ (simultaneous monitor), DSP LINE/TX AUDIO, MODEM LINE data, OPEN (used for battery alarm), GROUND (used for no transmission), and LINE IN audio (used for four wire loop around). A battery alarm tone and/or VG ALERT tone may also be summed in with whichever source is selected with the exception of GROUND. Typically LOCAL MIC, VOL/SQ, DSP LINE/TX AUDIO, OPEN, GROUND, or LINE IN AUDIO will be selected.

The gains in the circuitry are set such that 100 mVrms in on MIC HI or 1 Vrms (3 kHz deviation) in on VOL/SQ HI (REPEAT AUDIO) will produce the same line output level. The gains for VG ALERT tone and battery alarm are also designed to provide the proper levels without adjustments. The LINE output level should be adjusted with a 100 mVrms, 1 kHz signal in on MIC HI or a 1 Vrms, 1 kHz signal in on VOL/SQ HI.

LINE IN LEVEL ADJUSTMENT

Typically, the TX AUDIO and LINE OUT levels should be adjusted prior to adjusting the LINE IN level. DSP TX AUDIO and DSP LINE/TX AUDIO are typically line audio or VOL/SQ HI audio that has been processed by the DSP Board.

If a DSP Board is present, this DSP processed line in audio will normally be selected by analog switches U14 (DSP LINE/TX AUDIO to line out) and U15 (DSP TX AUDIO to transmit audio) on the System Module when line in audio is selected. The level for DSP TX AUDIO and DSP LINE/TX AUDIO must be adjusted on the DSP Board.

DSP LEVEL ADJUSTMENTS

The LINE IN level into the DSP must be adjusted using U15-0 (DSP line cancellation level) and U15-1 (DSP line input level) located on the DSP Board. If two wire audio is used then both electronic pots must be adjusted. If four wire audio is used then only U15-1 needs to be adjusted.

For two wire installations the DSP line cancellation level pot (U15-0) is used to remove what the T/R Shelf is transmitting on the line. While the T/R Shelf is transmitting received audio down the line, the line cancellation pot should be adjusted to minimize the signal level at TP1 on the DSP Board. This leaves only what is received from the remote. This signal is then level adjusted using the DSP line input level adjust pot (U15-1) and input into the DSP.

If four wire audio is used the DSP line cancellation pot must be set to zero.

CAUTION

The line level to the DSP must be adjusted so that under all circumstances the level at TP2 of the DSP Board does not exceed 1.4 Vrms. If the level exceeds 1.4 Vrms, distortion will occur and performance can not be guaranteed.

The DSP also performs a compressor function on its line input. The threshold for this compressor must be adjusted as well. The line level should be adjusted on the DSP Board prior to setting the compressor threshold.

REPEATER PANEL INSTALLATION

CSI Model 32 Repeater Panel

Use the following information to configure the MASTR III base station when installing the CSI-32 Repeater Panel.

1. Cut the PWB pattern at JP-1 on the T/R Shelf's backplane 19D902948.
2. Make the following connections between the base station and the repeater panel. Connectors P2, P3, and P5 are located on the backplane. Connection to the repeater panel is made at J3, the rear panel DB9 subminiature "D" type connector.

NOTE

Special Conditions for MUX and Carrier

1. Add a pad of approximately 15 dB in the connection between the RCN output and the MUX input. It is common for the MUX input to have a test tone level of -16 dB and an average voice level of -29 dB.
2. Add a pad of approximately 15 dB in the connection between the Station Control panel output and the MUX input.

ACCESSORIES

The following accessories for the MASTR III Station may be obtained from your local dealer or by calling the Ericsson GE Mobile Communications Inc. After Market Services 24- hour Toll Free Number **1-800-368-3277 (USA only)** or **FAX 1-800-833-7592**. Please provide the description and part number or package number when ordering.

| | |
|--|-------------|
| Service Microphone | SZZM3B |
| Utility Handset | SPK9024 |
| Antenna Switch | 19B235897P1 |
| RF Extender Card | 19D903197G2 |
| System Module Extender Card | 19D903197G1 |
| U-link (BnC-to-BNC Coax Link) | 344A3052P1 |
| PC Programming | TQ-3353 |
| Programming Cable (DB9M-DB9F) | TQ-3356 |
| RF Module Test Fixture | TQ-0650 |
| Charger (120 Volt, 60 Hz) | 344A3168P1 |
| Charger (230 Volt, 50 Hz) | 344A3168P2 |
| Battery Backup, Gell Cell Tray | 19D903719P1 |
| Battery Backup, Gell Cell Tray Front Panel | 19C852193P1 |
| Rack Mount Duplexer (150-162 MHz) | 344A3371P1 |
| Rack Mount Duplexer (162-174 MHz) | 344A3371P2 |
| Rack Mount Duplexer (440-470 MHz) | 344A4047P1 |

3. Program the base station using the standard PC programming software. For proper operation, the station firmware must be 344A3307G12 (Group 12) or higher (MASTR III System Board - U4).

Program the following parameters:

- a. Repeater (Single Channel only)
- b. Repeater Panel option
- c. RF Duplex
- d. No CG Encode/Decode
- e. No CCT or DODT Timers
- f. Remote Control optional

4. Set the Repeat RF Modulation and Subaudible Tone (CG) Modulation levels by adjusting the Zetron 38A Repeater Panel Audio Output and CTCSS Output potentiometers or the MASTR III station's TX Audio or CG digital potentiometers.

Use the CG pot (CTCSS pot for CSI-32) to adjust the Subaudible Tone Modulation level and the TX AUDIO pot (Audio Output pot for CSI-32) to adjust the Normal Speech Modulation.

NOTE: It may be necessary to decrease the value of R5 (or short across) on the CSI Repeater Panel to obtain the desired Subaudible Tone Modulation level. Zetron 38A Repeater Panel

Zetron 38A Repeater Panel

Use the following information to configure the MASTR III base station when installing the Zetron 38A Repeater Panel.

1. Cut the PWB pattern at JP-1 on the T/R Shelf's backplane 19D902948.
2. Make the following connections between the base station and the repeater panel. Connectors P2, P3, and P5 are located on the backplane. Connection to the repeater panel is made at the 15 pin connector on the rear panel.

| CSI-32 J3 | SIGNAL NAME FUNCTION | MASTR III CONNECTION |
|-----------|-------------------------------------|----------------------|
| pin 1 | A+/(DC Power0 | P5.1 |
| pin 2 | SYS_VOL \SQ_HI/Repeat Audio) | P5.8 |
| pin 3 | RCVR_VOL\SQ_HI/ (Demodulated Audio) | P2.5 |
| pin 4 | N/C | |
| pin 5 | REPEAT_PTT_IN | P2.13 |
| pin 6 | CAS/(Carrier Activated Squelch) | P3.5 |
| pin 7,8 | DGND/(Power Ground) | P2.2, P2.3 |
| pin 9 | EXT_LSD/(CTCSS Encode) | P3.14 |

3. Program the base station using the standard PC programming software. For proper operation, the station firmware must be 344A3307G12 (Group 12) or higher (MASTR III System Board - U4).

Program the following parameters:

- a. Repeater (Single Channel only)
- b. Repeater Panel option
- c. RF Duplex
- d. No CG Encode/Decode

- e. No CCT or DODT Timers
- f. Remote Control option

4. Set the Repeat RF Modulation and Subaudible Tone (CG) Modulation levels by adjusting the Zetron 38A Repeater Panel Audio Output and CTCSS Output potentiometers or the MASTR III station's TX Audio or CG digital potentiometers.

Use the CG pot (CTCSS pot for Zetron 38A) to adjust the Subaudible Tone Modulation level and the TX AUDIO pot (Audio Output pot for Zetron 38A) to adjust the Normal Speech Modulation.

| ZETRON 38A | SIGNAL NAME FUNCTION | MASTR III CONNECTION |
|------------|------------------------------------|----------------------|
| pin 1 | A+/(DC Power) | P5.1 |
| pin 2 | N/C | |
| pin 3,4 | DGND/(Power ground) | P2.2, P2.3 |
| pin 5,6 | N/C | |
| pin 7 | REPEAT_PTT_IN | P2.13 |
| pin 8,9 | N/C | |
| pin 10 | CAS/(Carrier Activated Squelch) | P3.5 |
| pin 11 | SYS_VOL \SQ_HI/(Repeat Audio) | P5.8 |
| pin 12 | N/C | |
| pin 13 | EXT_LSD/(CTCSS Encode) | P3.14 |
| pin 15 | RCVR_VOL\SQ_HI/(Demodulated Audio) | P2.5 |

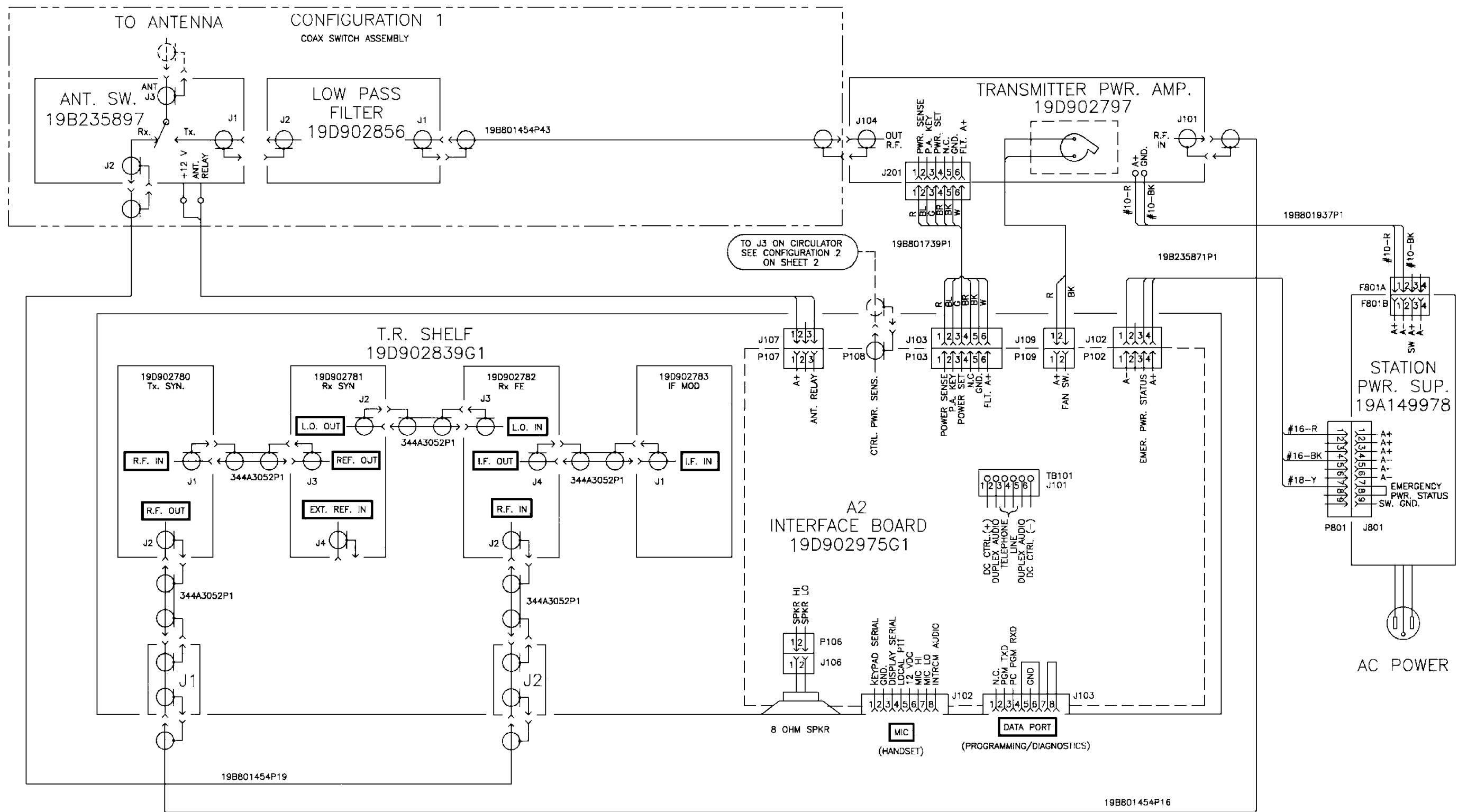

**MASTR III STATION
T/R Shelf Interconnect**

(19D903635, Sh. 1, Rev. 4)

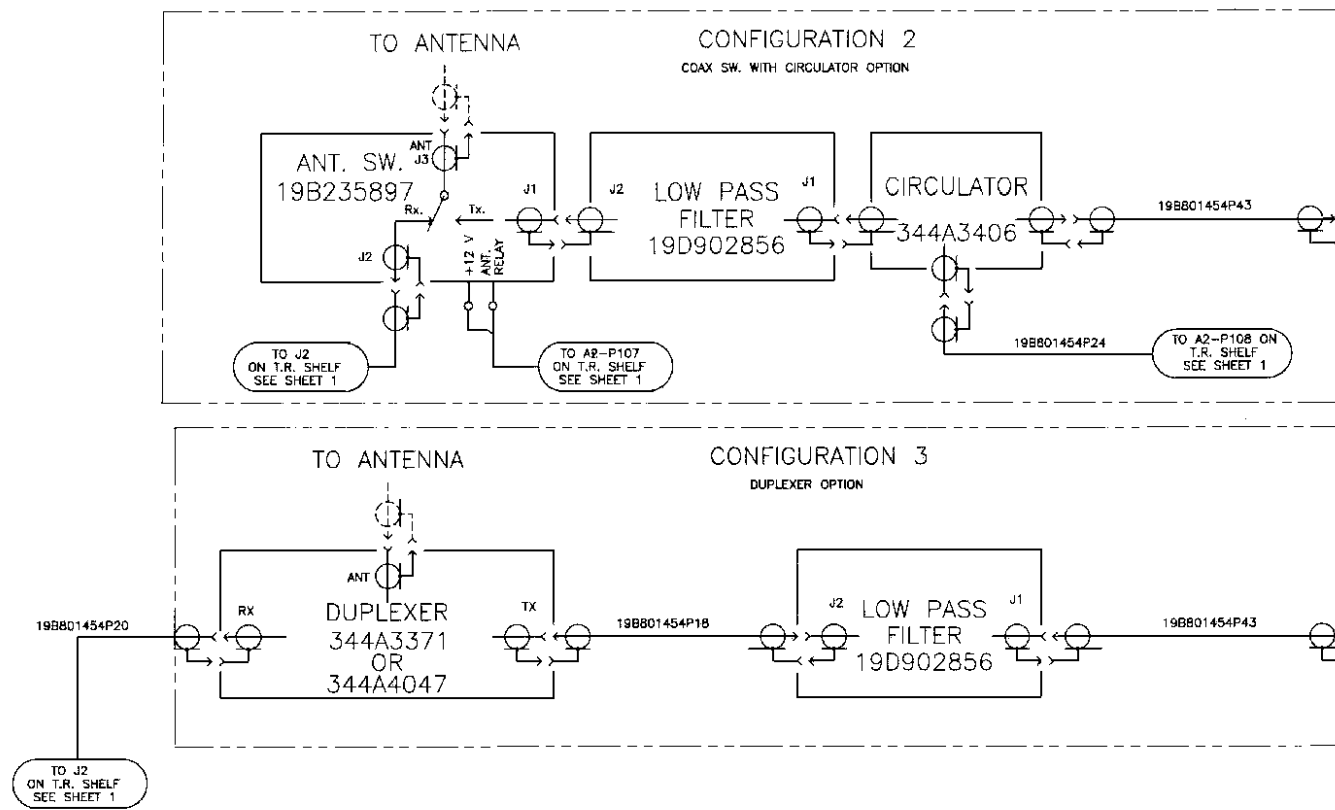

MASTR III STATION
 Antenna Configuration Interconnect

(19D903635, Sh. 2, Rev. 6)

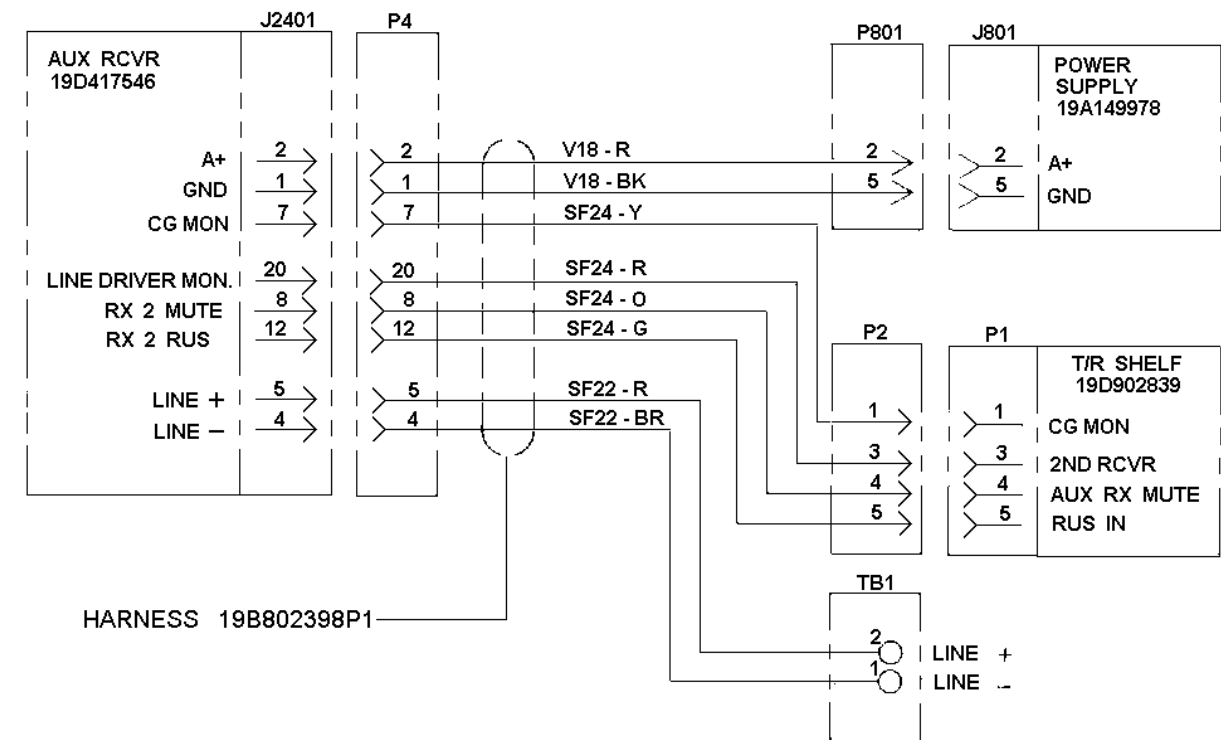

MASTR III STATION
 Auxiliary Receiver Interconnect

(19B802439, Rev. 1)

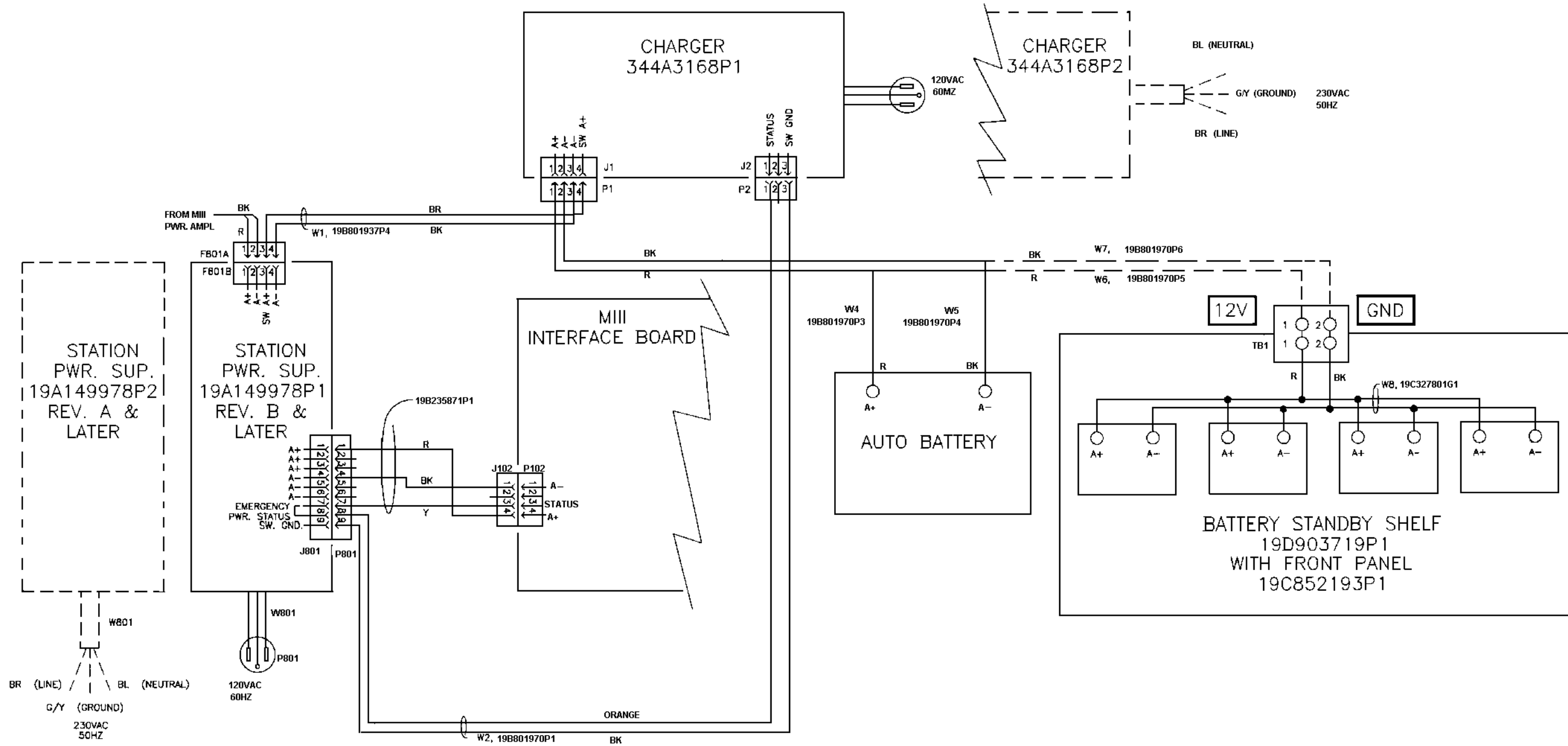

**MASTR III STATION
Emergency Power Interconnect**

(19D902635, Sh. 3, Rev. 2)

INTERCONNECTION DIAGRAM

LBI-38636

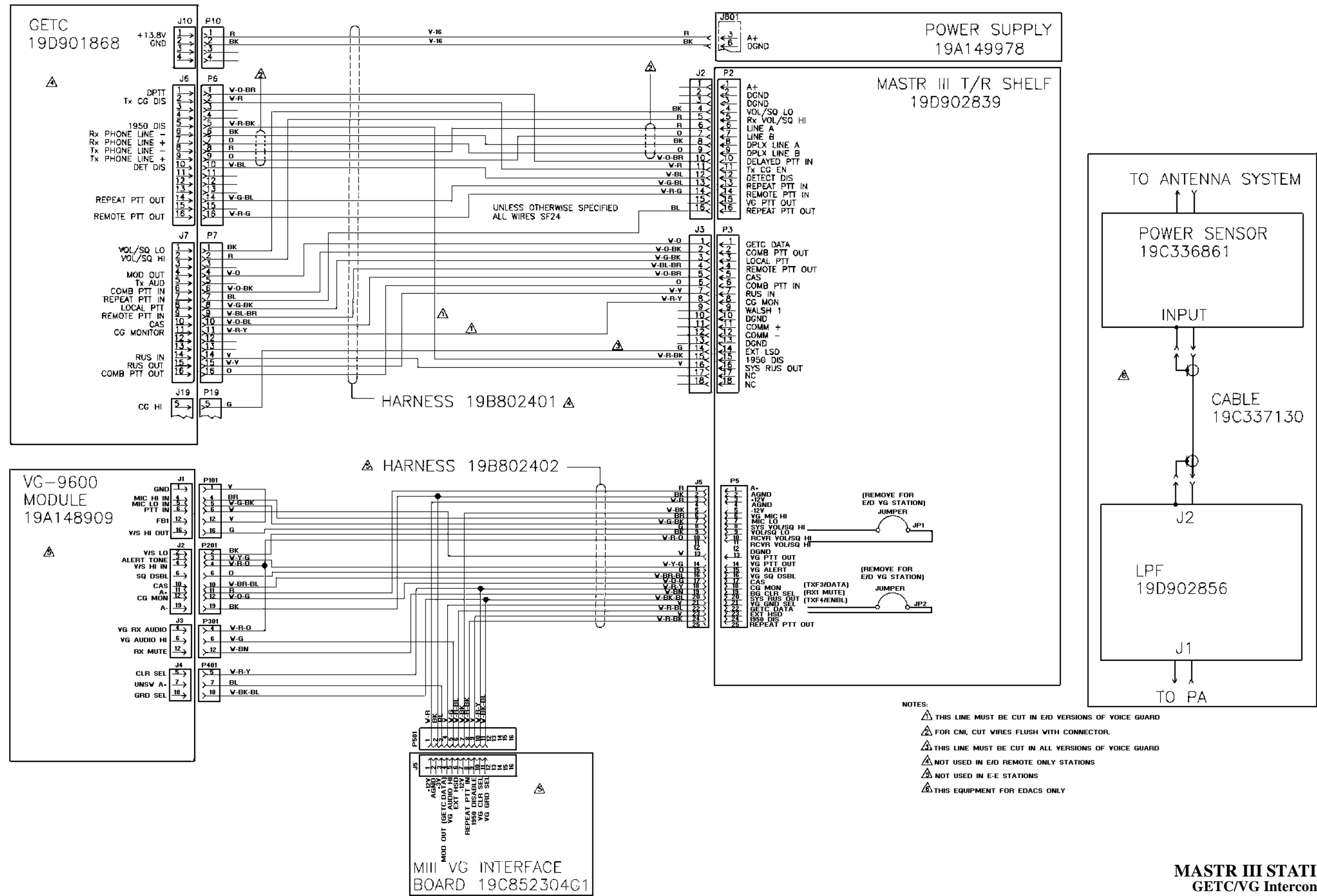

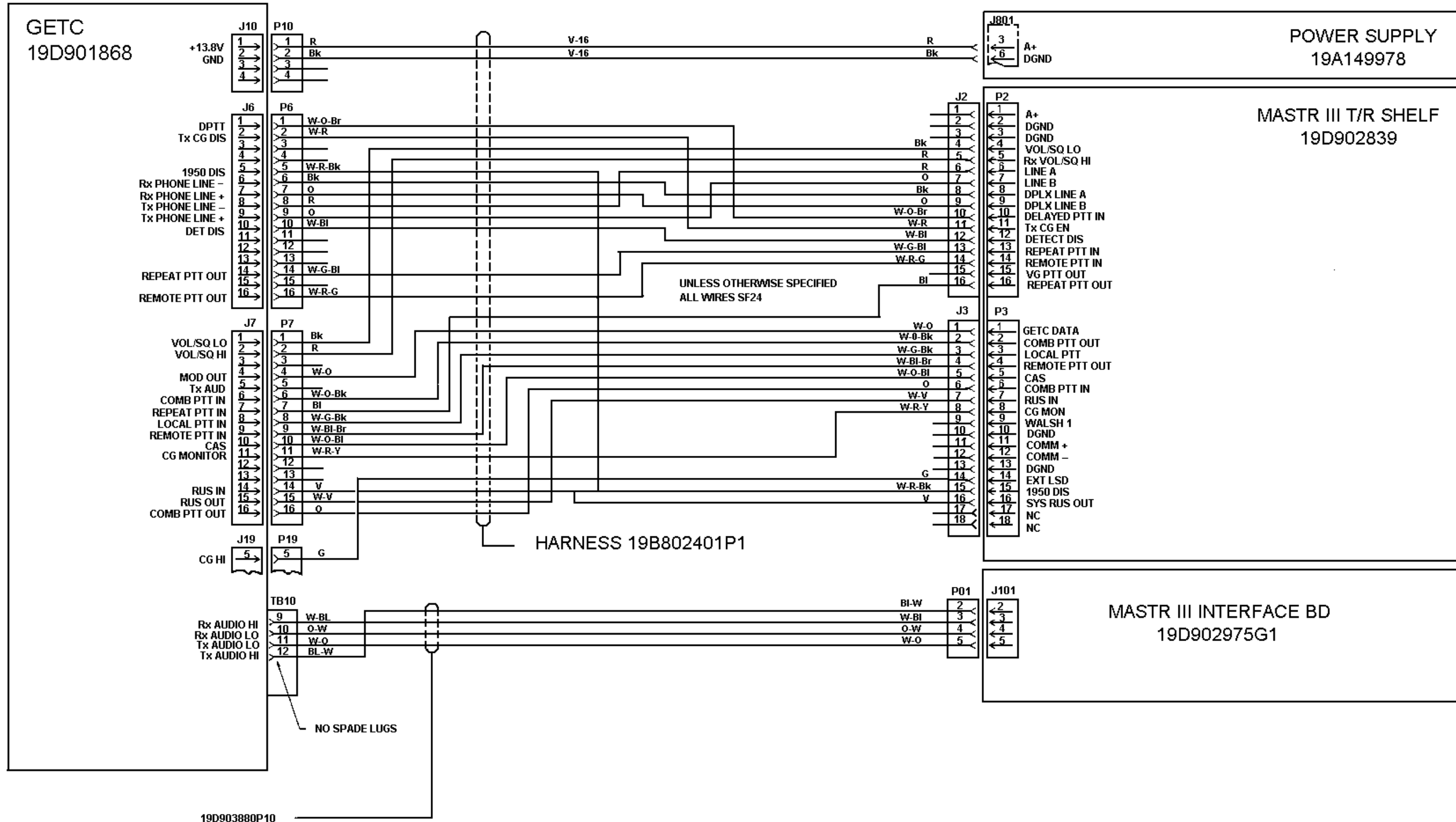

MASTR III STATION
SCAT

THIS PAGE INTENTIONALLY LEFT BLANK