

MAINTENANCE MANUAL FOR
450-470 MHz, 110 WATT POWER AMPLIFIER
19D902797G3
425-450 MHz, 90 WATT POWER AMPLIFIER
19D902797G7
403-425 MHz, 90 WATT POWER AMPLIFIER
19D902797G6
380-400 MHz, 75 WATT POWER AMPLIFIER
19D902797G8
470-494 MHz, 90 WATT POWER AMPLIFIER
19D902797G9
492-512 MHz, 90 WATT POWER AMPLIFIER
19D902797G10
410-430 MHz, 90 WATT POWER AMPLIFIER
19D902797G11

TABLE OF CONTENTS

DESCRIPTION	1
SPECIFICATIONS	1
CIRCUIT ANALYSIS	1
POWER AMPLIFIER	1
Exciter	1
Small Signal Gain Stage	1
Low Level Amplifier	1
Driver	1
Power Amplifier Finals	1
POWER CONTROL	2
Theory of Operation	2
Signal Interface	2
TROUBLESHOOTING GUIDE	2,3
BLOCK DIAGRAM	1
POWER AMPLIFIER READINGS	3
ASSEMBLY DIAGRAM	5,6,7
PARTS LIST	8
PRODUCTION CHANGES	10
IC DATA	11
OUTLINE DIAGRAM	10,12
SCHEMATIC DIAGRAM	11,12
LOW PASS FILTER	7,13

Table 1 - General Specifications	
ITEM	SPECIFICATION
FREQUENCY	450 MHz - 470 MHz (G3) 403 MHz - 425 MHz (G6) 425 MHz - 450 MHz (G7) 380 MHz - 400 MHz (G8) 470 MHz - 494 MHz (G9) 492 MHz - 512 MHz (G10) 410 MHz - 430 MHz (G11)
OUTPUT POWER (RF)	65 watts - 130 watts (G3) 55 watts - 110 watts (G6, G7, G9, G10 & G11) 45 watts - 90 watts (G8)
INPUT POWER (RF)	10 mW min. into ≤ 2:1 VSWR.
TEMPERATURE RANGE	-30°C TO +60°C (Ambient air)
SUPPLY VOLTAGE	13.4 Vdc
CURRENT	29 Amps max. (26 A typical @ rated power, 13.4V) (G3) 29 Amps max. (21 A typical @ rated power, 13.4V) (G6, G7, G9, G10 & G11) 29 Amps max. (20 A typical @ rated power, 13.4V) (G8)
DUTY CYCLE	Continuous
STABILITY	Stable into 3:1 VSWR; all temp., voltage, freq. 55 watts - 110 watts (G3) or 45 watts - 90 watts (G6, G7, G9, G10 & G11) or 45watts - 90 watts (G8)
RUGGEDNESS AT HIGH VSWR	No damage into open or shorted load.

DESCRIPTION

The UHF Power Amplifier Assembly is a wide band RF power amplifier operating over the 380-400, 410-430, 403-425, 425-450, 450-470, 470-494, and 492-512 MHz range without tuning. Its main function is to amplify the 10 mW FM signal from the Transmitter Synthesizer to the rated RF output at the antenna port. The output of the Power Amplifier Assembly is adjustable from rated power to 3dB lower at the PA output J104.

The assembly consists of a printed wiring board (A1) and associated components, including a power module and three RF power transistors, mounted to the heat sink assembly. The printed wiring board (A1) contains both the power amplifier circuitry and the power control circuitry.

Unfiltered supply voltage, A+, for the power amplifier circuits enters the assembly via feedthrough capacitor, C1. Power cable W4 routes the A+ from C1 to J103 on the PWB. Filtered A+ voltage for the power control circuit enters the assembly via control cable W13 which connects to the PWB at J201.

The Power Control circuitry sets the output power level by adjusting the PA Power Set level. It keeps the output power constant despite variations in input power, power amplifier gain, or temperature through the use of a feedback control loop in the PA assembly.

CIRCUIT ANALYSIS

POWER AMPLIFIER

The power amplifier section of the PA Board consists of an Exciter, a Small Signal Gain Stage, a Low Level Amplifier, a Driver, and the Power Amplifier Finals. All these gain stages have an input and output impedance of 50 ohms. Figure 1 is a block diagram showing the signal flow within the Power Amplifier Assembly.

Exciter (U101)

The Exciter stage uses a broadband silicon monolithic microwave integrated circuit (MMIC) amplifier. The signal from transmitter synthesizer, typically 10 dBm (10 mW), is input to the Exciter through a 10 dB resistive pad (R1, R2, and

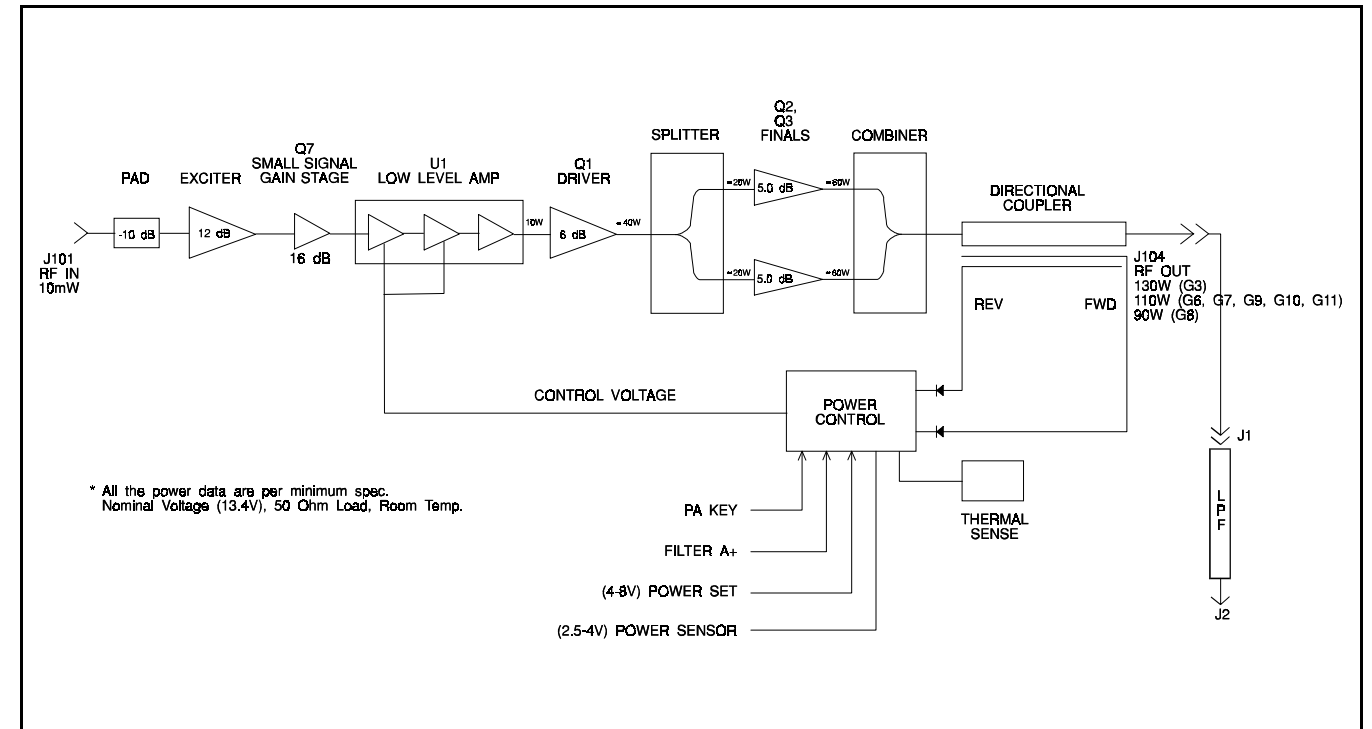

Figure 1 - Block Diagram

R31). The Exciter amplifies the resulting 0 dBm (1 mW) signal to 12 dBm (16 mW).

The MMIC requires a 5 volt supply source. The 8 volt regulator (U100) provides the 5 volts to the MMIC via a dropping resistor R30.

Small Signal Gain Stage

The Small Signal Gain Stage consists of Q7 and its associated bias and matching circuitry. Collector voltage is fed through R39, R40, and L23. Resistor R33 sets the quiescent bias of the part. The transistor input impedance is matched to the 50 ohm output of the Exciter by C59, C61, C62, and C63. L24 provides the necessary output matching. The stage provides 14 dB of gain to amplify the signal from the Exciter to 26 dBm (400 mW).

Low Level Amplifier (U102)

The Low Level Amplifier (LLA) stage uses a 50 ohm thick film RF Power Module to amplify and control of the output power. Internally, the module is a three stage amplifier. The power control circuitry controls the gain of the first and second stages by varying the collector voltage level of Q203. The third stage gain remains constant with A+ providing the DC supply voltage.

The signal from the Small Signal Gain stage, typically 26 dBm (400 mW), is input into the LLA. Under typical

Power Set conditions, the LLA amplifies the signal to a typical output level of 40.5 dBm (11.2 W).

Driver (Q1)

The driver is a 6 dB RF amplifier consisting of transistor Q1 and its associated circuitry. The signal from the LLA, typically 40.5 dBm (11.2 W), is amplified to 46.5 dBm (45.0 W). The transistor input is matched to 50 ohms by C65, C66, C27, C67, and a piece of printed transmission line. The drive signal is then split with a printed in-phase Wilkinson splitter, providing equal power to each of the final devices.

Power Amplifier Finals (Q2, Q3)

Each of the Power Amplifier Final devices is capable of producing 5 to 6 dB of gain. The output signal from the Splitter is impedance matched to each of the finals. Under optimum conditions each final amplifies the input signal to between 50 and 70 watts output power (depending on band split). The outputs are then impedance matched to the input of the Combiner. The Combiner is a printed in-phase Wilkinson type which combines (sums) the output power of the finals. This produces an output power of approximately 100W, (depending on band split) which is coupled to the directional coupler (part of A1 PWB) and on to the antenna circuits. In addition, the directional coupler samples both forward and reverse power and sends this sample to the Power Control circuitry.

POWER CONTROL

The Power Control circuitry performs three basic functions. It keys and unkeys the PA, sets the PA output power, and protects the PA against adverse conditions.

Keying and Unkeying the PA

To key the PA, the digital controller places 5 volts on the PA key line, J201-2. Zero volts on the PA key line causes the PA to unkey. If the control cable (W13) is disconnected, with nothing actively driving the PA key line, the PA will remain unkeyed.

PA Output Power Set

PA output power is set according to the level of the Power Set line. Four (4) volts on this line will produce minimum power. As the voltage increases toward eight (8) volts, the power will increase to its maximum rated output. The PA output power is initially set at the factory. This is done by adjusting R43 while injecting a 10 mW signal at J1 and applying 8 volts to J201-3. After setting the maximum power level, changing the output power is done by varying the voltage applied on the Power Set line.

PA Protection

The power control also protects the PA against over temperature and high VSWR conditions.

An over temperature condition exists when the flange temperature of the final output transistor reaches 80°C. At this point the output power will drop below its set level. The output power will continue to drop such that when the flange temperature reaches 125°C the PA output drops at least 10 dB below its set level.

Reflected power is limited to 25% of the set power. If the output VSWR degrades to worse than 3:1 the forward power will be reduced to limit the reflected power to 25% of the set power. The Power Sensor line indicates when the PA is operating in a cutback condition. If the PA is keyed and the power control is cutting back, the Power Sensor line will drop to zero (0) volts and the PA alarm light on the station will turn on.

Theory of Operation

Power control of the MASTR III Power Amplifier is accomplished with a feedback control loop. The three possible feedback signals are: representation of forward power, temperature sensitive scaled representation of forward power, or representation of reflected power. These three signals are input to a diode summing junction which selects the largest of the three for use as the feedback.

The stripline directional coupler samples the output power and produces a voltage, Vf, proportional to the forward output power. The power control compares the forward voltage, Vf, to a reference voltage at U3. The output of U3 controls the current flow thru Q5 and the output of Q203. The collector output of Q203 adjusts the control voltage, Vct1 and Vct2. This control voltage is capable of adjusting the total PA output power since it provides the first two stages DC supply to the Low Level Amplifier, U1.

During over temperature operation, a scaled representation of the forward power is maintained constant by varying the control voltage line. Thermal resistor RT1 sensing an increase in temperature causes the output of U3.1 to increase. If the output of U3.1 becomes larger than the other feedback lines, the output of U3.4 will begin to decrease. This in turn will cause the output of Q203 to decrease reducing the supply voltage to U1. Since the scaling is a function of temperature the power is reduced as the temperature increases.

Under VSWR cutback operation the reverse voltage, Vr, representative of the reflected output power is held below a threshold by reducing the control voltage as necessary. If Vr increases at U3.1 beyond the preset threshold an increase at U3.4 will result. This causes a subsequent reduction in the control voltage to U1. Thus the power control circuit reduces the output power in order to limit the reflected power to 25% of the set power.

Signal Interface

The signal interface to the MASTR III Power Amplifier is supported by a six position feedthrough connector, J201, with the following pinout:

- 1 – PWR Sensor
- 2 – PA Key
- 3 – PA PWR Set
- 4 – NC
- 5 – Ground
- 6 – Fil A+

Pwr Sensor

This line indicates when the PA is experiencing adverse conditions. Under normal operation, while the PA is keyed, this line will be proportional to forward power. Minimum power (zero watts) corresponds to 2.5 volts while maximum power corresponds to 4.5 volts. This voltage is not temperature compensated and no effort is made to calibrate this signal to an absolute power level. It is intended to provide a relative indication of forward power and to discriminate between normal and cutback operation.

Zero volts on this line, when the PA is keyed, indicates the forward power is cutback. This power cutback may be due to high reflected power or may be due to high PA temperatures. This fault condition may indicate a problem with the PA or may indicate a system problem external to the Power Amplifier. High VSWR may be due to a poor antenna and high temperature may be due to a blocked cabinet vent. Zero volts on this line, when the PA is keyed, does not indicate zero forward power. Zero volts indicates the PA is protecting itself due to adverse conditions. If the adverse condition, either high VSWR or high temperature is eliminated, the power will return to normal and the PWR SENSOR voltage will rise above 2.5 volts.

PA Key (Interface Connector pin 2)

This line is used to key and unkey the PA. UNKEY = 0 volt and KEY = 5 volts. The driver of this line must be capable

of supplying 5 volts at 1.0 mA. The appropriate key sequence requires RF from the transmit synthesizer be input to the PA before the KEY line is energized.

PA PWR Set (Interface Connector pin 3)

This line is used to set the RF Power Output of the PA. Minimum power output equals 4 volts and maximum power output equals 8 volts. The driver of this line must be capable of supplying 8 volts at 1.0 mA.

Fil A+ (Interface Connector pin 6)

This line provides the filtered supply voltage for the Power Control. The driver of this line must be capable of supplying 13.4 volts ±20% at 100 mA.

TROUBLESHOOTING GUIDE

SYMPTOM	AREAS TO CHECK	INDICATIONS
1. No Power or low Power at Antenna Port.	1. Measure the transmitter output power before the duplexer or antenna switch (for simplex mode).	The presence of power at this port is an indication of a defective duplexer, switch, or cables.
	2. Measure the transmitter output power before the low pass filter.	The presence of power at this port is an indication of a defective filter or cables.
	3. Measure the transmitter output power before the optional isolator at the PA output port.	The presence of power at this port is an indication of a defective isolator or cables.
2. No power at PA output port and PA ALARM is OFF.	1. Station is in receive mode.	
3. No power at PA output port and PA ALARM is ON.	1. No RF input to PA. Check connection between PA and TX Synthesizer.	TX Synthesizer should deliver a minimum of 10 mW (10 dBm) to the PA.
	2. Check the logic or DC inputs to the PA from the Interface Board through J201.	
	a. J201-2 PA KEY	5volts during transmit
b. J201-3 POWER SET	4 volts to 8 volts (4 volts represents zero RF power)	
c. J201-6 13.8 VF	13.8 Vdc ±20%	
3. Defective PA		Replace PA

TROUBLESHOOTING GUIDE (cont'd)

**UHF POWER AMPLIFIER TYPICAL VOLTAGE READINGS
(50 ohm, room temperature, 13.4 Vdc supply voltage, and rated output)**

SYMPTOM	AREAS TO CHECK	INDICATIONS
4. Low power at PA output port and PA ALRAM is OFF.	<ol style="list-style-type: none"> Low RF input to PA from TX Synthesizer. Check the voltage on J201-3 (POWER SET). Check the power supply voltage on the collector of Q1, Q2 and Q3 One of the two final PA transistors (Q2 or Q3) is defective. 	<p>Power should be a minimum of 10 mW (10 dBm).</p> <p>For minimal output power, this voltage should be above 7 volts.</p> <p>Voltage should be minimal 13.4 Vdc.</p> <p>Replace the defective transistor.</p>
5. Low power at PA output port and PA ALARM is ON.	<ol style="list-style-type: none"> Check for over temperature and/or a high VSWR condition due to a mismatch at the output port. 	<p>The power control circuit protects the PA by cutting back the power. In case of a mismatch, refer to symptom 1.</p>

UHF POWER AMPLIFIER VOLTAGE CHART

PARAMETER (50 ohm, -30°C to +60°C)	REFERENCE SYMBOL	READINGS (volts DC)
SUPPLY VOLTAGE	A+	13.4 V ±20%
CONTROL VOLTAGE	Vct1	0 - 12 V
FORWARD VOLTAGE	Vf	3 - 7 V
REVERSE VOLTAGE	Vr	2 - 6 V
POWER SENSE	J201-1	2.5 - 4 V
PA KEY	J201-2	5 V
POWER SET	J201-3	4 - 8 V
13.8 VF	J201-6	13.8 V ±20%

	Group	Low	Mid	High
Frequency	G3	450 MHZ	460 MHZ	470 MHZ
	G6	403 MHZ	414 MHZ	425 MHZ
	G7	425 MHZ	437 MHZ	450 MHZ
	G8	380 MHZ	390 MHZ	400 MHZ
	G9	470 MHZ	482 MHZ	494 MHZ
	G10	492 MHZ	502 MHZ	512 MHZ
	G11	410 MHZ	420 MHZ	430 MHZ
Vct 1 (Volts DC)	G3	7 - 10 Volts	6 - 8 Volts	4 - 6 Volts
	G6	6 - 8 Volts	6 - 8 Volts	6 - 8 Volts
	G7	6 - 8 Volts	6 - 8 Volts	6 - 8 Volts
	G8	6 - 8 Volts	6 - 8 Volts	6 - 8 Volts
	G9 & G10	6 - 8 Volts	6 - 8 Volts	6 - 8 Volts
	G11	6 - 8 Volts	6 - 8 Volts	6 - 8 Volts
Vf (Volts DC)	G3	5 - 7 Volts	5 - 7 Volts	5 - 7 Volts
	G6	6 - 8 Volts	6 - 8 Volts	6 - 8 Volts
	G7	6 - 8 Volts	6 - 8 Volts	6 - 8 Volts
	G8	6 - 8 Volts	6 - 8 Volts	6 - 8 Volts
	G9 & G10	6 - 8 Volts	6 - 8 Volts	6 - 8 Volts
	G11	6 - 8 Volts	6 - 8 Volts	6 - 8 Volts
Vr (Volts DC)	G3	2 - 3 Volts	2 - 3 Volts	2 - 3 Volts
	G6	2 - 3 Volts	2 - 3 Volts	2 - 3 Volts
	G7	2 - 3 Volts	2 - 3 Volts	2 - 3 Volts
	G8	2 - 3 Volts	2 - 3 Volts	2 - 3 Volts
	G9 & G10	2 - 3 Volts	2 - 3 Volts	2 - 3 Volts
	G11	2 - 3 Volts	2 - 3 Volts	2 - 3 Volts
J201 - 1 (Volts DC)	G3	2.5 - 4 Volts	2.5 - 4 Volts	2.5 - 4 Volts
	G6	2.5 - 4 Volts	2.5 - 4 Volts	2.5 - 4 Volts
	G7	2.5 - 4 Volts	2.5 - 4 Volts	2.5 - 4 Volts
	G8	2.5 - 4 Volts	2.5 - 4 Volts	2.5 - 4 Volts
	G9 & G10	2.5 - 4 Volts	2.5 - 4 Volts	2.5 - 4 Volts
	G11	2.5 - 4 Volts	2.5 - 4 Volts	2.5 - 4 Volts
J201 - 3 (Volts DC)	G3	6 - 8 Volts	6 - 8 Volts	6 - 8 Volts
	G6	6 - 8 Volts	6 - 8 Volts	6 - 8 Volts
	G7	6 - 8 Volts	6 - 8 Volts	6 - 8 Volts
	G8	6 - 8 Volts	6 - 8 Volts	6 - 8 Volts
	G9 & G10	6 - 8 Volts	6 - 8 Volts	6 - 8 Volts
	G11	6 - 8 Volts	6 - 8 Volts	6 - 8 Volts
J201- 6 (Volts DC)	G3	13.4 Volts	13.4 Volts	13.4 Volts
	G6	13.4 Volts	13.4 Volts	13.4 Volts
	G7	13.4 Volts	13.4 Volts	13.4 Volts
	G8	13.4 Volts	13.4 Volts	13.4 Volts
	G9 & G10	13.4 Volts	13.4 Volts	13.4 Volts
	G11	13.4 Volts	13.4 Volts	13.4 Volts

RATED POWER FOR MASTR III UHF BASE STATION

FREQUENCY MHz	STANDARD @J2	ADJUSTABLE RANGE @J104	WITH DUPLEXER	WITH ISOLATOR	WITH DUPLEXER AND ISOLATOR
450-470	110W	65-130W	75W	100W	70W
425-450	90W	55-110W	60W	82W	55W
403-425	90W	55-110W	60W	82W	55W
380-400	75W	45-90W	50W	68W	47W
410-430	90W	55-110W	60W	82W	55W
470-494	90W	55-110W	60W	82W	55W
492-512	90W	55-110W	60W	82W	55W

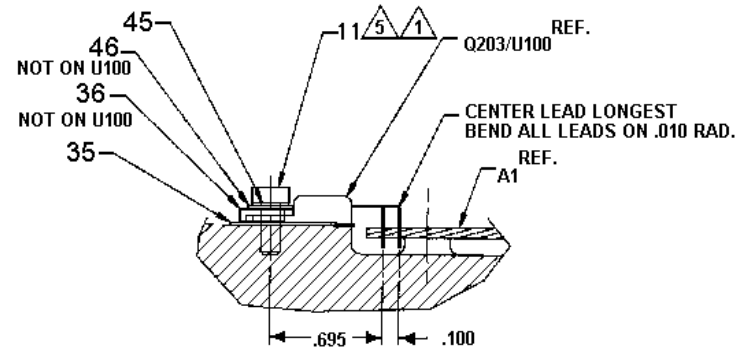

SECTION C - C
(TAKEN FROM SHEET 1)

LEAD FORMING AND HARDWARE
STACKUP FOR Q203 & U100
FOR Q203, U100 USE
EGE TOOL #423445G1A

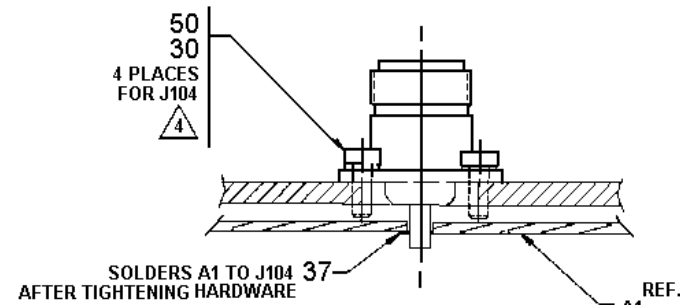

SECTION D - D
(TAKEN FROM SHEET 1)

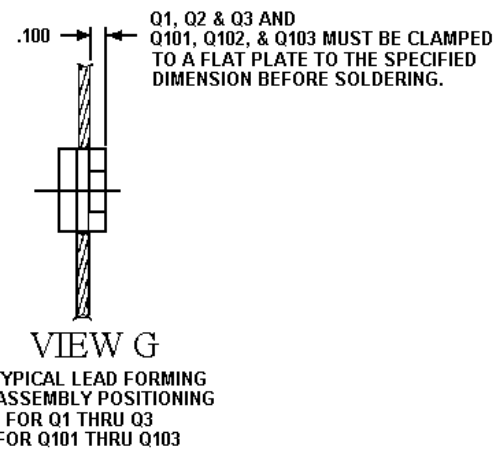
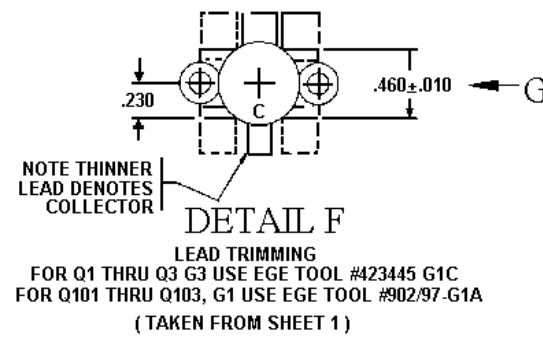

POWER AMPLIFIER ASSEMBLY
19D902797G3, G6, G7, G8, G9, G10 & G11

(19D902797 Sh.2 Rev.6)

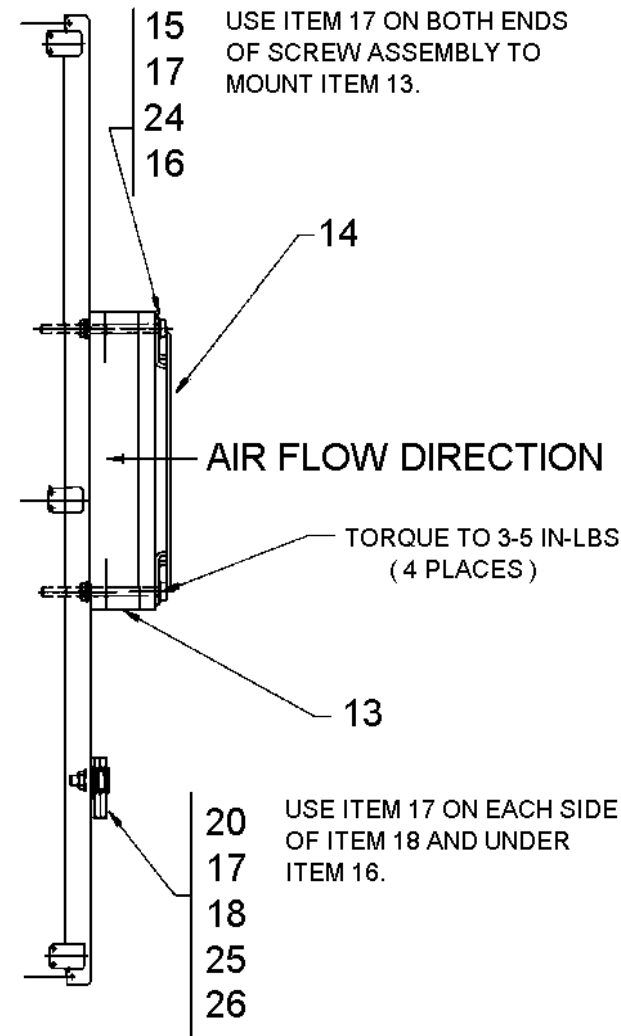

COVER ASSEMBLY
19B801659G3

(19B801659, Sh. 2, Rev. 3)

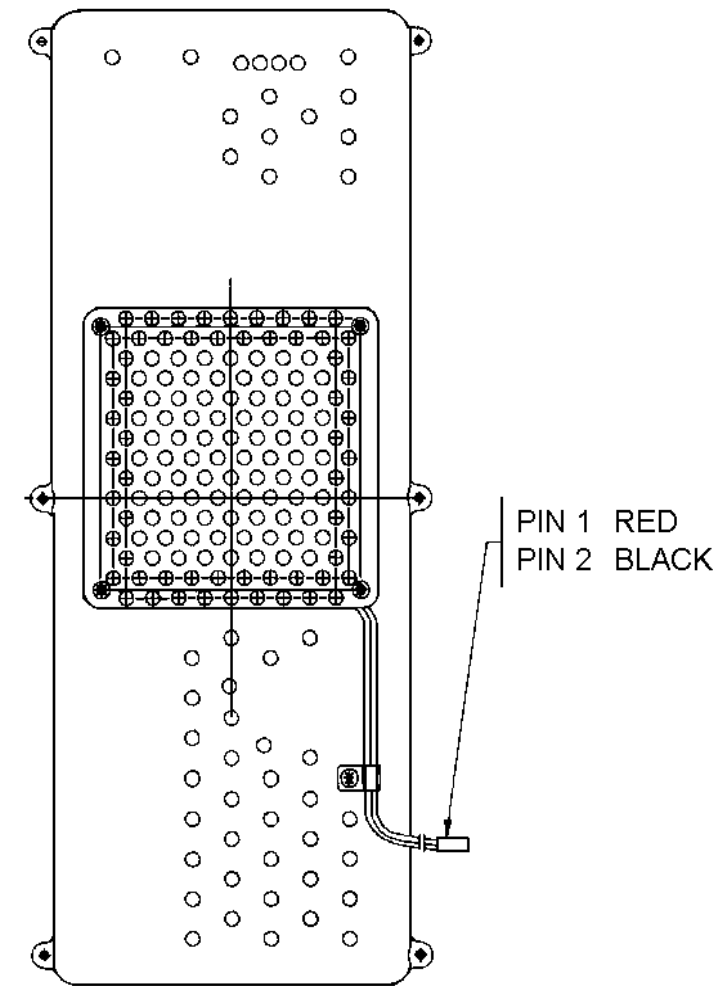

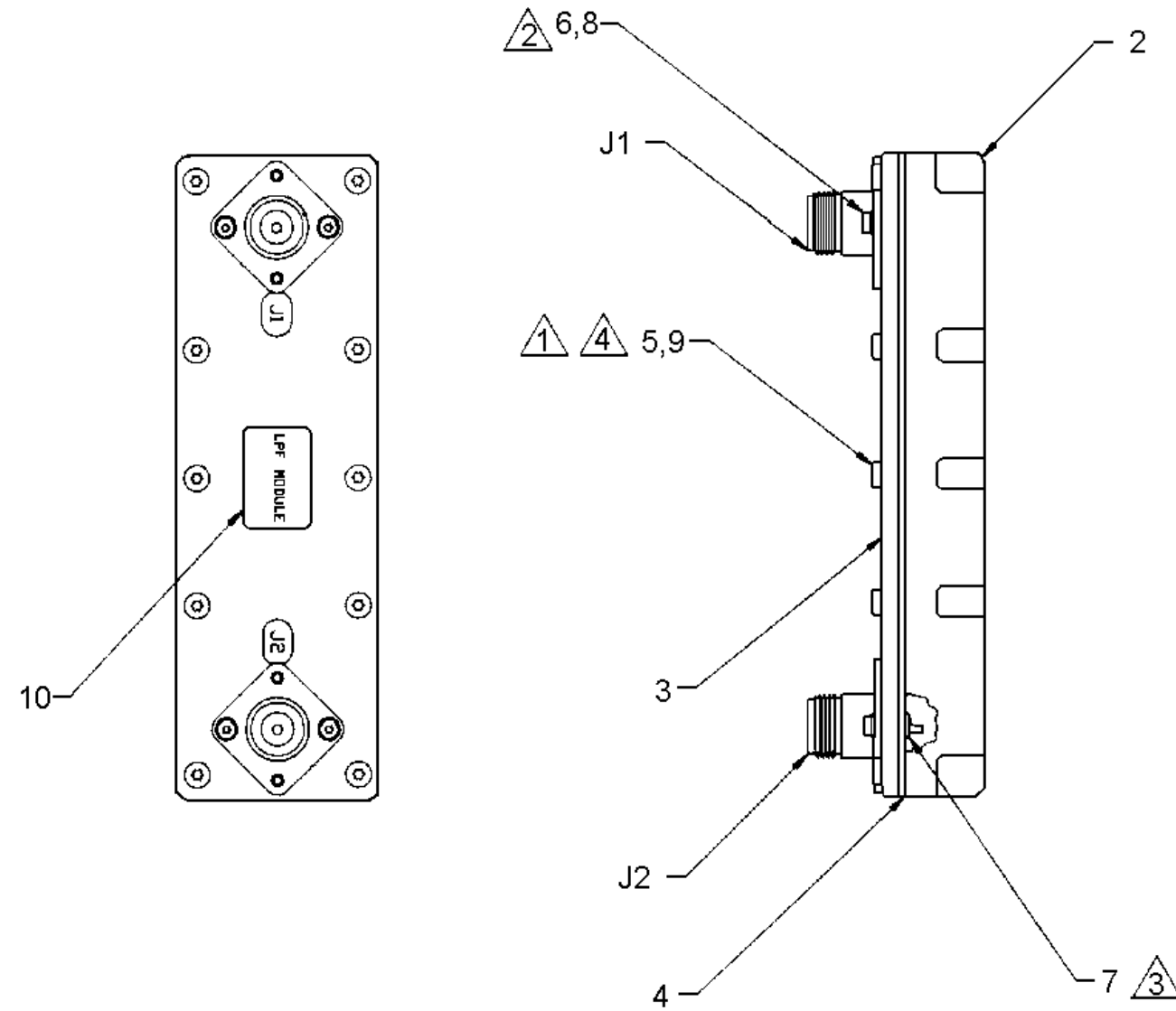

NOTES:

- ① TORQUE SCREW, ITEM 5, TO 15.5±1.3 IN-LB.
- ② TORQUE SCREW, ITEM 6, TO 6 IN-LBS.
- ③ SOLDER CONNECTORS J1 AND J2 AND ITEM 7 TO ITEM 4.
- ④ COAT THREADS OF SCREW, ITEM 5, WITH LUBRICANT, BEFORE INSTALLING.

LOW PASS FILTER MODULE
19D902856G3

(19D902856 Sh.1 Rev.0)

110 WATT UHF POWER AMPLIFIER 19D902797G3
90 WATT UHF POWER AMPLIFIER 19D902797G6, G7
& G9 - G11
75 WATT UHF POWER AMPLIFIER 19D902797G8
ISSUE 4

SYMBOL	PART NUMBER	DESCRIPTION
A1		----- ASSEMBLIES ----- POWER AMPLIFIER BOARD 19D902794G3, G6 - G11 ----- CAPACITORS -----
C1	19A116708P2	Feedthru: 0.01uF +100-0%, 500 VDCW; sim to Erie 327-050-X5W0103P.
C1	19A702052P26	Ceramic: 0.1 uF ±10%, 50 VDCW,
C2 thru C9	19A702061P63	Ceramic: 120 pF ±5%, 50 VDCW, temp coef 0 ±30 PPM.
C10	344A3126P38	Porcelain: 100 pF ±5%, 500 VDCW. sim to 101JT500X.
C11	19A702061P63	Ceramic: 120 pF ±5%, 50 VDCW, temp coef 0 ±30 PPM.
C12	19A705108P40	Mica chip: 120 pF, ±5%, 100 VDCW. temp coef 0 ±50 PPM°C.
C13 thru C16	344A3126P38	Porcelain: 100 pF ±5%, 500 VDCW. sim to 101JT500X.
C17	19A702052P26	Ceramic: 0.1 uF ±10%, 50 VDCW.
C18	19A705108P40	Mica chip: 120 pF, ±5%, 100 VDCW. temp coef 0 ±50 PPM°C.
C19	344A3126P38	Porcelain: 100 pF ±5%, 500 VDCW. sim to 101JT500X.
C20 and C21	19A705108P40	Mica chip: 120 pF, ±5%, 100 VDCW. temp coef 0 ±50 PPM°C.
C22 and C23	19A702052P26	Ceramic: 0.1 uF ±10%, 50 VDCW.
C24	19A702061P63	Ceramic: 120 pF ±5%, 50 VDCW, temp coef 0 ±30 PPM.
C25	344A3126P38	Porcelain: 100 pF ±5%, 500 VDCW. sim to 101JT500X.
C26	344A3126P62	Porcelain: 1000 pF ±5%, 500 VDCW; sim to 102JT500X.
C27	344A3126P13	Porcelain: 15 pF ±5%, 500 VDCW; sim to 100JT500X. (Used in G7 and G8).
C27	344A3126P15	Porcelain: 12 pF ±5%, 500 VDCW; sim to 120JT500X. (Used in G6 and G11).
C28	344A3126P18	Porcelain: 15 pF ±5%, 500 VDCW; sim to 150JT500X. (Used in G8).
C28	344A3126P15	Porcelain: 12 pF ±5%, 500 VDCW; sim to 120JT500X. (Used in G6).
C28	344A3126P13	Porcelain: 15 pF ±5%, 500 VDCW; sim to 100JT500X. (Used in G11).
C28	344A3126P11	Porcelain: 8.2 pF ±5%, 500 VDCW; sim to 8R2CT500X. (Used in G7).
C29	344A3126P18	Porcelain: 15 pF ±5%, 500 VDCW; sim to 150JT500X. (Used in G8).
C29	344A3126P15	Porcelain: 12 pF ±5%, 500 VDCW; sim to 120JT500X. (Used in G6).
C29	344A3126P13	Porcelain: 15 pF ±5%, 500 VDCW; sim to 100JT500X. (Used in G11).
C29	344A3126P11	Porcelain: 8.2 pF ±5%, 500 VDCW; sim to 8R2CT500X. (Used in G7).
C30	344A3126P15	Porcelain: 12 pF ±5%, 500 VDCW; sim to 120JT500X. (Used in G8).
C30	344A3126P11	Porcelain: 8.2 pF ±5%, 500 VDCW; sim to 8R2CT500X. (Used in G3, G9, G10).
C31	344A3126P15	Porcelain: 12 pF ±5%, 500 VDCW; sim to 120JT500X. (Used in G8).

* COMPONENTS, ADDED, DELETED OR CHANGED BY PRODUCTION CHANGES

SYMBOL	PART NUMBER	DESCRIPTION
C31	344A3126P11	Porcelain: 8.2 pF ±5%, 500 VDCW; sim to 8R2CT500X. (Used in G3, G9, G10).
C32 and C33	344A3126P1	Porcelain: 3.3 pF ±.25pF, 500 VDCW; sim to 3R3CT500X. (Used in G3).
C34 and C35	344A3126P18	Porcelain: 15 pF ±5pF, 500 VDCW; sim to 150JT500X. (Used in G6, G7 and G11).
C36	344A3126P3	Porcelain: 3.9 pF ±0.25%, 500 VDCW; sim to 3R9CT500X. (Used in G8).
C36	344A3126P5	Porcelain: 4.7 pF ±0.25%, 500 VDCW; sim to 4R7CT500X. (Used in G6 and G11).
C37	344A3126P2	Porcelain: 2.2 pF ±0.25%, 500 VDCW; sim to 2R2CT500X. (Used in G8).
C38	19A705205P7	Tantalum: 10 uF, 25 VDCW; sim to Sprague 293D. (Used in G8, G9, G10 and G11).
C39	19A705108P40	Mica chip: 120 pF, ±5%, 100 VDCW. temp coef 0 ±50 PPM°C. (Used in G8, G9, G10 and G11).
C40	19A702052P26	Ceramic: 0.1 uF ±10%, 50 VDCW. (Used in G8, G9 and G10).
C41	344A3126P38	Porcelain: 100 pF ±5%, 500 VDCW. sim to 101JT500X. (Used in G11).
C42 thru C45	19A702052P26	Ceramic: 0.1 uF ±10%, 50 VDCW.
C46 and C47	344A3126P11	Porcelain: 8.2 pF ±5%, 500 VDCW; sim to 8R2CT500X. (Used in G9 and G10).
C48	19A702052P26	Ceramic: 0.1 uF ±10%, 50 VDCW.
C50	19A702052P26	Ceramic: 0.1 uF ±10%, 50 VDCW.
C51	19A705205P7	Tantalum: 10 uF, 25 VDCW; sim to Sprague 293D.
C53 and C54	19A705205P7	Tantalum: 10 uF, 25 VDCW; sim to Sprague 293D.
C57	19A705205P7	Tantalum: 10 uF, 25 VDCW; sim to Sprague 293D.
C58	344A3126P11	Porcelain: 8.2 pF ±5%, 500 VDCW; sim to 8R2CT500X. (Used in G3).
C58	344A3126P15	Porcelain: 12 pF ±5%, 500 VDCW; sim to 120JT500X. (Used in G6, G7, G8 and G11).
C58	344A3126P7	Porcelain: 5.6 pF ±0.25%, 500 VDCW; sim to 5R6CT500X. (Used in G9, G10).
C59	19A702061P49	Ceramic: 56 pF ±5%, 50 VDCW, temp coef 0 ±30 PPM.
C60	19A702061P65	Ceramic: 150 pF ±5%, 50 VDCW, temp coef 0 ±30 PPM°C.
C61	19A702061P17	Ceramic: 12 pF ±10 pF, 50 VDCW, temp coef 0 ±30 PPM°C.
C62	19A702061P5	Ceramic: 2.2 pF ±0.5 pF, 50 VDCW, temp coef 0 ±120 PPM.
C64	344A3126P38	Porcelain: 100 pF ±5%, 500 VDCW; sim to 101JT500X.
C65	344A3126P11	Porcelain: 8.2 pF ±5%, 500 VDCW; sim to 8R2CT500X. (Used in G3).
C65	344A3126P5	Porcelain: 4.7 pF ±0.25%, 500 VDCW; sim to 4R7CT500X. (Used in G9, G10).
C66	19A700006P58	Mica/teflon: 47 pF ±2%, 100 VDCW. (Used in G8).
C66	19A700006P55	Mica/teflon: 27 pF ±2%, 100 VDCW. (Used in G9 and G10).
C66	19A700006P50	Mica/teflon: 39 pF ±2%, 100 VDCW. (Used in G6, G7, and G11).
C66	19A700006P48	Mica/teflon: 33 pF ±2%, 100 VDCW. (Used in G3).

SYMBOL	PART NUMBER	DESCRIPTION
C67	19A700006P58	Mica/teflon: 47 pF ±2%, 100 VDCW(G6).
C67	19A700006P50	Mica/teflon: 39 pF ±2%, 100 VDCW. (Used in G7, G8, and G11).
C67	19A700006P49	Mica/teflon: 36 pF ±2%, 100 VDCW (G3).
C67	19A700006P55	Mica/teflon: 27 pF ±2%, 100 VDCW. (Used in G9 and G10).
C68	19A700006P58	Mica/teflon: 47 pF ±2%, 100 VDCW. (Used in G8 and G11).
C68	19A700006P50	Mica/teflon: 39 pF ±2%, 100 VDCW. (Used in G6, G7, and G11).
C68	19A700006P48	Mica/teflon: 33 pF ±2%, 100 VDCW (G3).
C68	19A700006P55	Mica/teflon: 27 pF ±2%, 100 VDCW. (Used in G9 and G10).
C69	19A700006P49	Mica/teflon: 36 pF ±2%, 100 VDCW (G3).
C69	19A700006P58	Mica/teflon: 47 pF ±2%, 100 VDCW. (Used in G8 and G11).
C69	19A700006P50	Mica/teflon: 39 pF ±2%, 100 VDCW (G7).
C69	19A700006P55	Mica/teflon: 27 pF ±2%, 100 VDCW. (Used in G9 and G10).
C69	19A700006P57	Mica/teflon: 43 pF ±2%, 100 VDCW. (Used in G8).
C70	19A702061P49	Ceramic: 56 pF ±5%, 50 VDCW, temp coef 0 ±30 PPM.
C71	19A702061P63	Ceramic: 120 pF ±5%, 50 VDCW, temp coef 0 ±30 PPM.
C72 and C73	19A702052P26	Ceramic: 0.1 uF ±10%, 50 VDCW.
C75 thru C77	19A702052P26	Ceramic: 0.1 uF ±10%, 50 VDCW.
C78 and C79	19A705205P7	Tantalum: 10 uF, 25 VDCW; sim to Sprague 293D.
C81	344A3126P62	Porcelain: 1000 pF ±5%, 500 VDCW; sim to 102JT500X.
C82 and C83	19A705108P40	Mica chip: 120 pF, ±5%, 100 VDCW, temp coef 0 ±50 PPM°C.
C84	19A702061P89	Ceramic: 1500 pF ±5%, 50 VDCW, temp coef 0 ±30 PPM.
C85 and C86	19A705108P40	Mica chip: 120 pF, ±5%, 100 VDCW, temp coef 0 ±50 PPM°C.
C87	19A700006P60	Mica/teflon: 56 pF ±2%, 100 VDCW. (Used in G8).
C87	19A700006P58	Mica/teflon: 47 pF ±2%, 100 VDCW. (Used in G6, and G11).
C87	19A700006P57	Mica/teflon: 43 pF ±2%, 100 VDCW. (Used in G7).
C87	19A700006P50	Mica/teflon: 39 pF ±2%, 100 VDCW. (Used in G3).
C87	19A700006P48	Mica/teflon: 33 pF ±2%, 100 VDCW. (Used in G9 and G10).
C88	19A700006P59	Mica/teflon: 51 pF ±2%, 100 VDCW. (Used in G6, G8, and G11).
C88	19A700006P57	Mica/teflon: 43 pF ±2%, 100 VDCW. (Used in G7).
C88	19A700006P50	Mica/teflon: 39 pF ±2%, 100 VDCW. (Used in G3).
C88	19A700006P48	Mica/teflon: 33 pF ±2%, 100 VDCW. (Used in G9 and G10).
C89	19A700006P59	Mica/teflon: 51 ohms ±2%, 100 VDCW. (Used in G6, G8, and G11).
C89	19A700006P57	Mica/teflon: 43 pF ±2%, 100 VDCW. (Used in G7).
C89	19A700006P50	Mica/teflon: 39 pF ±2%, 100 VDCW. (Used in G3).

SYMBOL	PART NUMBER	DESCRIPTION
C89	19A700006P48	Mica/teflon: 33 pF ±2%, 100 VDCW. (Used in G9 and G10).
C90	19A700006P60	Mica/teflon: 56 pF ±2%, 100 VDCW. (Used in G8).
C90	19A700006P58	Mica/teflon: 47 pF ±2%, 100 VDCW. (Used in G6 and G11).
C90	19A700006P57	Mica/teflon: 43 pF ±2%, 100 VDCW. (Used in G7).
C90	19A700006P50	Mica/teflon: 39 pF ±2%, 100 VDCW. (Used in G3).
C90	19A700006P48	Mica/teflon: 33 pF ±2%, 100 VDCW. (Used in G9 and G10).
C91	19A700006P57	Mica/teflon: 43 pF ±2%, 100 VDCW. (Used in G8).
C91	19A700006P58	Mica/teflon: 47 pF ±2%, 100 VDCW. (Used in G9 and G11).
C91	19A700006P49	Mica/teflon: 36 pF ±2%, 100 VDCW. (Used in G7).
C91	19A700006P48	Mica/teflon: 33 pF ±2%, 100 VDCW. (Used in G3, G9 and G10).
C92	19A700006P59	Mica/teflon:(Used in G8).
C92	19A700006P57	Mica/teflon: 43 pF ±2%, 100 VDCW. (Used in G6 and G11).
C92	19A700006P50	Mica/teflon: 39 pF ±2%, 100 VDCW. (Used in G7).
C92	19A700006P48	Mica/teflon: 33 pF ±2%, 100 VDCW. (Used in G3).
C92	19A700006P55	Mica/teflon: 27 pF ±2%, 100 VDCW. (Used in G9 and G10).
C93	19A700006P59	Mica/teflon: 51 ohms ±2%, 100 VDCW. (Used in G8).
C93	19A700006P57	Mica/teflon: 43 pF ±2%, 100 VDCW. (Used in G6 and G11).
C93	19A700006P50	Mica/teflon: 39 pF ±2%, 100 VDCW. (Used in G7).
C93	19A700006P48	Mica/teflon: 33 pF ±2%, 100 VDCW. (Used in G3).
C93	19A700006P55	Mica/teflon: 27 pF ±2%, 100 VDCW. (Used in G9 and G10).
C94	19A700006P57	Mica/teflon: 43 pF ±2%, 100 VDCW. (Used in G8).
C94	19A700006P49	Mica/teflon: 36 pF ±2%, 100 VDCW (G7).
C94	19A700006P58	Mica/teflon: 47 pF ±2%, 100 VDCW. (Used in G6 and G11).
C94	19A700006P48	Mica/teflon: 33 pF ±2%, 100 VDCW. (Used in G3, G9, and G10).
		----- DIODES -----
D1 thru D3	19A705377P4	Silicon: Hot Carrier; sim to HP HSMS-2802.
D4 thru D6	19A700053P3	Silicon: 2 Diodes in Series, Common Cathode; sim to M8AV70L.
		----- JACKS -----
J101	19A705512P1	Connector, RF SMB Series: sim to AMP No. 221111-1.
J103	19A134263P1	Contact, electrical: sim to Selectro 229-1082-00-0-590.
J104	7777145P5	Receptacle: sim to Amphenol 82-97.
J201	19A704852P32	Printed wire, two part: 6 contacts, sim to Molex 22-29-2061.
		----- INDUCTORS -----
L1	19C320617P10	Coil.
L2	19A701091G1	Coil (Used in G6, G7, G8 and G11).
L3	19C320617P10	Coil (Used in G6, G7, G8 and G11).
L4	19C320617P28	Coil.
L5	19A701091G1	Coil (Used in G6, G7, G8 and G11).
L6	19C320617P10	Coil (Used in G6, G7, G8 and G11).

PARTS LIST

LBI-38674

SYMBOL	PART NUMBER	DESCRIPTION
L7	19A705470P3	Coil, Fixed: 15 nH; sim to Toko 380NB-15nM.
L8	19A705470P8	Coil, Fixed: 39 nH; sim to Toko 380NB-39nM.
L14	19C320617P17	Coil.
L15 thru L17	19A700024P13	Coil, RF: 1.0 μH ±20%.
L18	19C320617P17	Coil.
L23	19A705470P8	Coil, Fixed: 39 nH; sim to Toko 380NB-39nM.
L24	19A705470P1	Coil, Fixed: 10 nH; sim to Toko 380NB-15nM.
L25	19A701091G1	Coil.
L29 and L30	19C320617P10	Coil.
----- TRANSISTORS -----		
Q1	344A3948P1	Silicon, NPN: 440-512 MHz, 50W; sim to MRF 650.
Q2 and Q3	344A4134P1	Silicon, NPN: 470-512 MHz, 65W; sim to MRF 658.
Q4 and Q5	19A700076P2	Silicon, NPN: sim to MMBT3904, low profile.
Q7	19A701940P1	Silicon, NPN: sim to MRF 559.
Q7	344A3058P1	Silicon, NPN.
Q203	19A700055P1	Silicon, PNP.
----- RESISTORS -----		
R1 and R2	19B800607P270	Metal film: 27 ohms ±5%, 1/8 w.
R3 thru R6	19B801486P101	Metal film: 100 ohms ±5%, 1/2 w.
R7	19B800607P183	Metal film: 18K ohms ±5%, 1/8 w.
R8 thru R10	19B800607P103	Metal film: 10K ohms ±5%, 1/8 w.
R11	19B800607P223	Metal film: 22K ohms ±5%, 1/8 w.
R12 thru R18	19B800607P103	Metal film: 10K ohms ±5%, 1/8 w.
R19 and R20	19B800607P472	Metal film: 4.7K ohms ±5%, 1/8 w.
R21 thru R23	19B800607P102	Metal film: 1K ohms ±5%, 1/8 w.
R24 thru R26	19B800607P103	Metal film: 10K ohms ±5%, 1/8 w.
R27	19B800607P822	Metal film: 8.2K ohms ±5%, 1/8 w.
R28 and R29	19A143832P6	Power: 100 ohms ±5%, 40 w.
R30	19B800607P750	Metal film: 75 ohms ±5%, 1/8 w.
R31	19B800607P330	Metal film: 33 ohms ±5%, 1/8 w.
R32	19A700050P17	Wirewound: 2.2 ohms ±10%, 2 w. (Used in G3, G9, and G10).
R33	19B800607P153	Metal film: 1.5K ohms ±5%, 1/8 w.
R34	19B801486P100	Metal film: 10 ohms ±5%, 1/2 w.
R35	19A700050P17	Wirewound: 2.2 ohms ±10%, 2 w. (Used in G3, G9, and G10).
R36	19B801486P101	Metal film: 100 ohms ±5%, 1/2 w. (Used in G40, G3, and G6).
R37	19B801486P331	Metal film: 330 ohms ±5%, 1/2 w.
R38	19B800607P223	Metal film: 22K ohms ±5%, 1/8 w.

SYMBOL	PART NUMBER	DESCRIPTION
R39 and R40	19B800607P100	Metal film: 10 ohms ±5%, 1/8 w.
R41	19A702931P333	Metal film: 21.5K ohms ±1%, 200 VDCW, 1/8 w.
R42	19A702931P293	Metal film: 9090 ohms ±1%, 200 VDCW, 1/8 w.
R43	19A700109P5	Variable, cermet: 25 ohms to 10K ohms ±20%, 1/4 w.
R44 thru R46	19B801486P101	Metal film: 100 ohms ±5%, 1/2 w.
R47 and R48	19B801486P750	Metal film: 75 ohms ±5%, 1/2 w.
R49	19B801486P101	Metal film: 100 ohms ±5%, 1/2 w.
R50	19B800607P1	Metal film: Jumper. (Used in G8, G9, G10 and G11).
R51	19B801486P331	Metal film: 330 ohms ±5%, 1/2 w.
R52	19B801486P100	Metal film: 10 ohms ±5%, 1/2 w.
R53	19B800607P1	Metal film: Jumper.
R54	19B800607P472	Metal film: 4.7 ohms ±5%, 1/8 w.
R55	19B800607P103	Metal film: 10K ohms ±5%, 1/8 w.
----- THERMISTOR -----		
RT1	19A705813P2	Thermistor: sim to AL03006-58.2K-97-G100.
----- VOLTAGE REGULATORS -----		
VR1 and VR2	19A700083P102	Silicon: 5.1 Volt Zener; sim to BZX84-C5V1.
----- CAPACITORS -----		
C1	19A116708P2	Ceramic feedthru: 0.01 μF -0 +100%, 500 VDCW; sim to Erie 327-050-X5W0103P.
----- JACKS -----		
J1		Part of W1.
J104	7777145P5	Receptacle: sim to Amphenol 82-97.
----- TRANSISTORS -----		
Q1	344A3948P1	Silicon, NPN: UHF Amplifier; sim to Motorola MRF 650.
Q2 and Q3	344A4134P1	Silicon, NPN: UHF Amplifier.
Q203	19A700055P1	Silicon, PNP: Darlington; sim to TIP-125.
----- RESISTORS -----		
R28 and R29	19A143832P6	Power: 100 ohm 5%, 40 w.
----- INTEGRATED CIRCUITS -----		
U1	19A705457P2	PA module: 440-470 MHz; sim to M57704H. (Used in G3).
U1	19A705457P1	PA module: 400-450 MHz; sim to M57704M. (Used in G7).
U1	19A705457P3	PA module: 470-512 MHz; sim to M57704SH. (Used in G9).
U1	19A705457P7	PA module: 380-400 MHz; sim to M57704UL. (Used in G8).
U1	19A705457P4	PA module: 400-420 MHz; sim to M57704L. (Used in G6 and G10).
U2	19A702293P3	Linear: Dual Op Amp; sim to LM358D.
U3	19A701789P4	Linear: Quad Op Amp; sim to LM224D.
U7	344A3907P1	Monolithic microwave IC (MMIC): sim to AvanteK MSA-1105.
U100	19A705532P2	Integrated Circuit, Linear (Positive Voltage Regulator): sim to MC78T15CT.

SYMBOL	PART NUMBER	DESCRIPTION
----- CABLES -----		
W1	19B801529G4 19B800560P2 19A705512P3	RF Input Cable. Includes the following: RF Cable. Connector, RF SMB series: sim to AMP 228213-1.
	19A115938P1	Connector, coaxial: (BNC Series); sim to Amphenol 31-318.
W4	19B801695G11 19B209268P115 19B209260P11 19A115959P2 19A701503P2 19A701503P10 19B209268P116	Power Cable. Includes the following: Solderless terminal. Solderless terminal. Wire, stranded. Cable: battery, red. Cable: battery, black. Solderless terminal.
W10	19B801937P1	Power cable.
W13	19B801739P1	Power control cable.
----- MISCELLANEOUS -----		
2	19D902420P6	Heatsink.
5	19A702381P510	Screw, thread forming: TORX DRIVE No. M3.5 0.6 x 10.
6	7139898P3	Nut, hex, brass: No. 1/4-28.
11	19A702364P310	Machine screw, TORX Drive: No. M3-0.5 x 10.
14	19B209268P113	Terminal, solderless: sim to AMP 2-34835-4. (Used in G11).
	19A115959P2 19B209268P116	Wire, stranded. (Used in G11). Solderless terminal. (Used in G11).
16	19A700136P7	Insulated sleeving.
21	19A701863P27	Clip, loop.
22	19A701312P5	Flatwasher: M3.5.
28	19A702364P316	Machine Screw: Pan Head, Steel.
29	19A700034P4	Nut, hex: No. M3 x 0.5MM.
30	19A700033P5	Lock washer, external tooth: No. 3.
35	19A705469P1	Insulator Plate, TO-220.
36	19A700068P1	Insulator, bushing.
37	19A134455P3	Flat washer.
38	19B801659G3	Cover (see separate parts list).
41	19A700033P6	Loackwasher, external tooth, M3.5.
45	N405P5B6	Lockwasher.
46	19A701312P4	Flatwasher: 3.2 ID.
50	19A702381P408	Tap screw, TORX Drive, M3-0.5 x 8.
51	19A705106P1	Resistor Spacer.
COVER 19B801659G3		
2	19D902421P1	Power Amplifier Cover.
4	19A702381P522	Screw, thread forming:
5	19A701365P4	Washer.
11	19A149969P3	Shield.
13	5493477P9	Axial fan.
14	5493477P10	Grille.
15	N80P13028B6	Machine screw.
16	N210P21B6	Machine nut.
17	19A701312P5	Flatwasher: M3.5.
18	19A701863P10	Clip, loop.
20	19A702364P410	Machine screw.
24	N405P37B6	Lock washer.
25	L401P23B6	Split washer.
26	19A700034P5	Hex nut.

LOW PASS FILTER MODULE 19D902856G3 & G9 ISSUE 2		
SYMBOL	PART NUMBER	DESCRIPTION
----- JACKS -----		
J1 and J2	7777145P5	Receptacle: sim to Amphenol 82-97.
----- MISCELLANEOUS -----		
2	19D903063P1	Casting.
3	19D903064P1	Casting.
5	19A702381P513	Screw, thread forming: TORX, No. M3.5 - 0.6 X 13.
6	19A702364P210	Machine screw, metric: M2.5-45 x 10.
7	19A134455P3	Flatwasher.
8	19A700032P3	Lockwasher, tooth, steel, metric: 2.5.
UHF FILTER BOARD 19D902853G3		
----- CAPACITORS -----		
C1 thru C3	19A700006P2	Mica: 5.6 pF ±10%, 100 VDCW; sim to Underwood 3HS0020.
C4	19A700006P1	Mica: 4.7 pF ±10%, 100VDCW.
C5	19A700006P2	Mica: 5.6 pF ±10%, 100 VDCW; sim to Underwood 3HS0020.
----- INDUCTORS -----		
L1 and L2	19C320618P7	Coil.
L3 thru L6	19B227929P1	Coil.
UHF FILTER BOARD 19D902853G9		
----- CAPACITORS -----		
C1	19A700006P1	Mica: 4.7 pF ±10%, 100 VDCW.
C2 and C3	19A700006P3	Mica: 6.8 pF ±10%, 100VDCW.
----- INDUCTORS -----		
L1 thru L4	19C320617P17	Coil.
----- MISCELLANEOUS -----		
11	19A702455P5	Nut, self clinching.

* COMPONENTS, ADDED, DELETED OR CHANGED BY PRODUCTION CHANGES

PRODUCTION CHANGES

Changes in the equipment to improve performance or to simplify circuits are identified by a "Revision Letter" which is stamped after the model number of the unit. The revision stamped on the unit includes all previous revisions. Refer to the Parts List for the descriptions of parts affected by these revisions.

COMPONENT SIDE

PRODUCTION CHANGES

REV. A **POWER AMPLIFIER 19D902797G3**
POWER AMPLIFIER BOARD 19D902794G3

To make unit ETS compliant.
C17, C44, C45 were 19A702052P33.
C50 was 0.068 μ F (19A702052P24).
C61 was 8.2 pF (19A702061P12).
C62 was 27 pF (19A702061P33).
C84 was 1000 pF (19A705108P40).
D1, D2, D3 were (19A700047P3).
L15 thru L17 were (19A700024P37).
L24 was 15nH (19A705470P3).
R33 was 5.6K (19B800607P562).
R34 was 3.9 ohms composition (19A700113P5).
L26 and L27 were removed.
C48, C49, C63, C74 were removed.
C1, (19A702052P26) was added.
C25, C26 (344A3126P38) were added.
R37, R51 (19B801486P331) were added.
R52 (19B801486P100) was added.
Q7 was 19A701940P1.
RT1 (19A705813P2) was added.
VR2 (19A700083P102) was added.

REV. B **POWER AMPLIFIER 19D902797G3**
POWER AMPLIFIER BOARD 19D902794G3

To update PWB for new split.
PWB changed
C26 was 100 pF (344A3126P38).
C81 was 100 pF (344A3126P38).
C27 thru C29 added: 8.2 pF (344A3126P11).
C34 and C35 added: 12 pF (344A3126P15).
R36 was 150 ohms (19B801486P151).
R44 thru R46 were 150 ohm (19B801486P151).
R47 and R48 were 39 ohm (19B801486P390).
R32 and R35 added: 2.2 ohm (19A700050P17).

REV. C **POWER AMPLIFIER 19D902797G3**
POWER AMPLIFIER BOARD 19D902794G3

To update PWB for new band splits.

REV. D **POWER AMPLIFIER 19D902797G3**
POWER AMPLIFIER BOARD 19D902794G3

To update PWB for new band splits and add power monitor circuitry.
Added U2, C48, R54, R53, R55.

REV. A **POWER AMPLIFIER 19D902797G6**

To update PWB to new band splits.

REV. A **POWER AMPLIFIER 19D902797G7**
POWER AMPLIFIER BOARD 19D902794G7

To update PWB to new band splits and add power monitor circuitry.
Added U2, C48, R54, R53, R55.

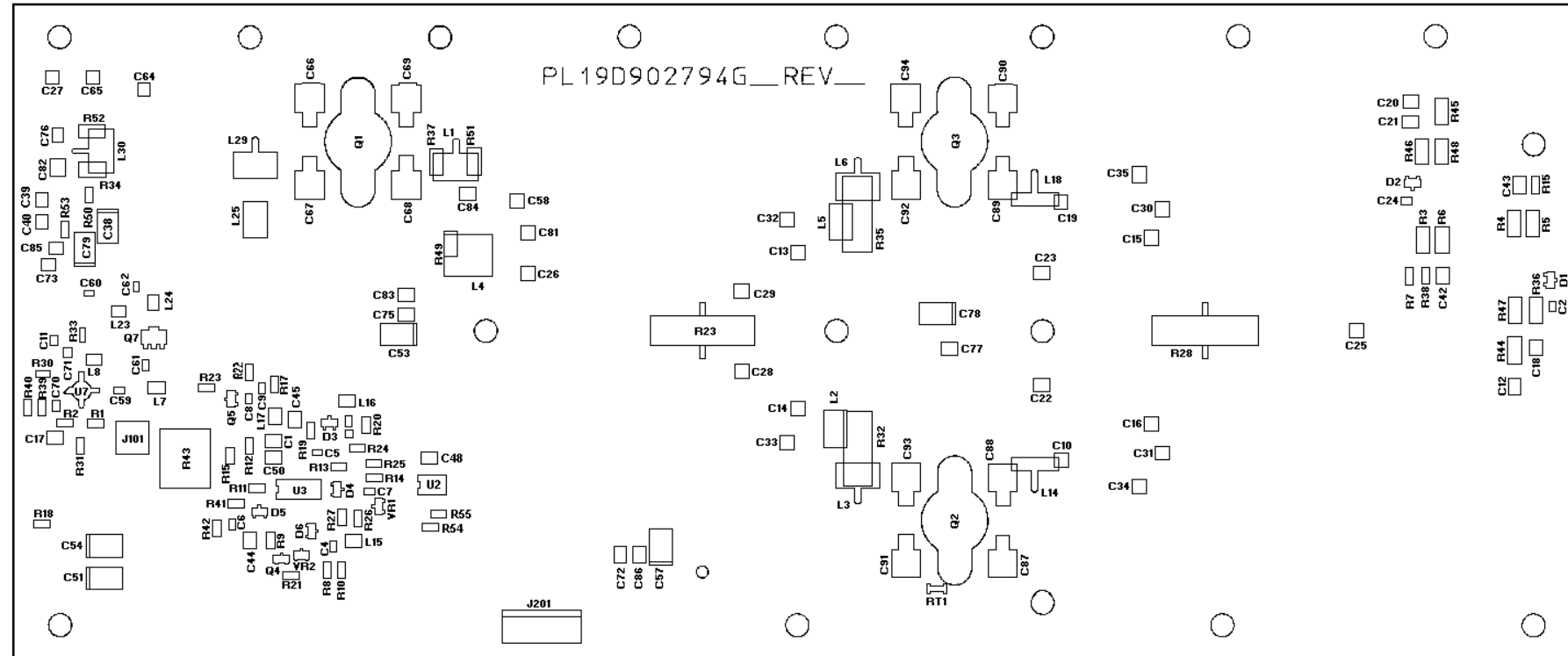

(19D902794, Sh. 2, Rev. 5)

LEAD IDENTIFICATION FOR
Q4, Q5, Q7
(SOT) TRANSISTORS
(TOP VIEW)

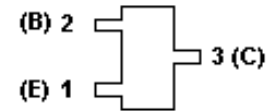

LEAD IDENTIFICATION FOR U7
4 GND

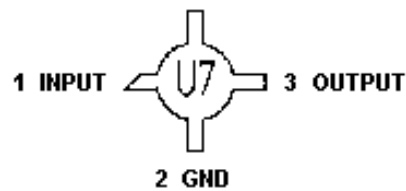

LEAD IDENTIFICATION FOR
D4, D5, D6, VR1
(SOT) DIODES
(TOP VIEW)

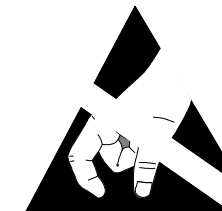

CAUTION

OBSERVE PRECAUTIONS
FOR HANDLING

ELECTROSTATIC
SENSITIVE
DEVICES

POWER AMPLIFIER BOARD A1
19D902856G3, G6, G7, G8, G9, G10 & G11

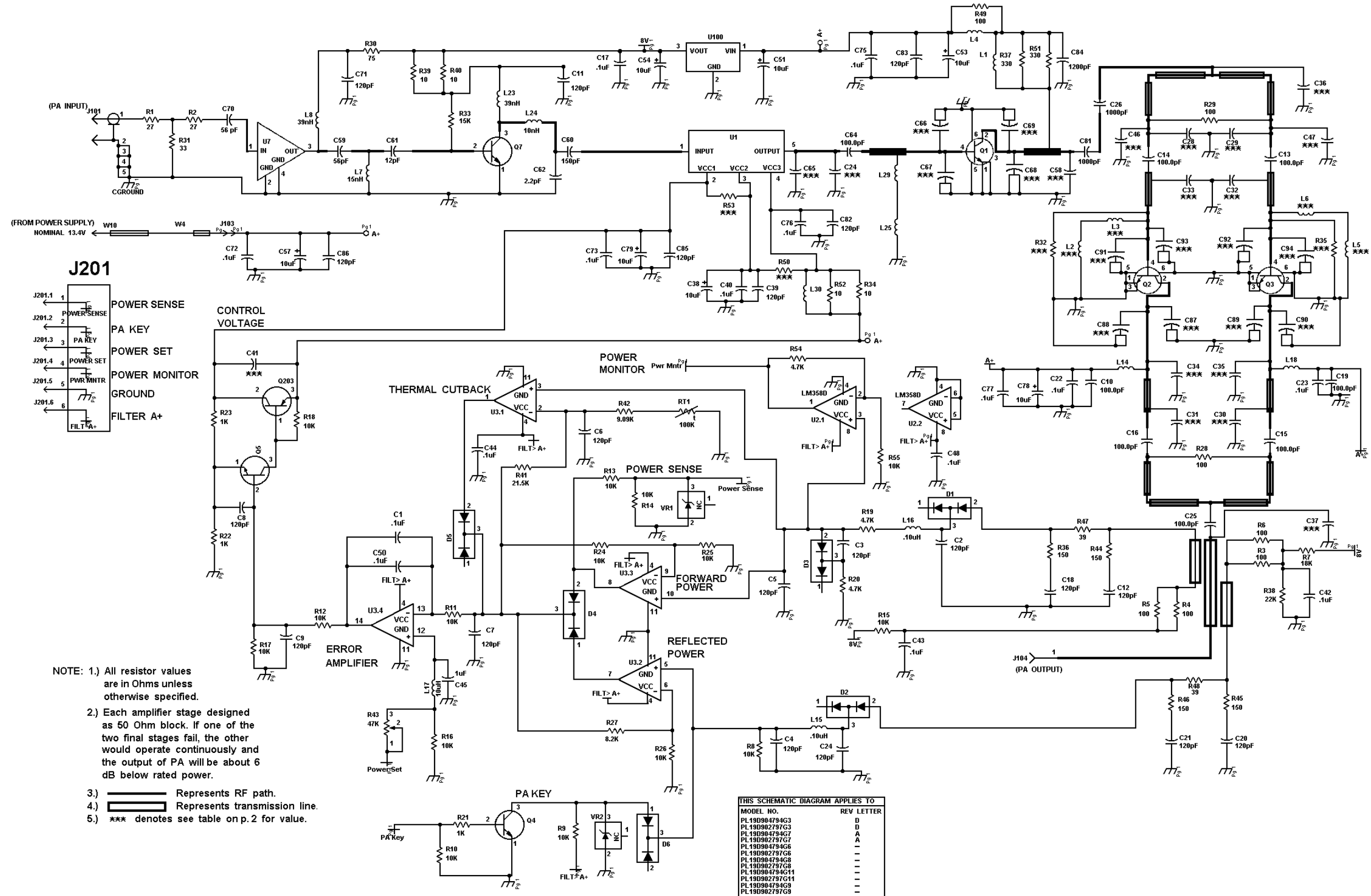

POWER AMPLIFIER ASSEMBLY
19D902797G3, G6, G7, G8, G9, G10 & G11

(19D903622 Sh.1 Rev.7)

TABLE I

REF. DES.	380-400 MHz	403-425 MHz	425-450 MHz	450-470 MHz	470-494 MHz	492-512 MHz	410-430 MHz
C27	10.0 pf	12.0 pf	10.0 pf	not used	not used	N/A	12.0 pf
C28	15.0 pf	12.0 pf	8.2 pf	not used	not used	N/A	10.0 pf
C29	15.0 pf	12.0 pf	8.2 pf	not used	not used	N/A	10.0 pf
C30	12.0 pf	not used	not used	8.2 pf	8.2 pf	N/A	not used
C31	12.0 pf	not used	not used	8.2 pf	8.2 pf	N/A	not used
C32	not used	not used	not used	3.3 pf	not used	N/A	not used
C33	not used	not used	not used	3.3 pf	not used	N/A	not used
C34	not used	15.0 pf	15.0 pf	not used	not used	N/A	15.0 pf
C35	not used	15.0 pf	15.0 pf	not used	not used	N/A	15.0 pf
C36	3.9 pf	4.7 pf	not used	not used	not used	N/A	4.7 pf
C58	12.0 pf	12.0 pf	12.0 pf	8.2 pf	5.6 pf	N/A	12.0 pf
C65	not used	not used	not used	8.2 pf	4.7 pf	N/A	not used
C66	47.0 pf	39.0 pf	39.0 pf	33.0 pf	27.0 pf	N/A	39.0 pf
C67	47.0 pf	47.0 pf	39.0 pf	36.0 pf	27.0 pf	N/A	39.0 pf
C68	47.0 pf	39.0 pf	39.0 pf	33.0 pf	27.0 pf	N/A	39.0 pf
C69	47.0 pf	47.0 pf	39.0 pf	36.0 pf	27.0 pf	N/A	43.0 pf
C87	56.0 pf	47.0 pf	43.0 pf	39.0 pf	33.0 pf	N/A	47.0 pf
C88	51.0 pf	51.0 pf	43.0 pf	39.0 pf	33.0 pf	N/A	51.0 pf
C89	51.0 pf	51.0 pf	43.0 pf	39.0 pf	33.0 pf	N/A	51.0 pf
C90	56.0 pf	47.0 pf	43.0 pf	39.0 pf	33.0 pf	N/A	47.0 pf
C91	51.0 pf	47.0 pf	36.0 pf	33.0 pf	33.0 pf	N/A	43.0 pf
C92	51.0 pf	43.0 pf	39.0 pf	33.0 pf	27.0 pf	N/A	43.0 pf
C93	51.0 pf	43.0 pf	39.0 pf	33.0 pf	33.0 pf	N/A	43.0 pf
C94	51.0 pf	47.0 pf	36.0 pf	33.0 pf	27.0 pf	N/A	43.0 pf
L2	BEAD	BEAD	BEAD	not used	not used	N/A	BEAD
L3	AIR COIL	AIR COIL	AIR COIL	not used	not used	N/A	AIR COIL
L5	BEAD	BEAD	BEAD	not used	not used	N/A	BEAD
L6	AIR COIL	AIR COIL	AIR COIL	not used	not used	N/A	AIR COIL
R32	not used	not used	not used	2.2	2.2	N/A	not used
R35	not used	not used	not used	2.2	2.2	N/A	not used
C37	2.2 pf	not used	not used	not used	not used	N/A	not used
R53	not used	0	0	0	not used	N/A	not used
R50	0	not used	not used	not used	0	N/A	0
C41	not used	not used	not used	not used	not used	N/A	100.0 pf
C46	not used	not used	not used	not used	8.2	N/A	not used
C47	not used	not used	not used	not used	8.2	N/A	not used

COMPONENT SIDE

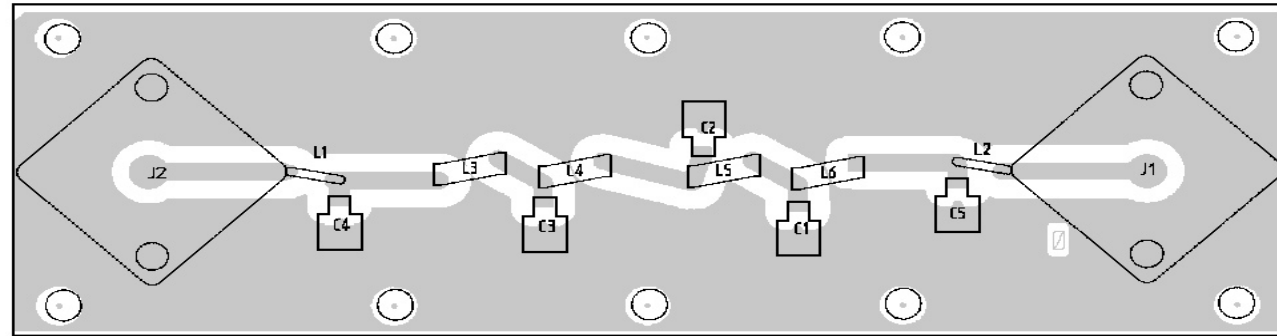

(19D902853, Sh. 2, Rev. 0)
(19D903638, Component Side, Rev. 0)

SOLDER SIDE

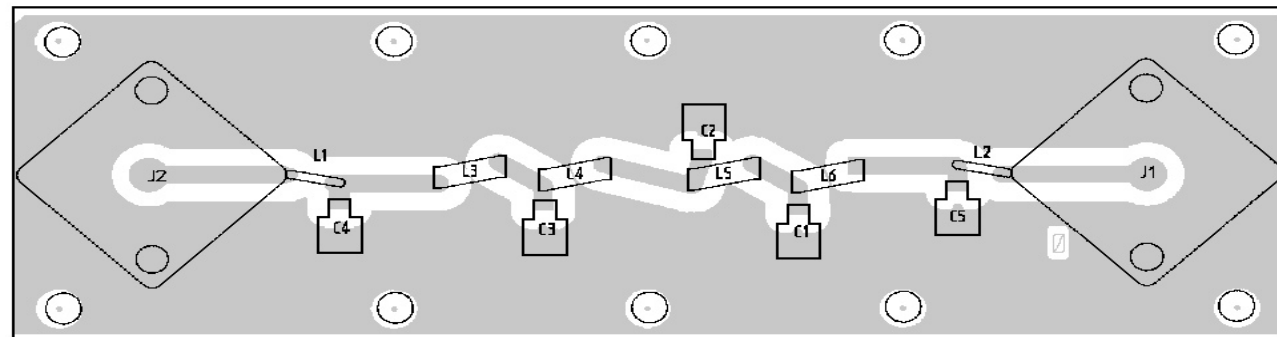

(19D902853, Sh. 2, Rev. 0)
(19D903638, Solder Side, Rev. 0)

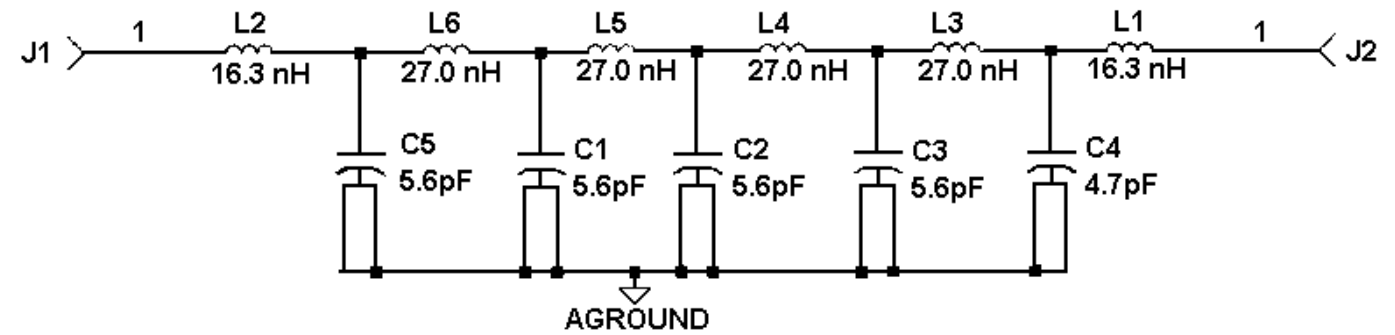

POWER AMPLIFIER ASSEMBLY
19D902797G3, G6, G7, G8, G9, G10 & G11

(19D903622 Sh.2 Rev. 7)

LOW PASS FILTER MODULE
19D902856G3

(19D903623 Sh.1 Rev. 1)

U1
19A705457P1, P2 AND P4
PA Amplifier Module

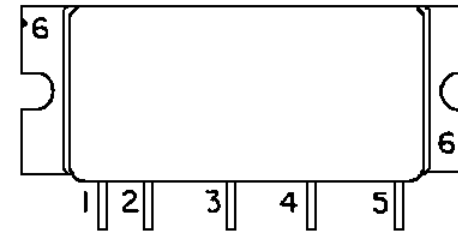

- 1. P_{in}
- 2. V_{cc1} - 1ST STAGE
- 3. V_{cc} - 2ND STAGE
- 4. V_{cc} - OUTPUT STAGE
- 5. P_{out}
- 6. FIN - GROUND

U100
19A705532P2
Voltage Regulator

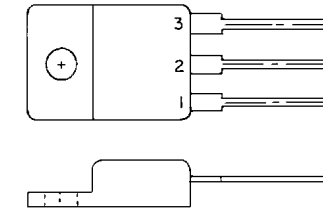

- PIN 1 ADJUST PIN
- PIN 2 OUTPUT
- PIN 3 INPUT

U7
344A3907P1
MMIC Amplifier

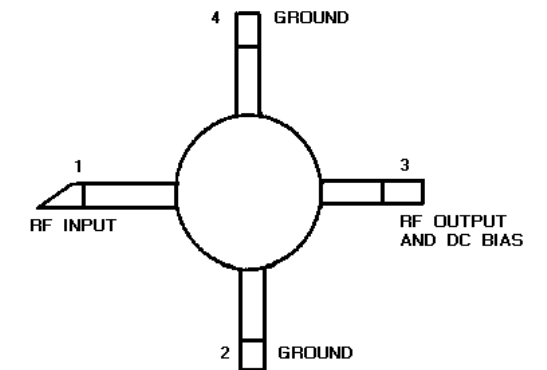

U3
19A701789P4
Quad Op-Amp

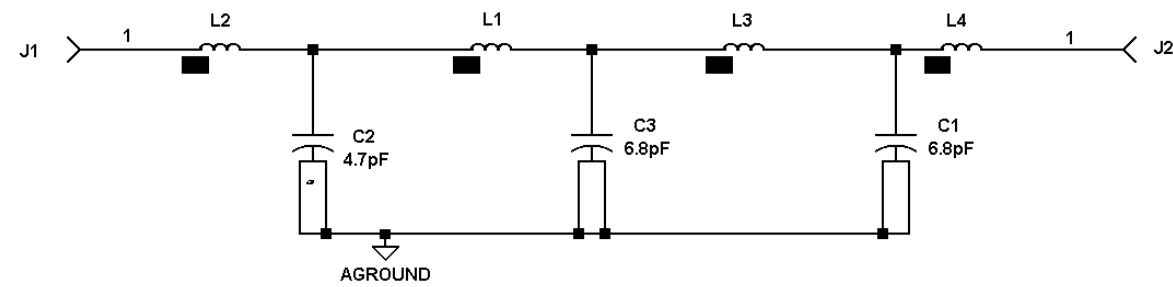
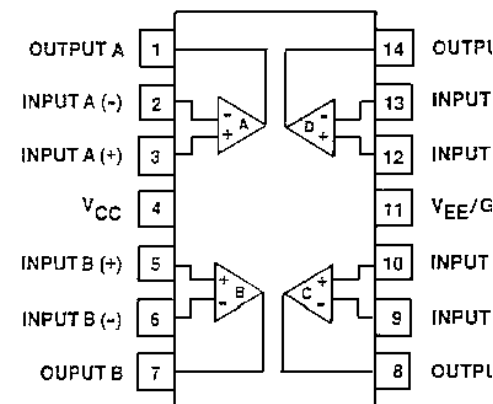

LOW PASS FILTER MODULE
470 - 512 MHz
19D902856G9

(19B804157, Rev.0)