



Mobile Communications

MDR™
MOBILE RADIO

TABLE OF CONTENTS

DUPLEXER INTERFACE BOARD	LBI-38700
RF BOARD	LBI-38697
SYSTEM BOARD	LBI-31924
LOGIC BOARD	LBI-38392
AUDIO BOARD	LBI-38391
FRONT CAP ASSEMBLY	LBI-38699
HANDSET	LBI-38698
SERVICE SECTION	LBI-38701



Ericsson GE Mobile Communications Inc.
Mountain View Road • Lynchburg, Virginia 24502

Printed in U.S.A.

TABLE OF CONTENTS

	<u>Page</u>
SPECIFICATIONS	2
GENERAL DESCRIPTION	2
RF BOARD	2
Synthesizer circuit	2
Transmitter Circuit	2
Receiver Circuit	2
DUPLEXER INTERFACE/TALK-AROUND BOARD	3
AUDIO BOARD	3
LOGIC BOARD	3
SYSTEM BOARD	3
FRONT CAP ASSEMBLY	3
ACCESSORIES AND OPTIONS	3
PC PROGRAMMER OPTIONS	3
PC PROGRAMMED OPTIONS	3
Carrier Control Timer (CTT)	3
Channel Guard	3
Squelch Tail Elimination (STE)	3
Hook Switch Programming Option	3
Retry Option	4
HARDWARE AND HARDWARE OPTIONS	4
HANDSET	4
HANDSET CABLING OPTIONS	4
OPTION CABLE	4
NOISE SUPPRESSION KIT OPTION	4
POWER CABLE OPTION	4
EXTERNAL SPEAKER OPTION	4
EXTERNAL ALARM	4
SYSTEM DESCRIPTION	4
OPERATIONAL MODES	4
IDLE MODE	4
WAIT MODE	5
READY MODE	5
GLOSSARY OF SYSTEM TERMS	5
RADIO OPERATION	7
VISUAL INDICATORS	7
ALPHA NUMERIC STATUS INDICATORS	7
Busy	7
Retrying	7
Wait	7

TABLE OF CONTENTS (Cont'd)

	<u>Page</u>
STATUS INDICATORS	7
No Service	7
Roam	7
Function	7
In Use	7
Bar Status Indicators ()	7
Horn	7
Mute	7
Lock	7
AUDIBLE INDICATORS	7
SELF CHECK TEST ALERT	7
CALL RECEIVED ALERT	7
CALL ORIGINATE ALERT	7
SYSTEM BUSY	7
OUT OF RANGE ALERT	7
INVLAID CALL ORIGINATE ALERT	7
CARRIER CONTROL TIMER	7
GE-MARC SYSTEM TONES	7
KEY DEFINITIONS/FUNCTIONS	8
MISCELLANEOUS KEYS	8
Power	8
Push-To-Talk	8
Volume Up	8
Volume Down	8
FUNCTION KEYPAD	8
Send	8
Clear (CLR)	8
End	8
Recall (RCL)	8
Store (STO)	8
Alphabet Keys (A, B, C)	8
Function (FCN)	8
NUMERIC KEYPAD	8
0-9	8
Asterisk (*)	8
Pound (#)	8
TELEPHONE EXTENDED FEATURES	8

TABLE OF CONTENTS (Cont'd)

	<u>Page</u>
BASIC OPERATION	8
VOLUME ADJUSTMENT	8
AREA SELECTION	9
GROUP SELECTION	9
CHANNEL ACTIVITY	9
PLACING A DISPATCH CALL	9
PLACING AN INTERCONNECT OR DISPATCH OVERDIAL CALL	9
ENDING A CALL	9
RECEIVING A CALL	9
DIRECT MODE OPERATION	9
CONVENTIONAL MODE OPERATION	9
Call Timer	9
Last Digit Clear And Display Clear	9
Storing Numbers	9
Recalling Numbers	10
Hotkeys	10
Last Number Redial	10
Unlocking The Mobile	10
Locking The MRD Mobile Radio	10
Backlight	10
Horn	10
External Speaker	10
Call Hold (Mute)	10
Simplex Operation	10
DTMF Digit Length	10
Delay After DTMF Star (*)	10
CHANNEL GUARD TONE FREQUENCIES	10
DIGITAL CHANNEL GUARD CODES	10
ASSEMBLY DIAGRAM	11
PARTS LIST	11
INTERCONNECTION DIAGRAMS:	
800 MHz Duplex Mobiles (System)	12
Standard 800 MHz Duplex Mobile	13
800 MHz Duplex With Talk-Around	14
800 MHz Duplex Mobile (Options)	15
APPLICATION DIAGRAM	16

SPECIFICATIONS*

GENERAL

Operating Voltage	13.8 Volts ±20%
Battery Drain	
Receiver (13.8 Vdc)	
Off	.01 Amperes (maximum)
Squelched	.8 Amperes (maximum)
Unsquelled	1.00 Amperes (maximum at 3 Watts audio)
Transmitter (13.6 Vdc)	6.0 Amperes (maximum at 10 Watts RF)
Channel Spacing	25 kHz
Frequency Stability	±2.5 PPM (±.00025%)
Temperature Range	-30°C to +60°C (-22°F to +140°F)
Dimensions (H x W x D)	
(Less Accessories)	
Height	54mm (2.15 inches)(body)/62.5mm (2.46 inches) (nose)
Width	181.5mm (7.15 inches)
Depth	246mm (9.7 inches)
Weight	2.55 kg (5.6 pounds)
Antenna Impedance	50 Ohms

TRANSMITTER

Frequency Range	806.0125-820.9875 MHz 851.0125-865.9875 MHz (with Talk-around option only)
Output Power	10 Watts (100% duty cycle)
Audio Sensitivity	150-250m Vrms
Spurious and Harmonics	-56 dBc (below the carrier)
Audio Distortion	5% maximum @ 1000 Hz
Modulation Limiting	+5 kHz maximum
FM Hum and Noise	-45 dB
Audio Frequency Response per EIA Standards	Within +1, -3dB of a 6dB/Octave pre-amphasis curve from 300-3000 Hz.

RECEIVER

Frequency Range	851.0125-865.9875 MHz
Acceptable Frequency Displacement	±4 kHz minimum
Sensitivity (12 dB SINAD)	-113 dBm minimum in duplex
Spurious Response	70 dB minimum
Adjacent Channel Selectivity	65 dB minimum ±25.0 kHz
Intermodulation	60 dB minimum
Audio Frequency Response	Within +2, -8dB of a 6 dB/octave de-emphasis curve from 300-2700 Hz
Audio Output	3 Watts
Audio Distortion	5% maximum at 1000Hz

*These specifications are intended primarily for use by service personnel. Refer to the appropriate Specification Sheet for complete specifications.

GENERAL DESCRIPTION

The Ericsson GE-MARC VE MDR Mobile Radio is a synthesized, wideband radio that uses integrated circuits and microcomputer technology to provide high performance trunked and conventional operation. The radio provides 10 Watts of RF power output in the 806.0125-820.9875 MHz and 851.0125-865.9875 MHz bands. The receiver operates in the 851.0125-865.9875 MHz band.

All radio functions are stored in a programmable Electrically Erasable **PROM (EEPROM)**. The radio is field programmable using an IBM compatible personal computer with the following equipment:

- Serial Programming Interface Module TQ3310
- Programming Cable TQ3361
- MDR Programming Software TQ3355

With the interface equipment and software, the computer can be used to program (or re-program) customer system frequencies, Channel Guard tones and options. Selection of options is done during radio initialization using the PC programmer.

The MDR Mobile Radio assembly consists of the following circuit boards and assemblies:

- Duplexer Interface Board A4 19D903504
or
- Talk-Around Board A4 19D903507
(optional)
- RF Board A2 19D902123G18
- System Board A5 19D901891
- Logic Board A1 19D902172
- Audio Board A3 19D902188
- Handset Interface Board A9 19D903510
- Handset A8 344A3783P1
- Duplexer 19B801362P3

The circuit boards are all mounted on a main casting to provide easy access for servicing. Interconnect plugs are used to connect the boards to eliminate pinched wires and other wiring problems.

RF BOARD

The RF board includes the programmable frequency synthesizer, transmitter exciter, receiver front end and IF circuitry.

Synthesizer Circuit

The synthesizer generates all transmit and receive RF frequencies. The synthesizer frequency is controlled by the microprocessor located on the Logic Board. Frequency stability is maintained by a temperature compensated reference oscillator module. Transmit audio is processed on the Audio and Logic Boards, and applied to the RF board to modulate the VCO and TCXO.

Transmitter Circuit

The transmitter consists of a fixed-tuned exciter module, a PA module and a power control circuit. The PA module provides up to a 20-Watt output to drive the duplexer. The power control circuit controls the PA module by processing a DC feedback signal from the duplexer interface board to maintain constant output power across the band. The RF output level is internally adjustable for rated power. Thermistors in the control circuit protect the PA from overheating by reducing the power output level.

Receiver Circuit

The dual conversion receiver circuit consists of a front end section, 45 MHz first IF, a 455 kHz second IF, and FM detector. All audio processing and squelch functions are accomplished on the Audio Board.

DUPLEXER INTERFACE/ TALK-AROUND BOARD

Two versions of this board exist. The standard duplexer interface board contains only a directional coupler and the Talk-around board contains a directional coupler and RF switching circuitry to provide talk around transmit capability. Radio Power distribution is also present on this board. The directional coupler samples the duplexer output and provides a DC signal proportional to the detected power to the RF board power control circuitry.

AUDIO BOARD

The Audio Board provides analog to digital and digital to analog conversion of the receive and transmit audio for digital processing by the Logic Board. The board also contains analog audio filtering, conventional analog tone processing, and the receiver squelch.

LOGIC BOARD

The Logic Board controls the operation of the radio and digitally processes the receive and transmit audio. The board contains a microprocessor and associated memory circuits which include an EPROM for controlling the processor and a programmable "**personality**" memory (an Electrically Erasable **PROM - EEPROM**) to store customer frequencies, tones, and options. The microprocessor provides control data to the **Digital Signal Processor (DSP)**, conventional tone generation and detection, frequency data for the synthesizer, and sends and receives data to/from the handset for the LCD display and the keypad commands.

SYSTEM BOARD

The system Board controls the main input power to the radio. The handset POWER switch and the IGNITION SENSE input lead provide the necessary signals to the MOSFET switching circuit. The board also interfaces all option connections from the internal boards in the radio with the optional items outside of the radio. All external options for the radio, interconnect to the System Board through the back of the radio using an optional cable.

FRONT CAP ASSEMBLY

The front cap assembly contains the Handset interface board. The Handset interface board provides compression of the microphone audio from the handset. It also provides audio compression for the received audio from the radio to handset speaker audio and external speaker audio paths. A 3-watt power amplifier is provided on the Handset interface board to drive a 4-ohm external speaker. Separate mute control for the external speaker and handset audio are also provided.

ACCESSORIES AND OPTIONS

PC PROGRAMMER OPTIONS

The radio is programmed using an IBM compatible personal computer equipped with a RS-232 port. Option TQ3310 provides the RS-232 serial interface unit and the cable between the PC and the unit. An auxiliary power supply for the unit is also included which is not needed to program the MDR.

Option TQ3361 provides the radio programming cable between the PC interface unit and the radio microphone jack. MDR PC programming software Option TQ3355 provides both the 3.5 inch and 5.25-inch diskettes.

PC PROGRAMMED OPTIONS

Carrier Control Timer (CCT)

The Carrier Control Timer turns off the transmitter after the microphone push-to-talk (PTT) switch has been keyed for a pre-programmed time period. A pulsing alert tone will warn the operator to unkey and then rekey the PTT to continue the transmission. The timer can be programmed, using the PC programmer, to time out for 30 seconds to 7.5 minutes in 30 second increments. The timer can be enabled or disabled for each channel.

In Duplex mode a quick 2-note alert is heard at the interval of the carrier timer to let the user know that interval has elapsed.

Channel Guard

Channel Guard provides a means of restricting calls to specific radios through the use of a Continuous Tone Coded Squelch System (CTCSS), or a Continuous Digital Coded Squelch System (CDCSS). Channel Guard may be used only in the conventional mode, not in the GE-MARC trunked mode. Tone frequencies range from 67.0 Hz to 210.7 Hz in 0.1 Hz steps. There are also 83 standard PC programmable digital codes. The Channel Guard tone frequencies and codes are software programmable. Tone frequencies and digital codes cannot be mixed on the same RF frequency/channel. However, multiple channels can be programmed with the same frequency and different CG tones or DCG codes. These tone frequencies and digital codes are listed in **Table 1 - Channel Guard Tone Frequencies** and **Table 2 - Digital Channel Guard Codes** (refer to the Table Of Contents).

Squelch Tail Elimination (STE)

STE is used with tone and digital Channel Guard to eliminate squelch tails. The STE burst is transmitted when the microphone PTT is released. The receiving radio decodes the burst and mutes the receiver audio for 250ms. This mute time allows the transmission to end and to mute the squelch tail. The radio looks for STE on the received signal when the handset is either on or off-hook. The STE is enabled for transmit and/or receive by PC programming the radio's personality.

Hook Switch Programming Option

"**Off Hook Call**" originate and "**On Hook Call**" terminate can be enabled using the PC programmer. When this option is enabled placing the handset on the handset holder will terminate a call. When originating a call, the number to be called can be keyed in, or recalled from memory, and when the handset is removed from the holder the call will be initiated without

further user intervention. When placing a trunked **SPECIAL CALL** mobile to land interconnect call, the **ONHOOK CALL TERMINATE** feature can not be disabled. When hanging up on an interconnect call, it will always terminate the call and disconnect. This feature is only usable in the trucked dispatch mode.

Retry Option

If no channel is free, the radio can be programmed to activate the Call Retry state and display 'RETRYING' in the display. Retrying will cause the radio to revert to the Idle mode and scan for an incoming call while trying to acquire a free repeater approximately every 5 seconds for a 2 minute period.

HARDWARE AND HARDWARE OPTIONS

(Sheet 4 of the MDR 800MHz Duplex Mobile Interconnect Diagram illustrates the possible options and their placement in the system).

HANDSET

The handset contains a microcontroller which interfaces the keypad and Liquid Crystal Display (LCD) to two serial data lines. The serial data lines allow communication with the radio microcontroller on the logic board through a 300 baud link using TTL signals. All messages are inverted 8 bit ASCII.

When the handset display is updated, the logic board passes data over the serial link. When a button, including the PTT switch (except the power button) is pressed, the code for the selected key is sent to the logic board. When no data is transmitted, the two wire link remains at a high logic level. The power button directly controls the toggle flip-flop on the system board which passes power to the entire radio (including the handset power).

HANDSET CABLING OPTIONS

An uncoiled Handset extension cable, which is 18 ft long, Option CC1H (19B801636P1) can be used to replace, or augment the standard 3 ft (7.5 ft stretched) handset cable, Option CC3S (19D901619P4). In line connector, Option CN1A (19A705839P1), is used to mate the cables. Handset cable, 6.5 ft (11 ft. stretched) Option CC1G (19D901619P3), is also available.

OPTION CABLE

Option Cable Option CC3N (19C851585P3) is used to bring all option connections from the System Board through the back of the radio to the outside. This cable is required with all external options: Speaker, Horn Alert and External Tone options with the exception of the Antenna and Power Filter and Cable Extensions.

NOISE SUPPRESSION KIT OPTION

Noise Suppression Kit Option PD1A (19A148539G1) is available for installations where excessive alternator or electrical noises, present on the power cable, do not permit the radio to operate properly. Refer to the interconnect diagram for the radio and options.

POWER CABLE OPTION

18-foot power cable Option CC3R (19B801358P4) is available for installations requiring more than the standard 9-foot cable Option CC7F (19B801358P2).

EXTERNAL SPEAKER OPTION

The external speaker option LS1F (19A149590P1) provides the user with a five-inch waterproof speaker in a LEXAN housing. The radio's 3-watt amplifier drives the speaker's 4-ohm impedance. The speaker leads are connected to pins 2 and 9 of option cable, Option CC3N, using external speaker cable, Option CC9M (19A149590P1)-18 inches or Option CD1W (19A149590P10) 16-foot speaker cable. (Note: When using Option CD1W, CC9M is required also.)

EXTERNAL ALARM

External Alarm Horn Relay Options SU1C (19A705499P1) The relay option connects to pin 13 of cable Option CC3J. The relay can sound the vehicle horn when a call is received. The handset can disable or enable the horn relay option.

SYSTEM DESCRIPTION

The **GE-MARC VE** trunked mobile radio system permits improved access to available RF channels, freedom from annoyance by other users' conversations and a degree of privacy for the user. The trunked mobile radio system consists of a repeater for each channel and the users' mobile radio units. The system uses tone signalling with each mobile being assigned two and/or four tone group tone sequences. Groups of mobiles are assigned the same tones, so that any unit can talk to all other

units in the same group. A Block Diagram is shown in Figure 1.

When originating a call, the mobile identifies an idle repeater channel and interrogates it with a single burst of "busy" tone, the repeater keys its transmitter and sends a burst of "acquisition" tone back to the mobile unit. When the interrogating mobile detects the acquisition tone, it then transmits its collect and group tones, which the repeater regenerates for all idle mobile units on the system.

The idle mobiles, which continually scan all channels, will stop on the active channel if any of the programmed collect tones are detected and wait for group tone(s).

If the correct tone sequence is detected, the mobiles will alert the operator of an incoming call and open their audio circuits. If the correct sequence is not detected, the idle mobiles will resume scanning the channels. Once the mobile is "locked" on a channel, it will remain there until the repeater times out or the operator terminates the call.

OPERATIONAL MODES

The radio will always be in one of three operational modes: idle, wait, or ready. The three operational modes and the conditions that cause the radio to switch from one mode to another are shown in Figure 2.

The radio enters the idle mode when power is turned on and begins scanning channels for incoming calls. The wait mode is entered when the user places a call. The radio remains in the wait mode until a channel is acquired, or if no channel is available. The ready or conversation mode is indicated by an alert tone and the

mode indicator on the control panel. A tone signalling Timing Diagram is shown in Figure 3.

Sequence Flow Charts for each operational mode are shown in Figures 4, 5, and 6.

IDLE MODE

When the radio is in the Idle Mode, the audio is muted and all channels programmed for call decode are sequentially scanned for an incoming call. An incoming call is identified by detecting one of the collect tones programmed in the area. Upon receipt of a collect tone, the mobile looks for a short interval for the group or individual tones, providing that their collect tones are the same. When no valid tone is found, the mobile will resume scanning the channels for an incoming call.

If a group (or individual decode) tone is detected the mobile then looks for busy tone for a 90 millisecond period. If four tones are properly decoded, the mobile will then look for busy tone for 270 milliseconds.

When no valid tones are found, the mobile will resume scanning for a call with the next channel. When a busy tone is found, the mobile will enter the Ready Mode. If busy tone is not detected, the mobile remains in the Idle Mode and continues scanning channels looking for an incoming call.

Removing the handset from the hanger, pressing the PTT switch or pressing the SEND key on the handset, will cause the radio to enter the Wait Mode.

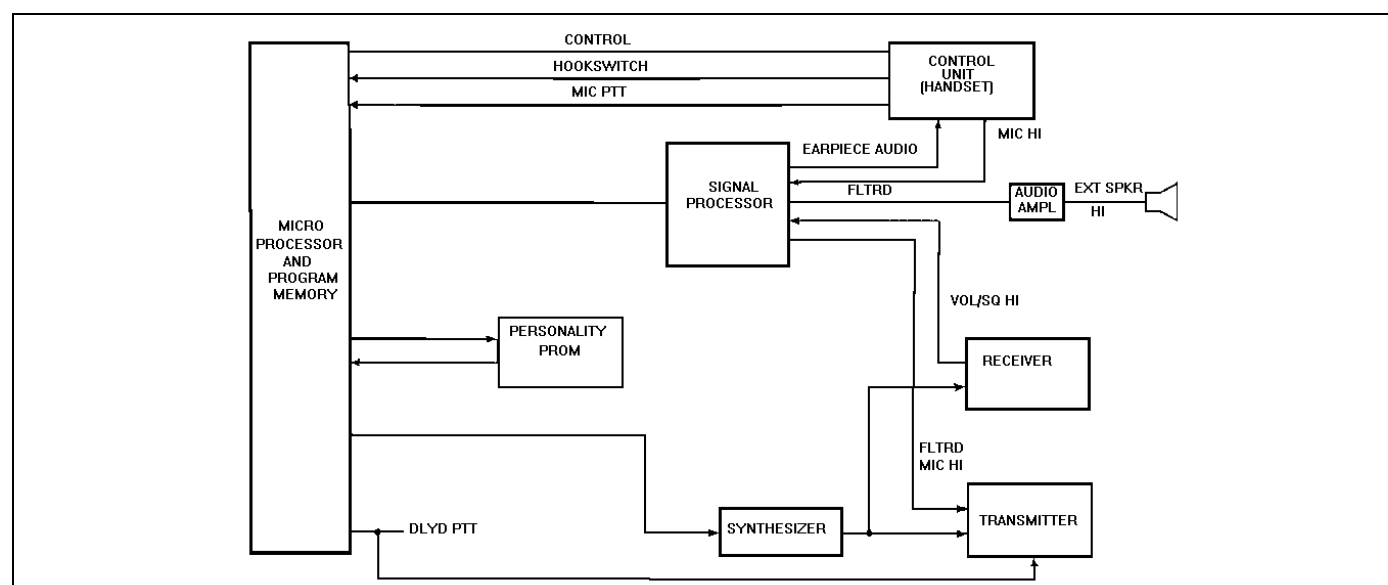

Figure 1 - GE-MARC VE Block Diagram

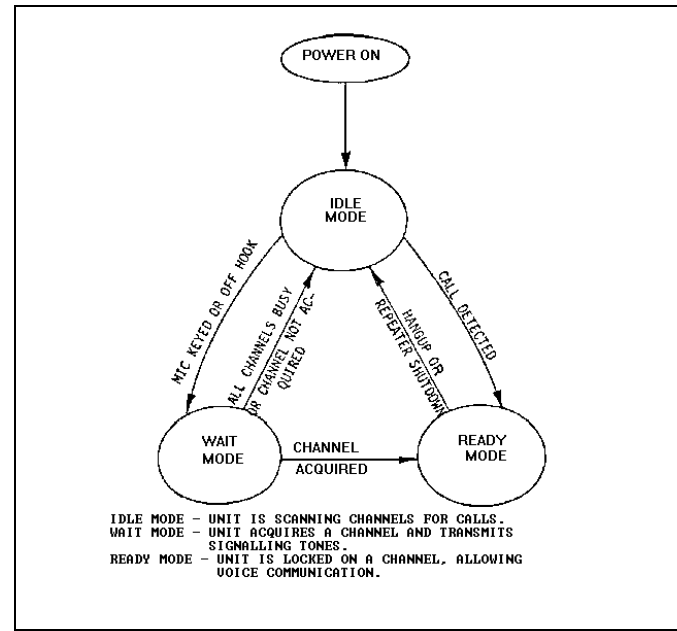

Figure 2 - Operational Modes

WAIT MODE

When the user enters the Wait mode, the display group is checked to make sure it is a valid call-originate group. If it is not valid, a low-frequency tone is heard for one second. If valid, the radio will scan the call-originate frequencies for brief intervals until it finds one with no busy tone on it. If no channel is free, the radio, if programmed for this option, will activate the Call Retry state and display "RETRYING" in the display. Retrying will cause the radio to revert to the Idle mode and scan for an incoming call while trying to acquire a free repeater approximately every 5 seconds for a 2 minute period. If the Retry option is not enabled, the mobile will sound the low-frequency tone, and then return to the Idle mode and display "BUSY".

If a channel with no busy tone is found, the mobile transmits a burst of busy tone to acquire the repeater. The repeater then responds with a burst of acquisition tone. Upon receipt of the acquisition tone, the mobile proceeds to transmit the group tones (either two for four tones). If a four tone sequence is sent, the mobile must detect all four tones and busy tone before entering the Ready mode. If a two tone sequence is sent, the busy tone must be present within 90 milliseconds of the last tone in order for the radio to enter the Ready mode. If no busy tone is present, or if the four tone sequence isn't valid, the mobile will jump to the next channel in the call originate set and check for busy tone as described above.

READY MODE

When an incoming call has been detected, or an idle channel has been acquired, the mobile enters the Ready mode. In this mode, the audio and push-to-talk circuits are enabled, the speaker is unmuted, and the operator is alerted an alert tone. The radio can then be used in the conventional push-to-talk manner with the radio remaining on the channel until the operator hangs up or the repeater drops the busy tone, causing the unit to revert to Idle mode.

NOTE
 If a call is initiated and a sequence of five beeps is sounded, the user cannot access the radio system due to being out of mobile receive range or being inoperative. Any subsequent call will be ignored for 20 seconds.

GLOSSARY OF SYSTEM TERMS

Idle Mode

In the "standby" condition, the mobile is inactive, but prepared to call or be called. The trunked radios are IDLE until they are turned off.

Wait Mode

In the "attempting origination" condition, the Wait mode is entered from Idle mode (only) as the user presses the PTT switch on the handset, or comes "off-hook". If successful, the unit becomes READY. Otherwise, the unit is IDLE Or IDLE/WAIT after all channels are tried.

Ready Mode

In the "operating:" condition, Ready is entered from Idle mode via Wait mode when calling, or directly from Idle when called. Ready mode ends (the radio reverts to Idle) when the user disconnects or with the loss of received Busy Tone from the repeater. This normally occurs when the repeater shuts down after communication is completed.

Busy Tone

A tone of 3051.9 Hz is the standard busy tone. 2918 Hz is the alternate busy tone. The busy tone modulates mobile and repeater transmitters at a low level of 1 kHz deviation continuously. This tone is filtered out of the received audio and is used to hold the communication channel active. It also excludes other mobiles from using the channel when a call is active.

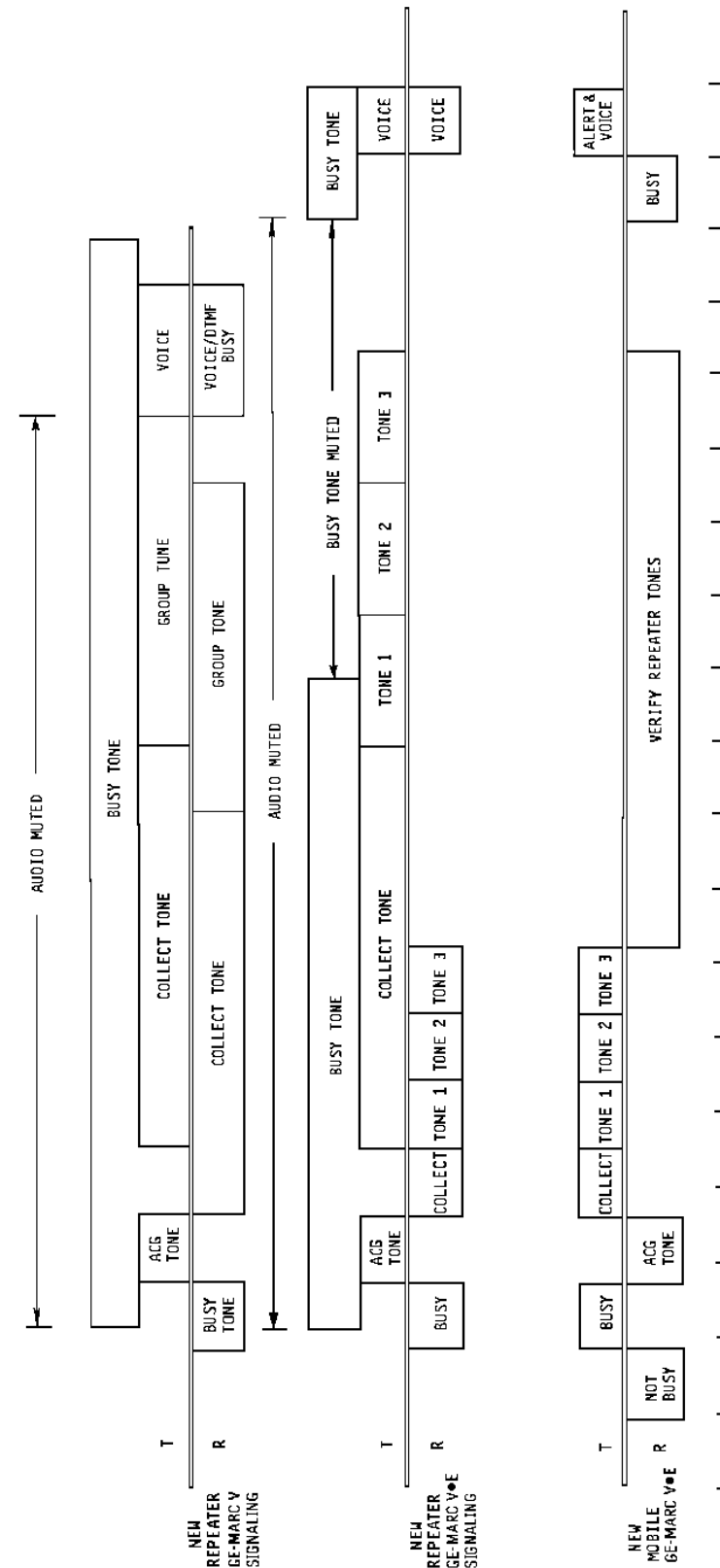

Figure 3 - Signal Timing

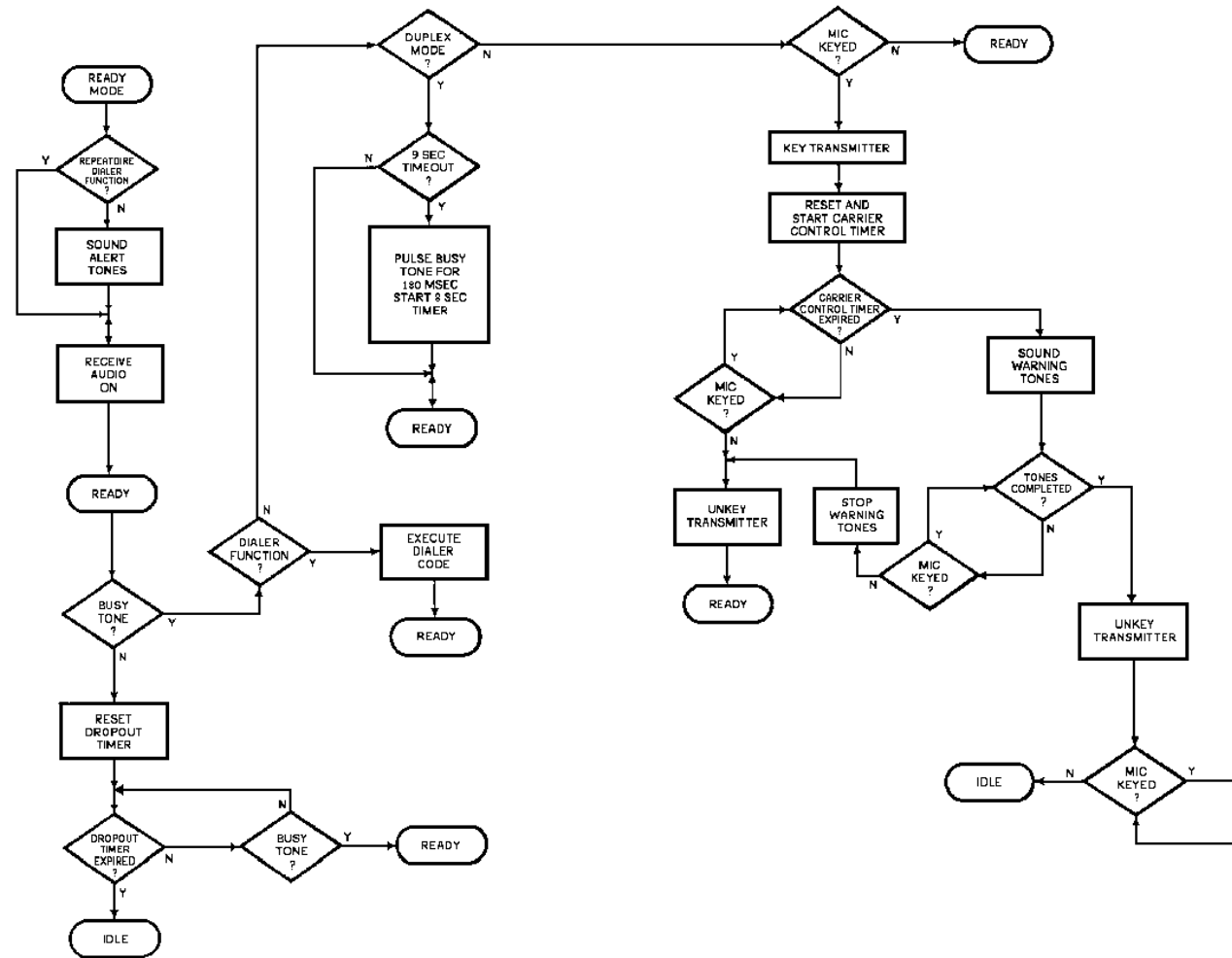

Figure 6 - Ready Mode

Acquisition Tone

A 1962.9 Hz tone sent at full deviation, for 50 milliseconds, from the repeater is used as acknowledgment, from the repeater, that a busy tone was sent and signals the mobile that signalling tones can now be sent.

Collect Tone

A Tone chosen from 34 standardized frequencies, ranging from 508.6 Hz to 2792.4 Hz, is used as the first tone in the group tone sequence. The collect tone is used to gather all mobiles with the same collect tone for decoding a call. The duration of the tone varies as a function of the number of channels which are programmed into the mobile and/or repeater.

In a two tone call, the mobile sends the collected tone for a programmable duration. In the four-tone call, the mobile always sends a 90-millisecond collect tone, which the repeater regenerates, and sends for the correct duration.

Group/Individual Tones

Group/Individual Tones chosen from the 34 standard frequencies, follow the collect tone. In a two-tone call, the second tone is sent for 450 milliseconds. In a four tone call, the second, third, and fourth tones are sent for 90 milliseconds, from the mobile, and 180 milliseconds from the repeater.

RADIO OPERATION

Refer to Operator's Manual LBI-38694 provided with each radio for complete operating instructions.

VISUAL INDICATORS

An alphanumeric Liquid Crystal Display (LCD) Displays telephone numbers and messages associated with call processing and feature processing. The display has eight alphanumeric characters and other dedicated status indicators.

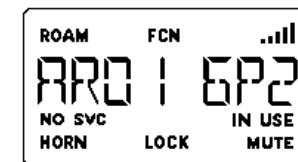

ALPHANUMERIC STATUS INDICATORS

Busy

When "BUSY" is displayed, an attempt to place a call has been attempted but the selected GE-MARC system does not have any available channels. If the "Call Retry" option has been enabled during radio initialization by the system operator, the radio will retry at 5 second intervals, up to 15 times unless the END key is pressed or a channel is acquired, or an out-of-range condition occurs.

Retrying

When "RETRYING" is displayed, the radio is attempting to establish a channel.

Wait

"WAIT" is displayed when the radio is acquiring a channel after call origination has begun.

STATUS INDICATORS

No Service

The NO SVC status indicator is displayed when an attempted call cannot be completed because the unit is out of the service area of the selected GE-MARC system.

Roam

The ROAM status indicator is displayed when the mobile is on channel in the conversation mode.

Function

The FCN status indicator is displayed when the function key has been pressed so that extended features can be accessed.

In Use

The IN USE status indicator is displayed when the radio is transmitting in either simplex or duplex modes of operation.

Bar Status Indicator (|||||)

In conventional or direct mode all 5 bars are lit to indicate the presence of a carrier (on channel RF signal). In trunked mode the bars are used separately as a call counter. Each bar informs the user that an unanswered call has been received (up to 5 total). The display indicates the last received unanswered caller's area/group name.

Horn

The **HORN** status indicator indicates the horn alert is active. **Mute**

The **MUTE** status indicator is displayed when the transmit audio mute feature is active (duplex mode only).

Lock

The **LOCK** indicator is displayed when the lock function has been activated. If the unit is locked before it is turned off, then **--LOCK--** will be displayed when the unit is powered up again.

AUDIBLE INDICATORS**SELF CHECK TEST ALERT**

Three beeps are sounded after the radio is turned on to indicate that the radio has passed the self diagnostic test. The display will show **PASSED** for one second.

CALL RECEIVED ALERT (Trunked mode only)

A short, high frequency tone is sounded when you receive a group call. A two tone alert is sounded when receiving an individual call. **NOTE:** the radio can be preprogrammed to mute the call received alert tones.

CALL ORIGINATE ALERT (Trunked mode only)

"**WAIT**" will momentarily be displayed when a call is being placed. Then a three tone alert is sounded to indicate the call origination is complete. This indicates a channel was acquired and is ready for normal conversation.

SYSTEM BUSY (Trunked mode only)

A low frequency tone is sounded for one second after attempting to place a trunked call and 'BUSY' will be display. This indicates that the GE-MARC system is busy and you should try again later. If the "Call Retry" option has been enabled during radio initialization by the system operator, the radio will retry at 5 second intervals, up to 15 times unless the **END** key is pressed or a channel is acquired, or an out-of-range condition occurs.

OUT OF RANGE ALERT (Trunked mode only)

If the **NO SVC** status indicator is displayed and five beeps are sounded after attempting to place a trunked call, then the radio is out of range of the GE-MARC system. If the beeps sound when the radio is within known range of the system, the radio may need servicing (even though the self diagnostic test passed at power on).

INVALID CALL ORIGINATE ALERT (Trunked mode only)

A low frequency tone is sounded for one second immediately after pressing the handset PTT and the display does not show **WAIT**. This indicates a call was attempted within a group that is not enabled for call originate.

CARRIER CONTROL TIMER (Trunked and Conventional modes)

A pulsed tone signal is sounded after the handset PTT is pressed continuously for a preprogrammed time in trunked mode. After nine seconds of pulsing the alert tone, the radio unkeys the transmitter and communications are interrupted. While the tone is pulsing, the user can release and press the PTT again to reset the timer and resume the conversation. In conventional mode, the radio unkeys and beeps until the PTT switch is released.

In duplex mode a quick two note alert is heard at the interval of the carrier timer to let the user know that the interval has elapsed (i.e. every 1 minute if CCT=1.0 minute) and repeated at every time interval.

GE-MARC SYSTEM TONES

The GE-MARC system may give other tones to alert the user of system time-out, etc. Contact your GE-MARC system operator for details about these alert tones.

KEY DEFINITIONS/FUNCTIONS**MISCELLANEOUS KEYS****Power**

The **POWER** key is located on the backside of the handset. When pressed once the radio performs a self test and will beep three times. The display will momentarily display the frequency set and then display the **AREA** and **GROUP** currently selected. If an error has been encountered **ERROR#** will be displayed. (Contact your authorized service representative if an error message is displayed). Press the power button again to turn the radio off.

Push-To-Talk (PTT)

The PTT button is located on the right side of the handset This key must be held down to transmit during simplex operation.

Volume Up (VOLUP)

The **VOLUP** key is located on the left side of the handset. Press **VOLUP** to increase the volume level.

Volume Down (VOLDN)

The **VOLDN** key is located just under the **VOLUP** key on the side of the handset. Press **VOLDN** to decrease the volume level.

NOTE

When **VOLUP** or **VOLDN** is depressed the volume is momentarily displayed in the Alphanumeric display (ex., **VOL=15**). **VOL 15** is the maximum volume level. After the radio has been turned off the last volume level is retained and is the default volume level after the radio is powered on.

FUNCTION KEYPAD**Send**

The **SEND** key is pressed to initiate a call. When pressed the number in the display is sent. If no number is displayed the last number dialed is sent.

Clear (CLR)

Press **CLR** for less than one second to clear the last digit entered. If **CLR** is held down longer than one second the entire number is cleared.

End

When the **END** key is pressed the active call is terminated.

Recall (RCL)

The **RCL** key is used to recall numbers from memory locations.

Store (STO)

The **STO** key is used to store numbers in memory.

Alphabet Keys (A, B, C)

The **A, B, C** keys are "**Hotkeys**" that provide the MDR with quick dialing for 3 of the most frequently called numbers or emergency numbers.

Function (FCN)

The **FCN** key activates extended features (used with associated secondary keys).

NUMERIC KEYPAD**0-9**

The **0-9** keys are used to enter telephone numbers and activate extended features.

Asterisk (*)

The (*) key is used to ramp through and select areas. This function is only active while calls are not in progress. During a call the (*) key is used to send the **Dual Tone Multi Frequency (DTMF)** tone (*). In dispatch mode (*) brings up the dial tone.

Pound (#)

The (#) key is used to ramp through and select groups and channels. This function is only active while calls are not in progress. During a call the (#) key is used to send the **DTMF** tone for (#). In the telephone interconnect mode (#) ends the call.

TELEPHONE EXTENDED FEATURES

Extended features are accessed by first pressing the **FCN** key then one of the following keys.

KEY	Function	Comments
1 (QZ)	HORN	Enables/Disables the horn alert feature.
2 (ABC)	BACKLIGHT	Enables/Disables the backlight. FCN/2 turns ON. FCN/2 again, turns OFF.
3 (DEF)	OVERDIAL	Enables overdial mode for placing/storing dispatch overdial calls.
4 (GHI)	EXTERNAL SPEAKER	Enables/disables the external speaker in duplex and simplex.
5 (JKL)	SIMPLEX	Disables duplex, allows simplex operation.
6 (MNO)	MUTE	Enables/disables microphone mute during duplex operation.
7 (PRS)	LOCK	Enables the LOCK feature. (Providing a lock code has been pre-programmed).
8 (TUV)	LENGTH	Allows DTMF length to be programmed from keypad (100-450 msec).
9 (WXY)	DELAY	Allows delay after DTMF star (*) to be programmed from keypad (0 - 7 secs).
0 (OPER)	SPC	Selects special call tone set for encoding (if programmed).
*	SYSTEMS	Changes the direction of area ramp. If the area number is known (i.e. 1 - 36) it may be entered in the display, then by pressing star (*) that area will become the new selected area.
#	GROUPS/CHANNELS	Changes the direction of group/channel ramp. If the group/channel number is known (i.e. 1 - 9) it may be entered in the display then by pressing pound (#) that channel/group will become the new selected channel/group.

A	TESTMODE	Allows testmode to be entered (unless disabled from pre-programming).
B	UNUSED	
C	TALK TIME	Displays call timer (active if call is in progress, last call length if call is not in progress).
VOLUP	VOLUME UP	Sets the volume at the max setting. [VOL - 15].
VOLDN	VOLUME DOWN	Sets the volume at the min setting. [VOL - 00].

BASIC OPERATION

The radio is powered on by depressing the green power key located on the bottom of the handset. A self diagnostic test is performed when the radio is first turned on. When testing is complete the Area and Group information is displayed on the handset alphanumeric display. If an error was detected during self test diagnostics the message ERROR# will be displayed. The following table summarizes the possible diagnostic test exceptions.

PC PROG	No personality. The radio has not been PC programmed with the customer information.
ERROR 2	Not Used.
UNLOCK	The synthesizer is unlocked. The synthesizer was tested and failed to lock in the proper amount of time at various frequencies across the band.
PROM Bad	The EPROM program memory checksum test has encountered an error. The EPROM has been corrupted or is malfunctioning.

VOLUME ADJUSTMENT

The user may adjust the volume at any time using the **VOLDN** and **VOLUP** buttons located on the side of the handset. If the volume is adjusted while a call is in progress, no audible beeps will be heard; however, a momentary visual reminder of the volume setting will be displayed. (e.g. [VOL = 07]). If there is no call in progress, a short beep will be heard, in addition to the visual indication. After one second the volume message will be replaced by the selected area and group name. In addition the user selected volume off-hook is saved separately from the user select volume on hook.

AREA SELECTION

The desired AREA can be selected by pressing and releasing the (*) key. This will increment the displayed area to the next AREA available. The user may also depress the FCN key and then the (*) key to reverse the direction of the AREA selection. The area may also be entered directly by entering the desired area number and then pressing the (*) key.

GROUP SELECTION

The desired group can be selected by pressing and releasing the (#) key. The direction of ramping can be changed by pressing the FCN key and then pressing the (#) key. The group may also be entered directly by entering the desired group number and then pressing the (#) key.

CHANNEL ACTIVITY

To provide quick access to the communications channels, the **GE-MARC V/V*E** trunked radio system continually monitors the activity on all the system channels. When a call is initiated, the trunked radio automatically seeks a non busy channel. Once communications have been established, if a channel has not been active for six seconds or more the channel is disconnected; i.e. communications are interrupted. If this occurs before the conversation is complete, the call must be reinitiated.

To avoid confusion it is recommended that a procedure be set up so that the originator of the call is the one designated to re-establish communications.

PLACING A DISPATCH CALL**NOTES**

If you plan on a lengthy call (or several calls), the vehicle engine should be running to maintain battery charge.

As each key is pressed on the keypad, the display should be observed before proceeding to the next key. Pressing keys too rapidly in succession could result in incomplete or incorrect calls.

1. The user must first select the desired **AREA** and **GROUP**.
2. The user can place a dispatch call by pressing the PTT switch located on the side of the handset (or remove the handset from its holder when the pre-programmed option has been enabled).
3. The display will change from the selected area and group to **[WAIT]** while the radio is acquiring a repeater.

4. The radio will sound a three tone alert signal when you can begin the conversation.
5. If the radio is out of the range of the selected system, 4 short and 1 long beep will be heard and the **NO SVC** status indicator will be displayed for approximately 20 seconds. While the **NO SVC** status indicator is displayed, no attempts can be made to place a call. If a new area is selected the **NO SVC** indicator goes out and the call can now be attempted in the new service area. If all available repeaters are busy when the call is attempted, the user will hear 1 long beep and the word **[BUSY]** will appear in the display. If the call retry option was enabled during PC programming, **[RETRYING]** will appear in the display instead of **[BUSY]**.
6. The selected area and group will be displayed again once the call is completed.

PLACING AN INTERCONNECT OR DISPATCH OVERDIAL CALL

There are four different ways to place an interconnect or dispatch overdial call.

1. The user must first press **FCN 3. [OVERDIAL]** will be displayed. The user must then manually dial the dispatch ID (2 or 4 tone sequence for example [-1809] or [18092310]). The sequence will be preceded by the overdial prompt[-]. Then press the **SND** key.
2. The **SND** key can be pressed which will automatically redial the last phone number or dispatch ID.
3. The user can recall previously stored dispatch ID's and phone numbers from memory and then press **SND**.
4. The user can remove the handset from its holder (pre-programmed option). If a dispatch or telephone number was not entered, prior to removing the handset from the holder, the radio will acquire a channel. After the channel has been acquired recall or enter the desired number and press the **SND** key. If entering a dispatch number takes more than 5 seconds depress the PTT switch periodically to keep the channel active while the ID sequence is entered.

ENDING A CALL

The call can be ended three ways:

1. Pressing the **END** key.
2. A system disconnect or time out occurs. During a dispatch call the time out occurs after 6 seconds of channel silence.

During an interconnect call the timeout occurs after 30 seconds of channel silence.

- Returning the handset to the holder (a pre-programmed option).

RECEIVING A CALL

When a call is received by the radio, the radio decodes the call. A single alert tone will sound indicating a GROUP call has been received or a two tone alert will sound if an **INDIVIDUAL** call has been received. The display will show the user the **AREA** and **GROUP**, when a receiving a group call, and the **AREA** and **INDIVIDUAL** decode when an **INDIVIDUAL** call is received.

If a simplex dispatch call is desired, simply pick up the handset and use the PTT switch transmit to transmit to the caller. If the call is an interconnect call, press the star (*) to answer the call and place the unit in duplex.

Duplex operation must be enabled during PC programming for the tone set being used during duplex mode. If Auto-interconnect is enabled for the area and the Individual tone set being decoded, the user may enter duplex by removing the handset from the cradle. If the handset has already been removed from the cradle when the call is received, the user must press the (*) to go into duplex.

DIRECT MODE OPERATION

The Direct Mode provides short range, line of sight communications for radios having the talkaround option installed. In the Direct (or talk around) mode, the radio is not operational on the GE-MARC system.

- Using the (*) key select the direct mode area. The Group key (#) has no effect in the direct mode frequency set.
- Before making a call, determine if the channel is in use. Press **CLR** key to momentarily disable the squelch to monitor the channel. Also, removing the handset from the holder allows you to monitor the channel without disabling the squelch (Busy Tone is disabled). The status indicator (||||) in the display will also show if the channel is in use.
- Press the PTT switch and send your message.

CONVENTIONAL MODE OPERATION

- Using the (*) key select the conventional mode area. If more than one channel is available in the conventional area, press the (#) key to select the channel (up to 9 channels may be available in one conventional area).

- Before making a call, determine if the channel is busy by pressing the **CLR** key momentarily to disable the squelch and monitor the channel for activity. Also removing the handset from the holder allows you to monitor the channel without disabling the squelch (Channel Guard is disabled). The ||||| status indicator in the display will be active if the channel is in use.

- Press the PTT switch and send your message.

Call Timer

The call timer displays the length of the time the conversation in progress, or most recent call, has taken. To display the call timer, during a conversation, press the **FCN** key and then press the **C** Hotkey. The timer will be displayed and will be operational. The call timer may be viewed after a call has been completed by pressing the **FCN** key and then pressing the **C** key. The timer can be removed from the display by pressing the **CLR** key.

Last Digit Clear and Display Clear

To clear the last digit entered in the display, momentarily depress the **CLR** key. To clear the entire display depress the **CLR** key and hold for one second.

Storing Numbers

The number of dial locations available to the user is pre-programmed by the system operator. The user may chose 10, 20, 30, 40 or 50 locations. The maximum number of digits stored in any location is 15. The user can store phone numbers and dispatch IDs by following these steps:

- The user must first key in the telephone number, or dispatch over dial tone sequence, from the keypad.
- The user must then press the **STO** key.
- ADDR xx** will be displayed where xx is the next available storage address.
- If the suggested memory location is OK, then press the **STO** key. This will store the number and return the radio to normal operation.
- If the displayed address is not acceptable, key in the memory location (1-50, depending on the number of locations enabled by pre-programming). The **A, B** or **C HOTKEYS** are also valid memory locations.

NOTE

If a number already exists in the memory location entered then the new number will replace it. If all locations have something programmed in them the prompt **[FULL]** will be displayed.

Recalling Numbers

The user can recall numbers previously stored by following these steps:

- The user must first press the **RCL** key.
- The memory location of the desired number is then keyed in (1-50, depending on the number of locations enabled during PC programming or **HOTKEY A, B** or **C**). The dispatch or phone number will be displayed. If the number is greater than 8 digits long then the first 8 digits will be displayed for one second and then the last eight digits will be displayed and remain in the display. If a location does not have anything in it, **[EMPTY]** will be displayed.

NOTE

There are 3 **HOTKEYS (A, B and C)** available for storing your most frequently called numbers. When used to initiate a call these locations are recalled and dialed simply by pressing the **HOTKEY.RCL** is not required.

NOTE

When specifying repertoire locations, using either **RCL** or **STO**, the user need not enter the 0 preceding locations 1 through 9 (i.e. **RCL 3**). However; if the entire number is specified, the action will be taken immediately. If the user presses just the last digit then the action will not be taken for one second. This allows the user time to enter the second digit (i.e. **RCL 3 2**).

Hotkeys

Pressing **A, B** or **C** will automatically recall and dial the number stored at that location without further user intervention.

Last Number Redial

The user can press the **SEND** key with an empty display and the radio will dial the last dialed number. By pressing the **RCL** key twice, the user can display the last number dialed. After displaying the number, the user can redial by pressing the **SEND** key.

Locking the MDR Mobile Radio

The user may choose to lock the radio by pressing the **FCN** key and then the 7 (**PRS**) key. The lock status indicator will be displayed. If the unit is turned off and then on again while it is locked, **[- - LOCK - -]** will be displayed. In this mode no calls can be originated or received. This feature is disabled if a lock code is not entered during initial programming by the system operator. PC programming. Lock codes can be 1 to 7 digits long. The lock feature is operational only when a call is not in progress.

Unlocking the Mobile

After the mobile has been locked the user may unlock the mobile by keying in the lock code. If an incorrect digit is entered simply start over with the correct code.

Backlight

The backlight function can be toggled **ON** or **OFF** by pressing the **FCN** key and then the 2 (**ABC**) key.

Horn

If your radio has the horn alert option; it can be enabled and disabled by pressing the **FCN** key and then pressing the 1 (**QZ**) key.

External Speaker

To enable the external speaker, press the **FCN** key and then the 4 (**GHD**) key. Toggling this function provides the user with the capability to have private conversations or allow other passengers in the vehicle to hear the conversation. After power on the external speaker is enabled while in conventional mode and disabled during trunked mode.

Call Hold (Mute)

The user can Enable or Disable the microphone, so that the called party cannot hear your conversation, by pressing the **FCN** key and then the 6 (**MNO**) key. This feature is only available in duplex operation.

Simplex Operation

The user can choose to terminate duplex operation and still maintain the interconnect call in progress by pressing the **FCN** key then pressing the 5 (**JKL**) key. This returns the radio to the simplex mode of operation. To return to duplex, the user can press the star (*) key.

DTMF Digit Length

The user can change the duration of the DTMF tones by pressing the **FCN** key then the **8 (TUV)** key. The prompt **[LENGTH?]** is displayed and the radio waits for the user to enter a value between 2 and 9. If an out of range value is entered the radio will display the correct range i.e. **[RNG= 2-9]**. The user can then enter the desired value. The numbers entered represent 50 millisecond intervals (i.e. 100 - 450 msec).

Delay After DTMF Star (*)

The user can also change the duration of the DTMF star (*) tone. This value can be changed by pressing the **FCN** key and then the **9 (WXY)** key. The prompt **[DELAY?]** is returned and the radio waits for the user to enter the desired value between 0 and 7 milliseconds. If an out of range value is entered the radio will display the correct range i.e. **[RNG= 0-7]**. The user can then enter the desired value.

TABLE 1 - CHANNEL GUARD TONE FREQUENCIES

Standard Tone Frequencies Hz			
67.0	97.4	136.5	192.8
71.9	100.0	141.3	203.5
74.4	103.5	146.2	210.7
77.0	107.2	151.4	
79.7	110.9	156.7	
82.5	114.8	162.2	
85.4	118.8	167.9	
88.5	123.0	173.8	
91.5	127.3	179.9	
94.8	131.8	186.2	

TABLE 2 - DIGITAL CHANNEL GUARD CODES

PRIM. CODE	EQUIV. CODE	PRIM. CODE	EQUIV. CODE	PRIM. CODE	EQUIV. CODE
023	340,766	142	174,270	266	655
025		143	333	271	427,510,762
026	566	144	466,666	274	652
031	374,643	145	525	276	326,432
032		147	303,306,761	307	362,565
036	137	150	256,703	311	330,456,561
037	560,627				
043	355	152	366,415	312	515,663,743
047	375,707	153	606,630	315	321,673
051	520,771	155	233,660	317	546,614,751
053		156	517,741	324	343,570
054	405,675	157	322,503	325	550,626
056	465,656	161	345,532	331	372,507
057	172				
060	116,737	162	416,553	332	433,552
065	301	163	460,607,654	344	471,664,715
066	734	164	207,732	346	616,635,724
067	516,720	165	354	351	353,435
071	603,717,746	171	265,426	356	521
072	470,701			363	436,443,444,662
073	640	212	253	446	467,511,672
074	360,721	213	263,736	447	473,474,731,744
075	501,624	217	371,453,530	452	524,765
076	203,754	222	445,457,575	454	513,545,564
104	226,557	223	350,475,750	455	533,551
107	365	224	313,506,574	462	472,623,725
114	327,615	225	536	523	647,726
115	534,674	227	261,567	526	562,645
117	411,756	231	504,631,636,745		
122	535	234	423,563,621,713		
123	632,657	235	611,671,723		
125	173	236	251,704,742		
127	412,441,711	237	464,642,772		
130	364,641	243	267,342		
131	572,702	245	370,554		
132	605,634,714	246	542,653		
133	413,620	252	661		
134	273	254	314,612,706		
135	205,610	255	425		
136	502,712	262	316,431,730		

NOTE

To reverse the polarity of the digital Channel Guard codes, in the PC programmer, type I (i) ("inverted") before the code number, i.e. I023.

**MDR MOBILE RADIO ASSEMBLY
ISSUE 1
REAR ASSEMBLY
19D901916G22**

SYMBOL	PART NO.	DESCRIPTION
----- ASSEMBLIES -----		
A1	19D902172G1	LOGIC BOARD
A2	19D902123G18	RF BOARD
A3	19D902188G2	AUDIO BOARD
A4	19D903504G1	DUPLEX INTERFACE BOARD
A5	19D901891G1	SYSTEM BOARD
----- PLUGS -----		
P105	19A702104P2	Connector: Shorting Jumper, Gold Plated. (Housing Color: White).
P702	19B801359P5	Connector, 12 positions.
----- INTEGRATED CIRCUITS -----		
U101	19A143904P2	RF Amplifier: sim to MHW820-1.
U703	344A3796G2	PROM kit.
U704	19A705553P1	Digital, CMOS: EEPROM, sim to X1COR X24C16.
----- CABLES -----		
W1	19A705301P5	RF Cable assembly.
W6	19B801467P1	Cable Assembly, electrical.
W21	19B801467P2	Cable assembly, electrical.
W22	19B801454P31	Cable.
W23	19B801454P32	Cable.
W24	19B801454P34	Cable.
W25 and W26		Part of Talk-Around Kit
----- FILTER -----		
Z903	19A705126P1	Ceramic, High Dielectric: 1000pF, 50 V.
----- MISCELLANEOUS -----		
3	19C851442P1	Cover.
5	19A700033P3	Lockwasher, external tooth: M2.5.
6	19A702381P520	Screw, thd. form: TORZ Drive, No. M3-0.6 x 20.
7	19A702381P508	Screw, thd. form: No. 3.5-0.6 x 8.
8	19A115204P1	Grease.
9	19A700033P6	Lockwasher, external tooth, M3.5.
10	19A701312P5	Flatwasher: M3.5.
11	19C851585P2	Cable.
12	19J706152P5	Retainer strap: sim to Panduit Corp. SST-1.
13	19A705282P1	Clip.
16	19A705220P1	Spring tension clip.
19	19A705417P1	Ground contact.
22	19A705421P2	Foam pad.
31	19A704944P1	Spring tension clip.
43	344A3235P1	Heat sink clip.
50	344A3324P1	Ground clip.
51	19C851699G1	Power module support.
62	19D901881G5	Casting.
64	19B234763P17	Pad.
70	19C337683G1	Duplexer mounting support.
71	19A702364P320	Machine screw.
72	19A702364P308	Machine screw, TORZ Drive: No. M3-0.5 x 8.
73	19B801362P3	Duplexer.

*COMPONENTS ADDED, DELETED OR CHANGED BY PRODUCTION CHANGES

SYMBOL	PART NO.	DESCRIPTION
TOP COVER ASSEMBLY 19A705216G1		
----- MISCELLANEOUS -----		
2	19D901894P1	Top cover.
3	19B801384P4	Shield.
BOTTOM COVER ASSEMBLY 19C851573G1		
----- MISCELLANEOUS -----		
2	19C851573P2	Bottom cover.
FRONT CAP ASSEMBLY 19D903555G1		
HANDSET 344A3783P1		
SYSTEM CONNECTION CABLE 19A705235P1		
HARDWARE KIT 19A705109G3		
----- MISCELLANEOUS -----		
1	19A705406P408	Machine bolt, hexagon: M4-0.7.
2	19A702362P908	Machine screw.
3	19A702364P408	Machine screw: TORX Drive, M3.5 - 0.6 x 8.
11	19A701863P16	Loop dip.

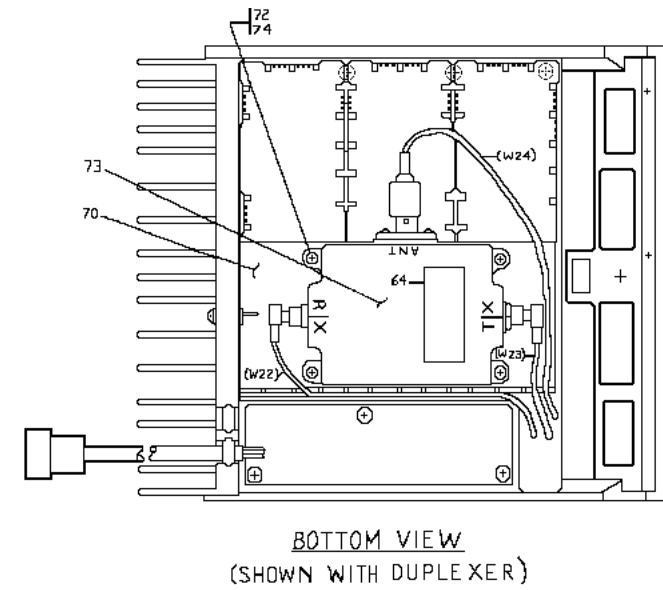
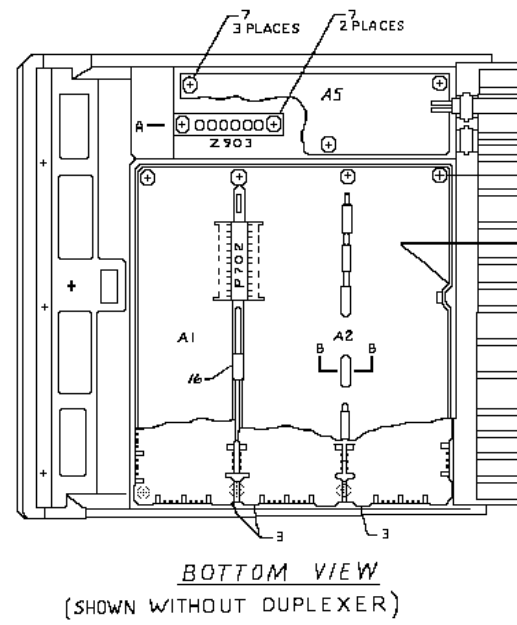
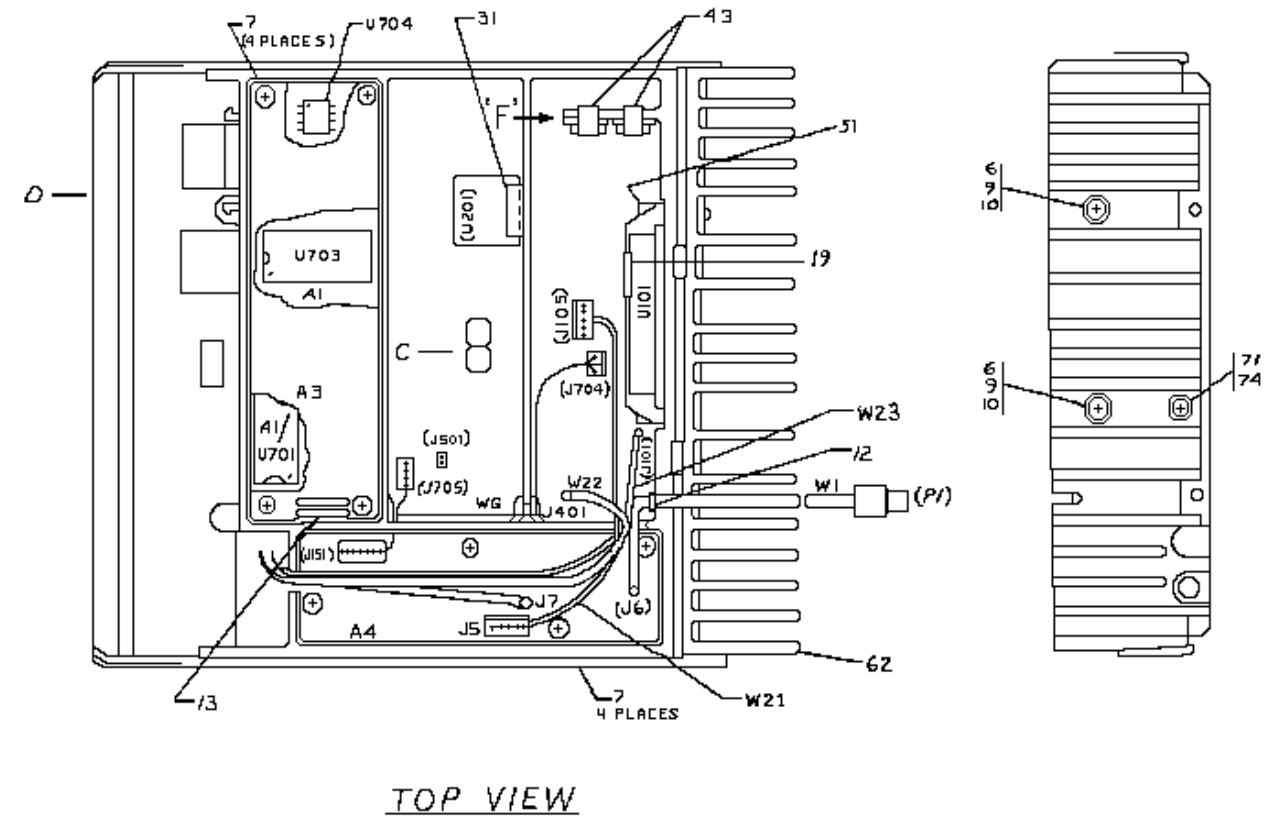
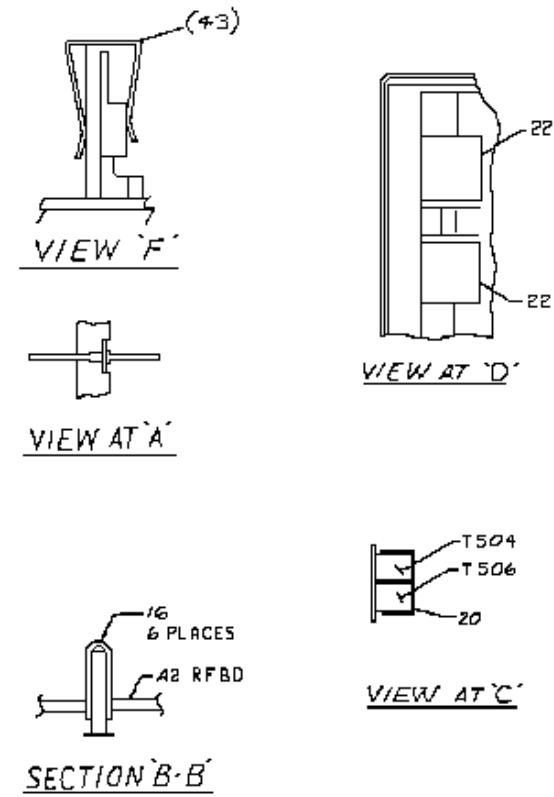

RADIO ASSEMBLY DIAGRAM
19D901916G22

(19D901916, Sh. 4, Rev. 0)

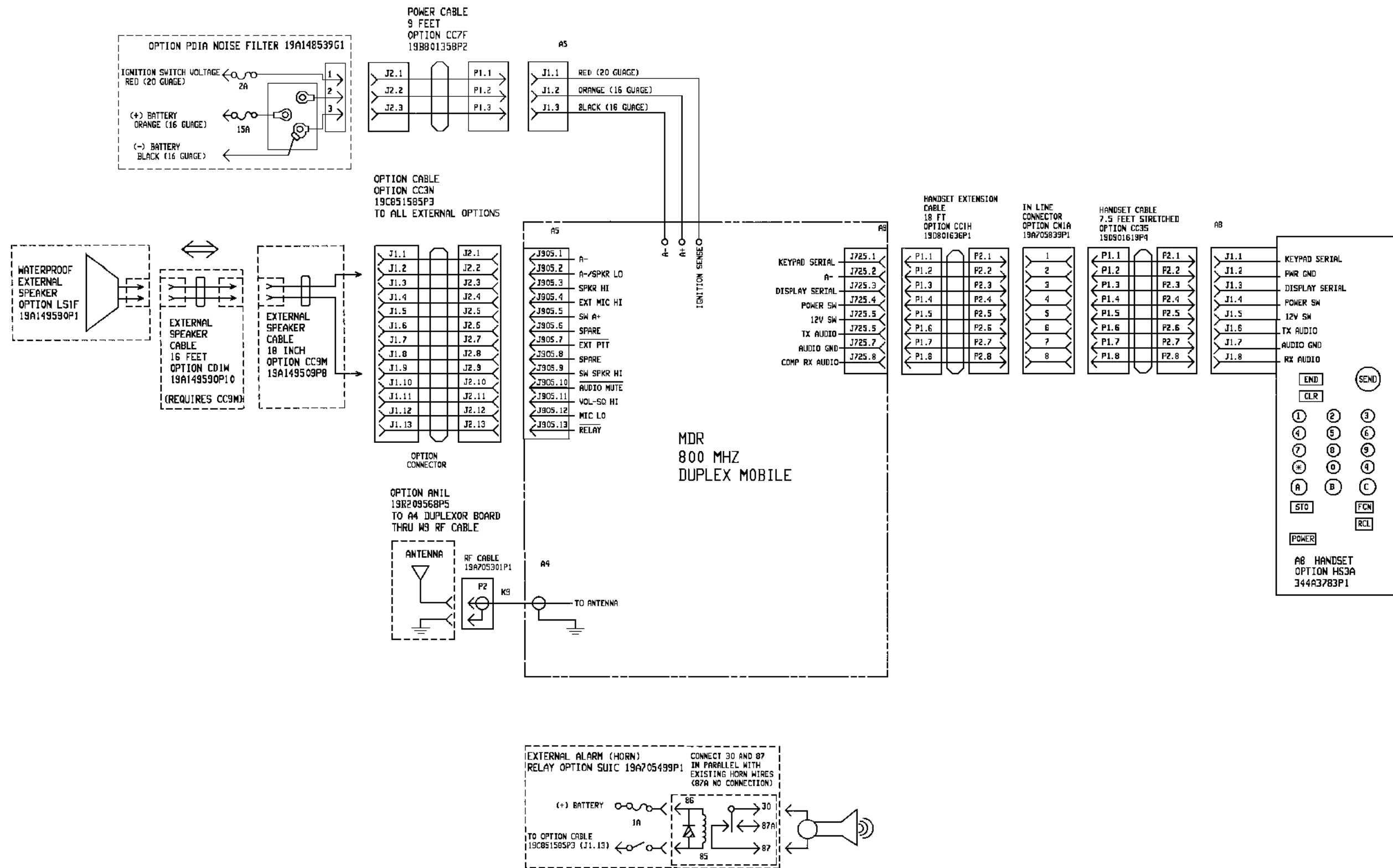

800 MHz Duplex Mobile (System)

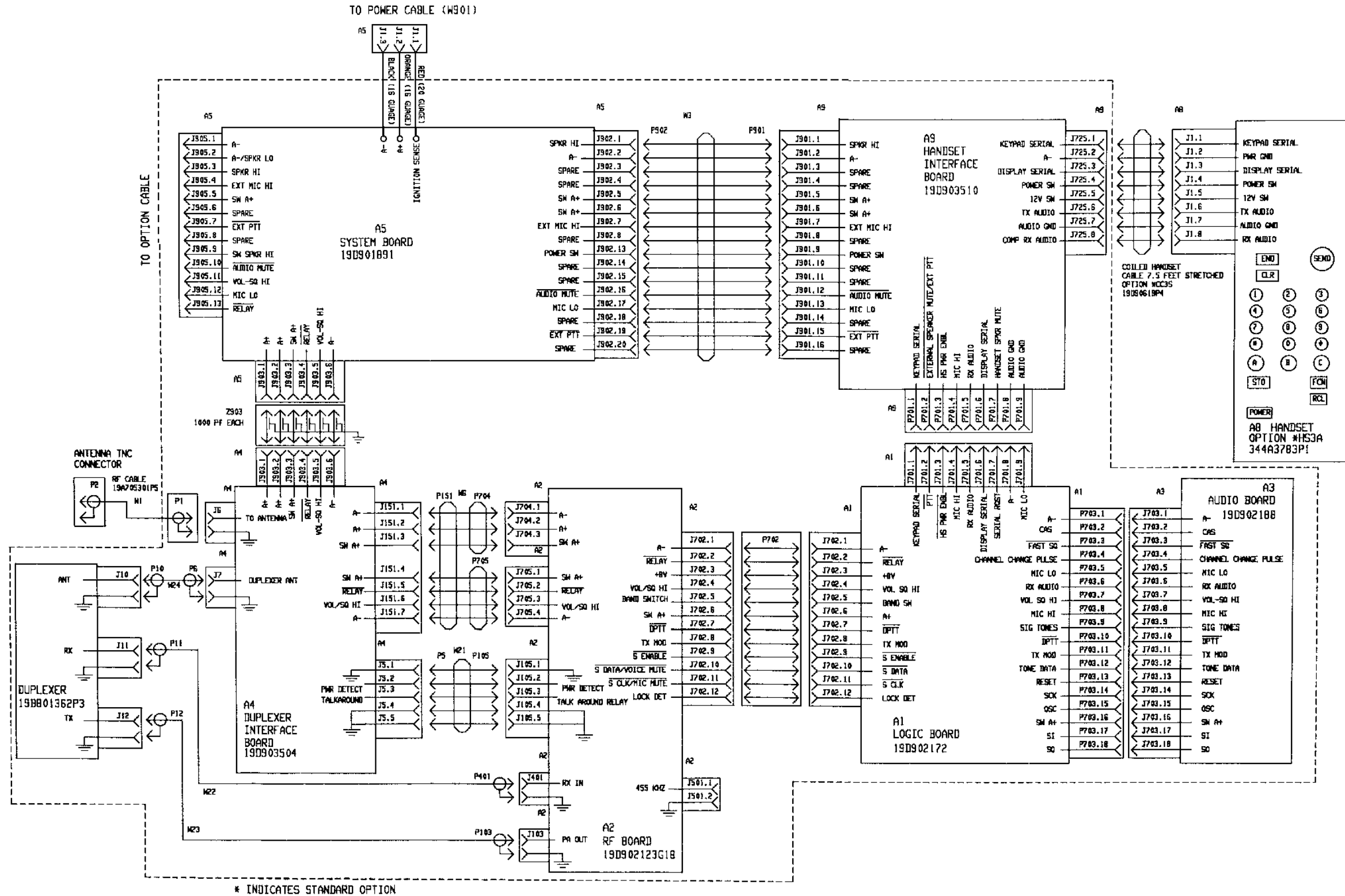

Standard 800 MHz Duplex Mobile

(19D903561, Sh. 2, Rev. 4)

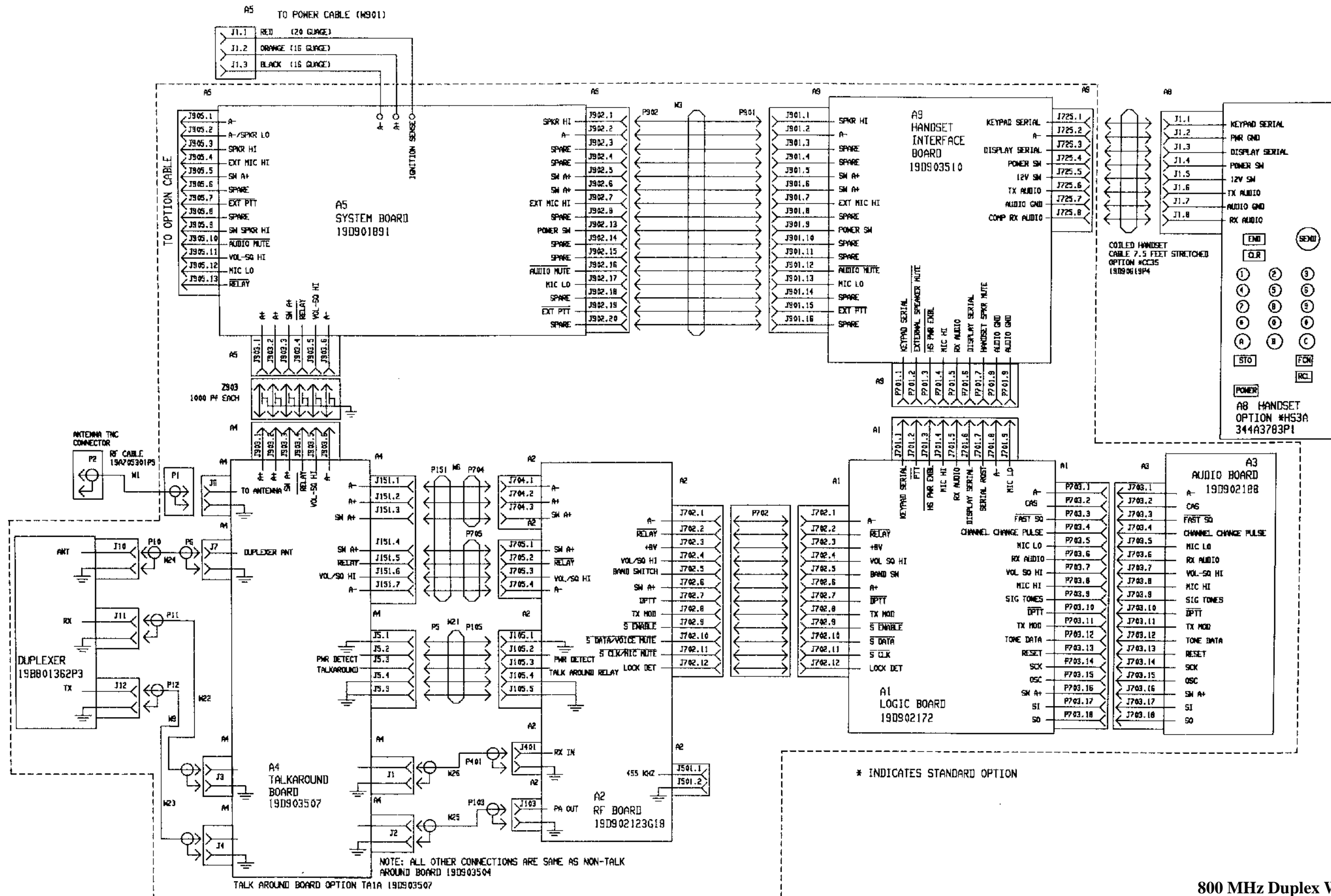

800 MHz Duplex With Talk-Around

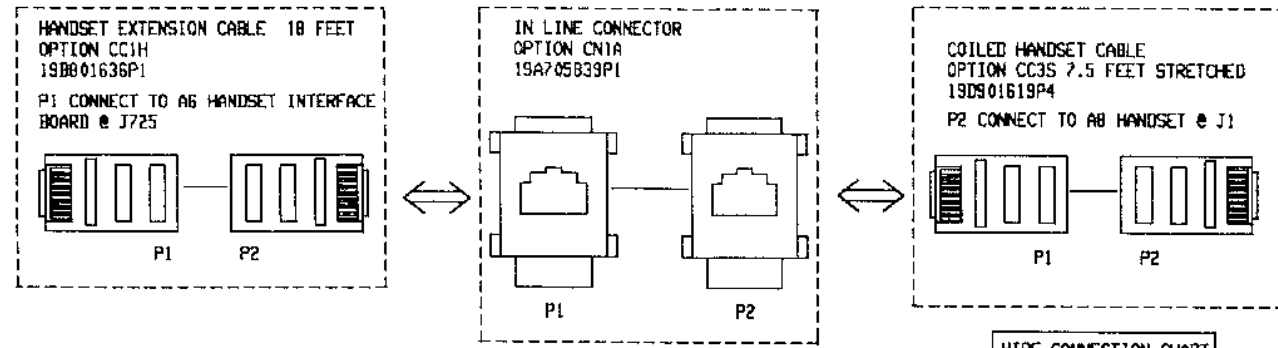

WIRE CONNECTION CHART

FROM	COLOR	TO
P1-1	BLACK	P2-1
P1-2	RED	P2-2
P1-3	ORANGE	P2-3
P1-4	YELLOW	P2-4
P1-5	GREEN	P2-5
P1-6	BLUE	P2-6
P1-7	BROWN	P2-7
P1-8	GREY	P2-8

OPTION NUMBER	OPTIONS AVAILABLE	EGE NUMBER
AN1L	ANTENNA, 800 MHz, ROOFTOP, BNC	19B209568P5
* CC2F	POWER CABLE, 9 FEET	19B801258P2
CC2R	POWER CABLE, 18 FEET	19B801258P4
* H53A	HANDSET	344A3783P1
CC1G	COILED HANDSET CABLE, 11 FEET STRETCHED	19D901619P3
* CC3S	COILED HANDSET CABLE, 7.5 FEET STRETCHED	19D901619P4
CN1A	IN LINE CONNECTOR	19A705839P1
CC1H	HANDSET EXTENSION CABLE 18 FEET	19B801636P1
TQ0618	TEST BOX	---
LS1F	WATER-PROOF SPEAKER 5" X 5"	19A149590P1
CC3M	EXTERNAL SPEAKER CABLE, 18 INCHES	19A149590P8
CD1M	EXTERNAL SPEAKER CABLE, 16 FEET (REQUIRES CC3M)	19A149590P10
CC3N	OPTION CABLE	19C851585P3
TA1A	TALKAROUND KIT	344A3803G1
PD1A	NOISE SUPPRESSION KIT	19A148539G1
SU1C	HORN ALARM RELAY KIT	19A705499P1
TQ3361	PC PROGRAMMER CABLE	19B801417P2
TQ3310	PC PROGRAMMING INTERFACE BOX	19D438367G1
TQ3355	PC PROGRAMMING SOFTWARE	344A3246G1
MD8712	PC PROGRAMMING SOFTWARE DOCUMENTATION	344A3250P1
* LX18	SHELL HANDSET HOLDER	19A705606P2
* HA1H	MOUNTING BRACKET KIT	19A138851G11

* OPTIONS ARE STANDARD

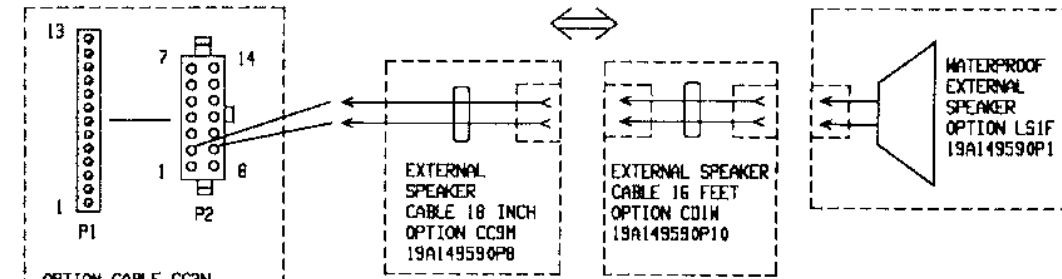
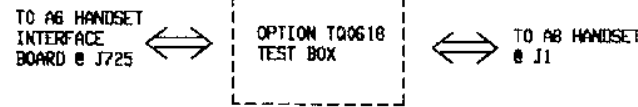

WIRE CONNECTION CHART

FROM	COLOR	TO
P1-1	BLACK	P2-1
P2-1	BLACK	P2-2
P1-3	WHITE	P2-3
P1-4	RED	P2-4
P1-5	GREEN	P2-5
P1-6	PINK	P2-6
P1-7	BLUE	P2-7
P1-8	YELLOW	P2-8
P1-9	ORANGE	P2-9
P1-10	GRAY	P2-10
P1-11	VIOLET	P2-11
P1-12	BROWN	P2-12
P1-13	TAN	P2-13

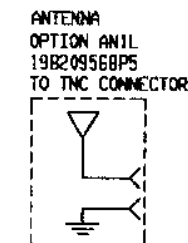
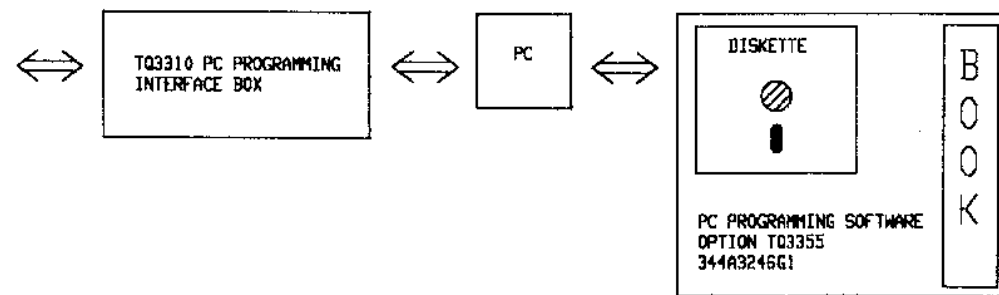
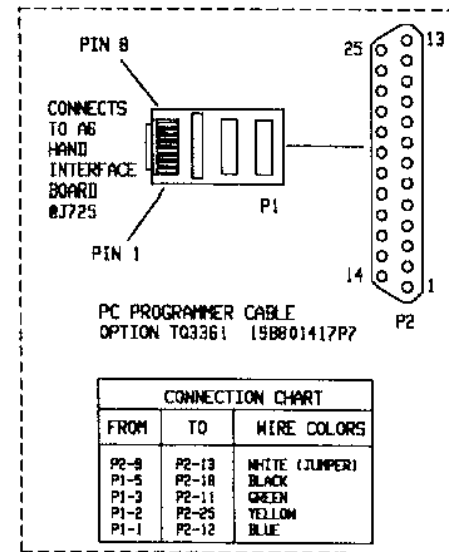
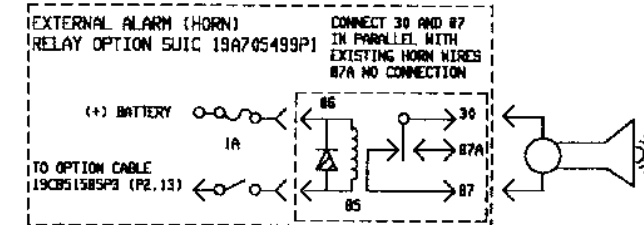
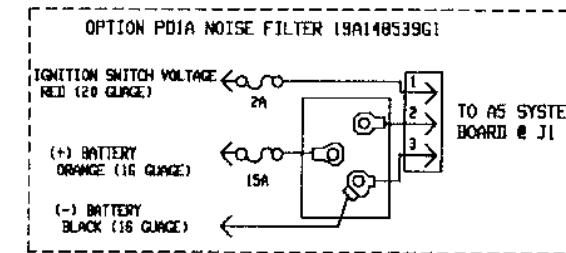

800 MHz Duplex Mobile (Options)

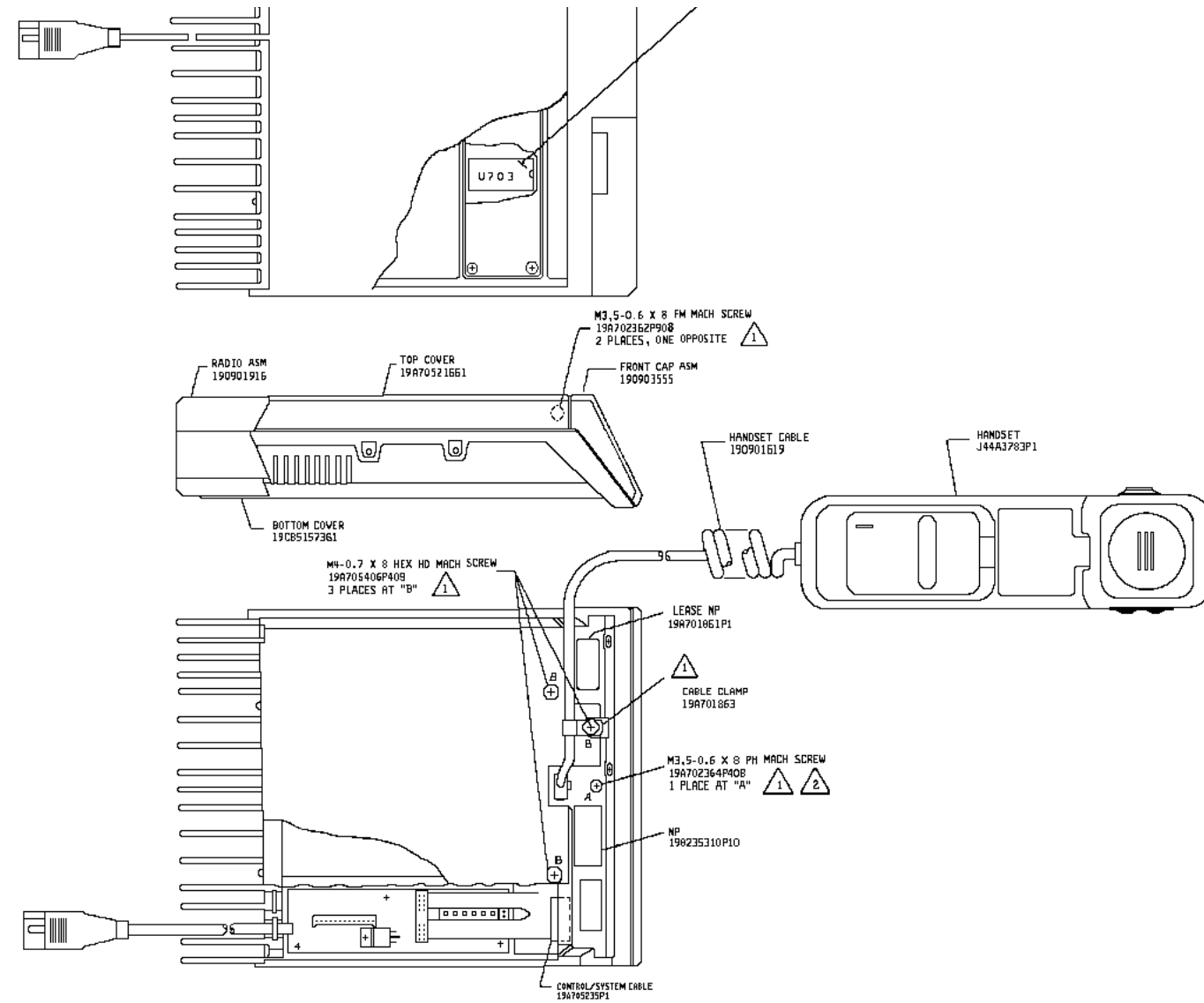

NOTES:

- 1 PART OF HDW KIT PL19A70510963.
- 2 2 OF THESE SCREWS ARE ALSO SUPPLIED AS PART OF HDW KIT PL19A138051G11 FOR FIELD ASM OF CONTROL PANEL.