

Maintenance Manual

Universal Desk Charger

Rapid - 344A3072P1

Standard - 344A3072P2

CAUTION

THESE SERVICING INSTRUCTIONS ARE FOR USE BY QUALIFIED PERSONNEL ONLY. TO AVOID ELECTRIC SHOCK DO NOT PERFORM ANY SERVICING OTHER THAN THAT CONTAINED IN THE OPERATING INSTRUCTIONS UNLESS YOU ARE QUALIFIED TO DO SO. REFER ALL SERVICING TO QUALIFIED SERVICE PERSONNEL.

WARNING: TO PREVENT FIRE OR ELECTRIC SHOCK HAZARD, DO NOT EXPOSE THIS PRODUCT TO RAIN OR MOISTURE.

CAUTION: TO PREVENT ELECTRIC SHOCK DO NOT USE THIS (POLARIZED) PLUG WITH AN EXTENSION CORD, RECEPTACLE OR OTHER OUTLET UNLESS THE BLADES CAN BE FULLY INSERTED TO PREVENT BLADE EXPOSURE



 <p>The lightning flash and arrowhead within the triangle is a warning sign alerting you of "dangerous voltage" inside the product.</p>	<p>CAUTION</p> <p>RISK OF ELECTRIC SHOCK DO NOT OPEN</p> <p>CAUTION: TO REDUCE THE RISK OF ELECTRIC SHOCK. DO NOT REMOVE COVER (OR BACK). NO USER-SERVICABLE PARTS INSIDE. REFER SERVICING TO QUALIFIED SERVICE PERSONNEL.</p>	 <p>The exclamation point within the triangle is a warning sign alerting you of important instructions accompanying the product.</p>
<p align="center">See Marking On Bottom/Back Of Product</p>		

TABLE OF CONTENTS

SPECIFICATIONS	3
IMPORTANT SAFETY INFORMATION	3
DESCRIPTION.....	5
ACCESSORIES AND REPLACEMENT PARTS	6
INSTALLATION	7
INDICATORS	8
OPERATION.....	9
MAINTENANCE INSTRUCTIONS	9
Removal and Replacement Instructions	9
Troubleshooting Procedures	12
SCHEMATIC DIAGRAMS	15
PARTS LISTS	18
ILLUSTRATED PARTS BREAKDOWN	19

NOTICE!

This manual covers Ericsson and General Electric products manufactured and sold by Ericsson Inc.

NOTICE!

Repairs to this equipment should be made only by an authorized service technician or facility designated by the supplier. Any repairs, alterations or substitution of recommended parts made by the user to this equipment not approved by the manufacturer could void the user’s authority to operate the equipment in addition to the manufacturer’s warranty.

NOTICE!

The software contained in this device is copyrighted by Ericsson Inc. Unpublished rights are reserved under the copyright laws of the United States.

This manual is published by **Ericsson Inc.**, without any warranty. Improvements and changes to this manual necessitated by typographical errors, inaccuracies of current information, or improvements to programs and/or equipment, may be made by **Ericsson Inc.**, at any time and without notice. Such changes will be incorporated into new editions of this manual. No part of this manual may be reproduced or transmitted in any form or by any means, electronic or mechanical, including photocopying and recording, for any purpose, without the express written permission of **Ericsson Inc.**

SPECIFICATIONS

VOLTAGE SOURCE	120/230 Vac \pm 10%, 50/60 Hz
POWER CONSUMPTION	
Rapid Charger	33 watts
Standard Charger	6 watts
FUSE RATING	
Rapid Charger	1 Amp 250 volt, slow blow
Standard Charger	1Not fused
RECHARGE TIME	
Rapid Charger	1 hour
Standard Charger	14 hours
OPERATING TEMPERATURE RANGE	+5° to +45°C
DIMENSIONS (HxWxD)	
Height	4.4 inches (112 mm)
Width	4.7 inches (118.5 mm) (front) 5.3 inches (134.5 mm)(rear)
Depth	6.6 inches (168 mm)
WEIGHT	
Rapid Charger	2.0 lb. (0.91 kg)
Standard Charger	1.4 lb. (0.64 kg)

IMPORTANT SAFETY INFORMATION

1. **SAVE THIS MANUAL** - It contains important safety and operating instructions for Universal Desk Charger.
2. Before using the battery charger, read all instructions and cautionary markings on (1) the battery charger, (2) the battery, and (3) the product using the battery.
3. **CAUTION** - To reduce the risk of injury, charge only Ericsson battery packs using the proper battery sleeve. Charging any other battery pack or batteries may cause the battery to burst and cause personal injury or damage.
4. Do not expose charger to rain or snow.
5. Do not use auxiliary equipment not recommended or sold by the manufacturer. To do so may result in a risk of fire, electric shock, or injury to persons.
6. To reduce risk of damage to electric plug and cord, pull by the plug rather than the cord when disconnecting the charger.
7. Make sure the cord is located so that it will not be stepped on, tripped over, or otherwise subjected to damage or stress.
8. An extension cord should not be used unless absolutely necessary. Use of an improper extension cord could result in a risk of fire and electric shock. If an extension cord must be used, make sure:
 - a. That pins on the plug of the extension cord are the same number, size, and shape as those on the charger's plug;

TABLE 1
RECOMMENDED MINIMUM SIZE FOR
EXTENSION CORDS

LENGTH OF EXTENSION CORD (Ft.)	25	50	100	150
AWG SIZE OF EXTENSION CORD	18	18	18	16

IMPORTANT SAFETY INFORMATION

- b. That the extension cord is properly wired and in good condition; and
- c. That the wire size is large enough for the AC ampere rating of the charger as specified in Table 1.
9. Do not operate charger with damaged cord or plug - replace them immediately.
10. Do not operate charger if it has received a sharp blow, been dropped, or otherwise damaged in any way; return it to a qualified service shop.
11. Do not disassemble the charger; return it to a qualified service shop when service or repair is required. Incorrect reassembly may result in a risk of electrical shock or fire.
12. To reduce risk of electric shock, unplug the charger from the outlet before attempting any maintenance or cleaning.
13. **GROUNDING AND AC POWER CORD CONNECTION** - To reduce the risk of electrical shock use only a properly grounded outlet. The charger is equipped with an electric cord having an equipment-grounding conductor and a grounding plug. Be sure the outlet is properly installed and grounded in accordance with all local codes and ordinances.
14. **DANGER** - Never alter the AC cord or plug. If it will not fit in the outlet, have a proper outlet installed by a qualified electrician. Improper connection can result in risk of an electric shock .
15. The Rapid Charger 120 Vac line cord has a grounding plug that looks like the plug illustrated in Figure 1. A temporary adapter, which looks like the adapter illustrated in sketches B and C, may be used to connect this plug to a two-pole receptacle as shown in sketch B if a properly grounded outlet is not available. The temporary adapter should be used only until a properly grounded outlet can be installed by a qualified electrician.
16. **DANGER** - Before using an adapter as illustrated, be certain the center screw of the outlet plate is grounded. The green- color rigid ear or lug extending from the adapter must be connected to a properly grounded outlet-make certain it is grounded. If necessary, replace the outlet cover plate screw with a longer screw that will secure adapter ear or lug to outlet plate and make ground connection to grounded outlet.
17. Care should be taken when placing the charger in service to insure proper top and bottom ventilation. A minimum of 1/4" is required between the bottom of the charger and the surface on which it sits.

NOTE

Due to the temperature characteristics of nickel-cadmium batteries, the batteries will not accept a full charge at temperature extremes. For maximum capacity, recharge the battery pack at a room temperature of 65° to 85° Fahrenheit, whenever possible.

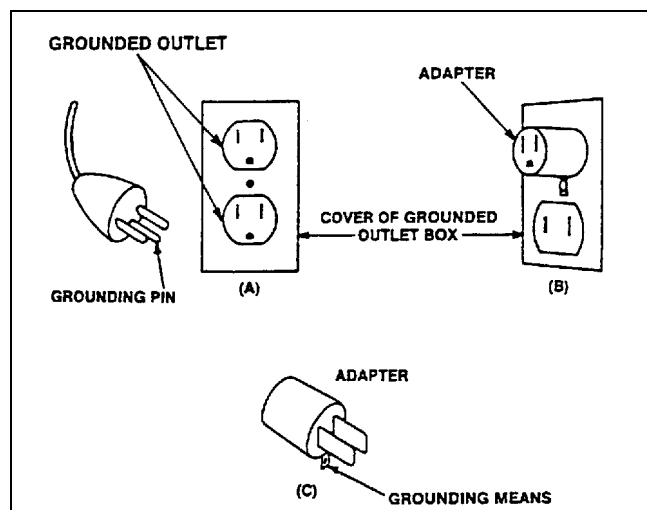

Figure 1 - Grounding Methods

NOTE: The Universal Chargers 344A3072P1 & P8 have been tested and found to comply with the limits for a Class B digital device, pursuant to part 15 of the FCC rules. These limits are designed to provide reasonable protection against harmful interference in a residential installation. This equipment generates, uses and can radiate radio frequency energy and, if not installed and used in accordance with the instructions, may cause harmful interference to radio communications. However, there is no guarantee that interference will not occur in a particular installation. If this equipment does cause harmful interference to radio or television reception, which can be determined by turning the equipment off and

on, the user is encouraged to try to correct the interference by one or more of the following measures:

- Reorient or relocate the receiving antenna.
- Increase the separation between the equipment and receiver.
- Connect the equipment into an outlet on a circuit different from that to which the receiver is connected.

Consult the dealer or an experienced radio/TV technician for help.

DESCRIPTION

The Universal Desk Charger is designed to charge Ericsson personal radio battery packs. The charger has one insert sleeve to securely hold one battery pack. The sleeve has spring loaded electrical contacts to mate with the charging and thermistor contacts on the battery pack. The sleeves are designed so a battery pack alone or attached to a radio can be easily installed or removed from the charger.

The sleeve contains the charging contacts and any circuitry unique to charging a particular family of battery packs. The sleeve is designed to easily plug into the charger base using grooves in the base for self alignment.

Battery Pack sleeves are available for most Ericsson personal radios including M-PA, M-PD, PCS etc. The following listing identifies the sleeve required for each radio.

STANDARD CHARGER

The Standard Desk Charger is powered by a 120/230 Vac power source through the use of a plug-in power transformer called a "Wall Cube" power supply adapter. The charger is capable of fully charging the battery pack in 14 hours.

The charge current for the charger is provided by the "wall cube" step-down transformer. A series resistor, selected by the long or short battery pack microswitch, controls the amount of charge current. A portion of the current flows through the CHARGE LED indicating the battery pack is connected and is being charged.

RAPID CHARGER

The Rapid Desk Charger has a built-in power supply and plugs directly into a 120/230 Vac power source. The charger is capable of charging most battery packs in one hour or less.

<u>PACKAGE</u>	<u>BASE</u>	<u>SLEEVE</u>	<u>CORD</u>
120V M-PA RAPID (CH1RA1)	344A3072P1	344A3072P5	344A3072P10
120V M-PA STANDARD (CH1SA1)	344A3072P2	344A3072P5	344A3072P3
120V PCS RAPID (CH1RS1)	344A3072P1	344A3072P6	344A3072P10
120V PCS STANDARD (CH1SS1)	344A3072P2	344A3072P6	344A3072P3
230V M-PA RAPID (CH1RA2)	344A3072P1	344A3072P5	344A3072P11
230V M-PA STANDARD (CH1SA2)	344A3072P2	344A3072P5	344A3072P4
230V PCS RAPID (CH1RS2)	344A3072P1	344A3072P6	344A3072P11
230V PCS STANDARD (CH1SS2)	344A3072P2	344A3072P6	344A3072P4

The Rapid Charger is microprocessor controlled and uses switching current regulators to regulate the charge current. Battery voltage and temperature are monitored by the microprocessor which controls the **CHARGE** and **READY** LEDs and the charge enable transistor. Input power is applied directly to the switching power supplies. The use of the switching power supplies and feedback current regulation allows the charger to operate at 120 or 230 Vac, 50 or 60 Hz without adjustment.

CAUTION

Recharging any battery pack or batteries other than the ones your equipment was designed to charge may result in damage to equipment, leakage or explosion.

**ACCESSORIES AND
REPLACEMENT PARTS**

The following accessories and replacement parts are available for the Universal Desk Chargers:



120 Vac Wall Transformer
344A3072P3

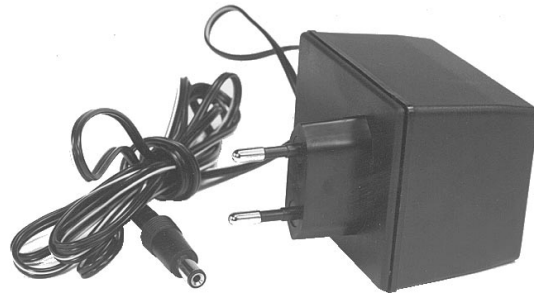

230 Vac Wall Transformer
344A3072P4



120 Vac Wall Transformer
344A3072P10

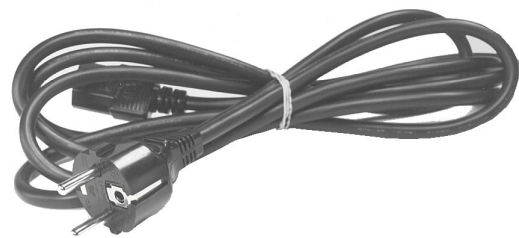

230 Vac Wall Transformer
344A3072P11

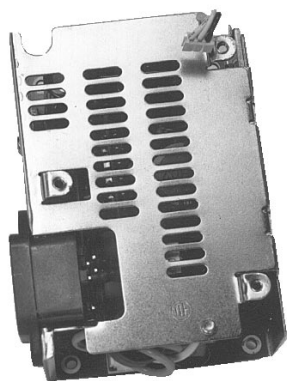

Rapid Charger Power Supply
F29/4R - A9 - 0082

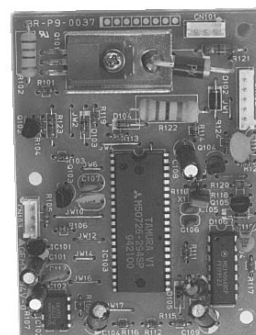

Rapid Charger Control Board
F29/4R - A9 - 0083

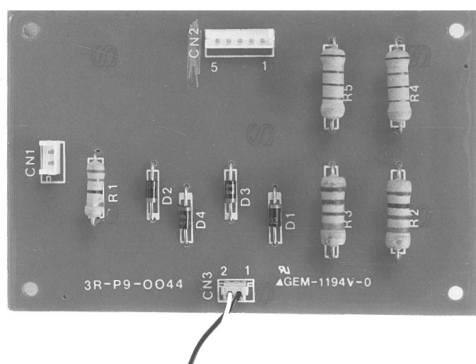

Standard Charger Board
F29/4R - A9 - 0086



Charger Sleeve
M-PA/M-PD 344 A3072P5
PCS 344A3072P6

INSTALLATION

RAPID DESK CHARGER: Locate the Rapid Desk-Charger on a desk or other flat surface near a 120/230 Vac 50/60 Hz source. Plug the power cord into the charger and plug the other end into the outlet. (To insure adequate ventilation, allow for a minimum of 1/4" clearance around the top and bottom covers.)

STANDARD DESK CHARGER: Locate the Standard Desk Charger on a desk or other flat surface near a 120/230 Vac 50/60 Hz source. Connect the plug end of the power cable into the power jack located on the rear of the charger. Plug the "wall cube" power supply end of the power cable into the outlet. (To insure adequate ventilation, allow for a minimum of 1/4" clearance around the top and bottom covers.)

INDICATORS

Standard Desk Charger

CHARGE (RED) CONTINUOUS: Indicates battery is charging at the selected charging rate.

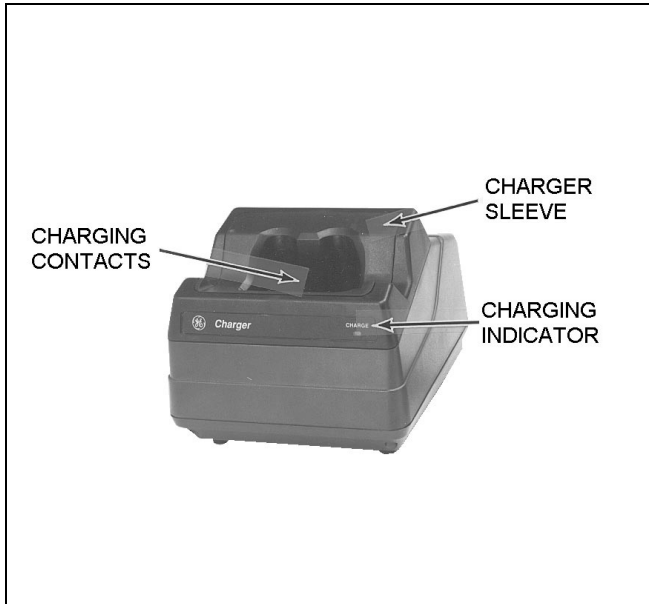

STANDARD DESK CHARGER
(Shown with sleeve installed)

Rapid Desk Charger

WARNING

If both RED and GREEN indicators are blinking fast, immediately unplug the charger and return it for service. If left in this condition the battery may be severely overcharged causing personal injury or damage.

STAND-BY Both indicators are OFF. Battery not installed.

CHARGE (RED) CONTINUOUS: Indicates battery is charging at the selected charging rate.

BLINKS SLOWLY: Indicates a BATTERY FAULT condition which is preventing an acceptable rapid charge. This condition may result if the battery is too hot or cold, weak or dead, or defective. If the

blinking CHARGE indicator does not turn to a continuous RED after 15 minutes, remove and reinsert the battery.

Weak or Dead Battery - The CHARGE indicator goes to continuous RED after the battery has an acceptable precharge (typically less than 10 minutes).

Cold or Hot Battery - The CHARGE indicator stays in a blinking RED condition until the battery temperature reaches acceptable limits and the battery is removed and reinserted to clear the fault condition.

Defective Battery - The CHARGE indicator stays in a blinking RED condition after clearing the fault by removing and reinserting the battery.

READY (GREEN)

CONTINUOUS: Indicates charging is complete and charger has switched to trickle charge.

PROBLEM (RED/GREEN) BLINKING FAST: When both indicators are blinking fast, either the output has a short circuit or an abnormal output condition exists.

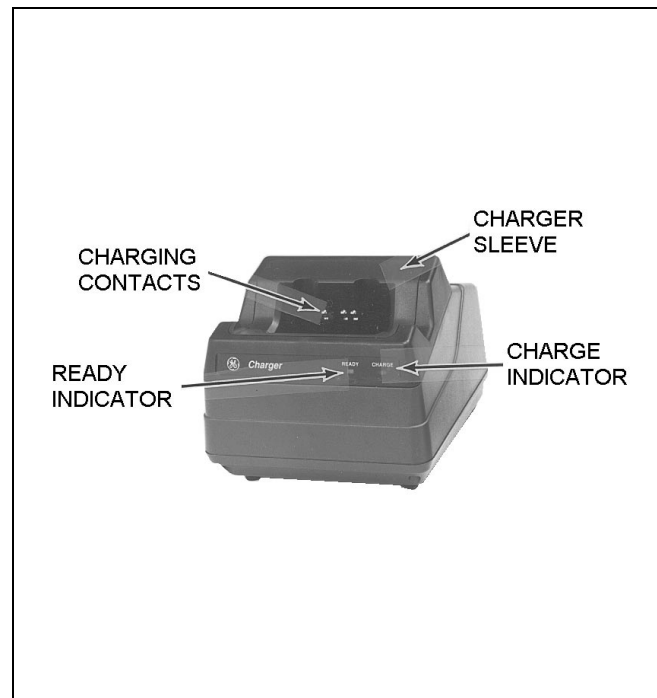

RAPID DESK CHARGER
(Shown with sleeve installed)

OPERATION

To Use The Desk Charger

CAUTION

To reduce risk of injury, charge only nickel-cadmium batteries. Other types of batteries may burst causing personal injury or damage.

1. Turn the radio OFF and place the radio into the charging sleeve with the speaker facing the front of the charger, or properly insert the battery into the charger as indicated on the battery pack (make sure the ON-OFF switch on the battery pack is in the OFF position).
2. **STANDARD DESK CHARGER:** The CHARGE (red) indicator will light indicating the battery is being charged. To charge the battery to maximum capacity, let the battery pack charge for at least 14 hours.
3. **RAPID DESK CHARGER:** The CHARGE (red) indicator will light indicating the battery is being charged. (If the RED indicator is blinking slowly the charger is in the pre-charging mode. This model results if the battery temperature is either too "hot" or "cold", dead or defective, or if the battery is excessively discharged. If the battery is excessively discharged, the charger should switch to normal charge within 10 minutes.)

When the READY (green) indicator lights charging is complete and the charger is in trickle charge mode.

NOTE

On occasion when charging a new battery or a battery which has been out of use for a few months, the charger will prematurely switch to the trickle charge before the battery has been fully charged. If this happens, allow the battery to continue trickle charging overnight. Then remove and reinsert the battery and observe that the battery goes through a normal rapid charge before putting it into service.

To Remove A Battery Pack

Simply reach into the cutouts provided in the sides of the charging insert and lift the battery pack out.

DEFINITIONS

Dead Battery	Battery pack with low voltage due to long-term self discharge or extreme discharge.
Hot Battery	Battery Pack excessively warmed by charging or environmental temperature conditions.
Cold Battery	Battery pack excessively cooled by an environmental condition.
Defective Battery	Battery pack with one or more of the internal cells shorted.

MAINTENANCE

REMOVAL AND REPLACEMENT INSTRUCTIONS

WARNING

To avoid electrical shock, disconnect the charger from the power source before removing or replacing any component or assembly.

Battery Sleeve

Identify the required battery sleeve. To remove or install the sleeve, perform the following steps: (Refer to Figure 2.)

Removal - Use the following instructions to remove a charger sleeve:

1. Turn the charger upside down. Locate the two sleeve screws and remove them using a Phillips screwdriver.
2. Turn the charger right side up and remove the sleeve. This can be done by inserting a couple of fingers into the sleeve cavity and gently pull upward while holding the base down.

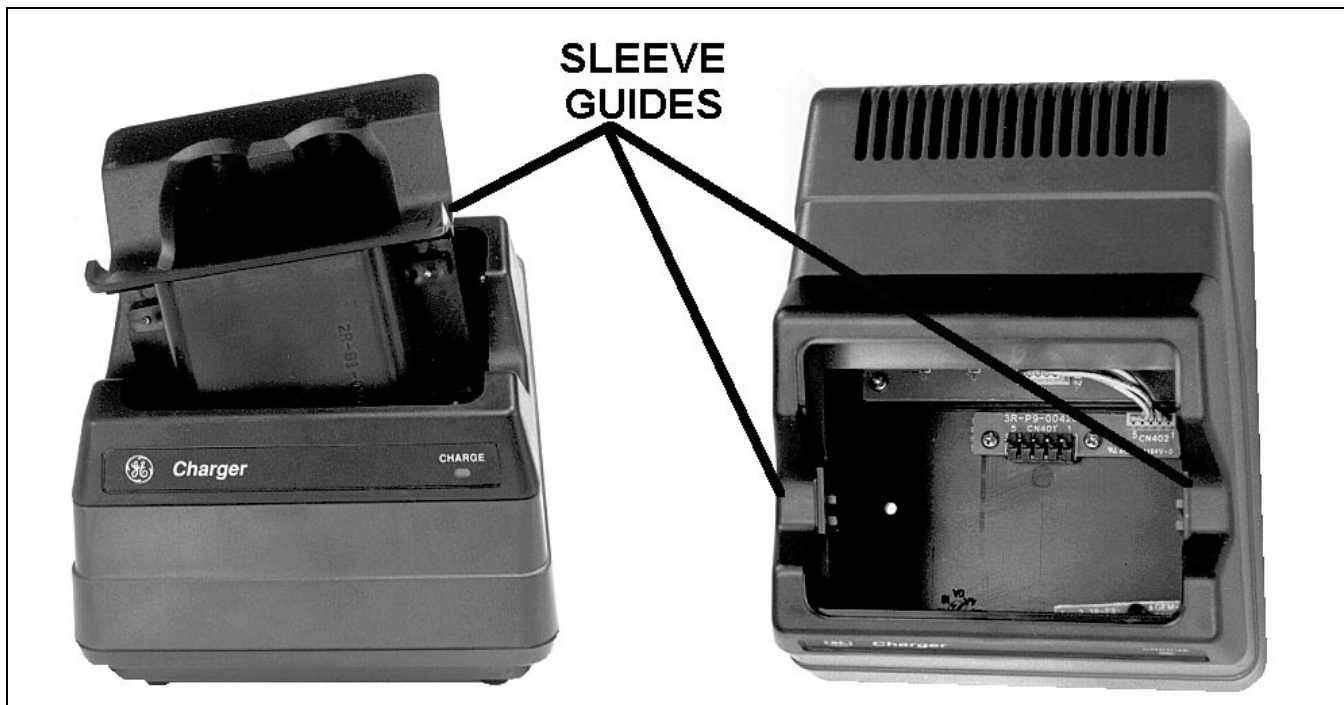

Figure 2 - Sleeve Installation

Installation - Use the following instructions to install a charger sleeve:

1. With the sleeve circuit board facing the rear of the charger, tilt the sleeve slightly forward and insert it into the charger base.
2. Align the sleeve's side molding with the grooves in the charger's base. The sleeve will drop into the base until it meets the connector pins.
3. Press down gently but firmly on the top center of the sleeve until it seats fully into the base. The top of the sleeve will be flush with the top of the base. Do not force the sleeve into the base, the base connector pins will slip into the sleeve connector using a minimum amount of pressure.
4. Turn the charger upside down. Secure the sleeve in the charger base by installing the two sleeve screws.

Standard Charger

Case

Disassembly - Use the following procedures to disassemble the Standard Charger: (Refer to Illustrated Parts Breakdown.)

1. Remove the charger sleeve.
2. Remove four case screws (items 14 & 17). Gently separate the bottom assembly (item 1) from the body (item 2).
3. Disconnect the LED cable (item 8) from connector CNI on the charger board (item 5).

Reassemble:

4. Connect the LED cable to the charger board connector (disconnected in step 3).
5. Reassemble the bottom assembly to the body.
6. Reinstall the four case screws.

Charger Board

To remove the charger board, perform the following steps:

1. Disassemble the charger (see Case disassembly procedure)
2. Remove the two screws (item 21) holding the input power connector.
3. Disconnect the Output PCB cable from connector CN2.

- Remove the two screws (item 18) securing the board and remove the Charger Board from the bottom assembly.

Reinstall:

- Install Charger Board into bottom assembly.
- Install two screws to secure the board (removed in step 4).
- Reconnect the Output PCB cable to CN2.
- Reinstall the input power connector using the two screws removed in step 2.
- Reassemble charger and install battery sleeve.

Rapid Charger

Case

Disassembly - Use the following procedures to disassemble the Standard Charger: (Refer to Illustrated Parts Breakdown.)

- Remove the charger sleeve.
- Remove four case screws (items 23 & 25). Gently separate the bottom assembly (item 1) from the body (item 2).
- Disconnect the LED cable (item 17) from connector CN103 on the Charger Control Board (item 20).

Reassemble:

- Connect the LED cable to the charger board connector (disconnected in step 3).
- Reassemble the bottom assembly to the body.
- Reinstall the four case screws.

Charger Control Board

To remove the Charger Control Board, perform the following steps:

- Disassemble the charger (see Case disassembly procedure).
- Disconnect the Power Supply Cable (item 15) from connector CN101.
- Disconnect the Output PCB cable from connector CN102.
- Remove the three screws with washers (item 35) securing the board to the power supply and remove the Charger Control Board from the bottom assembly.

Reinstall:

- Orient the Charger Control Board on the Power Supply as shown in the Illustrated Parts Break down.
- Install three screws with washers to secure the board (removed in step 4).
- Reconnect the Output PCB cable to CN102.
- Reconnect the Power Supply Cable to CN103.
- Reassemble charger and install battery sleeve.

Power Supply

To remove the Power Supply, perform the following steps:

- Disassemble the charger (see Case disassembly procedure).
- Remove the Charger Control Board (see Charger Control Board removal).
- Remove the two screws (item 30) holding the Power Supply to the bottom assembly (item 1).
- Remove the Power Supply by gently pressing out on the tab surrounding the power connector and lift the Power-Supply out of the bottom assembly. Reinstall:
- Orient the Power Supply power connector with the connector tab on the bottom assembly.
- Align the Power Supply screw holes with bottom assembly screw holes. Press down firmly on the Power Supply until it snaps into place in the bottom assembly.
- Reseat the connector tab around the power connector.
- Reinstall the two screws to secure the Power Supply to the bottom assembly (removed in step 3).
- Reinstall the Charger Control Board.
- Reassemble the charger and install the battery sleeve.

Fuse replacement

To replace the fuse, perform the following steps:

- Remove the battery sleeve (see Battery Sleeve Removal).
- Disassemble the charger (see Case disassembly procedure).
- Remove the Charger Control Board (see Charger Control Board removal procedure).

4. Remove the Power Supply (see Power Supply removal procedure).
 5. Remove the two screws (item 29) on the power connector side of the Power Supply.
 6. Separate the Power Supply Cover (item 6) from the Power Supply Case (item 4) exposing the circuit board (item 18) and fuse F1.
 7. Replace fuse with a like item; Bel Fuse Inc., 5TT1 IA 250V UL/CSA.
 8. Reassemble charger using steps 1 through 6 in reverse order.
1. Check output voltage of the power supply. + 13Vdc 0.5 Vdc at CN2 pin 1.

If the output voltage is out of range, the power supply assembly is defective and must be replaced.

TROUBLESHOOTING PROCEDURES

Rapid Charger

The first step in trouble shooting the Universal Rapid Charger is to make a careful visual inspection of the unit for signs of burning or overheating of components. Also check for loose connections and cracked components. If there is no evidence to indicate the location of the failure, the next step is to troubleshoot by voltage measurements and/or signal tracing. For this purpose, functional diagrams are provided.

QUICK CHECKS:

- Check fuse F1
- Check AC power cord
- Check commercial power line voltage
- Check using a known good battery pack
- Check battery sleeve charging contacts
- Check battery sleeve connections to connector PCB
- Check inside connections between connector PCB and control PCB
- Inspect for cold solder joints, solder bridges or pattern cuts

CHECKING PROCEDURES

The following procedures will aid in isolating failures to field/shop replaceable assemblies. The procedures do not attempt to isolate failures to the component level.

FAULT CONDITION 1: Charger does not charge, as indicated by CHARGE (Red) indicator not lighting.

2. With a known good battery as a load, check the output voltage of the Charge Control assembly. Voltage at CN101 pin 5 should be 6.15Vdc to 10.5Vdc. If the voltage is greater than 10.5Vdc, there is the possibility the battery load is not properly connected to the charge control assembly. Check connections between CN102 pin 5 to the "+" terminal of the charger sleeve, as well as continuity to the battery charging contact. Similarly check for continuity between the ground return CN102 pin 5 and the "-" terminal of the sleeve/battery terminal. Check for dirt on both charger and battery contacts.
3. Check the supply voltage to the CPU. Voltage at IC103 pin 42 should be + 5 Vdc 0.25 Vdc.

This voltage is the output of the regulator circuit contained on the Charge Control Assembly, if the voltage is incorrect the Charge Control PCB must be replaced.

FAULT CONDITION 2: Charger does not charge, as indicated by the CHARGE (Red) indicator flashing at a slow rate.

1. If the battery voltage is below 6.15Vdc, the battery may be either excessively discharged or contains one or more shorted cells. Under these conditions the charge control circuit normally enters a pre-charge mode or trickle charge. If this condition persists with a known good battery and there is continuity between the battery and CN1 01, then a failure in the charge control circuitry is indicated and the PCB must be replaced.

If the battery load is excessively discharged, the charge control assembly is operating correctly by supplying the pre-charge trickle charge to the battery. Under this condition, if the battery is good, the trickle charge will raise the battery voltage above 6.15Vdc in less than 10 minutes. Once the voltage reaches 6.15Vdc, the charger will automatically switch to the normal rapid charge rate which will be indicated by the constant CHARGE (Red) indicator.

2. The flashing CHARGE (Red) indicator is also used to indicate battery temperature outside the acceptable range for rapid charging. This indication results from the following sequence: After the excessively hot or cold battery is inserted into the sleeve, the CHARGE (Red) indicator remains ON for an approximate 10 seconds, (which indicates normal battery voltage), and then goes into the flashing mode.

Upon insertion of the battery into the charger, the charge control circuitry measures the resistance of the internal

battery thermistor, via the connection from CN102 pin 3 through inter-connecting cables/PCB to the thermistor contact on the sleeve. With a known good battery at room temperature (25 °C), the thermistor resistance is approximately 50 K Ohms. If the CHARGE (Red) indicator is flashing with a room temperature battery in the sleeve, check for continuity or shorts from the battery contact to CN102 pin 3. If there is continuity, then either IC104 or IC103 is defective or there is a PCB pattern problem, which necessitates replacement of the Charge Control PCB.

FAULT CONDITION 3: Charger's CHARGE (Red) Indicator flashes with no battery in the sleeve (Stand-by condition).

This fault condition can be verified by checking voltage between CN102 pin 4 and pin 5, with no battery in the sleeve. If this voltage is 0 volts, there is probably a PCB run problem between R122 and D102. If the voltage is approximately 12.6 Vdc, check IC103 pin 9. This voltage is generated by a regulator IC101 located on the PCB and should be approximately 5 Vdc. If this voltage is not present the Charge Control PCB must be replaced. If the regulated voltage is correct, then the re-set circuitry IC 102 has failed which requires replacement of the Charge Control PCB.

FAULT CONDITION 4: Both CHARGE (Red) and READY (Green) indicators flash simultaneously.

The probable cause of this fault condition is shorted components QIOI and DIOI, or defects in Q103 and Q102. This failure requires replacement of the Charge Control PCB.

FAULT CONDITION 5: Irregular flashing of CHARGE (Red) indicator after the charge sequence has started.

This condition results when the voltage sense circuit detects an excessively high voltage across the battery which is the result of charging. Normal batteries do not exceed the 10.5 V limit. The battery should be replaced with a known good battery. If normal operation results, the battery is defective. If the problem persists, the voltage detection of the PCB has failed, which requires replacement of the Charge Control PCB.

FAULT CONDITION 6: Excessive battery temperature resulting from overcharge due to failure to detect minus delta V.

If the charge control circuit fails to detect minus delta V, the battery can be excessively overcharged which results in high battery pack temperature. Under normal operation, the battery over temperature detect circuit would prevent excessive over charge. Additionally, the watch dog timer would terminate over charge based on time. The failure to correctly terminate rapid charge by any of the above three methods indicates failures of either the charge

control microprocessor IC 103, analog switch IC104, or the watch dog timer IC102. Any of these failures require replacement of the Charge Control PCB.

FAULT CONDITION 7: Premature termination of rapid charge prior to full charge. Indication is flashing READY (Green) indicator.

This failure mode is the result of the charge control circuit detecting a minus delta V condition early in the charging cycle. This condition is the result of a marginal battery or a battery which has limited capacity and is close to the end of its life. The battery should be discarded and replaced with a known good battery.

FAULT CONDITION 8: Extended charge time when charging a "long battery, without overheating.

When charging a long battery, the battery length microswitch, located at the bottom of the charging sleeve, detects the battery length which provides the correct rate of rapid charge. If the microswitch is defective or there is an open between the switch and the Charge Control Assembly, the charge control circuit may be charging at the low level rapid charge (1.3 A 10%) instead of the correct level of (1.9 A 10%). Total charging current should be checked by measuring current in the negative (-) path.

Standard Charger

The first step in trouble shooting the Universal Standard Charger is to make a careful visual inspection of the unit for signs of burning or overheating of components. Also check for loose connections and cracked components. If there is no evidence to indicate the location of the failure, the next step is to troubleshoot by voltage measurements and/or signal tracing. For this purpose, functional diagrams are provided.

QUICK CHECKS:

- Check AC power cord
- Check commercial power line voltage
- Check using a known good battery pack
- Check battery sleeve charging contacts
- Check battery sleeve connections to connector PCB
- Check inside connections between connector PCB and control PCB
- Inspect for cold solder joints, solder bridges or pattern cuts

CHECKING PROCEDURES

The following procedures will aid in isolating failures to field/shop replaceable assemblies. The procedures do not attempt to isolate failures to the component level.

The charge control circuitry of the Standard Desk Charger is located on the Standard Charger Board. This board receives low voltage AC from the wall cube transformer. This AC supply is converted to DC by a full wave bridge rectifier consisting of D1, D2, D3, and D4. The charging current results from the current limiting resistors R2, R3, R4, and RS and the battery length microswitch SW301.

If the charger is not charging properly, first check the AC input voltage from the wall transformer. AC voltage at J1 should be 17.5 Vdc 10%. If the charger has the proper AC input at CN3 and continuity confirms correct connections between CN2 and the charging contacts on the battery, the failure is on the standard Charger Board which must be replaced.

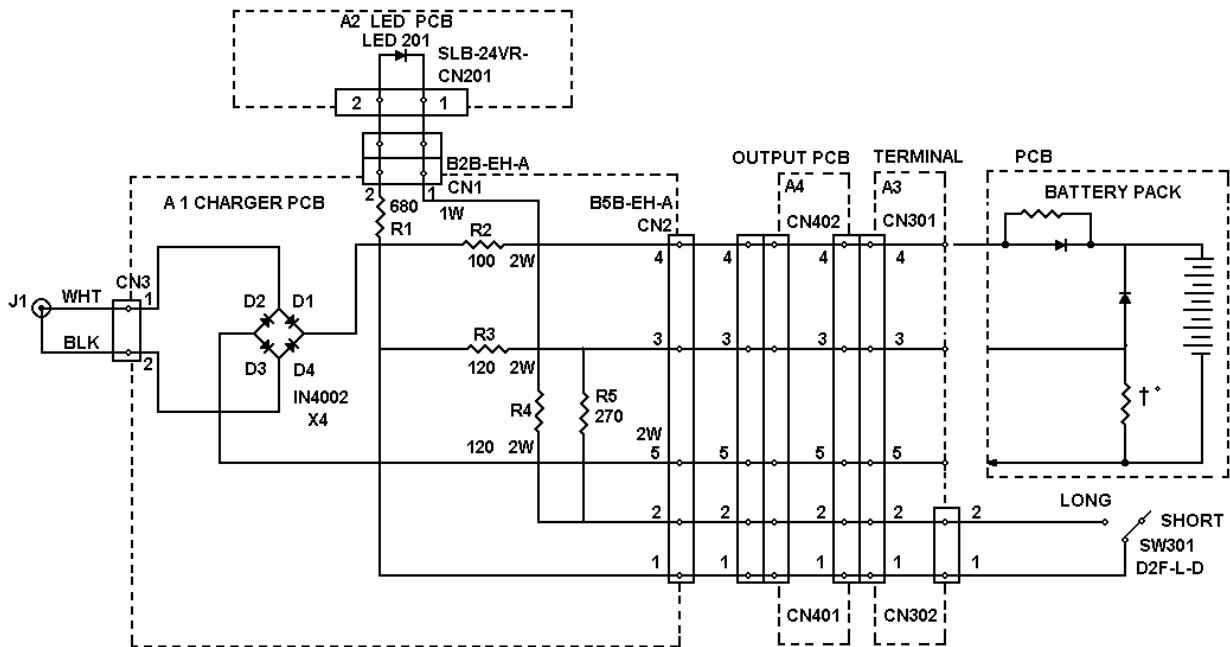

STANDARD CHARGER - 344A3072P2
CHARGER BOARD - F29/4R-A9-0086

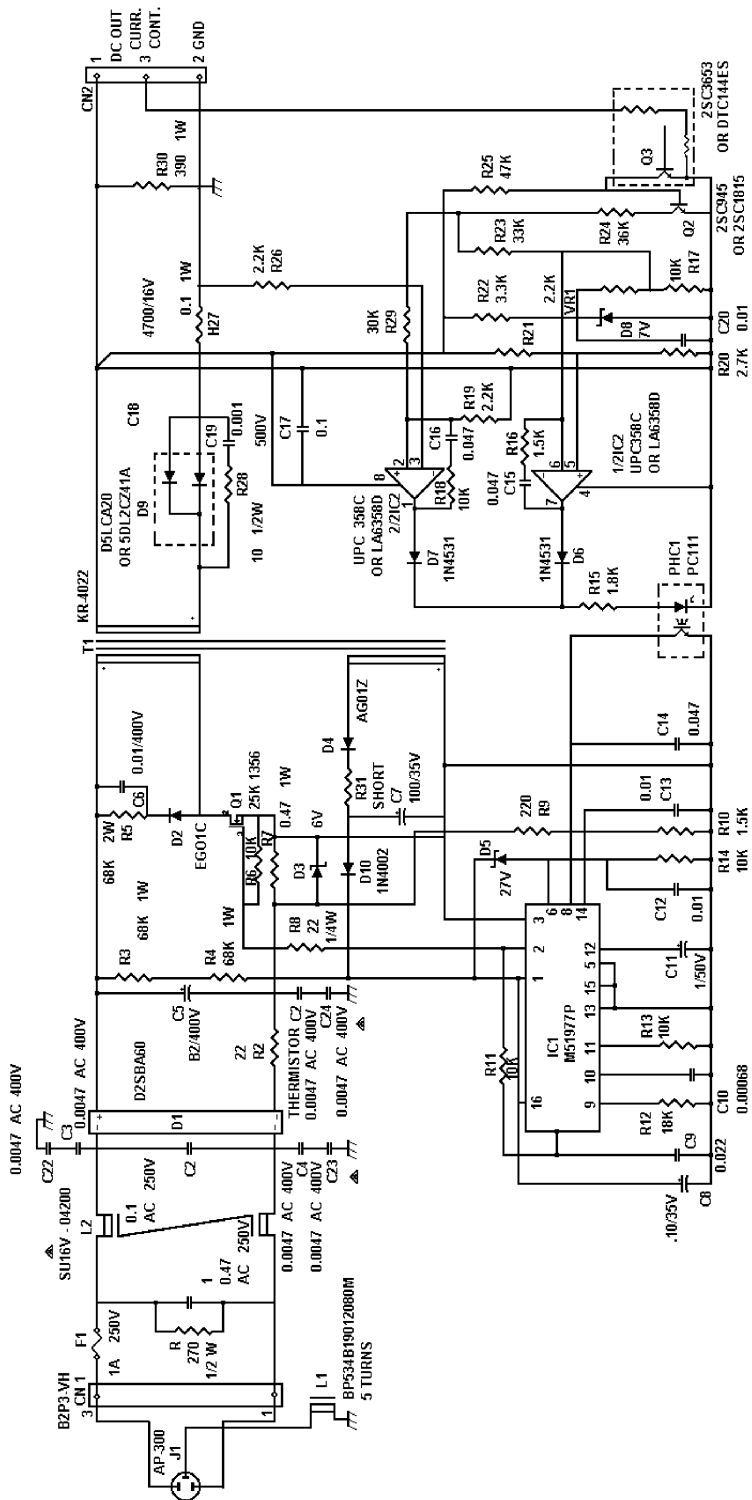

**RAPID CHARGER - 344A3072P1
POWER SUPPLY BOARD**

(part of F29/4R-A9-0082)
(3R-M5-0017)

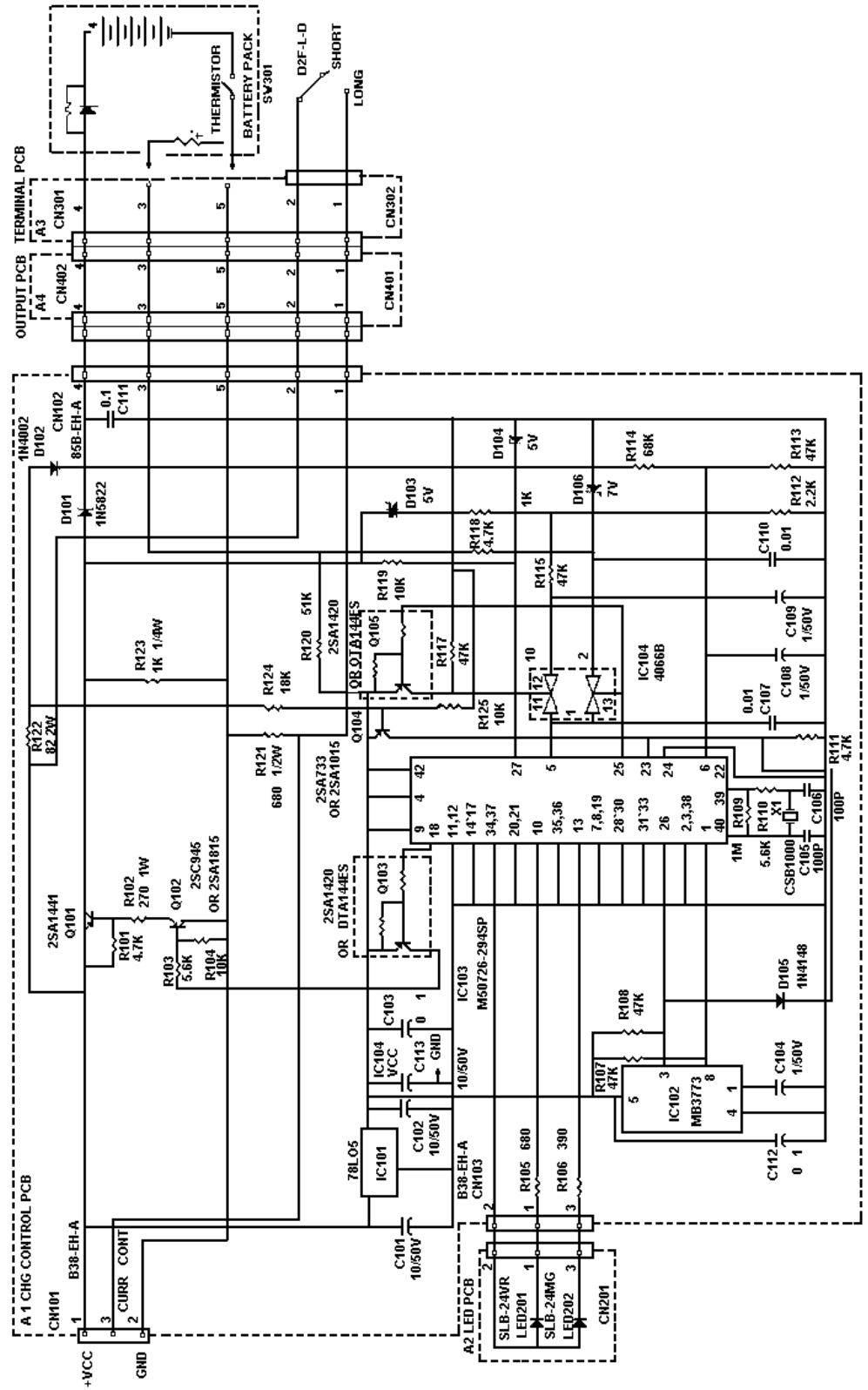

**RAPID CHARGER - 344A3072P1
CONTROL BOARD - F29/4R-A9-0083**

(2R-M5-0018A)

PARTS LIST

UNIVERSAL DESK CHANGER
RAPID MODEL - 344A3072P1
ISSUE 1

SYMBOL	PART NO.	DESCRIPTION
1	F29/4R-A9-0085	Cabinet Bottom Assembly.
2	F29/2R-B1-0098	Cabinet Body.
3	F29/4R-A9-0084	Cabinet Top Assembly.
	F29/4R-A9-0082	Power Supply Assembly.
4		Power Supply Case (part of F29/4R-A9-0082).
5		Insulator (part of F29/4R-A9-0082).
6		Power Supply Cover (part of F29/4R-A9-0082).
7		Heat Sink (part of F29/4R-A9-0082).
8		Transistor holder (part of F29/4R-A9-0082).
9		AC connector (part of F29/4R-A9-0082).
10		Connector Harness (part of F29/4R-A9-0082).
11	F29/4R-N4-0064	Identification insert.
12		Ferrite core (part of F29/4R-A9-0082).
13		Ground wire (part of F29/4R-A9-0082).
14		Transistor insulator (part of F29/4R-A9-0082).
15	F29/4R-M7-0043	Connector Harness.
16	F29/4R-M7-0042	Connector Harness.
17	F29/4R-M7-0044	Connector Harness.
18		Power Supply printed circuit board (part of F29/4R-A9-0082).
19	F29/3R-P9-0041	LED printed circuit board.
20	F29/4R-A9-0083	Charge Control printed circuit board.
21		Insulator (part of F29/4R-A9-0082).
22	F29/4R-B5-0011	Foot.
23		Screw, self tapping, 3x25 BZ.
26		Screw, self tapping, 3x10 BZ.
27		Screw, self tapping, 3x15 BZ.
28		Screw, self tapping, 3x6 ZC.
29		Screw with washer, M3x12 ZC.
30		Flathead screw, M3x6 ZC.
31		Bindhead screw, M3x4 ZC
32		Screw with washer, M4x8 ZC.
33		Screw, self tapping, 3x8 ZC.
34		Screw, self tapping, 3x8 ZC.
35		Screw with washer, M3x6 ZC.
36		Caution label.
37		Rating label.

*COMPONENTS ADDED, DELETED OR CHANGED BY PRODUCTION CHANGES

PARTS LIST

UNIVERSAL DESK CHANGER
RAPID MODEL - 344A3072P2
ISSUE 1

SYMBOL	PART NO.	DESCRIPTION
1	F29/4R-A9-0088	Cabinet Bottom Assembly.
2	F29/2R-B1-0098	Cabinet Body.
3	F29/4R-A9-0087	Cabinet Top Assembly.
4	F29/3R-D9-0042	Output printed circuit board.
5	F29/4R-A9-0086	Charger Board
6	F29/3R-P9-0041	LED printed circuit board.
7		DC Jack.
8	F29/4R-M7-0045	Connector Harness.
9	F29/4R-N4-0064	Identification Insert.
10		Label.
11	F29/4R-M7-0042	Connector Harness.
12	F29/4R-M7-0046	Connector Harness.
13	F29/4R-B5-0011	Foot.
14		Screw, self tapping, 3x15 BZ.
15		Screw, self tapping, 3x10 BZ.
16		Screw, self tapping, 3x6 BZ.
17		Screw, self tapping, 3x25 BZ.
18		Screw, self tapping, 3x8 ZC.
19		Screw, self tapping, 3x8 ZC.
20		Screw, self tapping, 3x8 ZC.
21		Screw, self tapping, bind head, 3x8 ZC.

*COMPONENTS ADDED, DELETED OR CHANGED BY PRODUCTION CHANGES

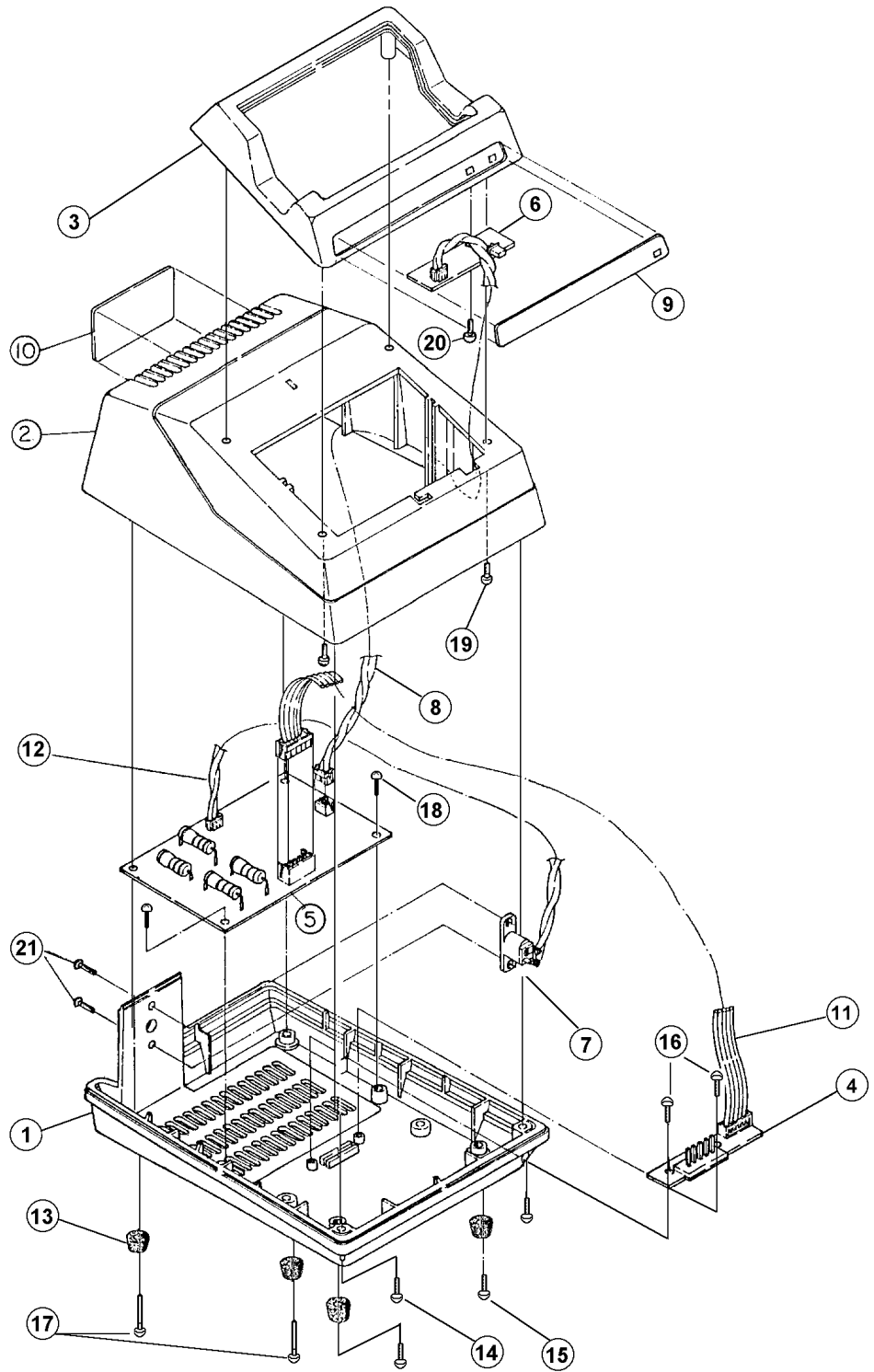

STANDARD CHARGER - 344A3072P2

(3R-K5-0016)

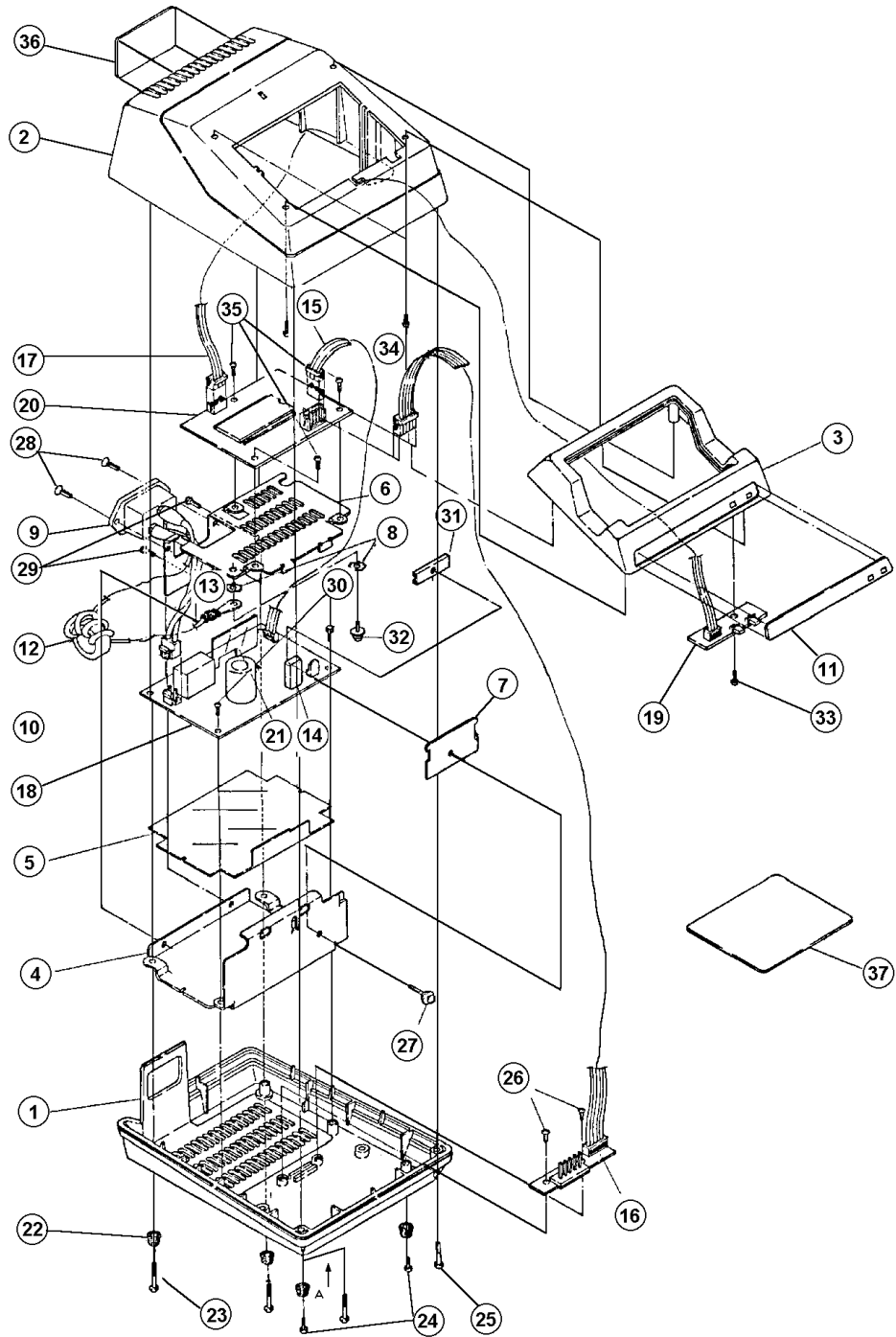

RAPID CHARGER - 344A3072P1

(2R-K5-0015)

This page intentionally left blank

Ericsson Inc.
Private Radio Systems
Mountain View Road
Lynchburg, Virginia 24502
1-800-528-7711 (Outside USA, 804-528-7711)

Printed in U.S.A.