



MAINTENANCE MANUAL FOR 806-869 MHz PERSONAL TWO-WAY FM RADIO COMBINATION

TABLE OF CONTENTS

	<u>Page</u>
INTRODUCTION	1
PHASE 1 : RADIO SECTION TROUBLESHOOTING	
Functional Troubleshooting Flow Chart	3
Synthesizer	
Flow Chart	4
Troubleshooting for Synthesizer	4
Receive	
Flow Chart	8
Troubleshooting for Receiver	8
Transmit	
Flow Chart	11
Troubleshooting for Transmitter	11
PHASE 2 : LOGIC SECTION TROUBLESHOOTING	
Major Troubleshooting flow chart	13
Functional Troubleshooting	
Flow chart	13
Troubleshooting for Logic Section	14
LOGIC SECTION CHECK LIST	16
TRACKING DATA	21
MAINTAINING WEATHER PROOF INTEGRITY	21
MODULE AND INTERGRATED CIRCUIT CATA	22

INTRODUCTION

The recommended troubleshooting procedure, as illustrated in Figure 1, is to isolate the fault to a specific section of the M-RK Personal radio ; the radio section ; the logic section or the battery pack. Then further localize the fault to a specific stage of the suspected section. The last step is to isolate and identify the defective component.

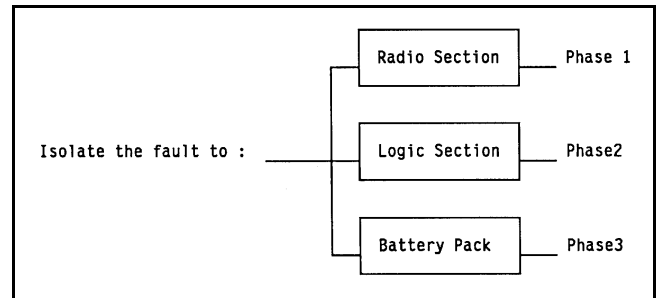

Figure 1 - Recommended Troubleshooting Procedure

The following list of test equipment is recommended when servicing or troubleshooting the M-RK Personal Radio.

Recommended Test Equipment :

- Audio Analyzer
- Digital Voltmeter
- DC Power Supply
- Multimeter
- Oscilloscope

Servicing Setup

The servicing setup is shown in Figure 1A. This illustrates the test boxes, cables, etc. required when the M-RK needs to be disassembled for troubleshooting or servicing.

Maintenance/Warranty

1. Repair and Return is available at authorized General Electric Service Stations (GESS) or at Ericsson GE Mobile Communications Inc., in Lynchburg, VA.

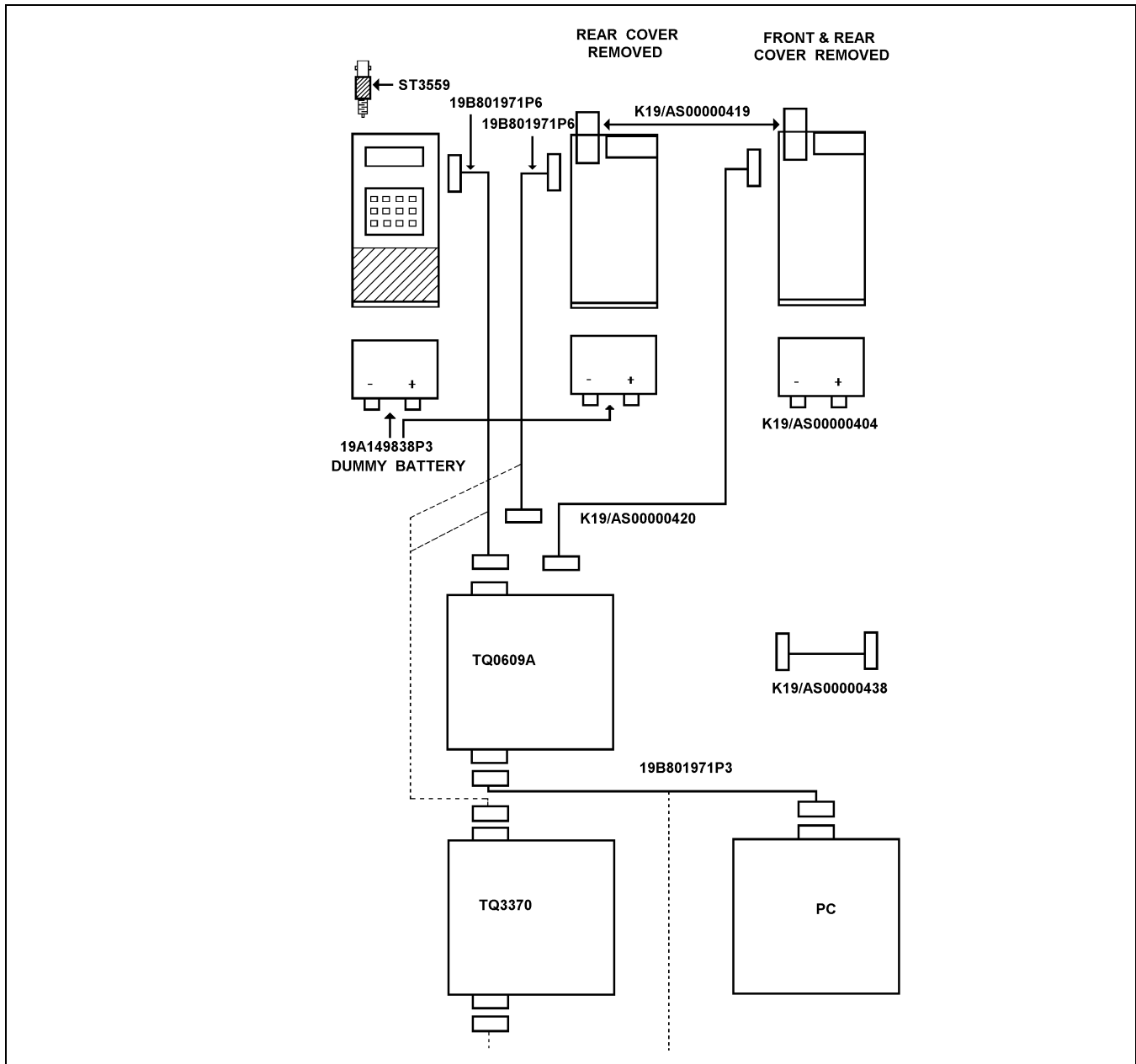

Figure 1A - Servicing Setup

2. Board level Repair and Return is recommended. Servicing to component level is not recommended.
3. Parts and components available through Service Parts are shown and listed in LBI-38746. When ordering replacement parts, please add the prefix "K19/" to the listed part number.
4. Standard warranty (3 months labor, 12 months parts) applies. Option PKCSIP extends labor warranty to 12 months.

PHASE 1 : RADIO SECTION TROUBLESHOOTING

Functional Troubleshooting

Once the fault has been isolated to the radio section, the next step is to further isolate the fault to a specific stage of the radio section; Frequency Synthesizer (SYN), Receive (RX) and Transmit (TX). The flowchart (See Page 2) will assist in isolating the fault to a specific stage of the radio section.

Functional Troubleshooting Flowchart:

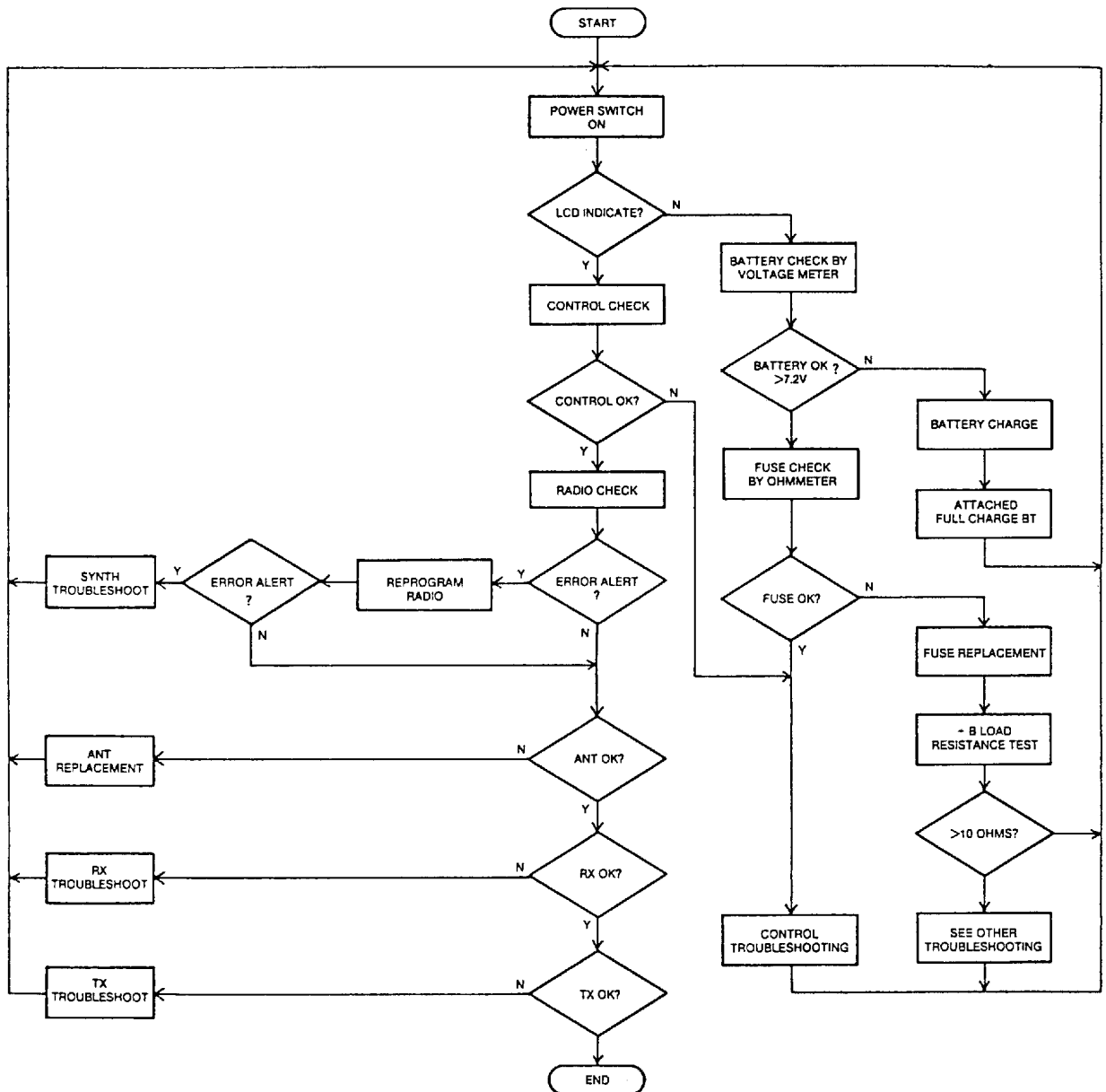

SYNTHESIZER

The following flowchart can be used to isolate a defective stage in the synthesizer circuit.

Synthesizer Flowchart :

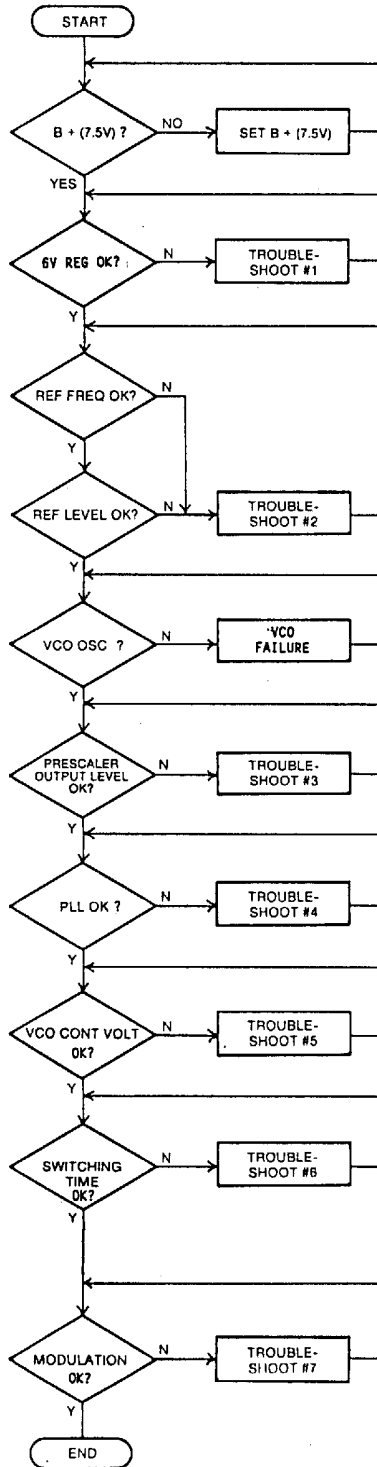

Troubleshooting for the Synthesizer :

1. 6.0 Volt Regulator

The 6.0 volt regulator consists of regulator U6 and transistor Q105. If a fault is found with the regulated 6.0 volt output line, trace the fault source along this line back to the regulator. A typical current flowing is 30 mA. Typical voltages for the synthesizer are shown in Table 1.

Any repair should be made so that the current and voltage at each assembly and component agrees with the typical value.

2. Reference Oscillator VCTCXO (Z1)

The reference oscillator is contained in one assembly. Typical data, when the reference oscillator is working properly, is shown in Table 2.

Table 2 - Typical Data For The Reference Oscillator

Item	Typical Value	Remarks
Supply Voltage	5.3 Vdc	
Current Drain	1.5 to 1.8 mA	
Output Frequency	13.2 MHz	
Output Level	1 to 2 Vp-p	

3. Prescaler Output Level

VCO U5 has an output level of about 0 dBm. Part of the VCO output is applied to the input of buffer amplifier transistor Q101 through a capacitor. After amplification, the output is applied to the input of the Prescaler, which is operating under 128/129 modulus control. A typical prescaler output level is 1 volt p-p, which is applied to the input of the PLL.

When checking the prescaler, refer to the typical value on Table 1.

4. Phase-Lock-Loop (U2)

- a. Check for approximately 1 to 2 volts p-p reference signal input at Pin 2 of U2.
- b. Check that the reference signal frequency is 13.2 MHz and that frequency stability is ± 1.5 PPM.

- c. Measure the input from the prescaler at Pin 10 of U2 and verify approximately 1 volt p-p input level.
- d. Verify that approximately 5 volts p-p (Vss-Vcc) control pulse is present at Pin 8 of prescaler control U2.
- e. Cause the PLL to unlock. Then check for the presence of approximately 5 volts p-p (Vss-Vcc) PD and FD pulse outputs at Pin 6 and Pin 17 of U2 respectively. Also check for approximately 6 volts p-p (Vss+B) at Pin 1 of U4. If the pulse output is absent or shifted to either the Vss or the Vcc side, the PLL may fail to lock over a certain section of the frequency range or the entire range. If this fault occurs, the possible trouble source is ramp resistor R111, ramp capacitor C131 or hold capacitor C132.
- f. Verify that the local voltages at the test points listed on Table 1 agree with the typical values also listed on Table 1.
- g. Verify that the CLOCK, DATA, ENABLE and WIDE/NARROW signals coming from the Control Board are at the proper level and the proper duration (refer to Figure 2).

If the CLOCK and DATA are improper, the PLL operation will become erratic. If the duration of the W/N pulse is shorter than 10 milliseconds, which is the minimum value, the PLL may fail to lock.

NOTE

If parts other than those specified in the parts list are used in the associated circuit of the PLL, the switching time may be affected. Whenever any parts are replaced in the associated circuit, check the switching time.

Table 1 - Synthesizer Portion Typical Voltages

No.	Test Points	Voltage (V)	Remarks
1	U1 (1)	3.0	
2	U1 (2)	5.3	
3	U1 (3)	0 (GND)	
4	U1 (4)	1.2p-p	V _L : 3.2, V _H : 4.4
5	U1 (5)	0 (GND)	
6	U1 (6)	4.8p-p	V _L : 0.6, V _H : 5.4
7	U1 (7)	—	
8	U1 (8)	3.0	
9	U2 (1)	4.0	
10	U2 (2)	1.6p-p	V _L : 1.6, V _H : 3.2
11	U2 (5) (19)	5.6	
12	U2 (6) (17)	1.4(RX), 1.2(Tx)	at 806 MHz
13	U2 (8)	4.8p-p	V _L : 0.6, V _H : 5.4
14	U2 (9)	5.5	
15	U2 (10)	1.2p-p	V _L : 1.8, V _H : 3.0
16	U2 (11)	0	
17	U2 (12)	0	
18	U2 (13)	0	
19	U2 (15)	2.1o-p(Rx), 1.9o-p(Tx)	at 806 MHz
20	U2 (18)	0.2p-p	V _L :2.4,V _H :2.6(Rx), V _L :2.1,V _H :2.3(Tx),
21	U2 (20)	3.9	
22	Z1 (3)	4.9	
23	U4 (1)	1.9(Rx), 1.6(Tx)	at 806 MHz
24	U4 (2)	1.5(Rx), 1.2(Tx)	
25	U4 (3)	1.4 (Rx), 1.2(Tx)	at 806 MHz
26	U4 (4) (5)	0 (GND)	
27	U4 (6)	0 (GND)	
28	U4 (7)	—	
29	U4 (8)	7.4	

No.	Test Points	Voltage (V)	Remarks
30	U3 (9) (10)	1.9(Rx), 1.6(Tx)	at 806 MHz (Hi impedance)
31	U3 (9) (10)	1.9(Rx), 1.6(Tx)	at 806 MHz
32	U3 (6) (12)	0	
33	U3 (5) (13)	0 (GND)	
34	U3 (7)	0 (GND)	
35	U3 (2) (3)	0 (GND)	
36	U3 (1) (4)	0 (GND)	
37	U3 (14)	6.0	
38	U5 (1)	0.1 (Rx), 3.9(Tx)	
39	U5 (3)	0	
40	U5 (4)	5.2	
41	U5 (5)	0	
42	U5 (7)	5.0(Rx), 1.6(Tx)	
43	U5 (10)	5.1	
44	U5 (12)	1.9(Rx), 1.6(Tx)	at 806 MHz (Hi impedance)
45	U5 (2) (6) (8) (9) (11) (13) (14)	0 (GND)	
46	Q101 Base	1.0	
47	Q101 Emitter	0.3	
48	Q101 Collector	6.0	
49	Q102 (1)	5.0 (Rx), 0.2(Tx)	
50	Q102 (2) (3)	0.1(Rx), 3.9(Tx)	
51	Q102 (4)	5.0 (Rx), 0(Tx)	
52	Q103 (5) (6)	0 (GND)	
53	Q103 Base	1.2	
54	Q103 Emitter	0.6	
55	Q103 Collector	6.7	
56	Q105 (1)	0 (GND)	
57	Q105 (2)	7.5	
58	Q105 (3)	0	

No.	Test Points	Voltage (V)	Remarks
59	Q106 Base	5.8	
60	Q106 Emitter	5.2	
61	Q106 Collector	6.0	
62	Q107 Base	7.4	
63	Q107 Emitter	6.8	
64	Q107 Collector	7.5	

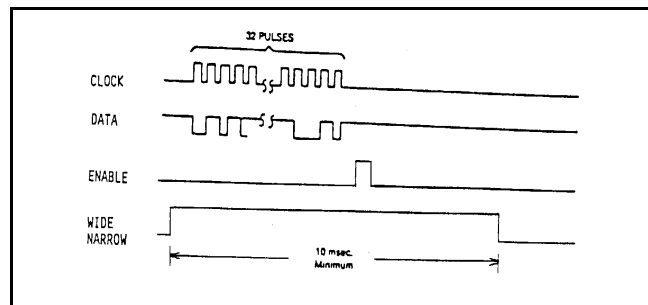

Figure 2 - Clock, Data, Enable, and Wide/Narrow Signals

5. VCO Control Voltage

a. VCO Control Voltage should be :

- Approximately 1 volt or more at the lowest channel of any band.
- Approximately 4.5 volts or less at the highest channel of any band.

Verify the VCO control voltage at the testpoint TPPD using a high-impedance oscilloscope.

6. Switching Time

The channel frequency must be locked within 10 milliseconds, which is the duration of the Wide/Narrow pulse. That is, the switching time is restricted by the Wide/Narrow pulse.

- a. Switching time is largely influenced by the leakage current characteristics of C133 and C152. Be sure to use parts having the ratings specified on the Parts List when replacing these parts. Also, if moisture collects on the printed wire board, the Insulation resistance of the board may be lowered, also affecting the switching time.

- b. The channel switching sequence and the action of the related functions are shown in Figure 3.

7. Modulation Degree vs Modulation Flatness :

The M-RK equipment can be modulated with audio beginning with 10 Hz. For this reason, the same modulation signal is applied to both VCO and VCTCXO in phase. The modulation signal of low frequencies below 10 to 30 Hz, modulates the VCTCXO output whereas the high frequency signals modulate the VCO. Modulation characteristics can be adjusted using modulation adjustment controls R120 and R121 as follows :

NOTES

1. Adjust modulation flatness with the radio section only.
2. For this adjustment, select the center channel.

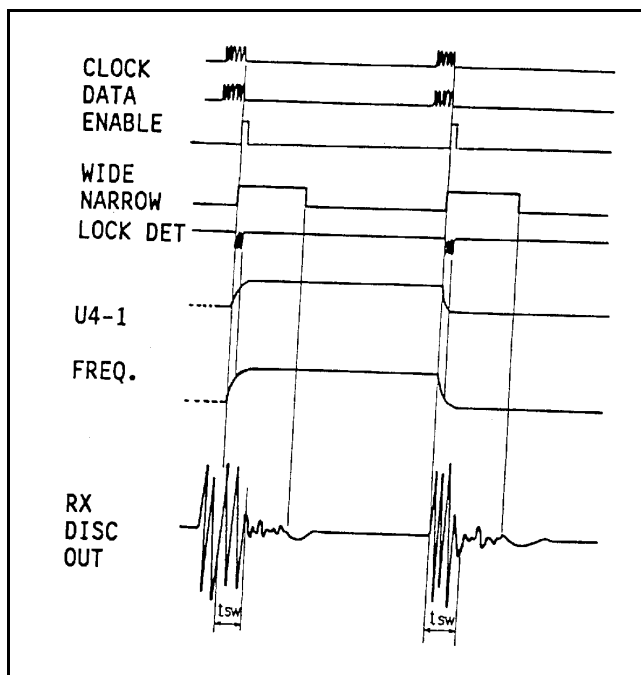

Figure 3 - Channel Switching Sequence

1. Apply 0.45 Vrms/1 kHz signal at the TX audio terminal and adjust R121 for 2.4 kHz deviation.
2. Change the signal frequency to 10 Hz. Adjust R120 for a 2.4 kHz deviation.

3. Change the signal to a 10 Hz rectangular waveform signal. Then, the demodulated output from the modulation analyzer should look like Figure 4. If the level adjustments under step 1 and 2 are out of balance, the rectangular waveform will be distorted (refer to Figure 4).

NOTE

For this test, the modulation analyzer must have low frequency response to less than 1 Hz.

4. Change the carrier frequency to the highest channel of the band and then to the lowest channel. Check the modulation flatness each time (refer to Figure 5).

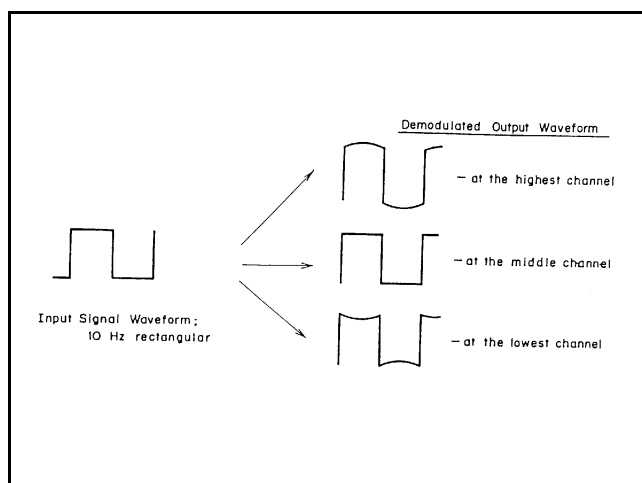

Figure 4 - Typical Rectangular Waveform of Demodulated Output

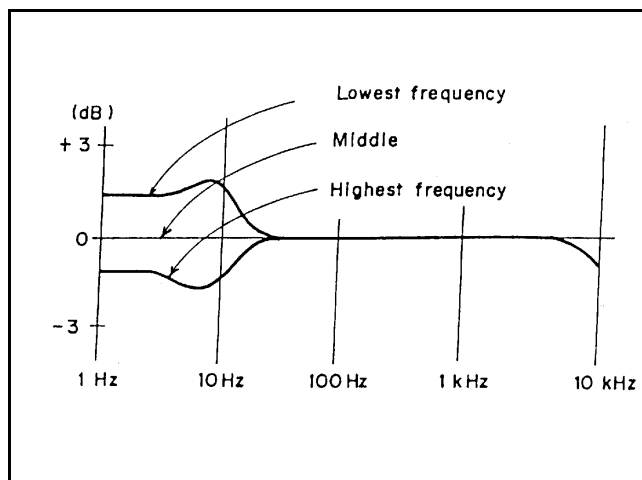

Figure 5 - Typical Frequency Characteristics

If a large level difference is found between the modulation characteristics at 10 Hz and those at 100 Hz when the carrier frequency is changed from the highest to the lowest, the problem is with the VCO modulation characteristics.

When the waveform of the demodulated output is distorted for a modulation frequency of 10 Hz or lower, the problem is with the VCTCXO. If the distortion is substantial, the carrier frequency may be affected by modulation.

Receive

The following flowchart can be used to isolate a defective stage in the receive circuit.

Flowchart :

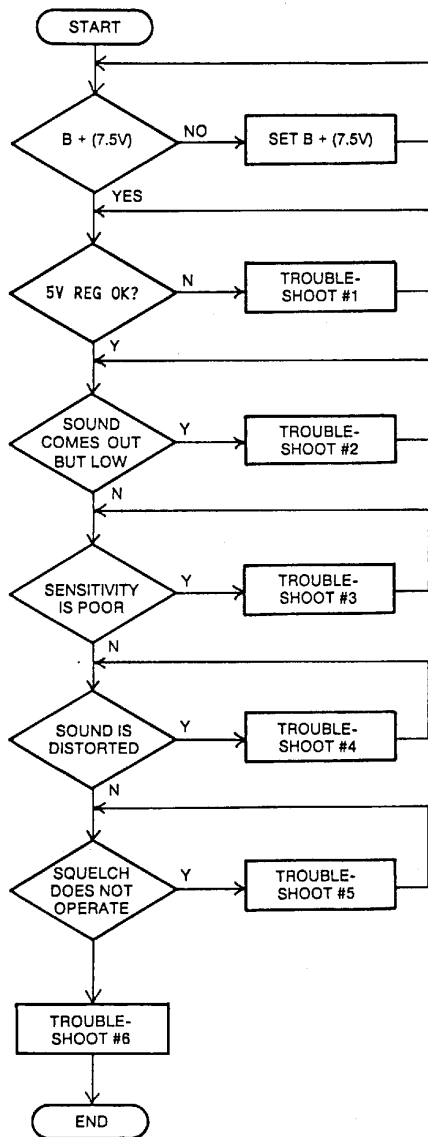

Troubleshooting for the Receiver :

1. Measure the voltage of U10 input and output. If the voltage of U10 input is 7.5 V and the voltage of U10 output is not $5 \pm 0.2V$, U10 (voltage regulator) is probably no good.
2. If sound comes out of the receiver, but the volume does not increase, the problem may be due to either the Radio section or the Logic section.
 - a. Radio Section : Check the output signal for about 280 mVp-p at the audio terminal of the RX section (J1 Pin 3B) when a standard modulated signal (1 kHz at 2.4 kHz frequency deviation) of 0.5mV (-53 dBm) is supplied at the antenna terminal or UDC RF Connector. If the signal level at the audio terminal of the RX is substantially low after return R312, IC U11 is suspected to be defective.
 - b. Control Board : The receive RF signal comes into P1 , Pin 3B. The signal is then applied through a 14dB amplifier, 300-3000Hz BPF, Deemphasis and a 44 dB volume level control. The signal is then amplified by SPK amplifier U11 to drive the speaker. Typical levels needed to obtain a 1 kHz, 0.5 watt receive rated audio output are shown in Figure 6.
3. When receive sensitivity is poor, refer to the radio section Schematic Diagram : A2WE05282 and typical voltages shown on Table 3. The receive section consists of low noise amplifier Q301, local oscillator amplifier Q103, IF amplifier Q302 and second IF circuit IC U11.
 - a. Level Diagram : A Frequency Relationship Diagram is shown in Figure 7 and a Typical Level Diagram is shown in Figure 8.
 - b. Adjustments :
 - (1) C318 is provided for the adjustment of the second local oscillator.
 - (2) When the desired channel frequency with standard modulation is applied to the antenna terminal, adjust C323 for maximum output at RX Audio.

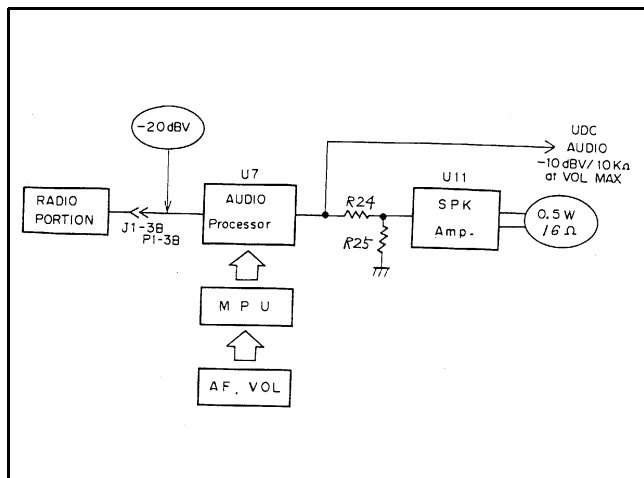

Figure 6 - Receive Audio Output

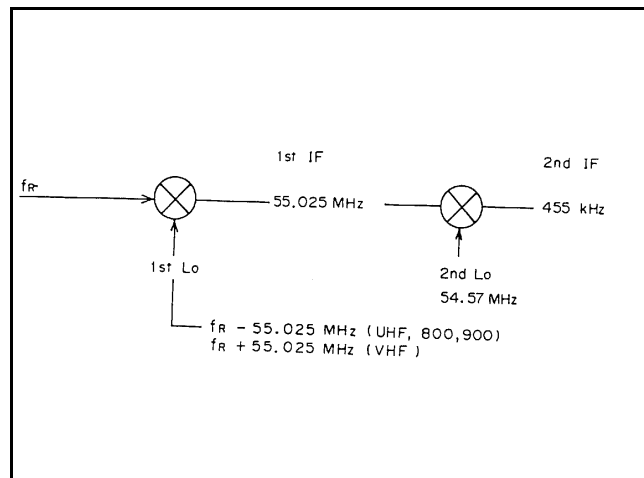

Figure 7 - Frequency Relationship Diagram

(3) Adjustment of L304 and L306

- (a) Adjust L304 and L306 in this order to obtain the best SINAD sensitivity.
- (b) Next, adjust L304 and L306 in this order to obtain the minimum distortion of RX Audio Output : when receiving a standard modulated signal at 0.5mV.
- (c) If there is more than half a turn difference in the settings of L304 and L306 in the adjustments steps a. and

b. above, a defective L304, L306 or the matching circuit is likely.

- c. Receiver First Local Oscillator Level : Local input level to Z2 is designed to be +7 dBm/50 ohms. Generally the Input level is ± 6 to +8 dBm. If local input level is 3 dBm or less, sensitivity, inter-modulation and IF/2 spurious will be degraded.
- d. If the receive sensitivity changes by more than 5 dB across the band (18 MHz) a circuit defect associated with FL301 and FL302 is likely.

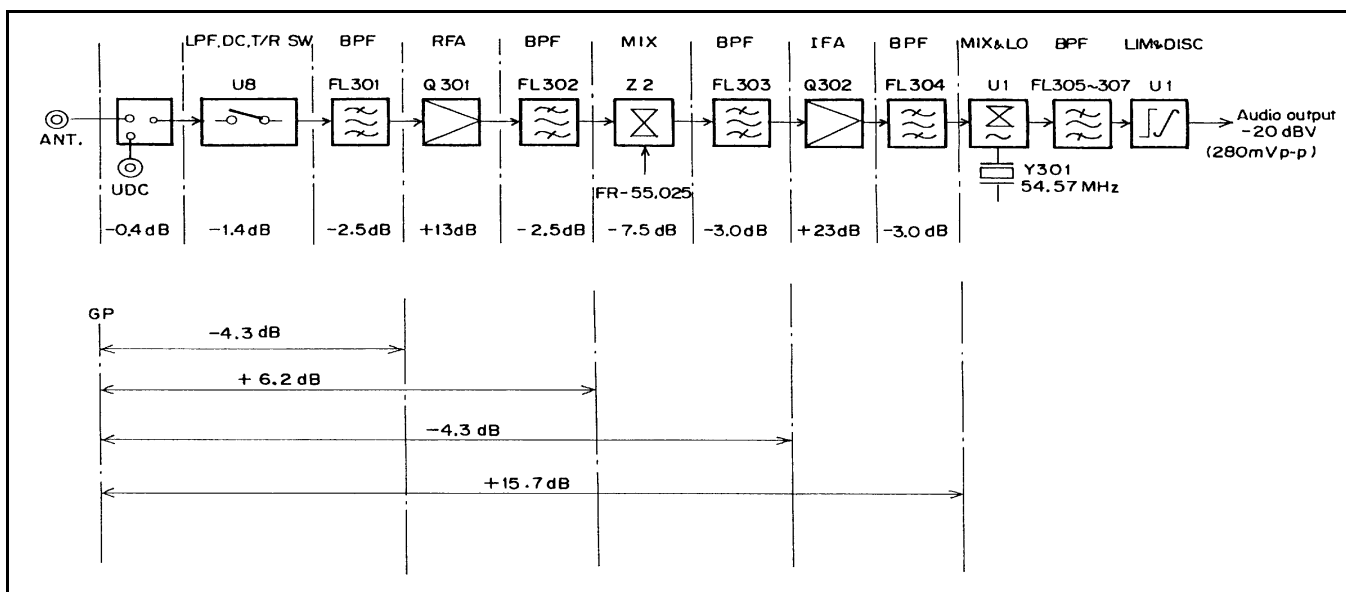

Figure 8 - Typical Level Diagram

Table 3 - Receive Section Typical Voltages

No.	Test Points	Voltage (V)	Remarks
1	Q301	1.5	
2	Q301	0.8	
3	Q301	5.8	
4	Q302	1.2	
5	Q302	0.4	
6	Q302	4.0	
7	U10 (1)	0 (GND)	
8	U10 (2)	7.4	
9	U10 (3)	5.0	
10	U11 (1) (13) (20)	0 (GND)	
11	U11 (2)	3.0	
12	U11 (3)	3.0	
13	U11 (4)	3.0	
14	U11 (5)	2.4	
15	U11 (6)	3.3	
16	U11 (7)	3.2	
17	U11 (8)	3.2	
18	U11 (9)	2.6	
19	U11 (10)	3.3	
20	U11 (11)	0.9	
21	U11 (12)	0.6	
22	U11 (14)	0.7	
23	U11 (15)	0.7	
24	U11 (16)	—	
25	U11 (17)	—	
26	U11 (18)	—	
27	U11 (19)	4.1	
28	U11 (21)	1.1	
29	U11 (22)	4.1	
30	U11 (23)	3.4	

No.	Test Points	Voltage (V)	Remarks
31	U11 (24)	3.9	
32	U12 (1)	0.9	
33	U12 (2)	0.9	
34	U12 (3)	0 (GND)	
35	U12 (4)	5.0	
36	U12 (5)	5.0	

4. If distortion in the received signal is substantially high, try to perform checks with the Radio and Control Board Individually.
 - a. Check the Local Oscillator Frequency. Check the frequency after connecting a frequency counter through a 1 PF capacitor to the collector of Q103. The frequency relation at various stages is shown In Figure 8. If a frequency error is 1.5 PPM or more In the temperature range of 20 to 25C, adjust the frequency of VCTCXO (Z1). The frequency of VCTCXO is 13.2 MHz.
 - b. Check the Usable Band Width. Usable band width is generally ± 2.5 kHz or more of the desired receiving frequency. If the \pm balance is greatly different, the received signal may be distorted. This time, the problem is probably caused by FL303, FL304, FL305, FL306, FL307 or its associated components.
 - c. Distortion Check : When the radio receives a standard modulated signal, the audio output at the Audio terminal J1-3B (P1-3B) is about 280mVp-p. At this point, the distortion will be about 3%. This is because the receiver discriminator output is connected to the RX Audio terminal and de-emphasis and BP Filtering has not, at this point, been provided. Because considerable noise is contained from low audio frequencies to high audio frequencies, use test equipment with a high input impedance (100K ohms) for the distortion measurement.
 - d. The signal from the Radio Board is applied to the Control Board at P1-3B and then to the speaker through U7 and U11. Check distortion at each point.

e. Even if there are no electrical problems with the audio circuits on the Control Board, the speaker itself may cause distortion mechanically. The voice coil may rub or the diaphragm may be damaged or touching another part of the radio.

5. Noise Squelch does not operate :

A part of receiver discriminator output is applied to the Control Board through J1-3B (P1-3B).

a. The operation of squelch is control led by Audio Processor U7 on the Control Board.

b. The squelch operation level is set in the channel data E2PROM. Refer to E²PROM Programming.

6. Other Problems and Cautions :

a. A polyimide flex circuit is used at the LCD/KB Flex Assy. If LCD/KB Flex Assy is repeatedly disassembled for maintenance, the flex circuit can be damaged. Accordingly, keep disassembly of the Control Unit at a minimum.

Transmit Circuit

The following flowchart can be used to isolate a defective stage in the transmit circuit. Also, refer to Table 4 - Typical Transmit Circuit Voltage.

Flowchart: (Shown at right)

Troubleshooting for the Transmit Circuit :

1. Troubleshooting the Antenna Switch : Antenna Switch P1 (and J2) is a mechanical switch used to switch the RF signal between the antenna and the UDC RF connector J1. Periodically it is necessary to check that the antenna, the UDC RF Connector and RF Test Adapter (Coaxial Connector) are tightened securely. If the Antenna Switch does not contact properly even through the antenna and connectors are tightened securely, the contact of Antenna Switch may be defective.

As prescribed in the preventive maintenance section of the applicable maintenance manual, periodically clean the contact of the Antenna Switch by blowing compressed air on it. Otherwise, dust and dirt will collect on the contact and result in contact failure.

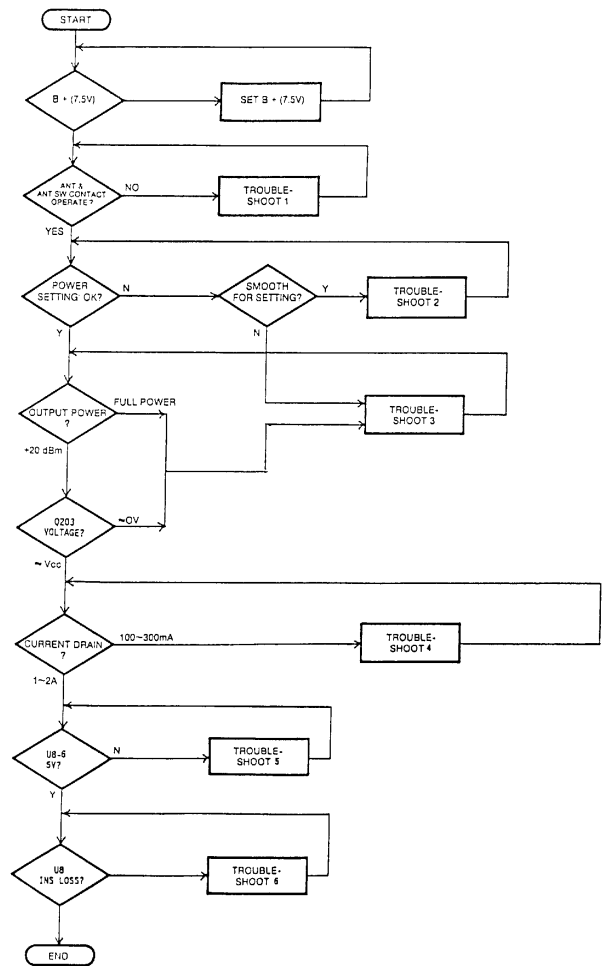

2. Check RF Output : If the transmit circuit can be set for the rated output, the transmit circuit is working properly.

Checking

1. When the rated power output cannot be obtained smoothly, check U8.
2. If the rated power output cannot be obtained, check transistor Q203.
3. Transistor Q203 Voltage Check : When the collector voltage of transistor Q203 is about 0 volts, Q203, Q204 or U9 is probably defective.
- 4 a. If the current drain of the battery is in range of 100 to 300 milliamperes, verify that the voltage on Pin 3 of U7 is 7.3 volts. If 7.3 volts is not present at this point, the problem is with the D-PTT line

(Q201, Q202). Check to see if there is an open- or a short- circuit on other lines on the Vcc line.

- b. If 7.3 volts is present at the above pins, check that voltage at collector of Q104 . If so, then check the output level of U5 (VCO-TO).
 - c. When the output of U5 is around 0 dBm, the problem is Q104. When the output level is -5 dBm or lower, the VCO in the synthesizer circuit is probably defective. Try the troubleshooting procedure for the Synthesizer to verify the trouble with the VCO.
5. Checking Voltage at U8 : Under normal conditions, the voltage at the Pin 6 of U8 is 5 volts. If 5 volts is not present at this point, refer to troubleshoot 4.
 6. Checking the U8 (LPF.DC.T/R SW) Insertion Loss : If an increase in the insertion loss of the U8 is suspected, the problem is U8.

Table 4 - Typical Transmit Voltages

No.	Test Points	Voltage (V)	Remarks
1	U7 (1)	—	
2	U7 (2)	0 (Rx), 3.7 (Tx)	Changed by power level
3	U7 (3)	0 (Rx), 7.3 (Tx)	
4	U7 (4)	7.4	
5	U7 (5)	—	
6	U7 (6)	0 (GND)	
7	U8 (2)	—	
8	U8 (4)	0 (Rx), 2.5 (Tx)	Changed by power level
9	U8 (6)	0 (Rx), 5.0 (Tx)	
10	U8 (8)	0 (Rx), 1.6 (Tx)	
11	U8 (13)	—	
12	U8 (1) (3) (5) (7) (9) (11) (12) (14)	0 (GND)	
13	Q104 Base	0 (Rx), 1.4 (Tx)	

No.	Test Points	Voltage (V)	Remarks
14	Q104 Emitter	0 (Rx), 0.8 (Tx)	
15	Q104 Collector	0 (Rx), 7.2 (Tx)	
16	Q201 (1)	7.5 (Rx), 0 (Tx)	
17	Q201 (2)	0 (Rx), 5.0 (Tx)	
18	Q201 (3)	5.0 (Rx), 0 (Tx)	
19	Q201 (4)	0 (Rx), 5.0 (Tx)	
20	Q201 (5)	0 (GND)	
21	Q201 (6)	0 (GND)	
22	Q202 (1)	7.5 (Rx), 0 (Tx)	
23	Q202 (2)	0 (Rx), 7.3 (Tx)	
24	Q202 (3)	7.4	
26	Q203 Base	7.5 (Rx), 6.8 (Tx)	
27	Q203 Emitter	7.4	
28	Q203 Collector	0 (Rx), 3.7 (Tx)	Changed by power level
29	Q204 Base	0 (Rx), 1.7 (Tx)	Changed by power level
30	Q204 Emitter	0 (Rx), 1.1 (Tx)	Changed by power level
31	Q204 Collector	7.5 (Rx), 6.8 (Tx)	Changed by power level
32	Q205 (1)	5.0	
33	Q205 (2)	5.0 (Rx), 0 (Tx)	
34	Q205 (3)	0 (Rx), 5.0 (Tx)	
35	U9 (5)	3.6 (Rx), 2.4 (Tx)	Changed by power level
36	U9 (6)	0 (Rx), 2.4 (Tx)	Changed by power level
37	U9 (7)	0 (Rx), 1.7 (Tx)	Changed by power level
38	U9 (8)	0 (Rx), 4.9 (Tx)	
39	U9 (2) (3) (4)	0 (GND)	

PHASE 2 : LOGIC SECTION TROUBLESHOOTING

Flowchart (Internal Display and Switch Action)

Major Troubleshooting : (Display and Switch Action) can be used to isolate any defective stage located on the Control and the LCD/KB Flex Assy.

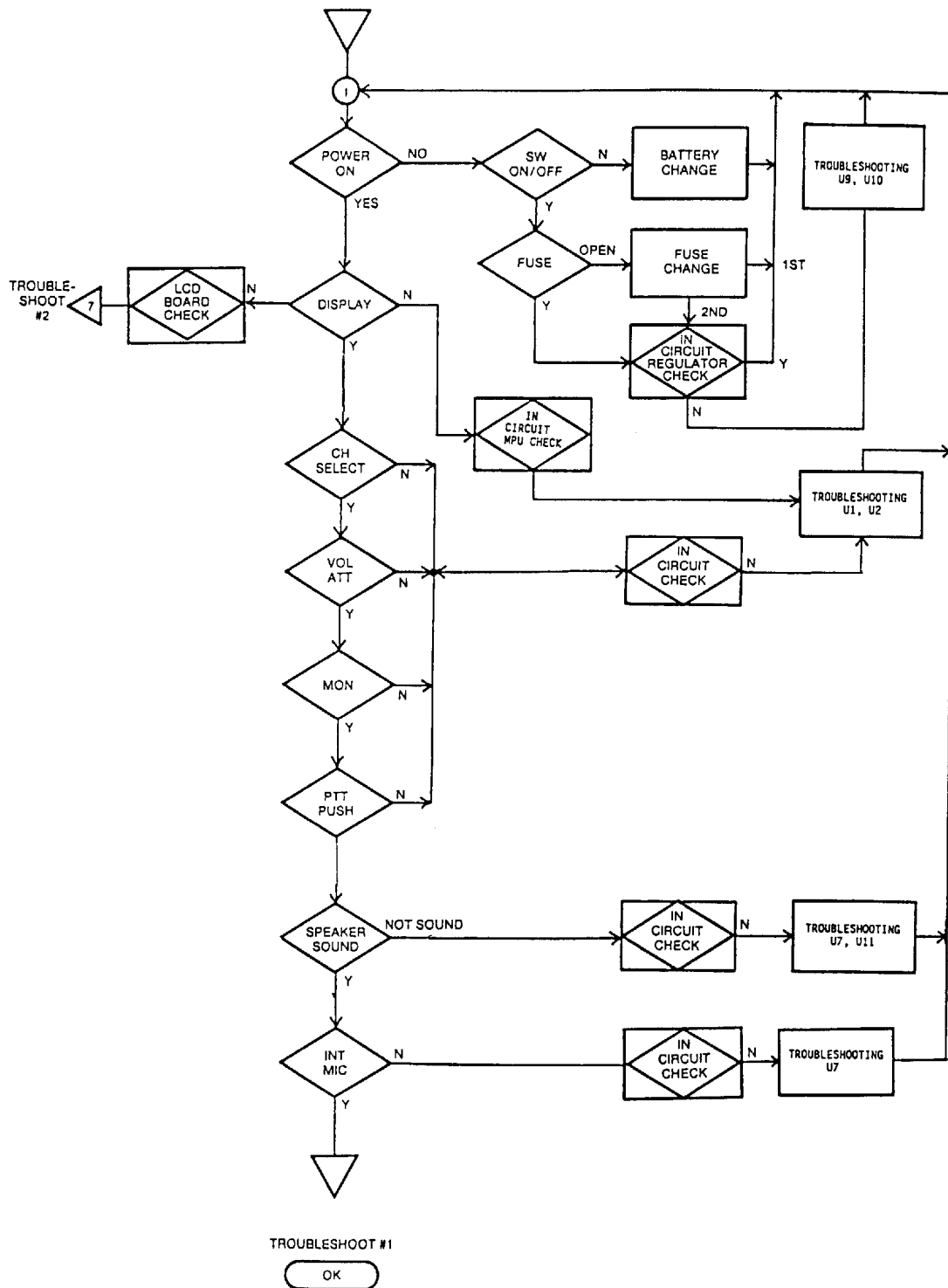

Functional Troubleshooting : (External Input and Output Action)

The flowchart (External Input and Output Action) can be used to externally function test the Control Board through the UDC.

LCD/KB Flex Assy : The flowchart (LCD/KB Flex Assy) can be used to isolate any defective stage located on the LCD/KB Flex Assy.

Flowchart (LCD/KB Flex Assy)

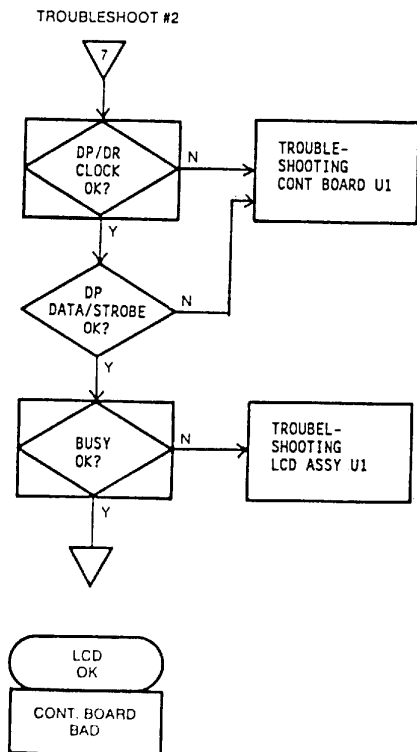

Troubleshooting for Logic Section

1. This troubleshooting should be made with the Control Board isolated from the Radio Board.
2. If the result is OK at Step 1, the E²PROM data (Channel No.) is displayed when power is ON. In the unlocked state of the Phase-Lock-Loop (PLL) UN-LOCK display is turned on and off at PTT.
3. If the result is OK at Step 2, the display should flicker in the unlocked state.
4. Step 3 indicated that the various switches are actuated in the sequence determined with the E²PROM data.
5. At Step 4, with 1 kHz, -20 dBV signal applied to RX, DISC terminal, check for 0.5 watt/16 ohm output to be present at the AUDIO OUT terminal.

It should also be noted that when the initial VOL ATT setting is not at 0.5 watt/16 ohm, operate the AF, VOL (R8) for a volume level of 0.5 watt.

6. At Step 5, when the PTT line is grounded, the radio set is switched to the TRANSMIT mode. Then the PTT button on the side of the radio should be released.

When the transmit mode is verified, apply 1 kHz, -40 dBV signal to the EXT MIC terminal from the Audio Analyzer. Check that a -7dBV +2 dB signal appears at the TX AUDIO terminal (Pin 2B of P1). Take note that the output at TX AUDIO is not subjected to limiting and without Channel Guard.

7. At Step 6, generate an arbitrary radio data with a data loader and try to load the data in the E²PROM. Check that data is loaded properly.
8. To perform an internal microphone (INT MIC) test, press and hold the PTT button and speak into the internal microphone. Check that an audio signal appears at Pin 2B of P1 (TX AUDIO terminal).

Flowchart : (External Input and Output Action)

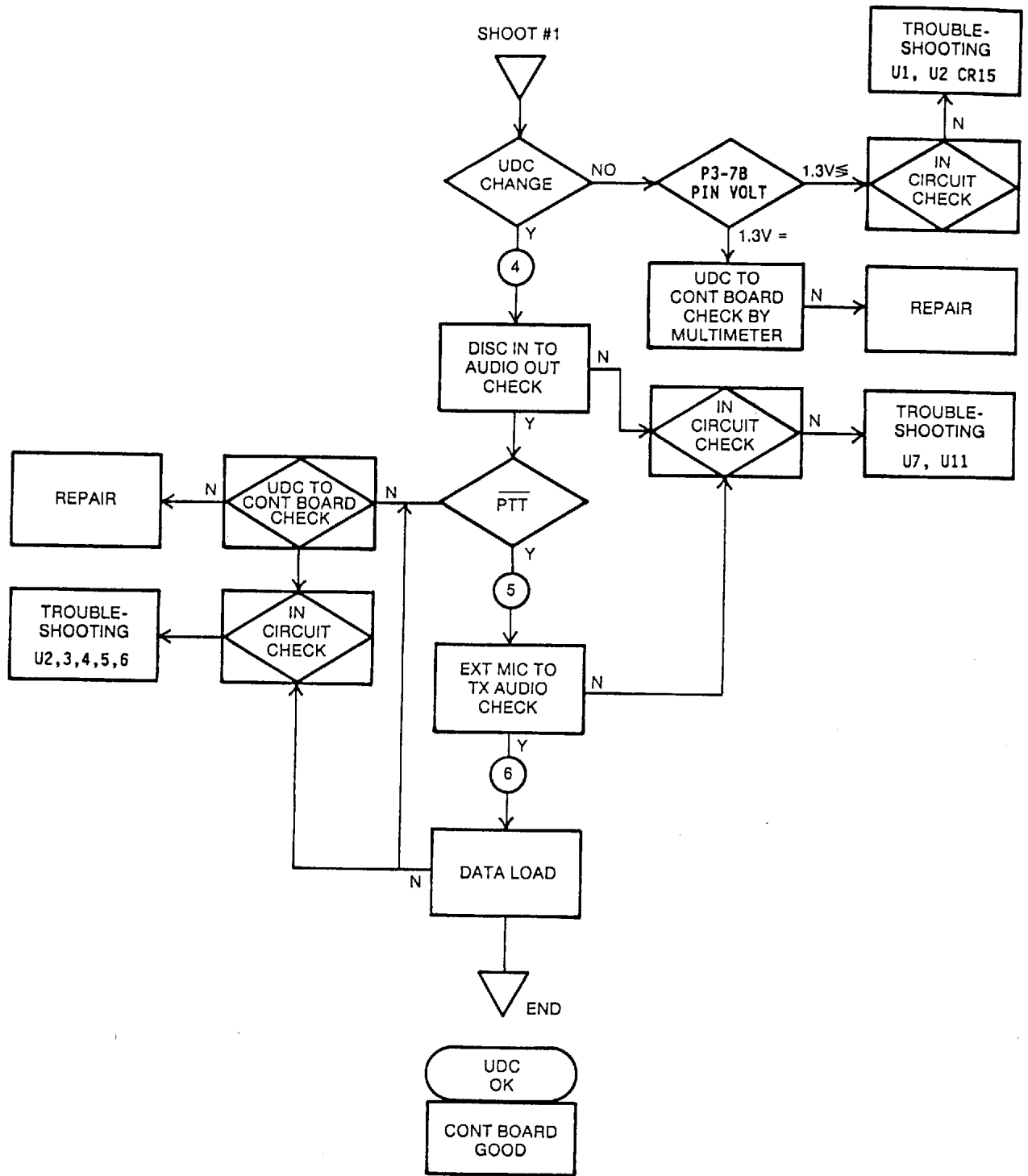

Logic Section Check List :

		MEASURING INSTRUMENT						
		Digital Voltmeter DC Power Supply Frequency Counter						
ITEM	TEST PROCEDURE							
1. Preliminary 1-1 Voltage Check	There are two regulated supply lines. Conduct voltage check at each check point as under. <table border="1" style="margin-left: auto; margin-right: auto;"> <thead> <tr> <th>Check Point</th> <th>Rated Voltage</th> </tr> </thead> <tbody> <tr> <td>U9 - Pin 1</td> <td>5.0 V \pm0.2 V for Control</td> </tr> <tr> <td>U10 - Pin 3</td> <td>5.0 V \pm0.2 V for Audio</td> </tr> </tbody> </table>		Check Point	Rated Voltage	U9 - Pin 1	5.0 V \pm 0.2 V for Control	U10 - Pin 3	5.0 V \pm 0.2 V for Audio
Check Point	Rated Voltage							
U9 - Pin 1	5.0 V \pm 0.2 V for Control							
U10 - Pin 3	5.0 V \pm 0.2 V for Audio							
1-2 Battery Out Check	Check that the voltage of Battery or DC Power Supply is present at P1-1B, P2-14B and P2-15b.							
1-3 Oscillator Frequency Check	Check Crystal "Y1" (IC U2-Pin 69) with frequency counter. The frequency should be within 9.8304 MHz \pm 300 Hz. Check Crystal							

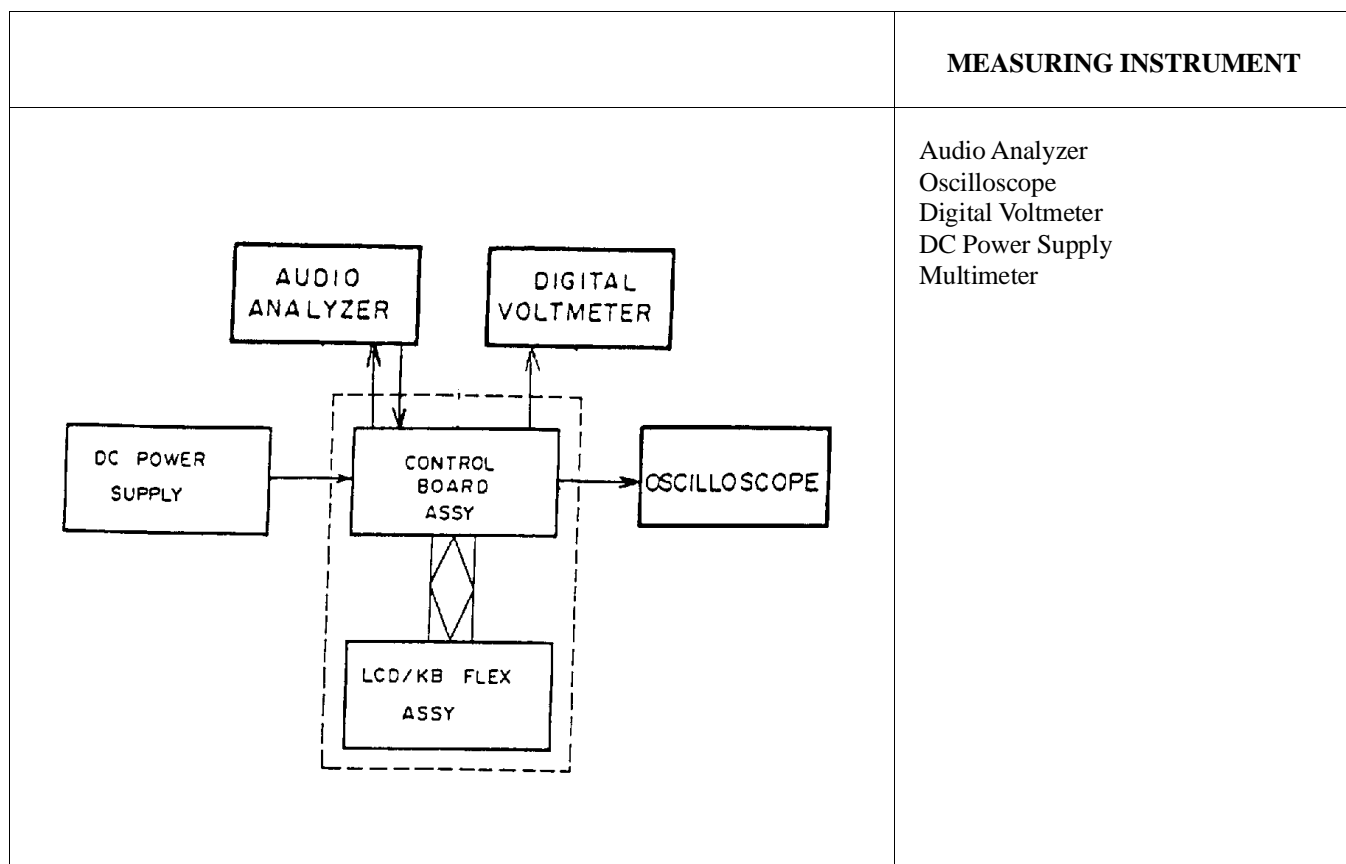

ITEM	TEST PROCEDURE	
2. Preliminary 2-1 LCD/KB FLEX	1. Check LCD/KB FLEX by turning power supply on. Insert connector (J1) on LCD/KB FLEX into P2 on Control Board. Then turn power on and check that the data from Control Board is displayed in the LCB/KB FLEX.	
3. SW Check and UDC Check	2-a. Operation for each switch, check whether each SW is operated or not by multimeter. Check List	
	SW-Name	Connector Pin No. to be checked
	AF. VOL PTT MON OPT EMR	<div style="border-left: 1px solid black; border-right: 1px solid black; padding: 5px; display: inline-block;"> 4B 1A 11A/13B 12A/13B 12B/13B </div> J1 —
		LCD/KB Flex Assy.

ITEM	TEST PROCEDURE																								
	<p>2-b UDC Check.</p> <p>Check List</p> <div style="display: flex; justify-content: space-around; align-items: center;"> <div style="border: 1px solid black; padding: 10px; text-align: center;"> <p>Pin No. to be checked</p> <table style="margin: auto;"> <tr><td style="border-right: 1px solid black; padding: 2px 10px;">1A</td><td style="padding: 2px 10px;">- E3</td></tr> <tr><td style="border-right: 1px solid black; padding: 2px 10px;">1B</td><td style="padding: 2px 10px;">- E2</td></tr> <tr><td style="border-right: 1px solid black; padding: 2px 10px;">2A</td><td style="padding: 2px 10px;">- E1</td></tr> <tr><td style="border-right: 1px solid black; padding: 2px 10px;">2B</td><td style="padding: 2px 10px;">- E6</td></tr> <tr><td style="border-right: 1px solid black; padding: 2px 10px;">3B</td><td style="padding: 2px 10px;">- E4</td></tr> <tr><td style="border-right: 1px solid black; padding: 2px 10px;">4B</td><td style="padding: 2px 10px;">- E5</td></tr> <tr><td style="border-right: 1px solid black; padding: 2px 10px;">5B</td><td style="padding: 2px 10px;">- E7</td></tr> <tr><td style="border-right: 1px solid black; padding: 2px 10px;">6B</td><td style="padding: 2px 10px;">- E10</td></tr> <tr><td style="border-right: 1px solid black; padding: 2px 10px;">7A</td><td style="padding: 2px 10px;">- E12</td></tr> <tr><td style="border-right: 1px solid black; padding: 2px 10px;">7B</td><td style="padding: 2px 10px;">- E8</td></tr> <tr><td style="border-right: 1px solid black; padding: 2px 10px;">8A</td><td style="padding: 2px 10px;">- E11</td></tr> <tr><td style="border-right: 1px solid black; padding: 2px 10px;">8B</td><td style="padding: 2px 10px;">- E9</td></tr> </table> </div> <div style="text-align: center;"> <p>UDC Flex</p> </div> <div style="text-align: center;"> <p>UDC SIDE VIEW</p> </div> </div>	1A	- E3	1B	- E2	2A	- E1	2B	- E6	3B	- E4	4B	- E5	5B	- E7	6B	- E10	7A	- E12	7B	- E8	8A	- E11	8B	- E9
1A	- E3																								
1B	- E2																								
2A	- E1																								
2B	- E6																								
3B	- E4																								
4B	- E5																								
5B	- E7																								
6B	- E10																								
7A	- E12																								
7B	- E8																								
8A	- E11																								
8B	- E9																								
<p>4. RX S/N Measurement</p>	<p>Set Audio Analyzer for 1 kHz, -20 dBv output. Apply this 1 kHz signal to RX AUDIO IN P1 Pin 3B. Turn AF. VOL> to get Maximum output and check that the level at RX AUDIO OUT of P3 PIN 8B (-10 dBv or more) on Oscilloscope.</p> <p>Adjust CAL control on AUDIO Analyzer for "0". Turn 1 kHz signal off. Check that noise level is -45 dB or less.</p>																								
<p>5. RX Frequency Response</p>	<p>Set Audio Analyzer for 1 kHz, -30 dBv output. Apply this 1 kHz signal to RX AUDIO IN P1 PIN 3B. Check that the level at RX AUDIO OUT of P3 PIN 3B is -20 dBv on Levelmeter and Oscilloscope. Adjust CAL control on Audio Analyzer for "0" to turn 1 kHz signal off. Change the OSC frequency from 210 Hz, 270 Hz, 300 Hz and 310 Hz to 10 kHz. Plot AUDIO OUT level on a graph. Check that the level from 300 Hz to 3 kHz is in the range of +1 dB to -3 dB from octave.</p>																								

ITEM	TEST PROCEDURE
6. RX Audio Distortion Measurement	<p>Set Audio Analyzer for 1 kHz. Apply this 1 kHz signal to RX AUDIO IN P1 PIN 3B. Adjust until Levelmeter and Oscilloscope show that the P3 PIN 8B is -10 dBV.</p> <p>Check that Audio Analyzer distortion meter shows 5% or less at this time.</p> <p>Alternatively it is permitted to use SPEAKER AUDIO OUT as the check point.</p>
7. CG Opening Level Measurement	<p>Set Audio Analyzer for 67 Hz to 210.7 Hz. Apply this 67 Hz signal to RX AUDIO IN P1 PIN 3B. Decrease the level of Audio Analyzer until the squelch opens. Check that the opening level is about -38dBV.</p> <p>NOTE : Use the channel with CG tone in this test.</p>
8. SQ Operation	<p>Set Audio Analyzer for 10 kHz. Apply this 10 kHz signal to RX AUDIO IN P1 PIN 3B.</p> <p>Check the output voltage for U2 Pin 59 on Control Board and plot the level on a graph. It is permitted that only the opening level and the closing level of squelch are checked.</p>
9. TX S/N Measurement	<p>On Test Set, set PTT switch to PTT and check that the Unit goes into transmit mode. Set Audio Analyzer to 1 kHz -40dBV. Apply this 1 kHz signal to EXT MIC Terminal of Test Set. There should be about -7 dBV signal at TX AUDIO OUT at P1 PIN 2B. Adjust CAL control on Analyzer to null. Then turn the Analyzer output off. The S/N ratio should be 40 dB or better.</p>
10. TX Distortion Measurement	<p>Under the same test condition as with S/N measurement, measure distortion with the Audio Analyzer. The distortion should be less than 3%.</p>
11. TX Frequency Response	<p>Set Audio Analyzer for 1 kHz, -50 dBV. Apply this 1 kHz signal to EXT MIC Terminal of Test Set. Check that -17dBV signal is present at TX AUDIO OUT at P1 2B. Adjust CAL control on Audio Analyzer for null indication. Turn off the 1 kHz signal from Analyzer. Then change the output frequency of OSC 210 kHz, 260 Hz, 300 Hz to 2.9 kHz and 2.9 kHz to 10 kHz. Plot the changes in the output signal level on a graph. Check that the frequency response curve is within +1, -3 dB over a 300 to 3000 Hz range.</p>
12. Measurement of CG Encode	<p>Set PTT Switch to OFF on Test Set. Select that Level and Distortion channel for which SIG appears on the LCD. Change PTT Switch to PTT side. Check that either 67 Hz to 210.7 Hz CG waveform is present at TX AUDIO OUT using an oscilloscope. Measure the CG signal level (-19 dBV is reference level). Check that the distortion in the CG waveform is less than 5%.</p>
13. Power Set Action	<p>With the PTT Switch in the PTT Position, check with digital voltmeter that 2.0 to 4.0 V is present at PIN 2A of P1.</p>
14. Syn. Clock, Syn. Data, Syn. Enable and Syn. Wide/Narrow Output	<p>Using an Oscilloscope, check that Enable signal is present at PIN 7B of P1, Data at PIN 8A, Clock at PIN 8B and Wide/Narrow at PIN 6A. In this test LOCK/UNLOCK Switch should be in the UNLOCK position.</p>

M-RK LOGIC SECTION TEST DATA

TEST DATA
 TEST CONDITION TEMP C
 HUMIDITY %
 TEST ASSY CONTROL BOARD
 LCD/KB FLEX

NO.	TEST ITEM	STANDARD VALUE	TEST VALUE
1-1	REGULATORS	5.0 V \pm 0.2V	V
1-2	BATTERY OUT	7.5 V	V
1-3	OSCILLATORS	9.8304 MHz \pm 300 kHz	MHz
2-1	LCD CHECK	GOOD/NG	
3	SWITCH CHECK	GOOD/NG	
3	UDC CHECK	GOOD/NG	
	DATA LOAD	LOAD OK/NG	
4	RX SIG/NOISE	45 dB	dB
5	RX FREQ RESPONSE	0.3 K - 3 kHz +1 dB -3dB	
6	RX DISTORTION	< 5%	%
7	RX CG OPENING LEVEL	TYPICAL : -38dBv	dBV
8	SQ OPERATION	GOOD/NG	
9	TX SIG/NOISE	40 dB	dB
10	TX DISTORTION	< 3%	%
11	TX FREQ RESPONSE	0.3 K - 3 kHz + 1 dB -3dB	
12	TX CG ENCODE LEVEL	TYPICAL : -19 dBV	dBV
12	TX CG DISTORTION	< 5%	%
13	POWER SET	2.0 V - 4.0V	V
14	SYN WIDE/NARROW CLOCK DATA ENABLE OUT	GOOD/NG	

TRACKING DATA

Tracking data is information stored in radio personality E²PROM that sets various transmit parameters to ensure proper performance over the band. If the RF Board in the radio is replaced, this tracking data may need to be changed.

If tracking data is supplied with the replacement RF Board, use the radio personality programmer to edit the personality E²PROM and enter the new tracking data. If tracking data was not supplied with the RF Board, retain the original data stored in E²PROM.

MAINTAINING WEATHERPROOF INTEGRITY

The following maintenance procedure is required in order to assure that the radio housing will continue to meet the weatherproof features as designed.

1. Replace key pads which become damaged or torn.
2. Check the "O" ring at base of the antenna when the antenna is removed. Check the housing seal around flanges of the Rear Assy. when the radio unit is opened. Avoid pinching or abrading seals when assembling. Use a light coating of Silicone Grease (GE #623 Clear Silicone Protector, or equivalent) on sealing surfaces of "O" rings to provide lubrication and to increase surface tension for waterproofing.

NOTE

The antenna must be assembled securely to the top of the radio. Tighten to within two (2) to three (3) inch-pounds torque (40 in-ounces).



Ericsson GE Mobile Communications Inc.
Mountain View Road • Lynchburg, Virginia 24502

LCD / KB FLEX BOARD
 MICRO PROCESSOR (U1)

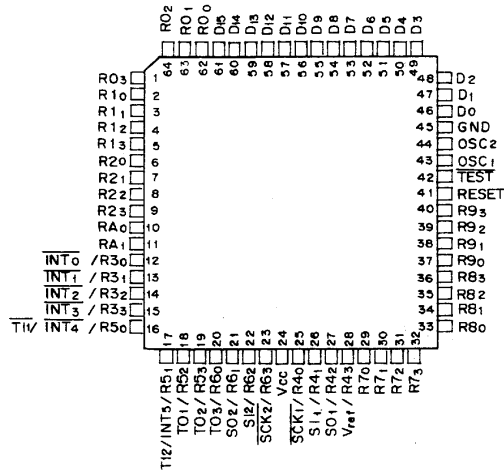

(TOP VIEW)

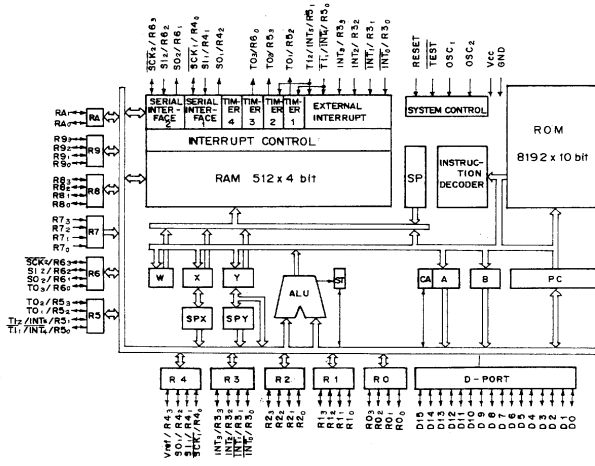

BLOCK DIAGRAM

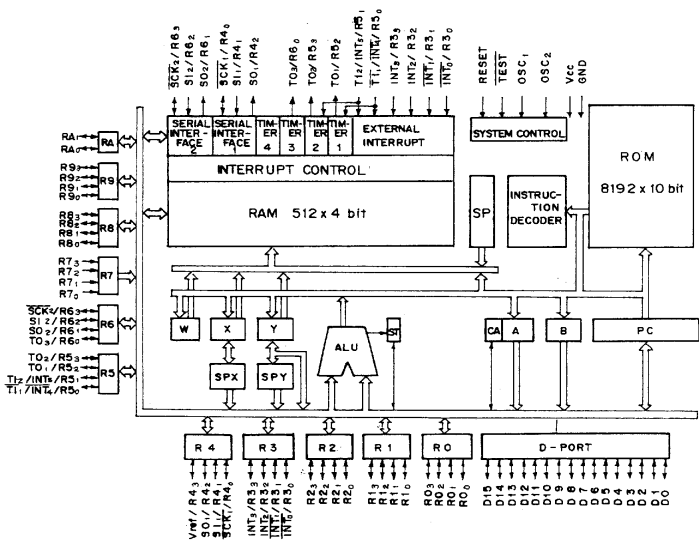

BLOCK DIAGRAM

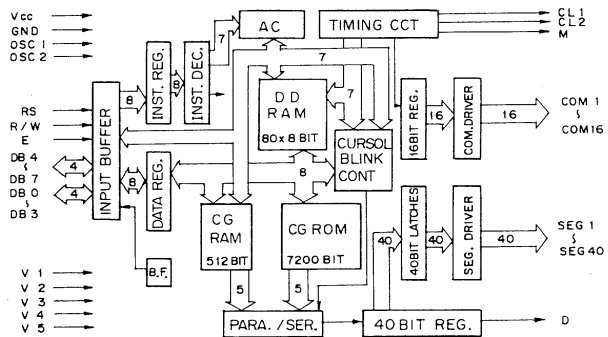

BLOCK DIAGRAM

LCD / KB FLEX
LED FLEX

AF VOLUME W / SWITCH
(R8)

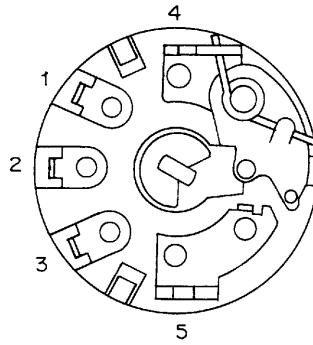

ROTARY SWITCH
(S1)

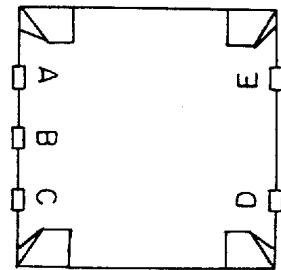

SPEAKER
(LS1)

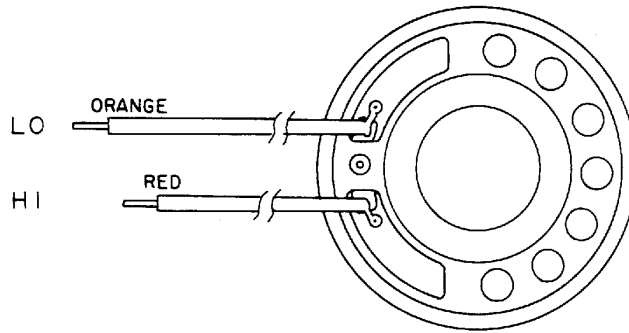

MICROPHONE
(MK1)

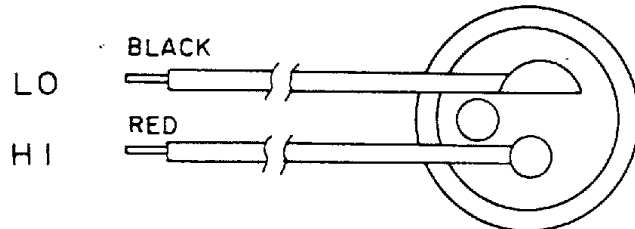

CONTROL BOARD
MICRO PROCESSOR (U1)

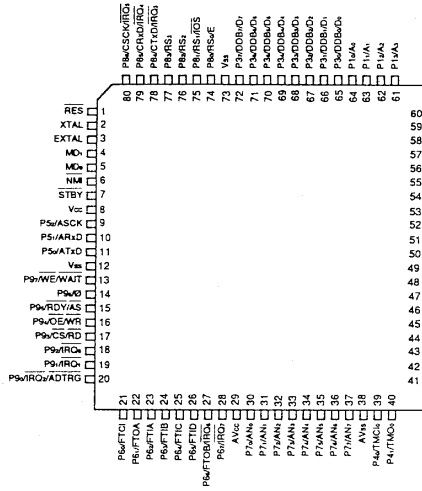

(TOP VIEW)

CONTROL BOARD
MICRO PROCESSOR (U2)

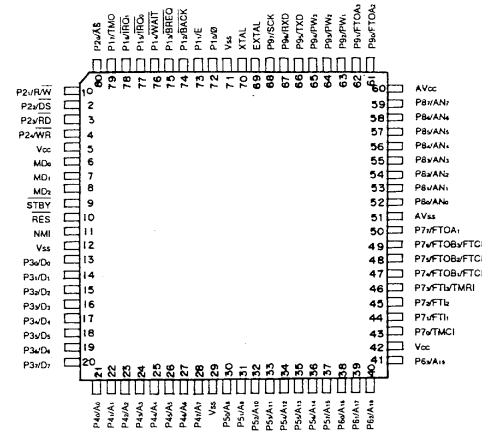

(TOP VIEW)

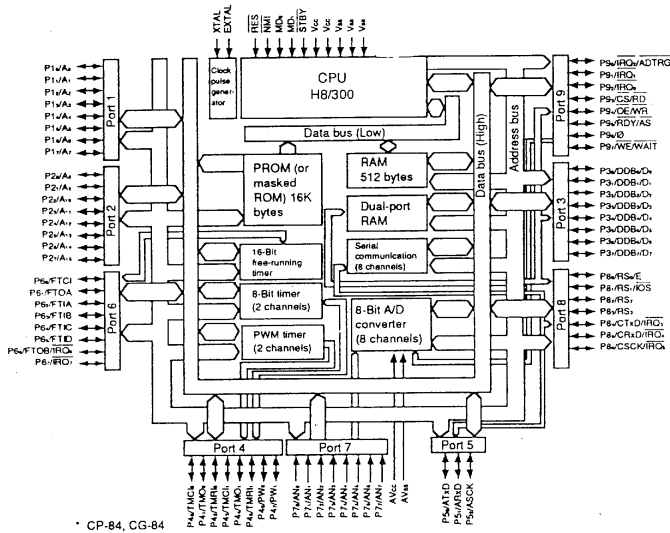

CP-84, CG-84

BLOCK DIAGRAM

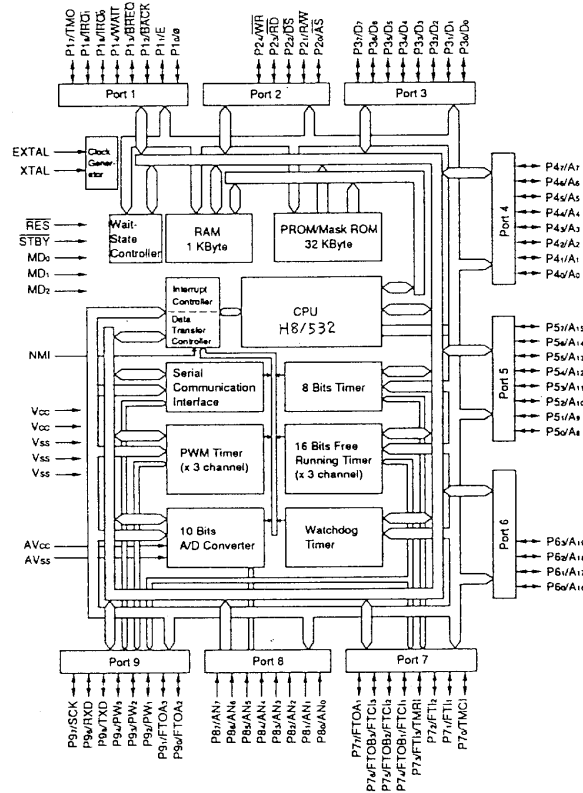

CONTROL BOARD
DIGITAL SIGNAL PROCESSOR (U3)

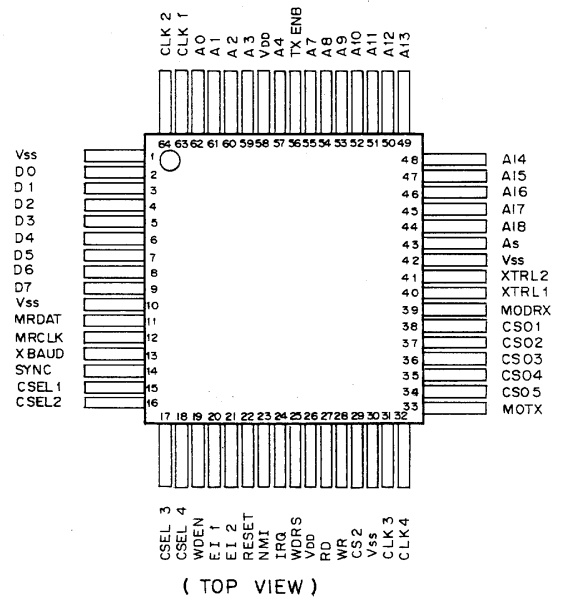
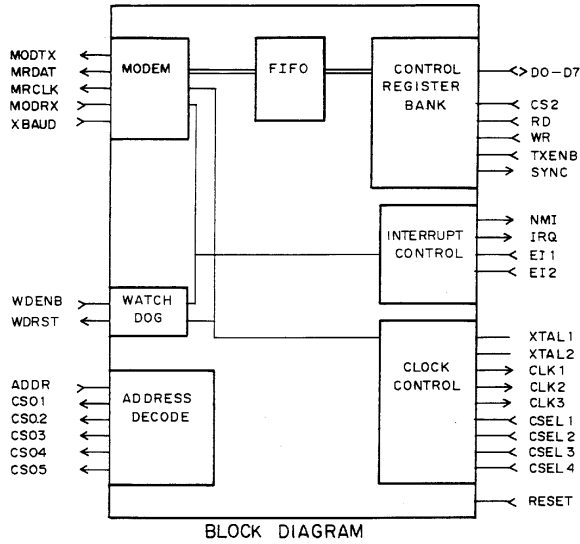

CONTROL BOARD
FLASH E²PROM (U4)

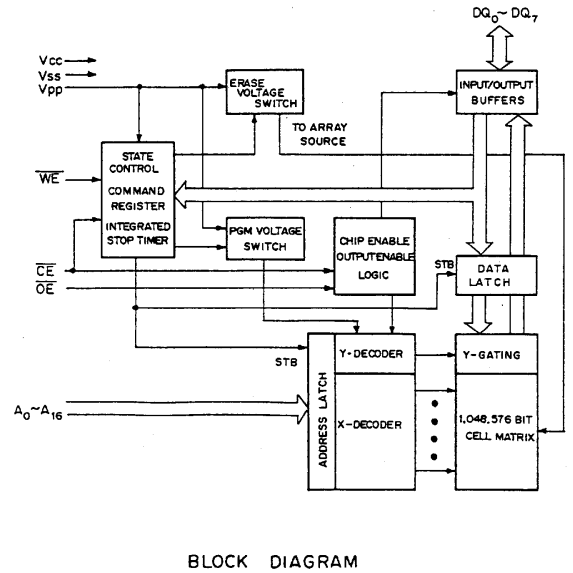
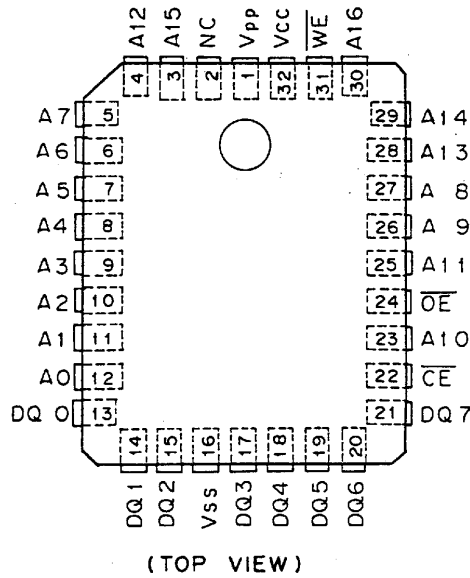

CONTROL BOARD
CMOS SRAM (U5)

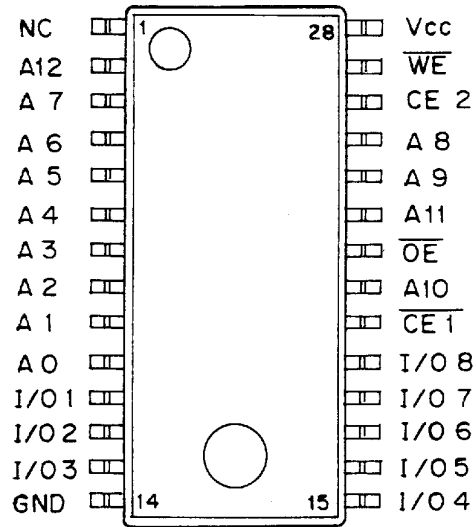

(TOP VIEW)

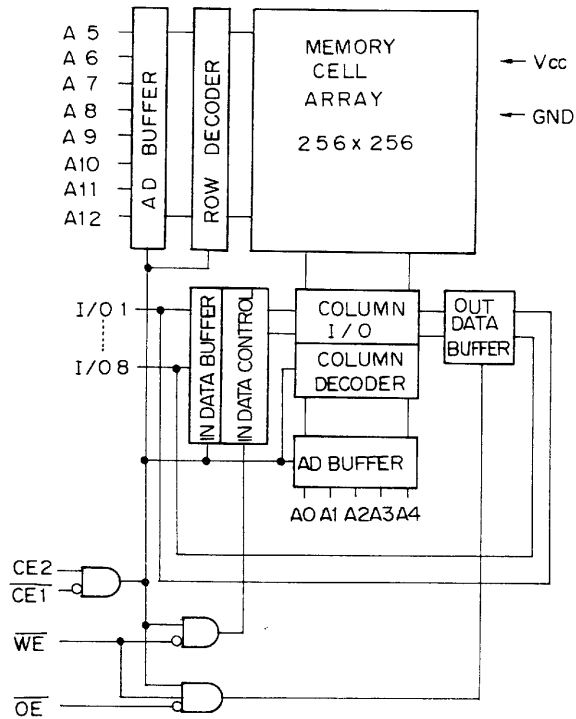

BLOCK DIAGRAM

CONTROL BOARD
AUDIO PROCESSOR (U7)

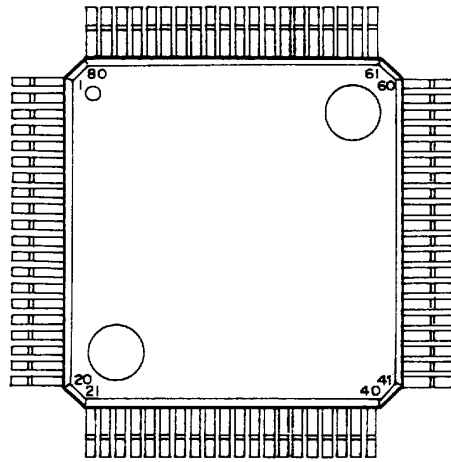

No	IO	name	No	IO	name	No	IO	name	No	IO	name
1	-	NC	21	O	LDSC	41	G	AGR	61	-	NC
2	I	OPU	22	O	LCGO	42	AO	MUX1	62	G	AGT
3	G	DG	23	O	CMPO	43	AO	R10	63	AO	TVD2
4	I	OSCI	24	-	NC	44	AI	RAFI	64	AO	TREF
5	O	OSCO	25	I	TSEL	45	AO	HP10	65	AO	BIAS
6	IO	CKIO	26	VD	VDD	46	AI	VRP	66	AO	BREF
7	G	DG	27	AO	RXAF	47	AO	DA	67	AO	LIM H
8	VD	VDD	28	AI	VGAF	48	AO	DAO	68	AO	LIM L
9	I	XRST	29	AI	DTMF	49	AI	ADIN	69	AO	LIMO
10	I	EN	30	AI	ALIN	50	AI	DISC	70	AO	TONE
11	I	STB	31	AI	NR1	51	IO	TREC	71	-	NC
12	I	DATA	32	AI	PR1	52	AO	NSQ	72	AO	VG AU
13	O	SW5	33	-	NC	53	AO	OS 1	73	AI	EMIC
14	O	SW4	34	AI	NC 1	54	AI	NS 1	74	AI	IMIC
15	O	SW3	35	AI	PC 1	55	AI	PS 1	75	AI	TTON
16	O	SW2	36	AO	A	56	-	NC	76	AO	ALER
17	O	SW1	37	AO	CGO	57	AI	TIN	77	VD	VDD
18	O	SW0	38	AI	TOIN	58	AI	CGIN	78	I	VG
19	VD	VDD	39	AO	RREF	59	AI	DTIN	79	I	EDAT
20	G	DG	40	AO	RVD2	60	AO	TXAU	80	I	IDAT

(TOP VIEW)

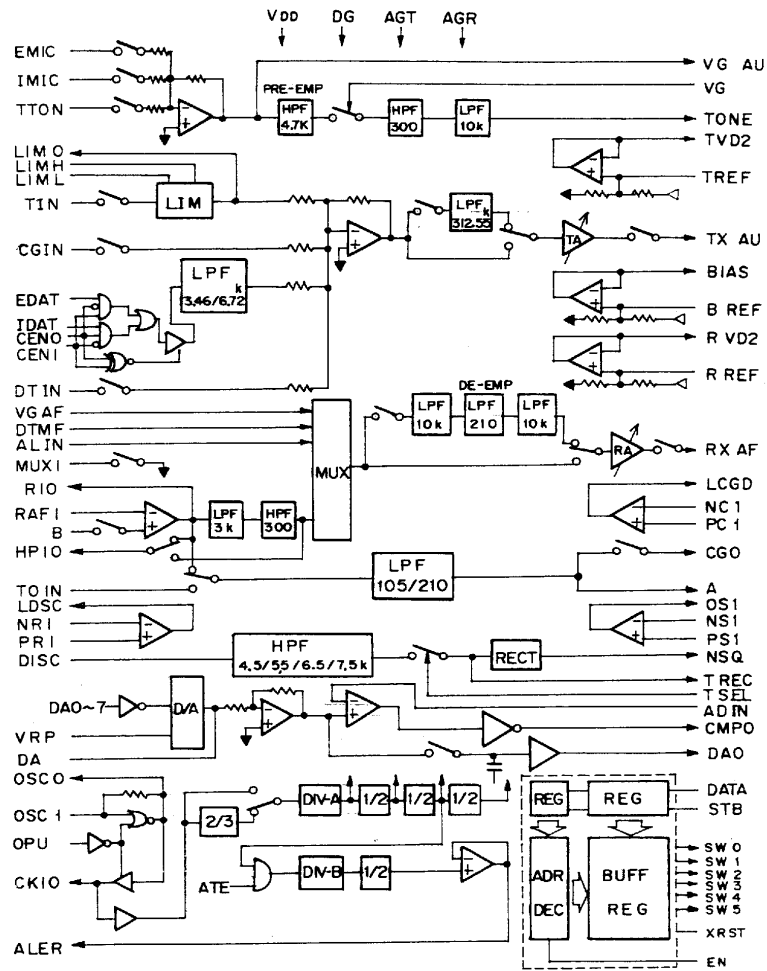

BLOCK DIAGRAM

CONTROL BOARD
VOLTAGE REGULATOR (U9)

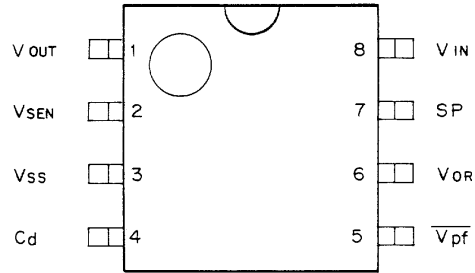

(TOP VIEW)

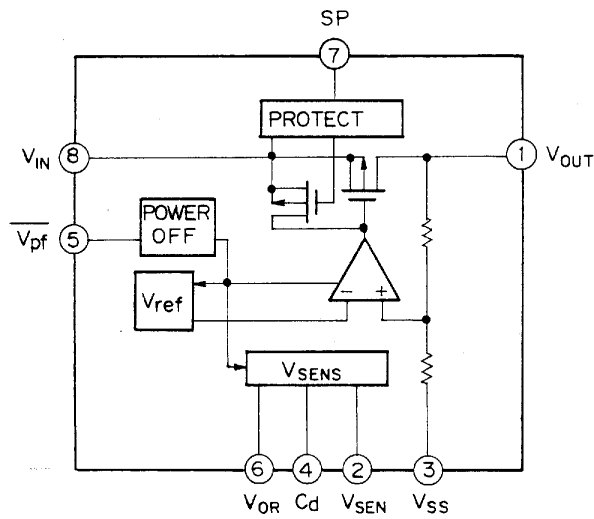

CONTROL / RF BOARD
VOLTAGE REGULATOR (U10)

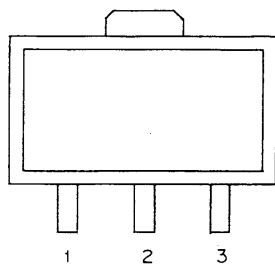

(TOP VIEW)

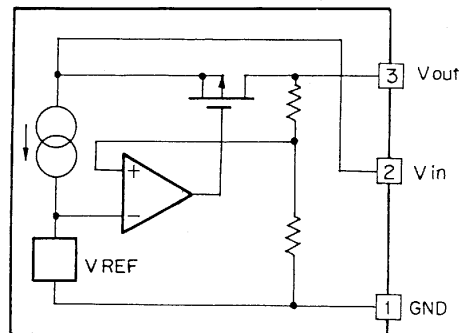

CONTROL BOARD
 INTEGRATED CIRCUIT/AF POWER AMPLIFIER (U11)

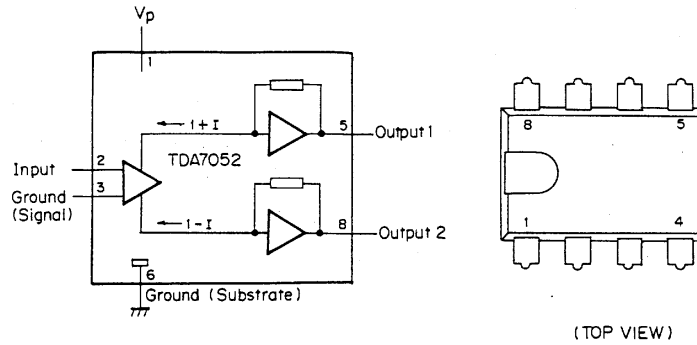

BLOCK DIAGRAM

(TOP VIEW)

CONTROL BOARD
 E² PROM (U6)

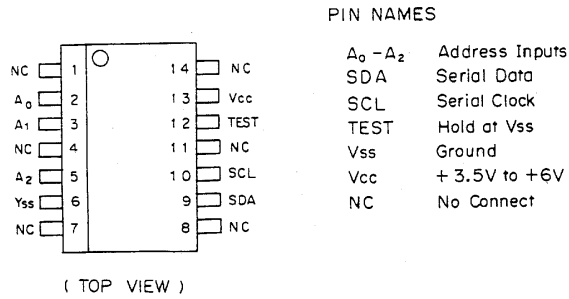

PIN NAMES

(TOP VIEW)

CONTROL BOARD
 2 INPUT OR GATE (U15)

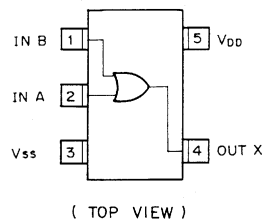

(TOP VIEW)

CONTROL BOARD
 3 INVERTERS (U12)

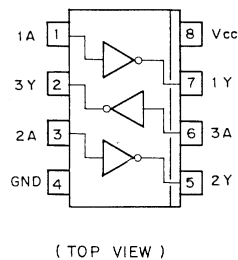

(TOP VIEW)

CONTROL BOARD
SERIAL NUMBER (U16)

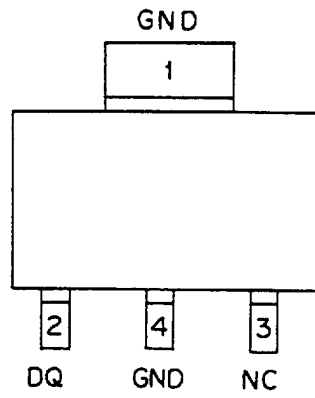

(TOP VIEW)

RF BOARD
BAND PASS FILTER (FL201)

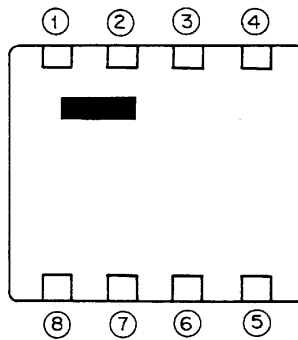

(TOP VIEW)

- ① INPUT
- ② GND
- ③ GND
- ④ OUTPUT
- ⑤ NC 1
- ⑥ GND
- ⑦ GND
- ⑧ NC 1

RF BOARD

BAND PASS FILTER (FL301, FL302)

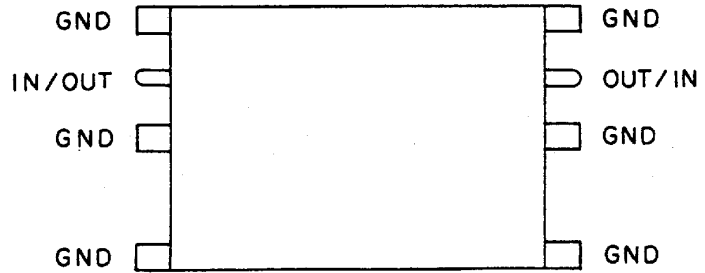

VHF (TOP VIEW)

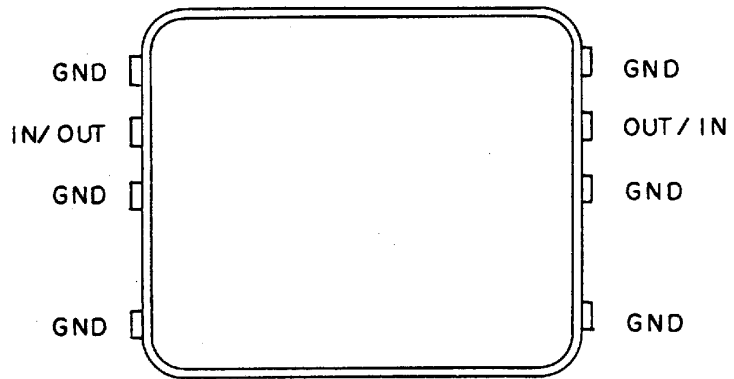

UHF (TOP VIEW)

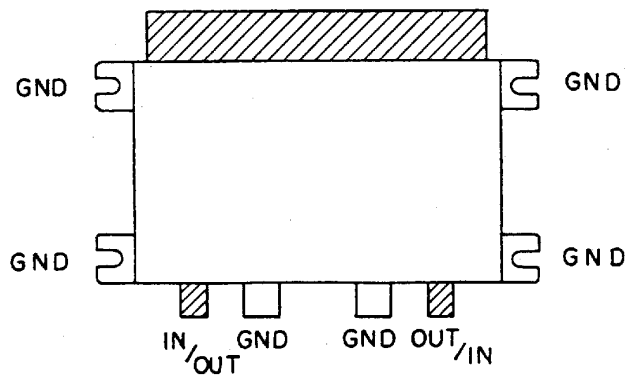

800/900 MHz (TOP VIEW)

RF BOARD
BAND PASS FILTER (FL305, FL306, FL307)

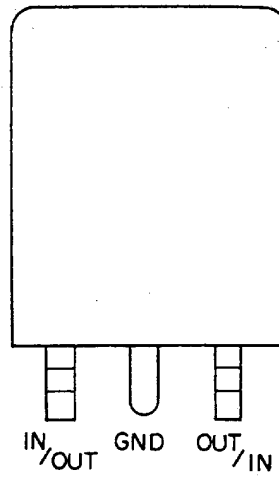

(TOP VIEW)

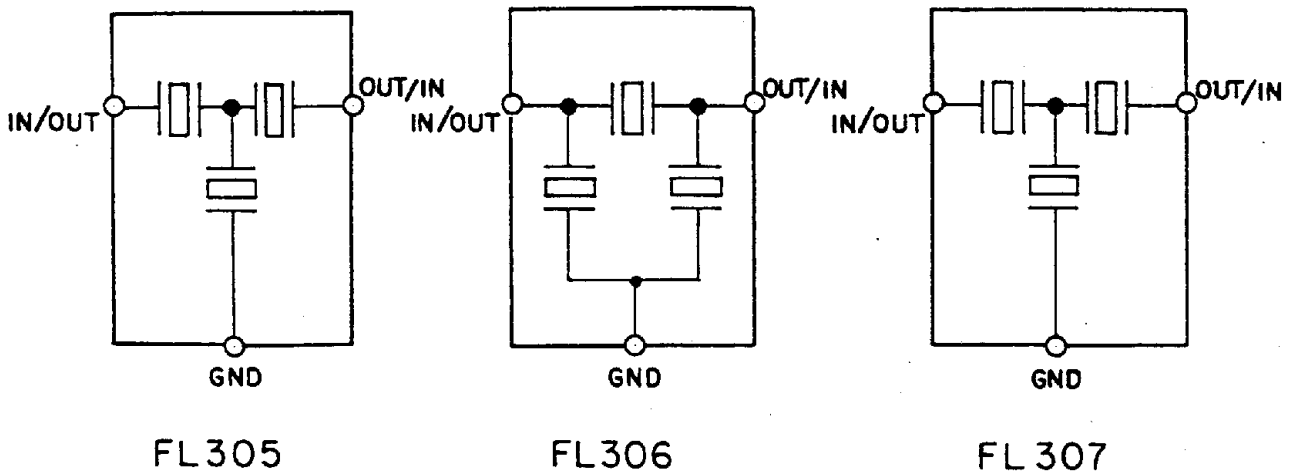

RF BOARD
PRESCALER (U1)

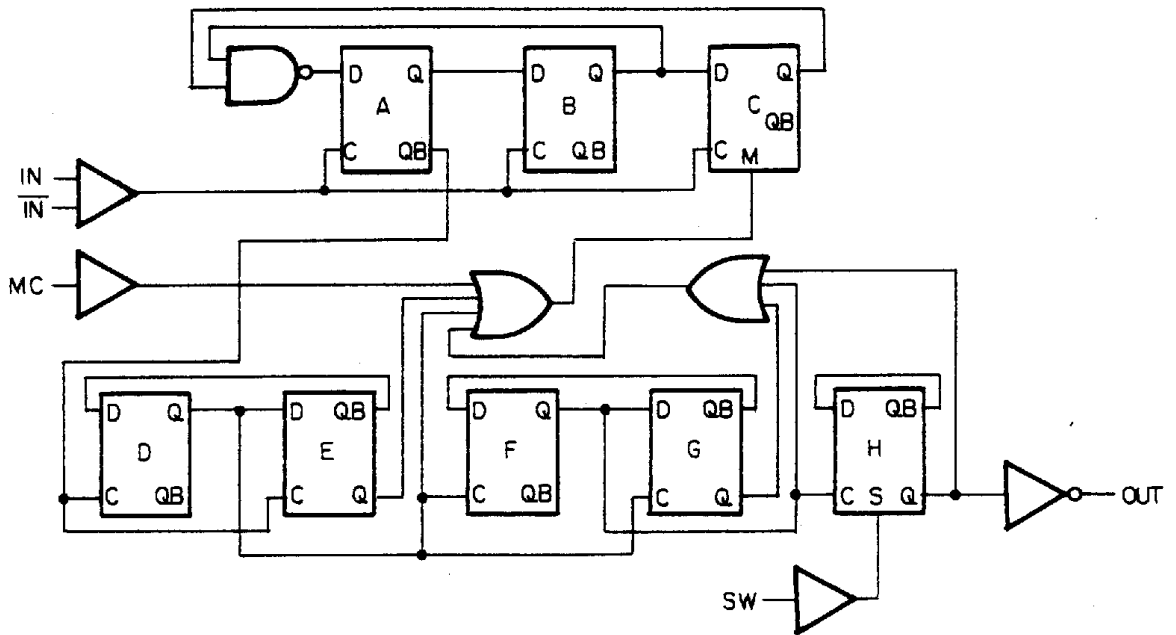
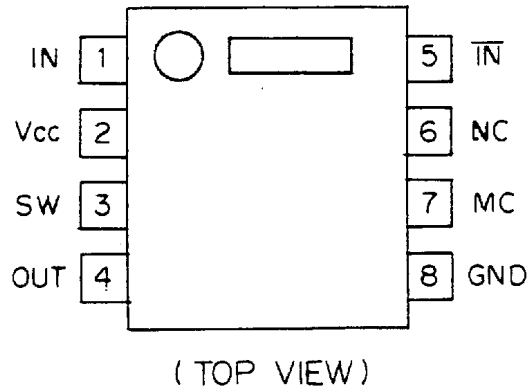

BLOCK DIAGRAM

RF BOARD
PHASE LOCK LOOP (U2)

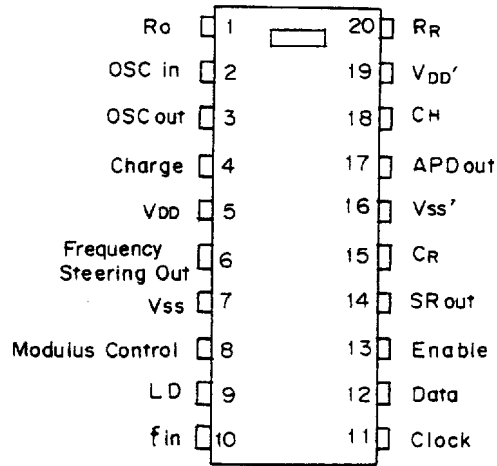

(TOP VIEW)

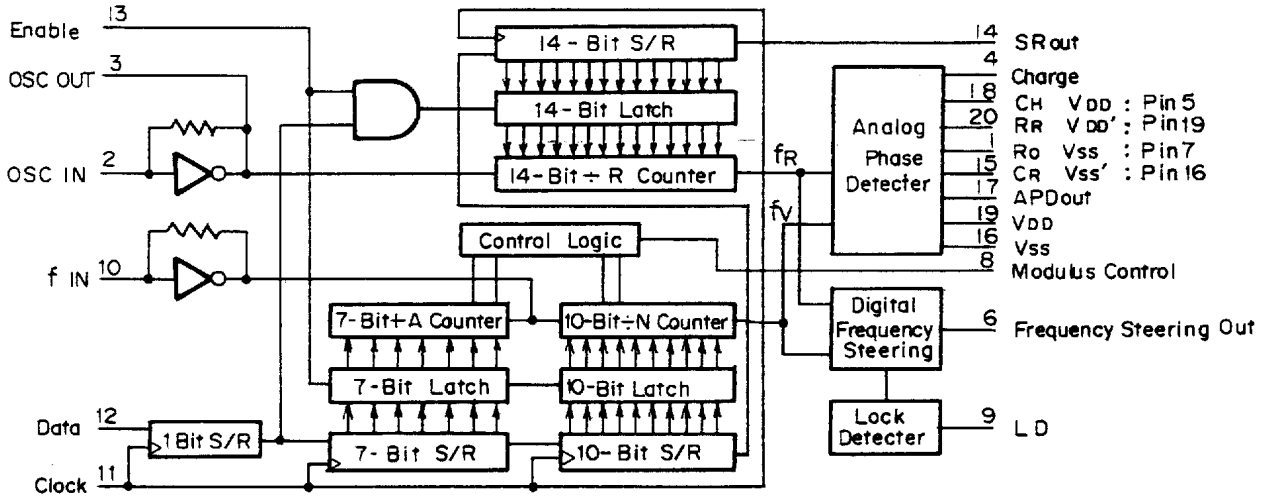

BLOCK DIAGRAM

RF BOARD
 DUAL OP-AMPLIFIER (U4, U9)

Equivalent Circuit (1/2 Circuit)

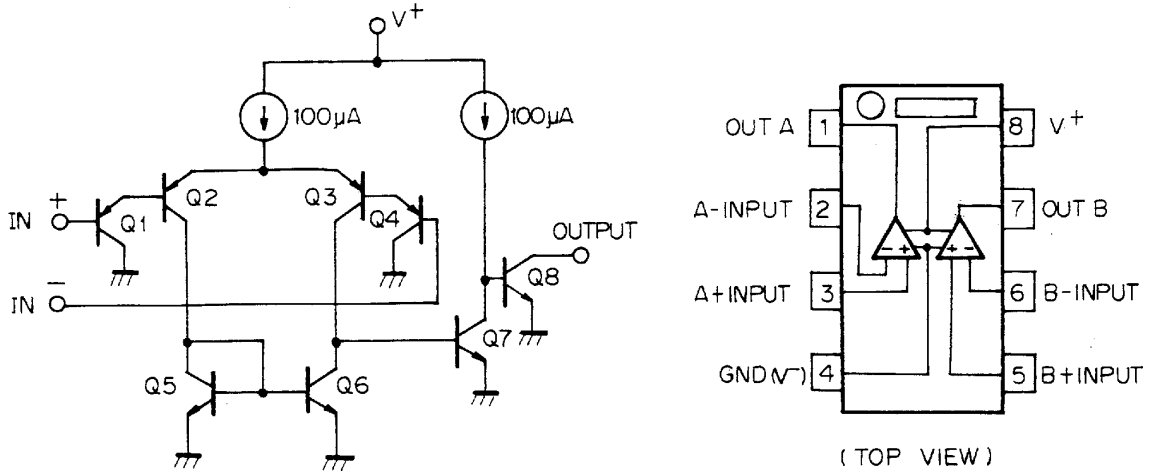

RF BOARD
 QUAD/BI-LATERAL SWITCH (U3)

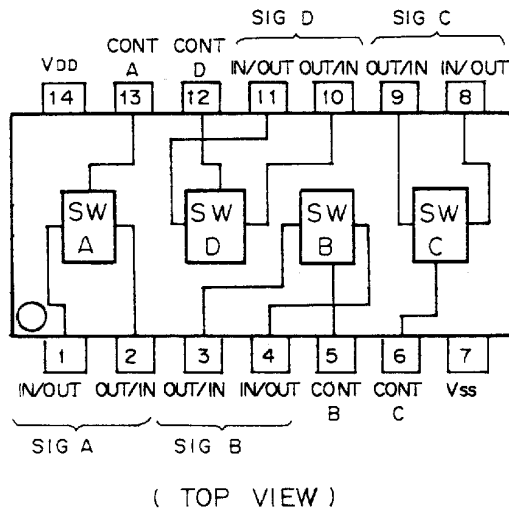

RF BOARD
VCO MODULE (U5)

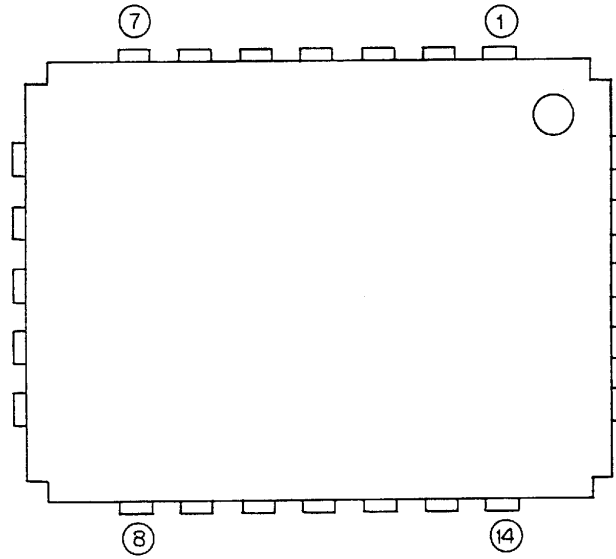

TOP VIEW

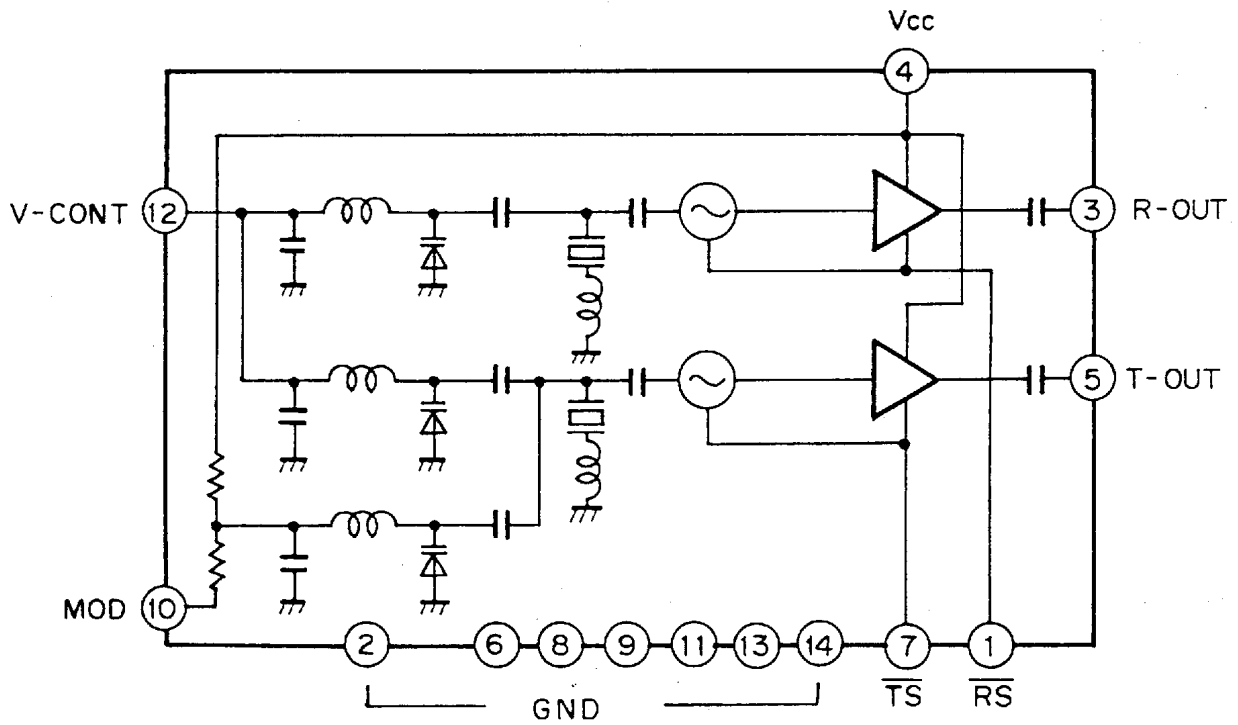

RF BOARD
REGULATOR (U6)

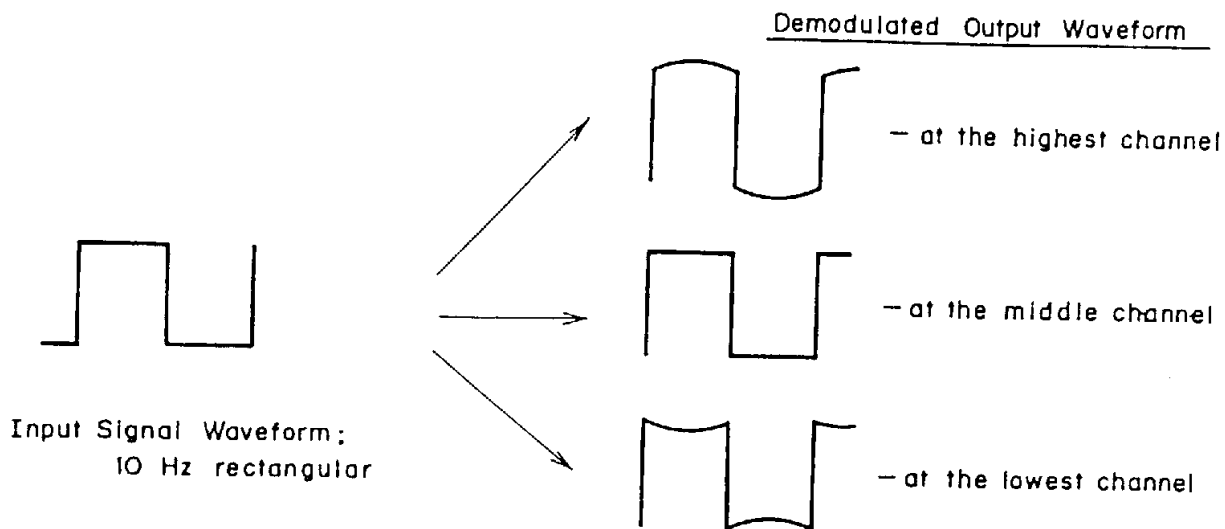
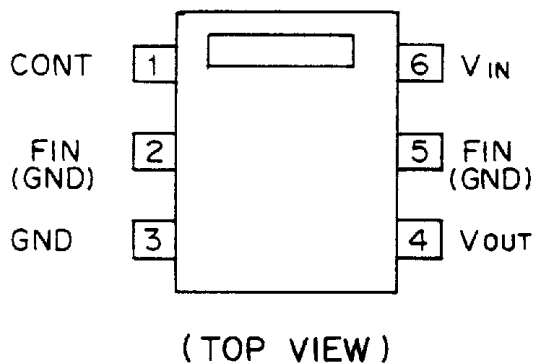

RF BOARD
POWER AMPLIFIER MODULE (U7)

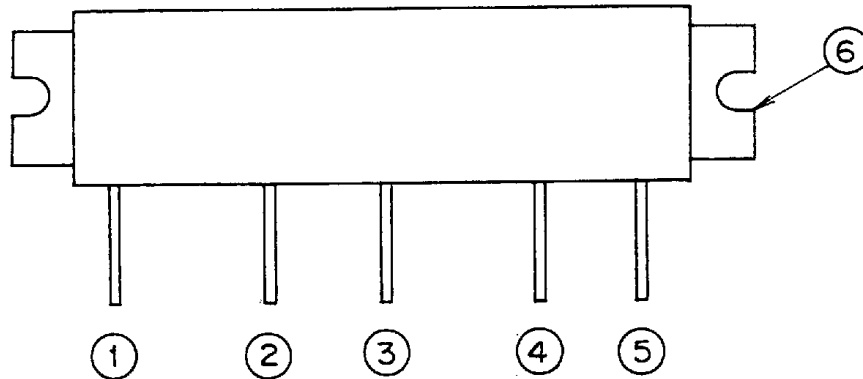

- ① RF INPUT (50 Ω)
- ② Vcc 1 (V-CONT)
- ③ Vcc 2 (7.5 V)
- ④ Vcc 3 (7.5 V)
- ⑤ RF OUTPUT (50 Ω)
- ⑥ FLANGE IS GROUND

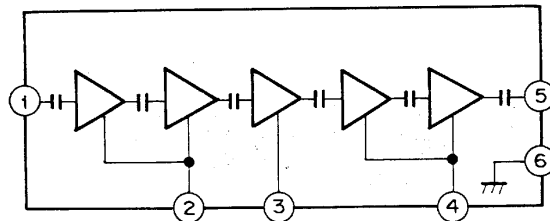

INTERNAL DIAGRAM

RF BOARD
LPF / DC / TR SW MODULE (U8)

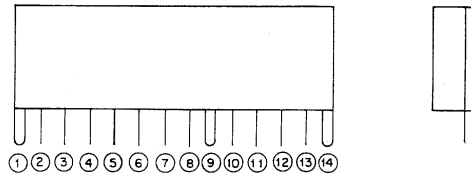

- ① CASE GND
- ② TX IN
- ③ GND
- ④ Vpf OUT
- ⑤ GND
- ⑥ BIAS (5V)
- ⑦ GND
- ⑧ T/R SWITCH
- ⑨ CASE GND
- ⑩ ANT
- ⑪ GND
- ⑫ GND
- ⑬ RX OUT
- ⑭ CASE GND

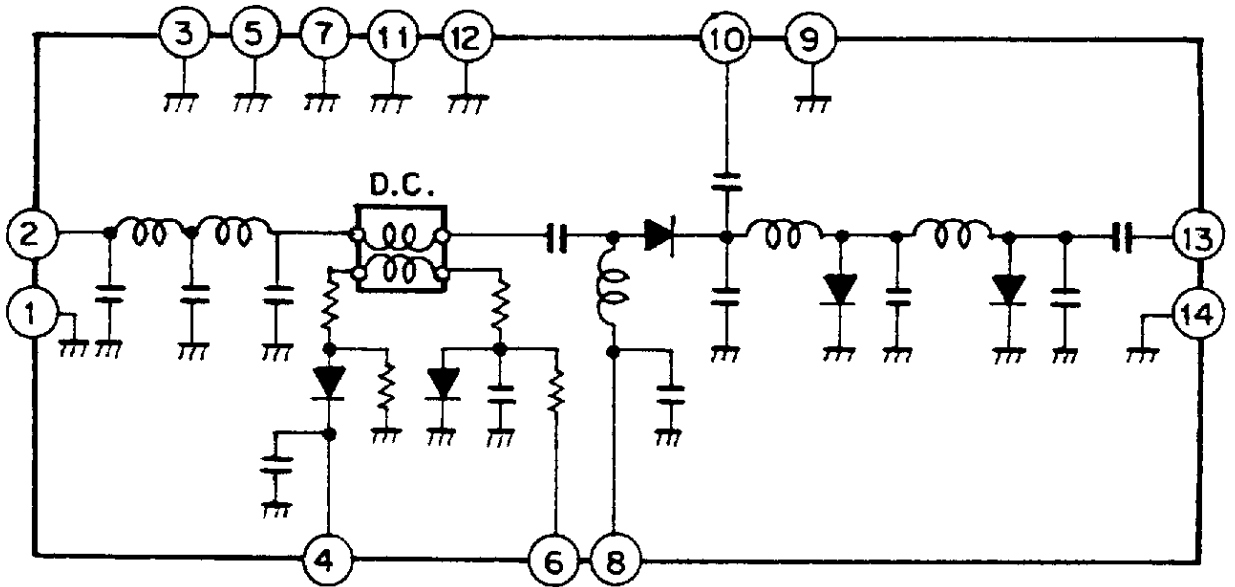

RF BOARD
IF IC (U11)

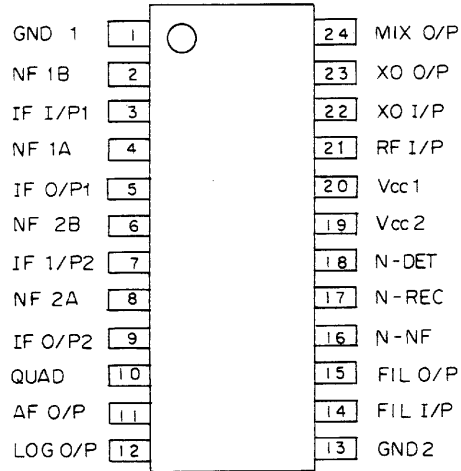

(TOP VIEW)

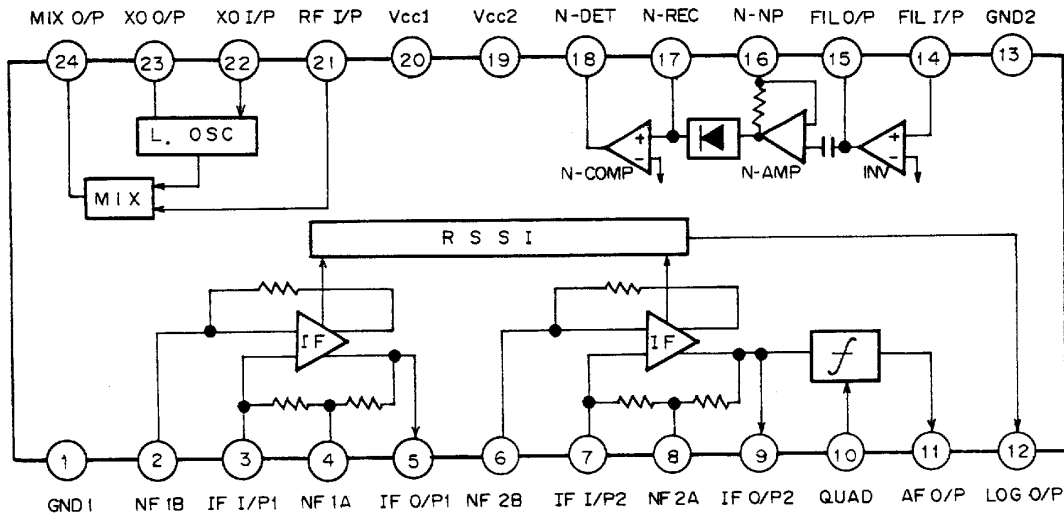

RF BOARD
BI - LATERAL SWITCH (U12)

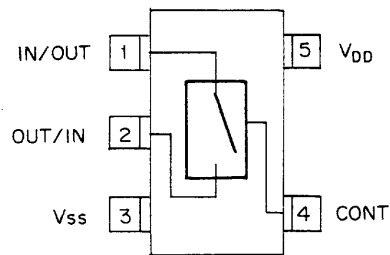

(TOP VIEW)

RF BOARD
VC TCXO MODULE (Z1)

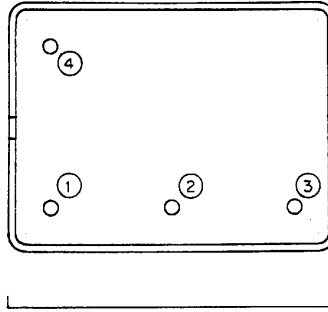

(BOTTOM VIEW)

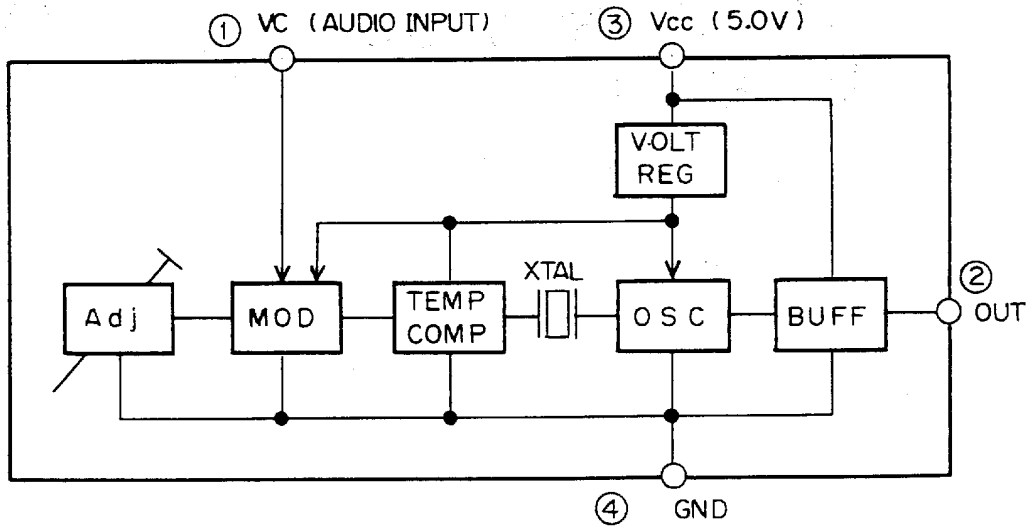

RF BOARD
DOUBLE BALANCED DIODE MIXER (DBM) (Z2)

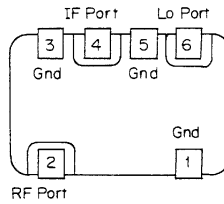
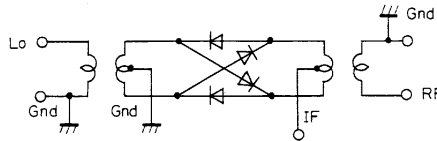

(BOTTOM VIEW)

RF BOARD

Q102, Q201

LED FLEX BOARD

Q2

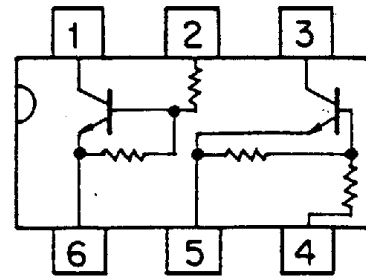

(TOP VIEW)

CONTROL BOARD

Q3

LCD / KB FLEX BOARD

Q5 ~ 11

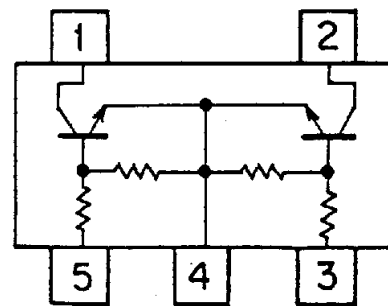

(TOP VIEW)

RF BOARD

Q105

CONTROL BOARD

Q8

LCD / KB FLEX BOARD

Q4

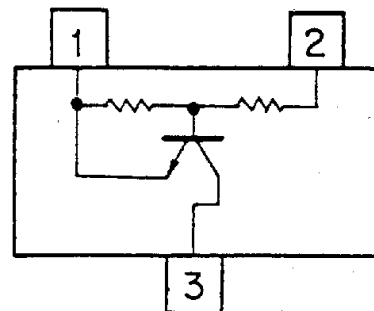

(TOP VIEW)

RF BOARD

Q205

LCD / KB FLEX BOARD

Q1, Q3

LED FLEX BOARD

Q1

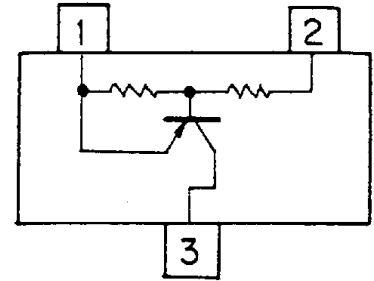

(TOP VIEW)

CONTROL BOARD

Q1

Q5

Q6

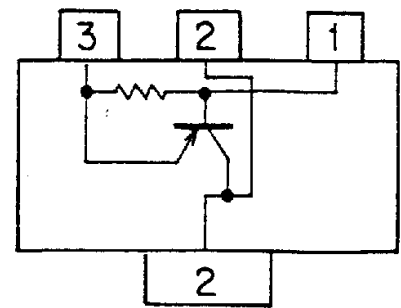

(TOP VIEW)

CONTROL BOARD

Q4

Q7

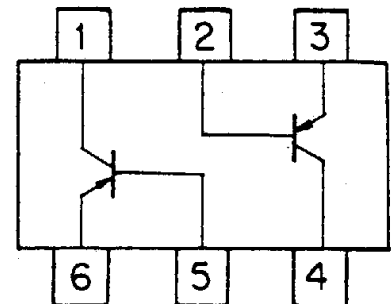

(TOP VIEW)

RF BOARD

Q203 (VHF, UHF)

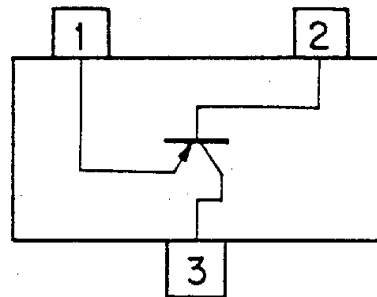

(TOP VIEW)

RF BOARD

Q101, Q103, Q104, Q106, Q107
 Q204,
 Q301 (VHF, UHF)
 Q302,

CONTROL BOARD

Q 2

LCD / KB FLEX BOARD

Q2

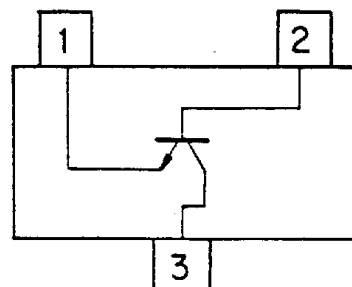

(TOP VIEW)

RF BOARD

Q 202

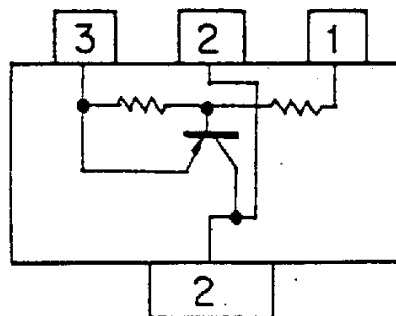

(TOP VIEW)

RF BOARD

Q301 (800, 900MHz)

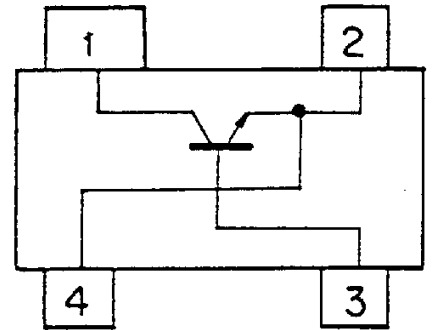

(TOP VIEW)

RF BOARD

Q203 (800, 900 MHz)

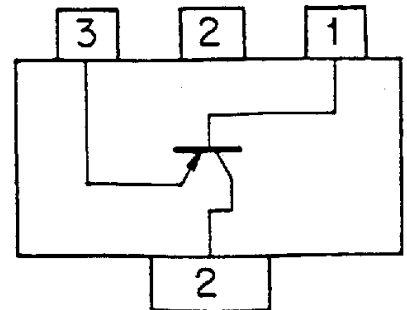

(TOP VIEW)

CONTROL BOARD

CR7 ~ 11

CR12

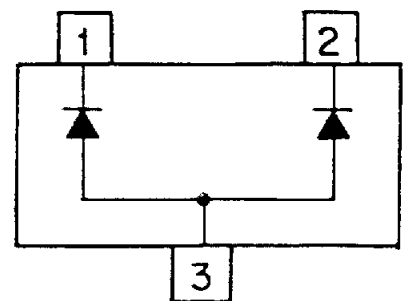

(TOP VIEW)

CONTROL BOARD

CR1 ~ 6
CR13 ~ 15

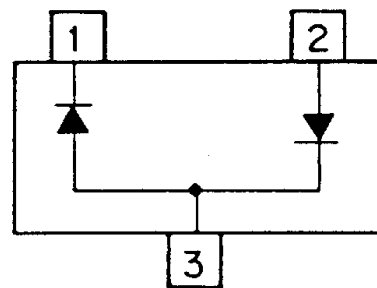

(TOP VIEW)

LCD / KB FLEX BOARD

CR 1

LCD / KB FLEX BOARD

CR 3

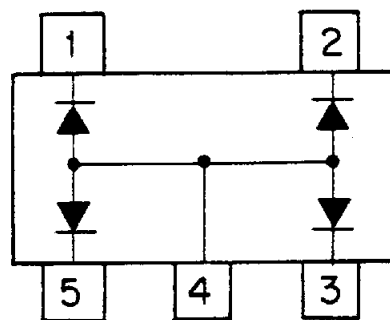

(TOP VIEW)

LED FLEX BOARD

CR 3

LCD / KB FLEX BOARD

CR 2
CR 4

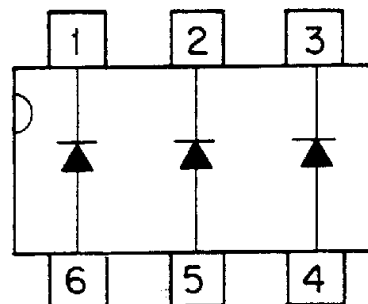

(TOP VIEW)

LED FLEX BOARD

CR 4

LED FLEX BOARD

DS 2

DS 3

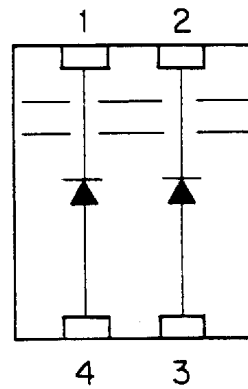

(TOP VIEW)

RF BOARD

CR 301

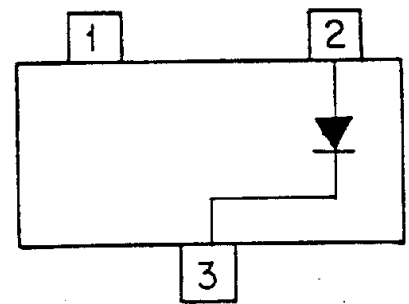

(TOP VIEW)

CONTROL BOARD

CR 16

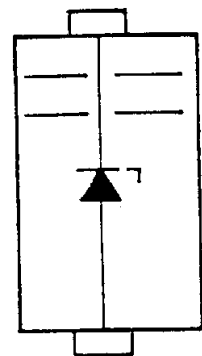

(TOP VIEW)

LCD/KB FLEX BOARD

DS1 ~ 4

LED FLEX BOARD

DS1

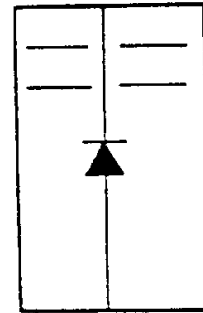

(TOP VIEW)