

Maintenance Manual

MASTR® III RF PACKAGE, VHF

TABLE OF CONTENTS

TRANSMIT SYNTHESIZER	LBI-38640
RECEIVE SYNTHESIZER	LBI-38641
RECEIVE RF MODULE	LBI-38642
IF MODULE	LBI-38643
POWER AMPLIFIER	LBI-38531
DUPLEXER	LBI-38763

TABLE OF CONTENTS

	<u>Page</u>
SPECIFICATIONS	1
REGULATORY APPROVALS	2
MODULE NUMBERS	2
ISOLATOR	3
ANTENNA SWITCH	3
INTERCONNECTION DIAGRAM	4

NOTICE!

This manual covers Ericsson and General Electric products manufactured and sold by Ericsson Inc.

NOTICE!

Repairs to this equipment should be made only by an authorized service technician or facility designated by the supplier. Any repairs, alterations or substitution of recommended parts made by the user to this equipment not approved by the manufacturer could void the user's authority to operate the equipment in addition to the manufacturer's warranty.

NOTICE!

The software contained in this device is copyrighted by the Ericsson Inc. Unpublished rights are reserved under the copyright laws of the United States.

SPECIFICATIONS

Table 1 - Station Specifications	
ITEM	SPECIFICATION
RECEIVER	
SENSITIVITY (12 dB SINAD)	-116 dBm [0.35 μV]
SELECTIVITY (25 kHz) (30 kHz)	-95 dB -100 dB
INTERMODULATION REJECTION	-90 dB
INTERMEDIATE FREQUENCY	21.4 MHz (low side injection)
IMAGE REJECTION	-100 dB
SPURIOUS RESPONSE REJECTION	-100 dB
HUM & NOISE (300-3000 Hz)	-55 dB
AUDIO RESPONSE (de-emphasis)	+1/-3 dB of 6 dB/OCTAVE (@ Line Output) +2/-8 dB of 6 dB/OCTAVE (@ Local Speaker)
FREQUENCY SPREAD (range) (full specification) (3 dB degradation)	136.0-151 MHz, 150.8-174 MHz 2 MHz 3 MHz
TRANSMITTER	
RATED POWER OUTPUT	110 Watts
FREQUENCY STABILITY	±1.5 ppm
CONDUCTED SPURIOUS EMISSIONS	-36 dBm
MODULATION DEVIATION	±5 kHz
FM HUM & NOISE (300-3000 Hz)	-55 dB
AUDIO RESPONSE (pre-emphasis)	+1/-3 dB of 6 dB/OCTAVE
FREQUENCY SPREAD (range) (full specification)	136.0-151 MHz, 150.8-174 MHz 136.0-151 MHz, 150.8-174 MHz

This manual is published by **Ericsson Inc.**, without any warranty. Improvements and changes to this manual necessitated by typographical errors, inaccuracies of current information, or improvements to programs and/or equipment, may be made by **Ericsson Inc.**, at any time and without notice. Such changes will be incorporated into new editions of this manual. No part of this manual may be reproduced or transmitted in any form or by any means, electronic or mechanical, including photocopying and recording, for any purpose, without the express written permission of **Ericsson Inc.**

REGULATORY APPROVALS

The following equipment authorization numbers have been granted:

<u>COUNTRY</u>	<u>REGULATORY APPROVAL</u>
United States	FCC (Parts 15, 22, 74, 80, 90) AXATR-197-A2
Canada	DOC (RSS-119) TR-197

MODULE NUMBERS

TRANSMIT SYNTHESIZER	19D902780G1
RECEIVE SYNTHESIZER (150.8-174 MHz)	19D902781G1
(136.0-151 MHz)	19D902781G2
RX FRONT END MODULE (150.8-174 MHz)	19D902782G2
(136.0-151 MHz)	19D902782G1
IF MODULE	19D902783G1
POWER AMPLIFIER	19D902797G1
LOW PASS FILTER	19D902856G1
ANTENNA SWITCH	19B235897P1
ISOLATOR	344A3406P2
DUPLEXER (150-162 MHz)	344A3371P1
DUPLEXER (162-174 MHz)	344A3371P2

Specifications

Frequency Range	136-174 MHz (no tuning)
Input Power	150 W (at max VSWR of 3.7:1)
Short Circuit Duration	100 ms max
Insertion Loss	0.3 dB max (25°C) 0.8 dB max (-40°C to +85°C)
Isolation	18 dB min (25°C) 15 dB min (-40°C to +85°C)

Description

The isolator has an internal load connected to an RF detector (sensor), the output from the sensor is continually monitored by the station for a fault condition (high VSWR). Once the station detects a sensor voltage above the threshold the transmitter is automatically de-keyed and a FAULT condition is reported.

IMPORTANT: The sensor output must be connected to P108 on the Interface Board when the Isolator is used, failure to make this connection with the Isolator installed will cause the isolator to be damaged under high VSWR conditions.

REFLECTED POWER	VSWR	TYPICAL SENSOR VOLTAGE
10W	1.70:1	3.9V
15W	1.92:1	4.8V
20W	2.15:1	5.7V
25W	2.38:1	6.4V
30W	2.62:1	6.8V

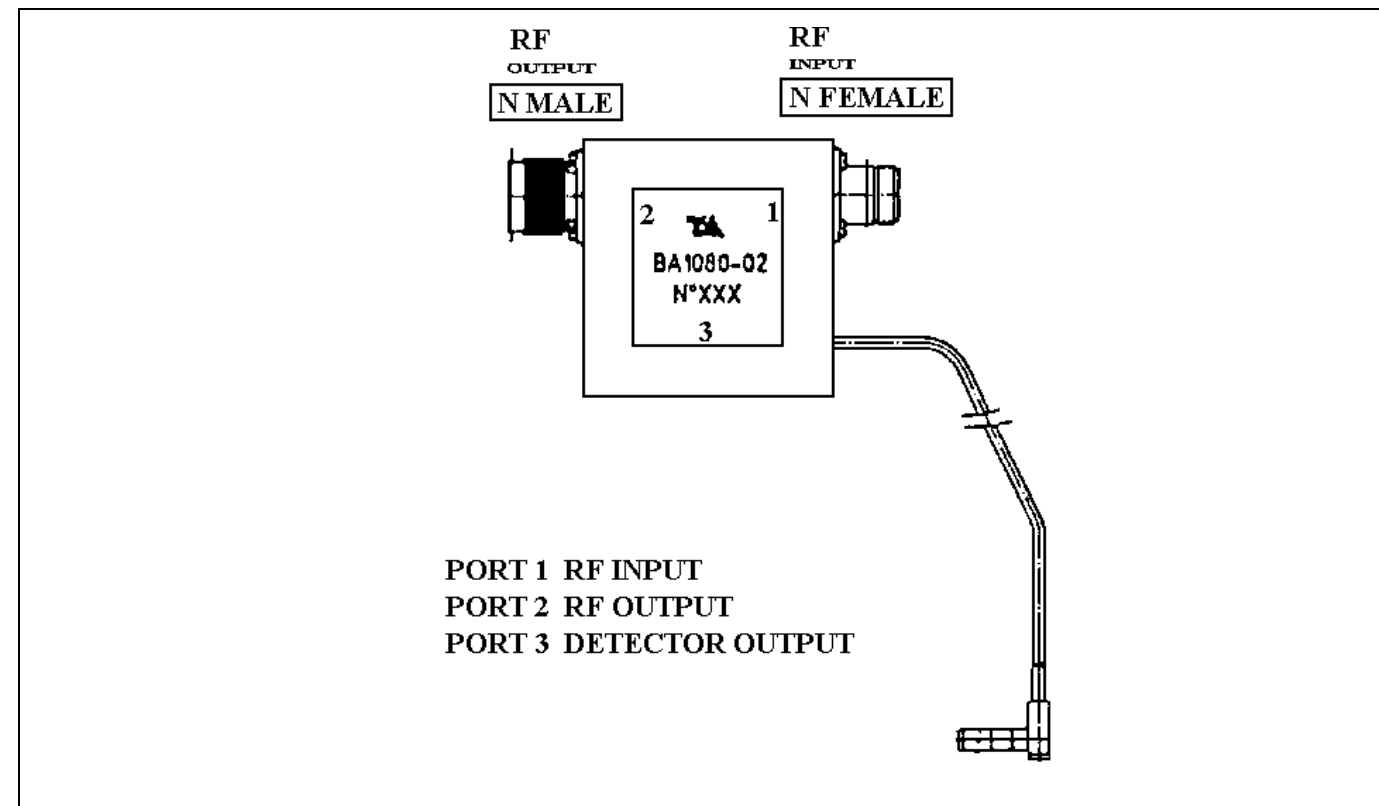

WARNING

DO NOT USE ISOLATOR WITHOUT CONNECTING THE SENSOR TO THE STATION

ISOLATOR
344A3406P1

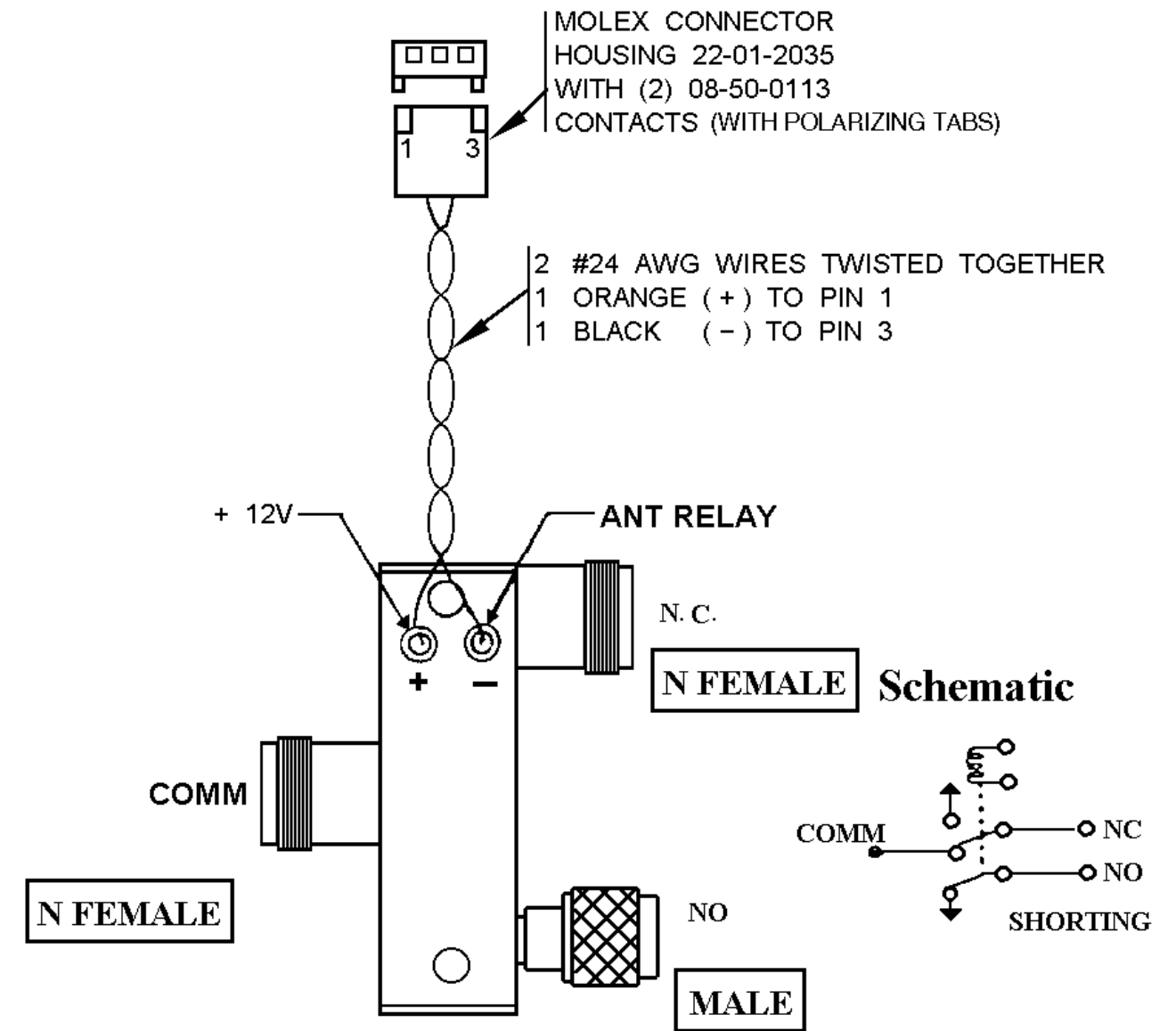

ANTENNA SWITCH
19B235897P2

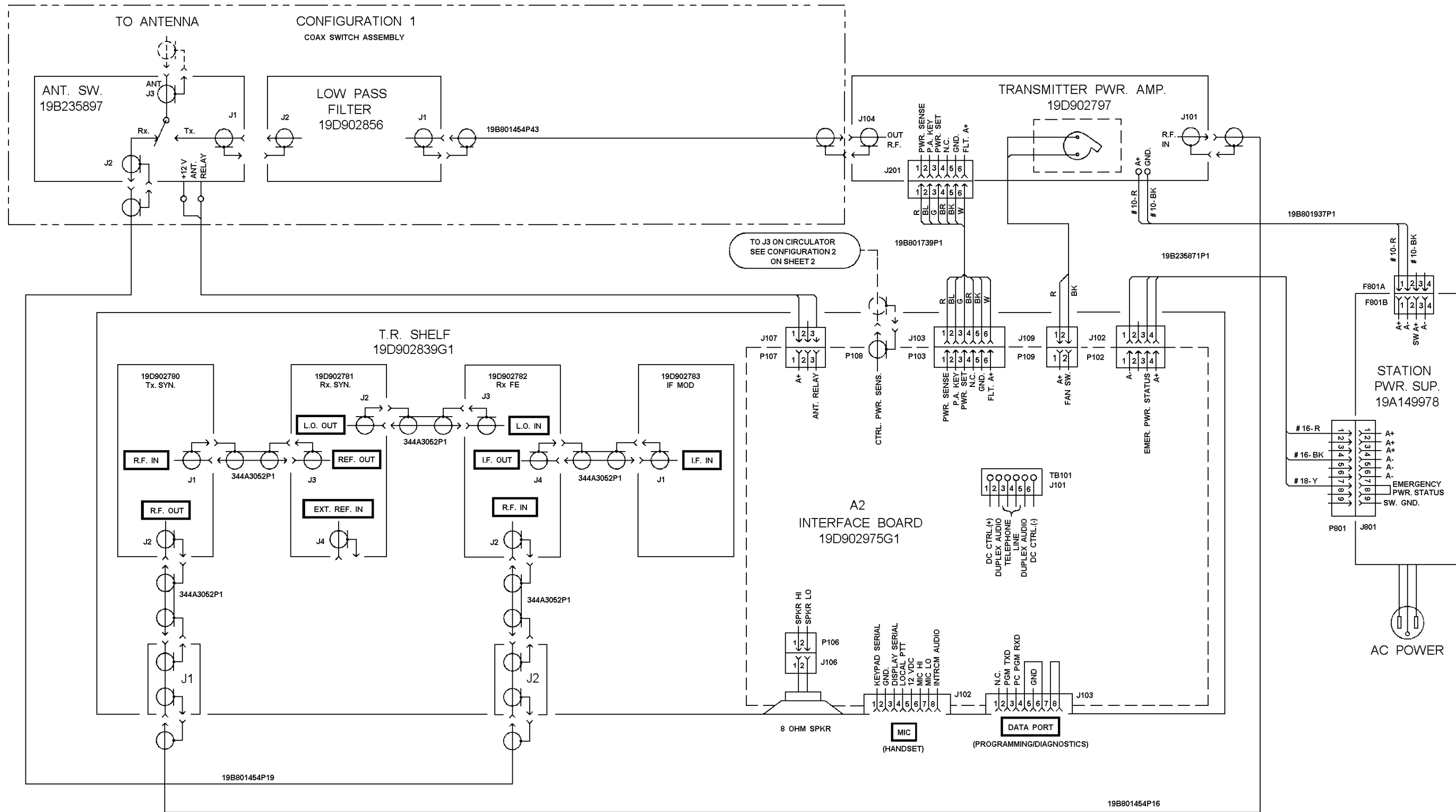

MASTR III STATION

(19D903635 Sh. 1, Rev. 4)

