

MAINTENANCE MANUAL

FRONT COVER ASSEMBLY

19D903620G1

TABLE OF CONTENTS

	<u>Page</u>
DESCRIPTION	1
CIRCUIT ANALYSIS	2
LCD BOARD	2
FLEX CIRCUITS	2
BATTERY PLATE	3
MICROPHONE AND SPEAKER	3
TROUBLESHOOTING	3
LCD BOARD PROBLEMS	3
KEYPAD FLEX PROBLEMS	4
DISPLAY/KEYPAD BACKLIGHTING PROBLEMS	4
SPEAKER TESTS	4
MICROPHONE TESTS	5
TESTING WITH THE FRONT COVER TEST ACCESSORY KITS	5
PARTS LISTS	
FRONT COVER ASSEMBLY	6
LCD BOARD	7
KEYPAD FLEX	7
MECHANICAL PARTS	8
OUTLINE DIAGRAMS	
LCD BOARD	10
KEYPAD FLEX	10
SPEAKER FLEX	11
UDC FLEX	11
INTERCONNECTION DIAGRAMS	
STANDARD APPLICATIONS	12
AEGIS AND VOICE GUARD APPLICATIONS	13
SCHEMATIC DIAGRAMS	
LCD BOARD	14
KEYPAD FLEX	16

DESCRIPTION

Front Cover Assembly 19D903620G1 is used with the M-PA portable radios. This assembly consists of LCD Board 19D902814P1, Keypad Flex 19D902810P1, Speaker Flex 19B235116G1, UDC Flex 19C337149G2, Battery Plate 19D902818P1, the die-cast aluminum front cover and the related hardware. The speaker and microphone are also included in this assembly.

The Control Board is installed into the 19D903620G1 assembly at the factory when the radio is assembled. This board contains all of the microcomputer and audio circuitry for the portable radio. It is not included with the 19D903620G1 assembly. See the maintenance manual specific to the Control Board for details on this board.

CIRCUIT ANALYSIS

LCD BOARD

Display Circuitry

M-PA radios utilize an LCD Board located behind the display bezel. When the display is updated, the Control Board serially loads the LCD Board with new display data. Interconnections on the Keypad Flex provide the serial connections between J4 on the Control Board and J10 on the LCD Board. The Keypad Flex also provides power and ground connections from the Control Board to the LCD Board.

Integrated circuit U1 is a 7225 LCD controller/driver "chip-on-board" IC that accepts the serial display data from the Control Board and provides multiplex operation for liquid crystal display DS3. This IC generates four (4) common plane and 32 segment drive signals for the LCD. An oscillator and divider circuit in U1 generates the multiplex clock. Resistor R1 sets the oscillator's frequency to approximately 130 kHz. Voltage divider R2 - R5 provides three (3) of the four (4) required LCD drive reference voltages. The 7225 contains a refresh memory bit for each of the 128 display segments. This memory allows the display to operate without constant updating from the Control Board.

The LCD is arranged with four common planes and 32 segments. Each display digit utilizes 4 segments in all 4 common planes for a total of 16 segments. The alphanumeric portion utilizes 14 segments and the remaining 2 segments are the status flags located above and below the respective digit. Liquid crystal displays respond to alternating currents through a segment rather than a constant current; the display is driven with a varying ac waveform. The four common planes are driven with constant waveforms and the segment waveforms are varied depending on whether segments are on or off.

A backlight driver circuit on the LCD Board drives the two (2) light-emitting diodes (LEDs) on each side of the display when a button or control on the radio is operated. This feature may be enabled or disabled on a per channel basis with the programmable options. Backlighting is controlled by the DISPLIT output (pin 13) of serial-to-parallel shift register U2. This signal, when high, saturates Q2 and Q1, lighting DS1 and DS2 from the power supply. On radios equipped with keypads, this switched source (LED DRIVE) is also supplied to J10 pins 6, 24 and 25 to light the LEDs under the keypad buttons.

Shift register U2 also has a logic output for LCD controller command/data (C/D) selection. Both the C/D and DISPLIT are clocked-out as a part of the same byte that sets the column outputs as explained in the following paragraph.

Keypad Circuitry

The keypad is arranged in a four (4) column by eight (8) row matrix. It is read by successively setting each column output to a logic 0 and examining the row inputs. Any row at logic 0 when examined indicates a closed switch. Three (3) columns are used to read the keypad switches and the fourth column reads group/channel switch S1. Specifically, columns 0 (COL 0) through 2 (COL 2) are utilized to read the switches on the flex and column 3 (COL 3) is used to read S1. See the charts on the Keypad Flex schematic for details on column-to-row connections and the coding of S1.

The I/O Microcontroller on the Control Board serially reads the keypad matrix as follows:

- Using CLOCK and DATA OUT, a byte is clocked into U2 on the LCD Board.
- The byte is then latched to the Q outputs of U2 via SR STB, the strobe pulse; one of the C0 - C3 columns is set low.
- SER ENA is pulsed to latch new instantaneous row data into shift register U3. Any row with a closed switch contact will latch a 0 into U3 for that row.
- Using CLOCK and DATA IN, the I/O Micro clocks the new row data into itself.
- This process is repeated twice every 50 ms, with the I/O Micro scanning each column by setting the subsequent column output low.

Scan and System model radios utilize LEDs on the Keypad Flex to backlight the keypad. Outputs from the backlight driver circuit on the LCD Board drive the associated LEDs.

FLEX CIRCUITS

Keypad Flex

With the exception of the on/off switch on the battery pack, all of the radio's operating controls are connected to the Keypad Flex. This flex circuit also interconnects the Control Board to the LCD Board.

Volume control (R20) and group/channel switch (S1) are soldered to this flex. The I/O Microcontroller on the Control Board uses the logic on the LCD Board to read the switches. On M-PA Scan and System model radios the four (4) switches on the top of the keypad (S2, S3, S4 and S5) are used. Keypad switches S6 through S17 are utilized in M-PA System model radios. Switches S18, S19 and S20 are the PTT, Monitor and Emergency/Home switches respectively.

UDC Flex

This flex circuit provides interconnections between the Control Board and the UDC. It also connects the internal microphone to the Control Board. UDC Flex interconnections are shown on the interconnection diagram.

Speaker Flex

The Speaker Flex connects the speaker to the Control Board. High and low speaker leads are available at the Battery Plate connector for test purposes. When the battery pack is installed, enabling (shorting) contacts on the pack connect the low-side of the speaker to the Control Board, thus enabling the speaker. Speaker Flex interconnections are included on the interconnection diagram.

BATTERY PLATE

The Battery Plate furnishes connections between the battery and the radio and it provides RF bypassing for the speaker. Fuse F1, housed in this plate, is externally accessible by removing the small cover on the bottom of the radio after the battery pack is removed. Battery Plate interconnections are shown on the interconnection diagram.

MICROPHONE AND SPEAKER

The internal electret microphone used in the Front Cover Assembly requires a dc bias. A pull-up resistor on the Control Board delivers this current to the MIC HI line (approximately 2.2 Vdc). Average speech into microphone will produce 10 - 30 mV rms on the MIC HI line.

The speaker is a 24 ohm, 1/2 watt device which connects to the 3-pin connector at the base of the Control Board. The Speaker Flex provides this interconnection.

TROUBLESHOOTING

The following outlines list component-level troubleshooting steps. Most of these tests can be completed without removing any assemblies from the Front Cover and with the Control Board in-place and operating. Avoid bending the flex circuits at sharp angles when they must be repositioned to gain access to a test point.

LCD BOARD PROBLEMS

1. Inspect the LCD for cracks or other damage.
2. Verify 5.4 Vdc (nominal) supply power from the Control Board's regulator is being delivered to the LCD Board via the Keypad Flex. The supply voltage varies depending upon the type of Control Board installed; see the Control Board maintenance manual for the specific supply voltage. The LCD Board and Keypad Flex consume less than 1.6 mA with all segments and backlighting off. The high-side of the volume potentiometer is a convenient test point to verify power is applied to the Keypad Flex. On the LCD Board, power should be present on the lower terminal of R11 (nearest Q2) and on both terminals of R12. Less than 1.0 Vdc should be across R12.
3. If the display and keypad are inoperative or intermittent first suspect the J4/P4 connection at the Control Board or the J10/P10 connection between the LCD Board and Keypad Flex. J10/P10 inspection will require removal of the Control Board and the shield between it and the Keypad Flex.
4. Problems with shift register U2 will also cause display and keypad problems. If U2 is not operating correctly the keypad columns are most likely not being sequentially set low and the display command/data (C/D) output to U1 is probably not pulsing. Monitor COL 3 at the common (center) terminal of group/channel switch S1 for low-going pulses. If none are present, verify the Control Board is clocking data into U2. See the Control Board service information for specific keypad scanning waveforms. If these pulses appear normal, U2 is most likely defective and LCD Board replacement will be required.
5. Check voltage divider R2 - R5 and verify proper LCD reference voltages are being delivered to U1 pins 3, 4 and 5. The measurements should be within ± 0.5 Vdc of the values listed on the Keypad Flex schematic.

6. Monitor U1 pin 2 with an oscilloscope; a test pad is provided between U1 and R2. Negative-going pulse pairs should be present spaced 4 milliseconds apart. The pulses will be approximately 30 us wide. Suspect R1 or U1 if the pulses are not present.
7. At the plated-thru holes near U1 on the LCD Board, monitor CLOCK and DATA OUT from the Control Board to U1 pins 8 and 9 respectively. These signals from the I/O Micro are writing to U1 and U2, reading U3 and writing/reading the Audio Processor IC on the Control Board.

NOTE

Since the ICs on the LCD Board are "chip-on-board" devices, failure of any IC on the board will require LCD Board replacement.

KEYPAD FLEX PROBLEMS

1. If only a few buttons appear intermittent, verify the associated contacts are clean. On Scan and System model radios, the front panel and keypad can be removed to gain access to the front keypad contacts.
2. If the Control Knob (group/channel switch) is the only problem item, first suspect switch S1 or the associated flex connections. There may also be a problem with the COL 3 output from U2 on the LCD Board or one of the four (4) diode-isolated row inputs (ROW 0A - ROW 3A). See **LCD BOARD PROBLEMS** for details on COL 3 troubleshooting.
3. If only some of the positions of the Control Knob are inconsistent with the radio's programming and/or all switches in a single row on the keypad are inoperative there is a row problem between the switch matrix and U3 on the LCD Board. Suspect the J10/P10 connections or one of the series connecting 1K resistors, the 100K pull-ups or a bad U3 input. For example, if R23 on the LCD Board opens (series 1K resistor for ROW 0), the PTT Button and some positions of the Control Knob will not operate, but the Monitor Button will operate normally.

4. Suspect D5, D6 or D7 if all rows in a single column are inoperative and the corresponding U2 output is OK. For example, if D7 opens (COL 0), the Monitor, PTT and Emergency/Home Buttons will not operate, but the Control Knob will operate normally. Also suspect the J10/P10 connections.
5. Monitor DATA IN at J4/P4 pin 4 for a change of pulse pattern when a button is pressed or the Control Knob is rotated.

DISPLAY/KEYPAD BACKLIGHTING PROBLEMS

1. With the PC Programmer, verify backlighting is enabled for the particular channel(s).
2. Monitor the junction of R8, R9 and the base of Q2. This point should go from 0 Vdc to approximately 0.5 Vdc when the backlight turns on. Suspect U2 on the LCD Board if the level does not change or if it is inverted.
3. On the LCD Board, check Q2's collector. It should be less than 1.0 Vdc when the backlight is on.
4. On the LCD Board, check Q1's collector. It should be greater than 4.0 Vdc with backlighting on.
5. If there is a problem with keypad backlighting on Scan and System model radios (with LCD backlighting OK), suspect the LED DRIVE contacts at J10/P10.

SPEAKER TESTS

The internal speaker can be quickly tested by applying audio from a signal generator to the appropriate pins on the Battery Plate with the battery removed. With the Front Cover face-down on the bench, apply audio from a signal generator to the second and third pins from the left. The speaker impedance is 24 ohms and it is a 1/2-Watt device. See the Control Board's service information for receive audio problems with the Control Board.

MICROPHONE TESTS

A dc bias of approximately 2.2 Vdc should be present on the internal MIC HI line (J1/P1 pin 14). If this voltage is near 2.7 Vdc, suspect an open UDC Flex or MK1. Average speech into the mic should produce 10 - 30 mV rms on the MIC HI line. See the Control Board's service information for transmit audio problems with the Control Board.

TESTING WITH THE FRONT COVER TEST ACCESSORY KITS

LCD Board and Keypad Flex can be tested without the Control Board using Front Cover Test Accessory Kits SPK9010 and SPK9011 and an IBM PC or compatible computer. Procedures outlined in the Front Cover Test Accessory

maintenance manual (LBI-38518) list the steps required to install Adapter Board 19D902562P3 and the Front Cover Test Cable 19D902562P5 and make the connections to an IBM PC or compatible computer's parallel printer port. Using this set-up, the LCD Board, Keypad Flex, volume potentiometer, group/channel switch and the microphone can all be tested without removing them from the Front Cover. Since the Control Board is not required in this test set-up, substitution permits a problem to be quickly narrowed to either the Control Board or the circuits in the Front Cover.

LCD Extender Plate and Clamp 19D902562P1, LCD Test Cable 19D902562P2 and the "D - TEST DISPLAY " selection of the MPATEST program cannot be used to test LCD Board 19D902814P1. Use only the "F - TEST FRONT COVER OR KEYPAD" selection in the MPATEST program.



Ericsson GE Mobile Communications Inc.
Mountain View Road • Lynchburg, Virginia 24502

Printed in U.S.A.

**FRONT COVER ASSEMBLY
19D903620G1**

ISSUE 1

SYMBOL	PART NUMBER	DESCRIPTION
		LCD BOARD 19D902814P1 (See Separate Parts List).
		KEYPAD FLEX 19D902810P1 (See Separate Parts List).
		SPEAKER FLEX 19B235116G1
2	19D438674P1	Speaker Flex. (Bare).
3	19A704852P163	Plug: 3-Pin, Gold Plated.
		BATTERY PLATE 19D902818P1
		UDC FLEX 19C337149G2
2	19D438711P1	UDC connector.
3	19D902265P1	PTT keypad.
5	19D902811P1	UDC Flex. (Bare).
		FRONT COVER ASSEMBLY
		----- FUSES -----
F1	19A702169P11	Enclosed link; rated 5 amps @ 125 v; sim to Littelfuse 255003.
		----- LOUDSPEAKERS -----
LS1	19A149673P1	Round: Water Proof, 24 ohms, 1/2 w.; sim to Line Electric Co. VS-50W24.
		----- MICROPHONES -----
MK1	19A701301P3	Cartridge: Electret.
		----- RESISTORS -----
R20	19A134528P4	Variable: 50K ohms $\pm 10\%$, 1/2 w.; sim to Allen Bradley Type SP.
		----- SWITCHES -----
S1	19A149612P1	Rotary: 16 Position Gray Code; sim to Cole #1800-4240 or Grayhill 26YY Special.
		----- MISCELLANEOUS -----
2	19D902812P1	Cover, Front: Aluminum.
3	19D902813P1	Shield, Chassis. (Under Control Board).
4	19B235140P1	Pad. (Used at P1).
5	19B235140P2	Pad. (Used at P4).
6	19A705701P104	Screw, Machine: Torx, Pan Head; M2 x 4. (Secures LCD Board).
7	19D438683P1	Plate, Stop. (Used under Group/ Channel Control).
8	19B802000P1	Strip, Adhesive. (Secures Control Panel).
9	19C852139P1	Button, Emergency: Red.
10	19D902815P1	Panel, Control.

SYMBOL	PART NUMBER	DESCRIPTION
11	19A127319P1	Nut: 1/4-32. (Secures R20).
12	19A127319P2	Nut: 1/4-28. (Secures S1).
13	19C852161G2	Knob, Volume. (Includes Set Screw L19BP10005B17)
14	19C852161G1	Knob, Group/Channel. (Includes Set Screw L19BP10005B17).
15	19A149546P1	Nut, UDC.
16	19C337462P1	Gasket. (Used with LS1 and MK1).
17	19B235074P1	Cover, Fuse. (Used with Battery Plate).
18	19A702362P102	Screw, Machine: Torx, Flat Head, M2 x 2.75. (Secures Battery Plate, quantity required = 2).
19	19A705701P4	Screw, Machine: Torx, Pan Head; M1.6 x 4. (Secures Battery Plate Ground Contact).
20	19B801539P3	Pad, Friction.
21	19B801539P4	Pad, Friction. (Located below UDC/ Monitor PTT Assembly).
22	4037064P25	Washer, non-metallic. (Used with R20).
25	19A701648P4	Adhesive/Sealant (As required).
26	344A3243P1	Insulator. (Used with MK1).
27	19A149819P1	Adhesive, Cyanoacry (As required).
28	19C851997P1	Gasket, Speaker.
29	344A3854P1	Insulator. (Used on Item 3 Shield at LS1).
30	19A705940P104	Screw, Machine: Torx, Flat Head; M2 x 4. (Secures Battery Plate, quantity required = 1).
31	19B234763P26	Pad.
32	344A4026P1	Plate, Steel. (Used at J10/P10).
33	19A705701P6	Screw, Machine: Torx, Pan Head; M1.6 x 6. (Used at J10/P10, quantity required = 2).
34	344A4027P1	Pad, Rubber. (Used at J10/P10)
35	19B234763P27	Pad, Adhesive Lined.
36	19B801968P1	Support, Emergency.

* COMPONENTS, ADDED, DELETED OR CHANGED BY PRODUCTION CHANGES

LCD BOARD
19D902814P1

ISSUE 1

SYMBOL	PART NUMBER	DESCRIPTION
		— — — — CAPACITORS — — — —
C1 thru C4	19A702052P5	Ceramic: 1000 pF ±10%, 50 VDCW.
C5	19A702052P14	Ceramic: 0.01 uF ±10%, 50 VDCW.
C6 and C7	19A705205P2	Tantalum: 1 uF, 16 VDCW; sim to Sprague 293D.
		— — — — DIODES — — — —
D1 thru D7	19A700155P2	Silicon: 100 mA, 35 PIV.
		— — — — INDICATING DEVICES — — — —
DS1 and DS2	19A705713P2	LED: Green; sim to HLMP-6500.
DS3	19B801594P1	LCD: sim to LXD 57IE3F99KGSZ.
		— — — — JACKS — — — —
J10		Part of Printed Wire Board.
		— — — — TRANSISTORS — — — —
Q1	19A700059P2	Silicon, PNP: sim to MMBT3906, low profile
Q2	19A700076P2	Silicon, NPN: sim to MMBT3904, low profile.
		— — — — RESISTORS — — — —
R1	19B801251P184	Metal film: 180K ohms ±5%, 1/10 w.
R2 thru R4	19B801251P103	Metal film: 10K ohms ±5%, 1/10 w.
R5	19B801251P472	Metal film: 4.7K ohms ±5%, 1/10 w.
R6	19B801251P104	Metal film: 100K ohms ±5%, 1/10 w.
R7	19B801251P101	Metal film: 100 ohms ±5%, 1/10 w.
R8	19B801251P473	Metal film: 47K ohms ±5%, 1/10 w.
R9	19B801251P223	Metal film: 22K ohms ±5%, 1/10 w.
R10	19B801251P152	Metal film: 1.5K ohms ±5%, 1/10 w.
R11	19B801251P332	Metal film: 3.3K ohms ±5%, 1/10 w.
R12	19B801251P471	Metal film: 470 ohms ±5%, 1/10 w.
R15 thru R22	19B801251P104	Metal film: 100K ohms ±5%, 1/10 w.
R23 thru R30	19B801251P102	Metal film: 1K ohms ±5%, 1/10 w.
R31 thru R33	19B801251P221	Metal film: 220 ohms ±5%, 1/10 w.

SYMBOL	PART NUMBER	DESCRIPTION
		— — INTEGRATED CIRCUITS — —
U1		NOTE: U1 - U3 are non-replaceable "chip-on-board" components. LCD Controller/Driver: sim to NEC uPD7225G.
U2		Digital: 8-Bit Shift Register; sim to CD4094.
U3		Digital: 8-Bit Shift Register; sim to MC14021.
		— — — — MISCELLANEOUS — — — —
		(See Drawing 19D902814, Sh. 3)
3	19C337137P1	Frame, LCD
4	19A703685P4	Connector, LCD.
5	19D438686P1	Diffuser, Light.

KEYPAD FLEX
19D902810P1

ISSUE 1

SYMBOL	PART NUMBER	DESCRIPTION
		— — — — DIODES — — — —
D1	19A134587P2	Silicon: 2 Diodes in series, Common Cathode; sim to BAV 70 and BAV 74.
		— — — — INDICATING DEVICES — — — —
DS1 thru DS6		Diode: Green LED; sim to HSMG-TX100.
		— — — — PLUGS — — — —
P4		Part of Flex Board.
P10		Part of Flex Board.
		— — — — RESISTORS — — — —
R20		Part of Front Cover Assembly.
		— — — — SWITCHES — — — —
S1		Part of Front Cover Assembly.
S2 thru S20		Part of Flex Board.
		— — — — MISCELLANEOUS — — — —
	19B235119P1	Dome Switch Snap. (Used with S18 and S19).

* COMPONENTS, ADDED, DELETED OR CHANGED BY PRODUCTION CHANGES

* COMPONENTS, ADDED, DELETED OR CHANGED BY PRODUCTION CHANGES

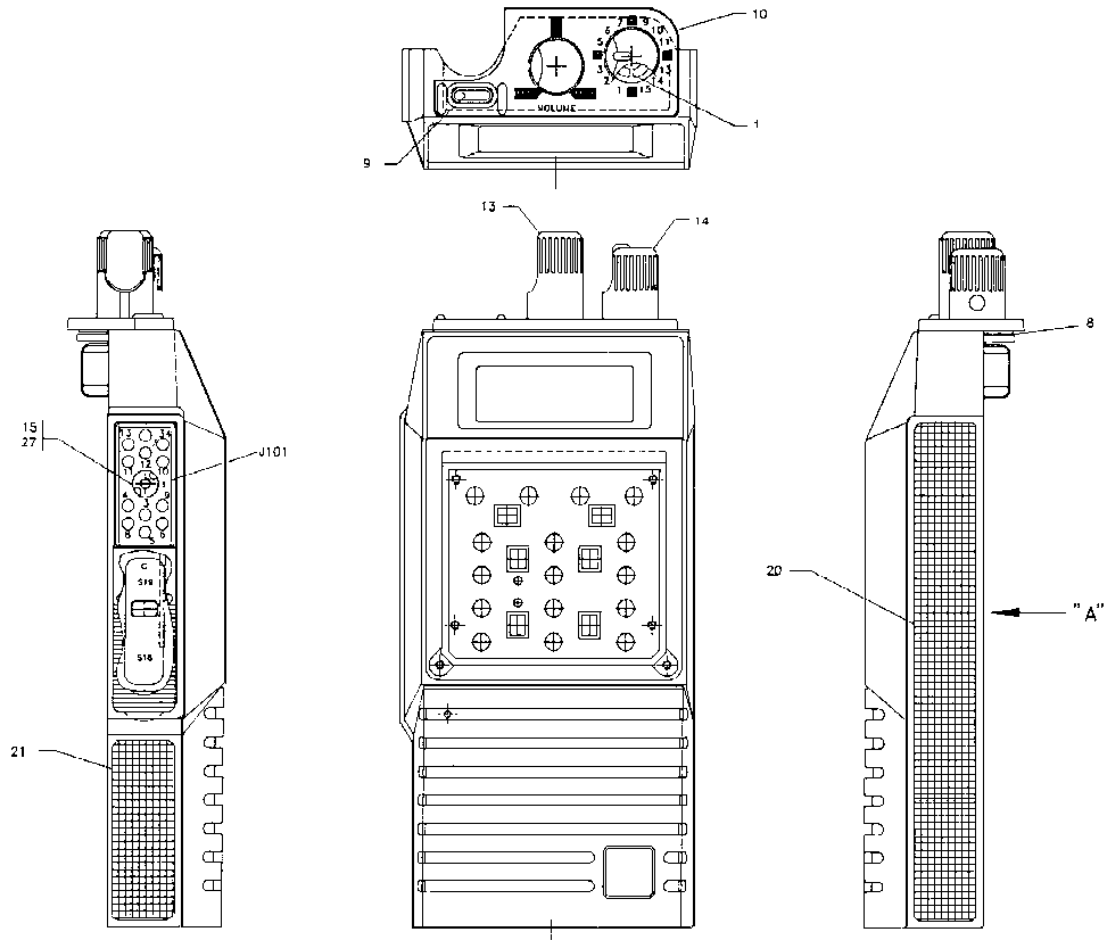

**FRONT COVER ASSEMBLY
19D903620G1**

(19D903620, Sh. 2, Rev. 1)

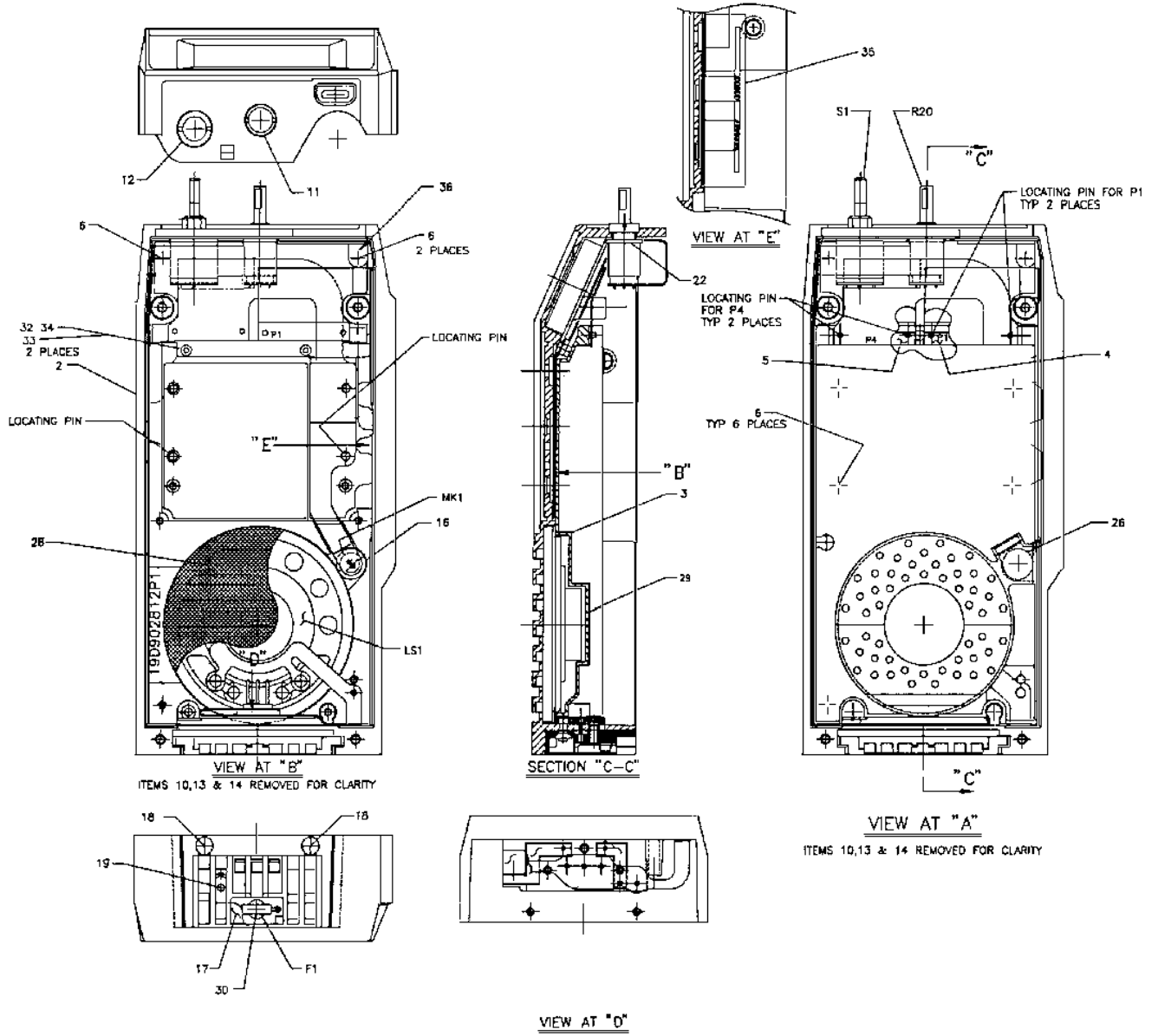

**FRONT COVER ASSEMBLY
19D903620G1**

(19D903620, Sh. 1, Rev. 4)

COMPONENT SIDE

SOLDER SIDE

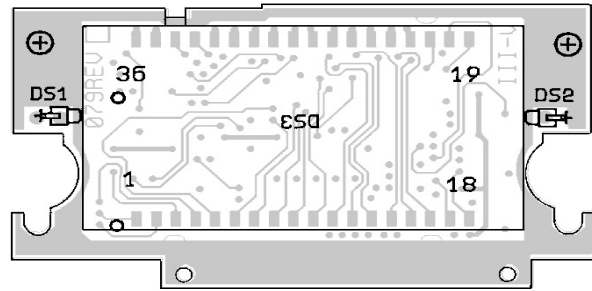
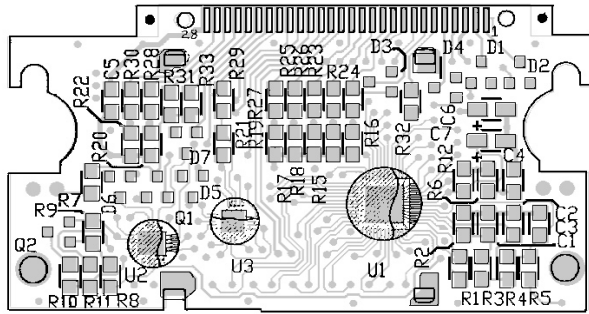

**LCD BOARD
19D902814P1**

(19D902814, Sh. 2, Rev. 1)
(5000079-01, Sh. 4, Rev. C)
(5000079-01, Sh. 7, Rev. C)



CAUTION

OBSERVE PRECAUTIONS
FOR HANDLING
ELECTROSTATIC
SENSITIVE
DEVICES

COMPONENT SIDE

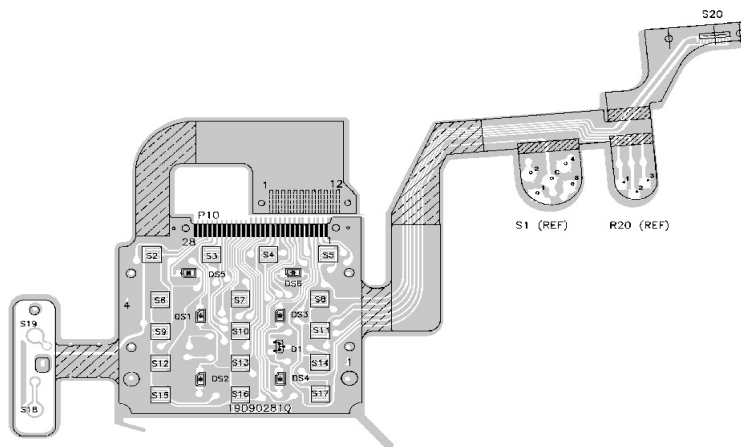

SOLDER SIDE

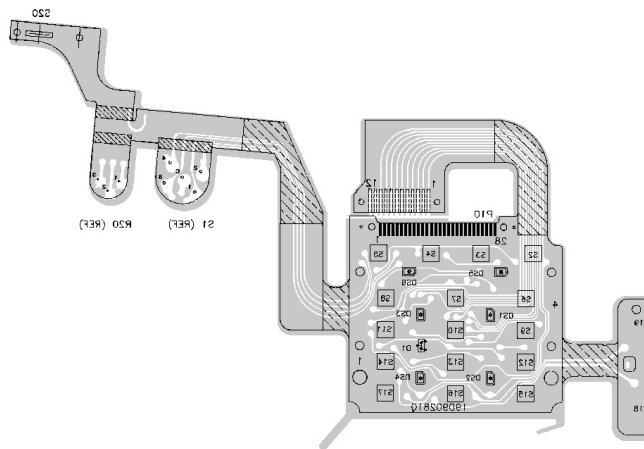

**KEYPAD FLEX
19D902810P1**

(19D902810, Sh. 1, Rev. 3)

COMPONENT SIDE

19D438674P1

SOLDER SIDE

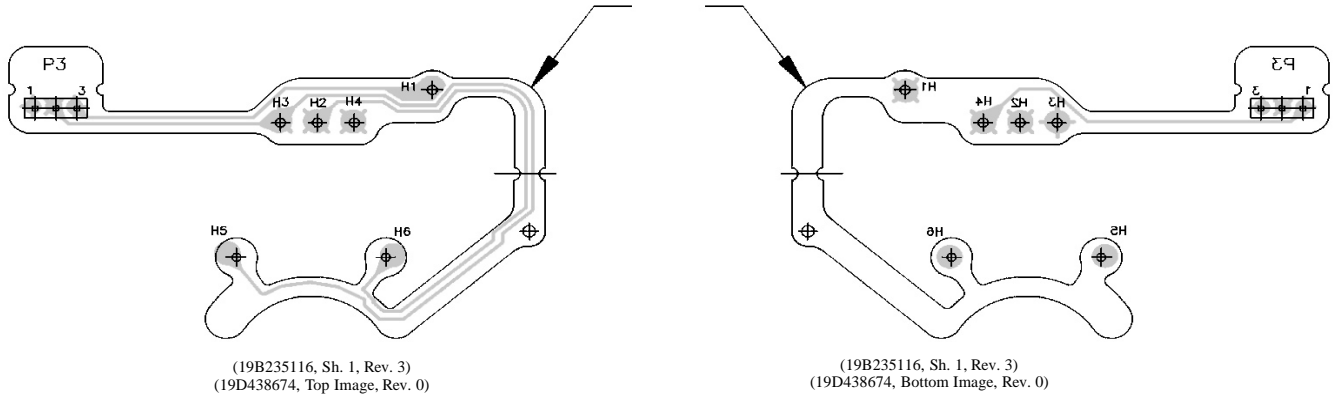

**SPEAKER FLEX
19B235116G1**

(19B235116, Sh. 1, Rev. 3)
(19D438674, Top Image, Rev. 0)
(19D438674, Bottom Image, Rev. 0)

COMPONENT SIDE

SOLDER SIDE

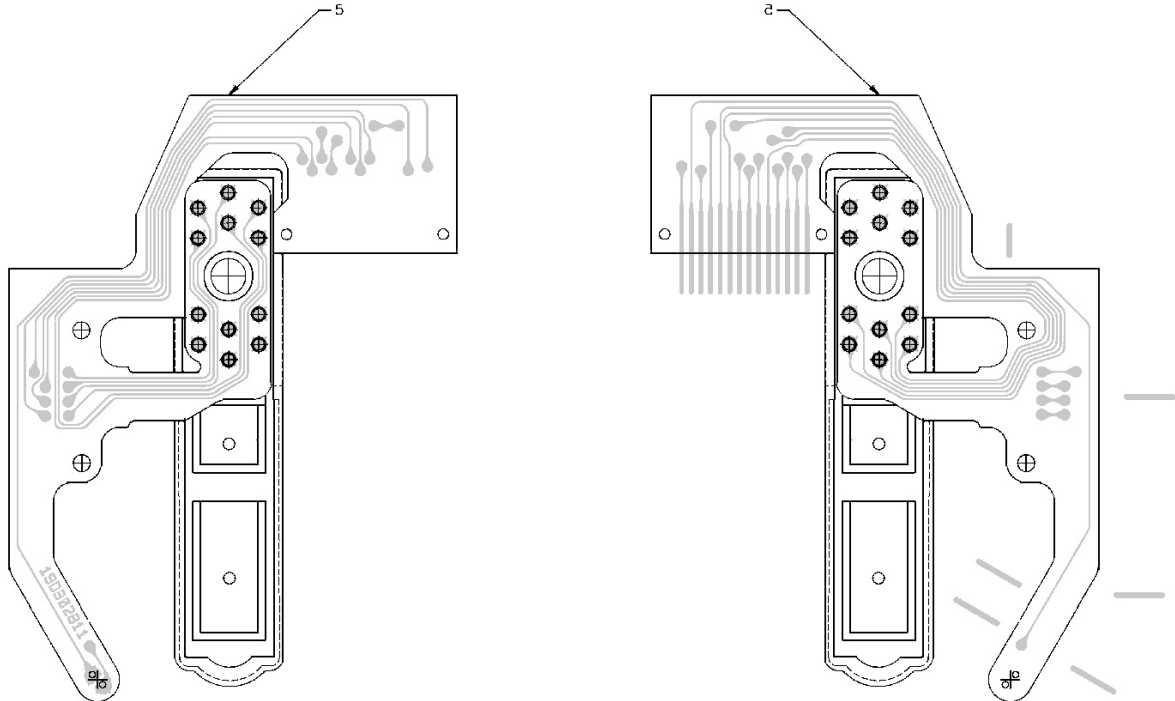

**UDC FLEX
19C337149G2**

(19C337149, Sh. 2, Rev. 0)
(19D902811, Top Image)
(19D902811, Bottom Image)

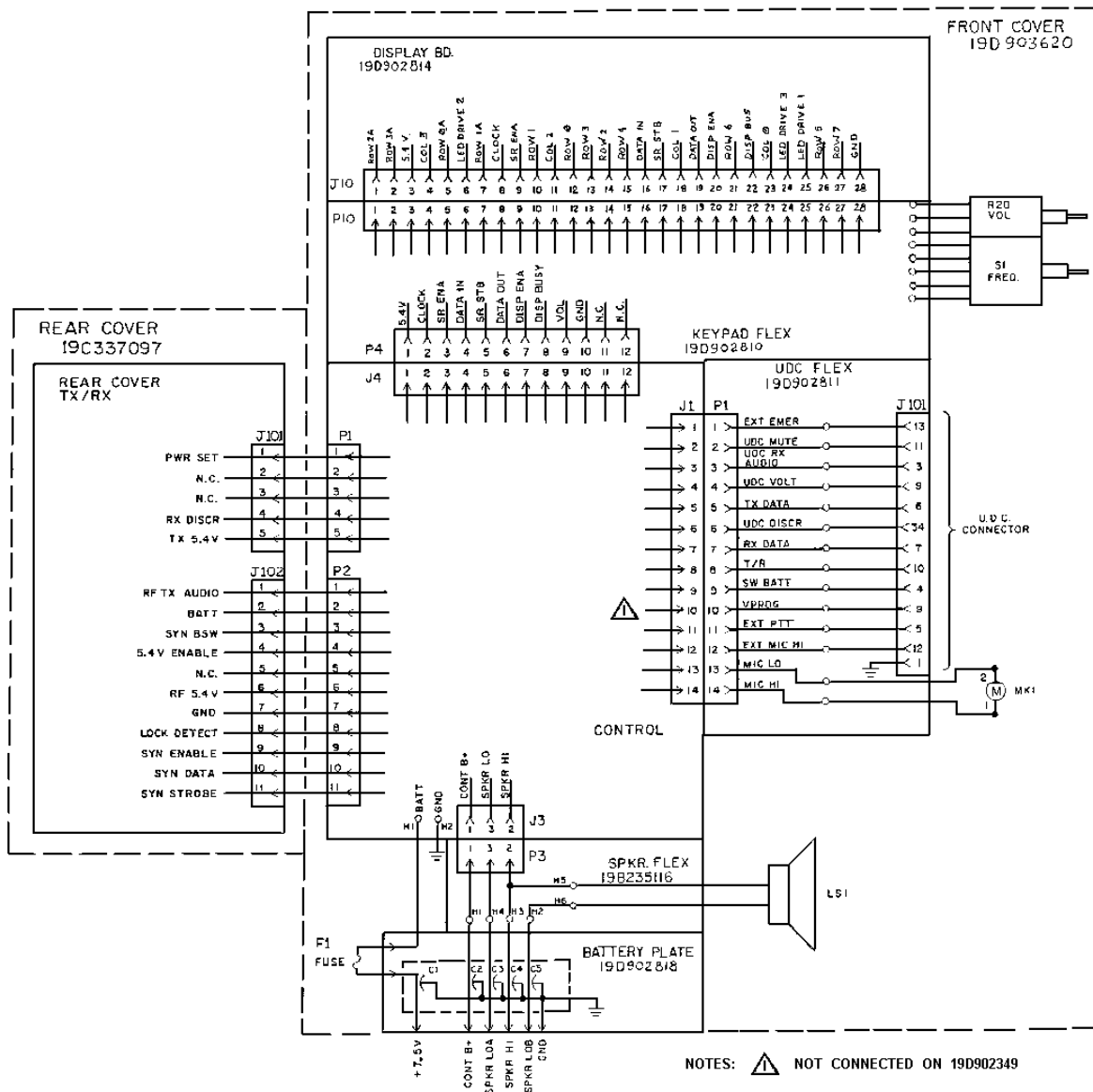

NOTES: ⚠ NOT CONNECTED ON 19D902349

STANDARD APPLICATIONS

(19D902383, Sh. 3, Rev. 0)



UDC CONTACT IDENTIFICATION
VIEWED FROM OUTSIDE OF CASE

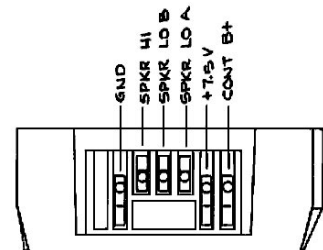

BATTERY CONTACT IDENTIFICATION
VIEWED FROM OUTSIDE OF CASE

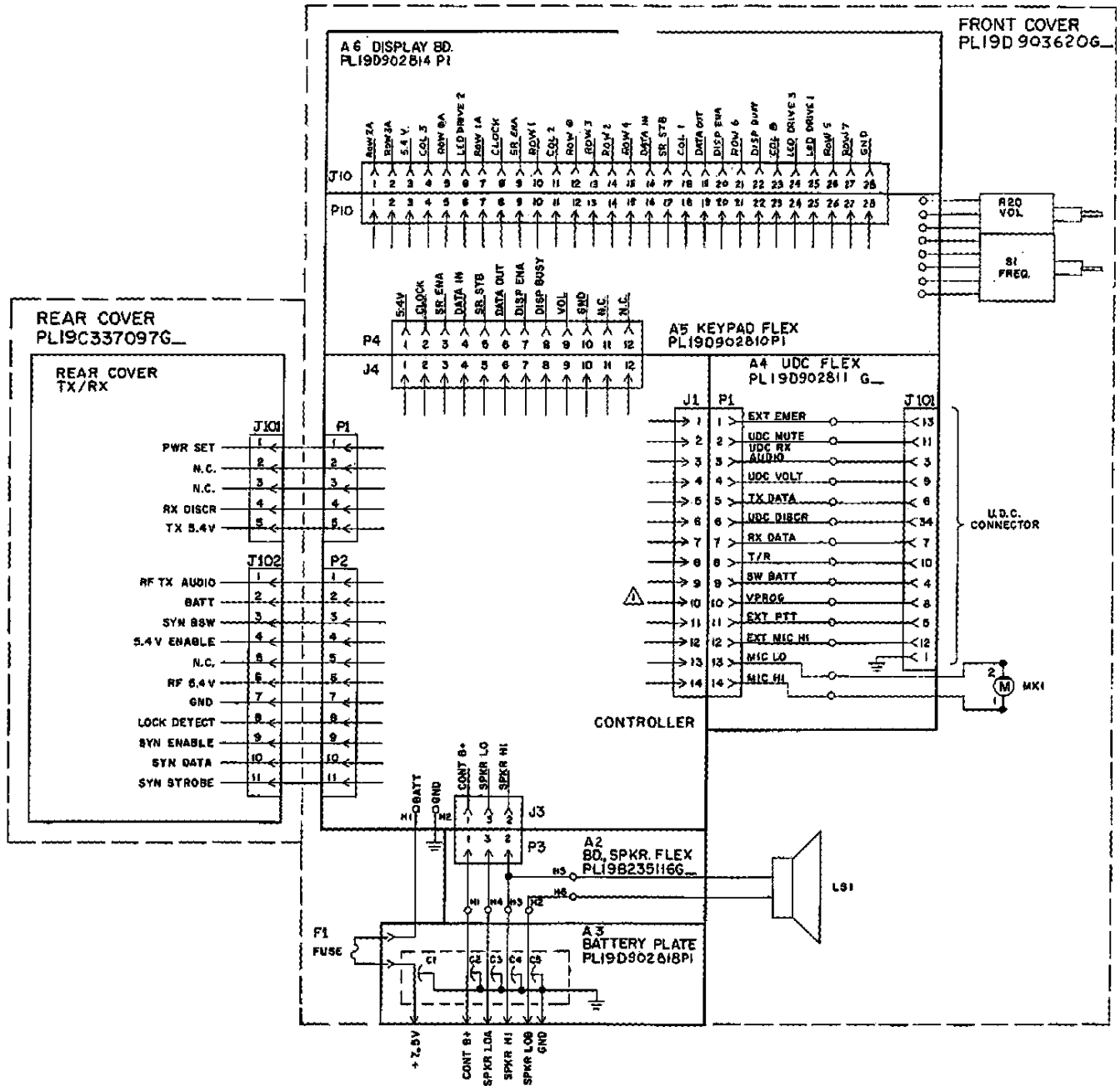

UDC CONTACT IDENTIFICATION
VIEWED FROM OUTSIDE OF CASE

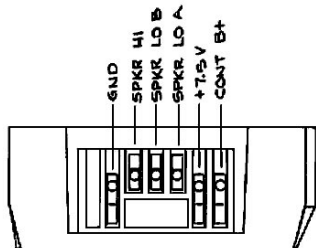

BATTERY CONTACT IDENTIFICATION
VIEWED FROM OUTSIDE OF CASE

AEGIS AND VOICE GUARD APPLICATIONS

(19D902383, Sh. 4, Rev. 0)

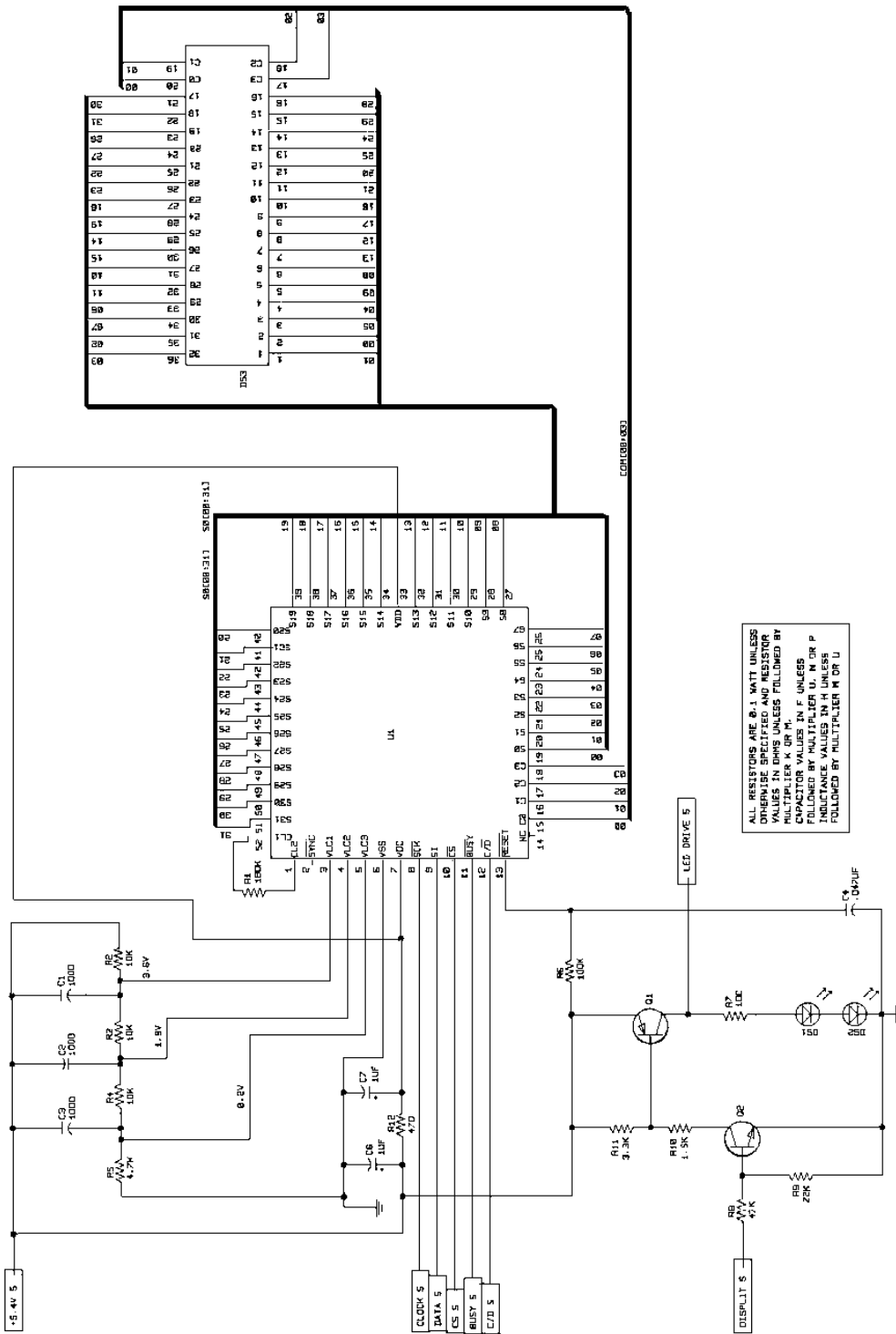

LCD BOARD
19D902814P1
Sheet 1 of 2

(19D902814, Sh. 4, Rev. 1)

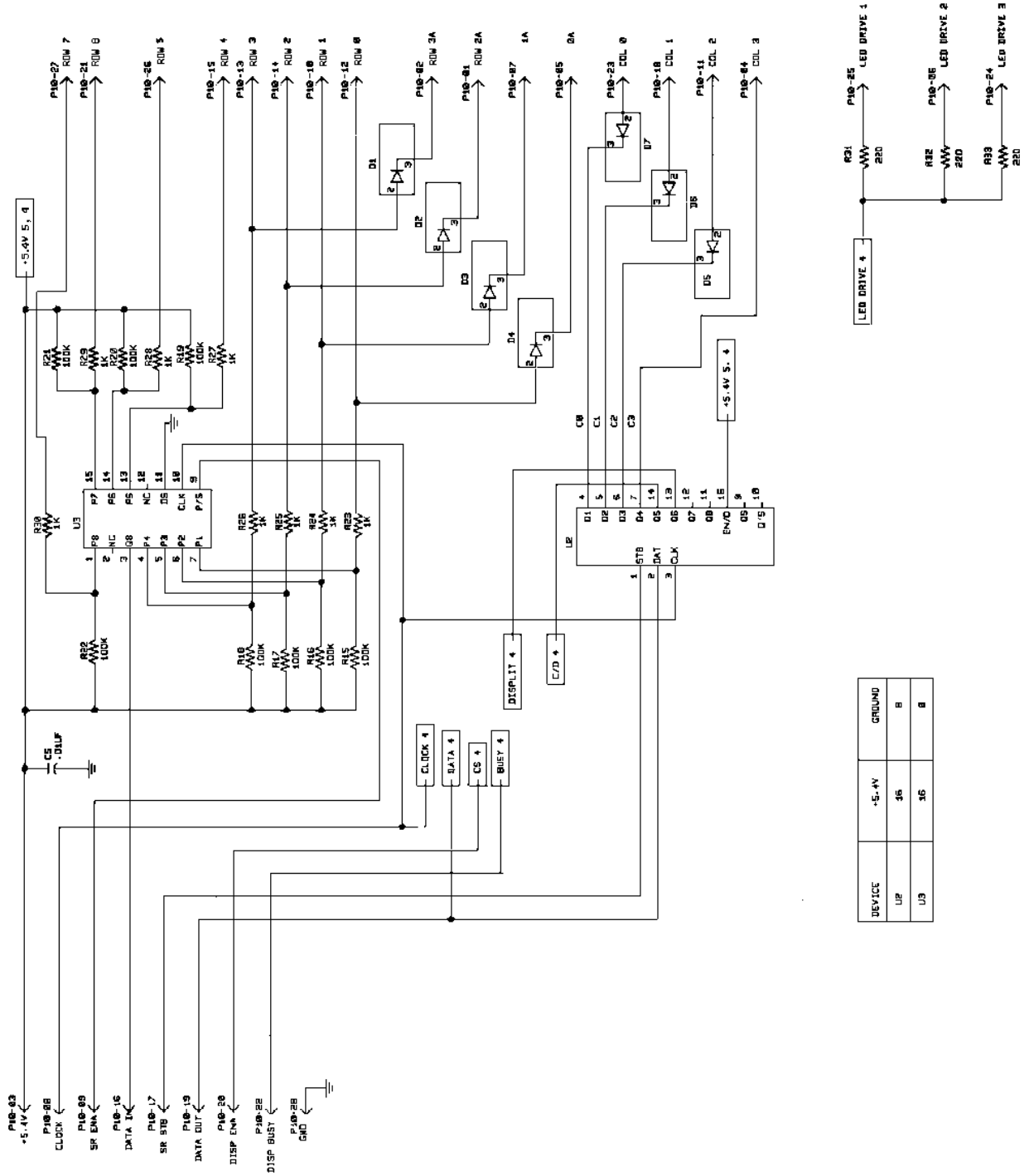

DEVICE	+5.4V	GROUND
U3	56	8
U3	56	8

LCD BOARD
19D902814P1
Sheet 2 of 2

(19D902814, Sh. 5, Rev. 1)

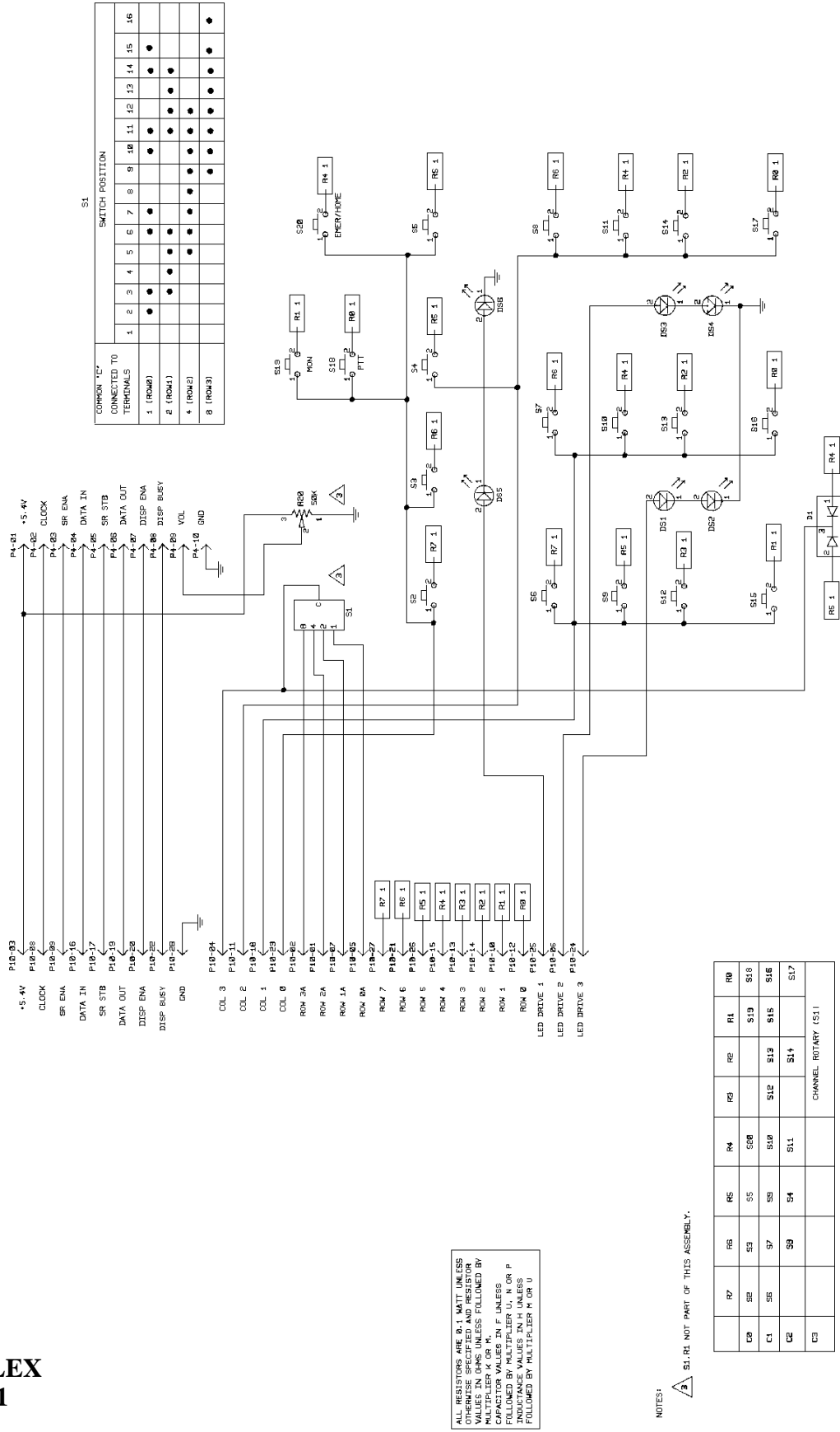

ALL RESISTORS ARE 0.1 WATT UNLESS OTHERWISE SPECIFIED AND RESISTOR VALUES ARE UNLESS FOLLOWED BY MULTIPLIER K OR M. CAPACITOR VALUES IN F UNLESS FOLLOWED BY MULTIPLIER U, N OR P. INDUCTANCE VALUES IN H UNLESS FOLLOWED BY MULTIPLIER R OR U.

NOTES: S1, R1 NOT PART OF THIS ASSEMBLY.

R7	R8	R5	R4	R3	R2	R1	R0
C0	S3	S5	S20	S19	S18	S17	S16
C1	S7	S9	S10	S12	S13	S15	S14
C2	S9	S4	S11	S14	S11	S17	
C3							CHANNEL ROTARY (S11)

**KEYPAD FLEX
19D902810P1**

(19D902810, Sh. 4, Rev. 3)