

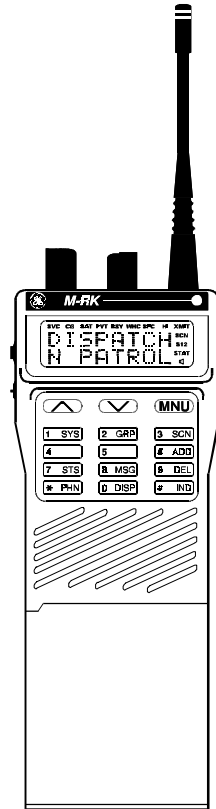

Mobile Communications



M-RK 896 - 941 MHz PERSONAL TWO-WAY FM RADIO COMBINATION

TABLE OF CONTENTS

Service Assemblies	LBI-38746
Service Section	LBI-38739
Disassembly and Assembly	LBI-38741

TABLE OF CONTENTS

DESCRIPTION	1
RADIO ASSEMBLY	4
TRANSMIT CIRCUIT	4
RECEIVE CIRCUIT	4
FREQUENCY SYNTHESIZER	4
LOGIC CIRCUIT	4
SYSTEM ANALYSIS	5
RADIO BOARD ASSEMBLY	5
Transmit Circuits	5
Power Amplifier Module (U7)	8
LPF/DC/TR SW Module (U8)	8
Receive Circuit	8
RF Amplifier/Mixer	8
First IF Amplifier	9
Second IF Amplifier/Discriminator (U11)	9
Synthesizer Circuit	9
Phase-Lock-Loop Module (U2)	9
Voltage-Controlled Oscillator (U5)	10
VCTCXO Reference Oscillator (Z1)	10
LOGIC CIRCUIT	10
Control Board Assembly	10
Microcomputer	10
Flash E ² PROM (U4)	10
RAM (U5)	10
E ² PROM (U6)	10
Digital Signal Processor (DSP)(U3)	11
Voltage Regulator (U9, U10)	11
Audio Amplifier (U11)	11
Audio Signal Processor (ASP)(U7)	11
LED Flex Assembly	11
LCD/KB Flex Assembly	11
Keypad	11
UDC	12
MAINTENANCE	12
INITIAL ADJUSTMENT	12
Transmit Circuit Alignment	12
Receive Circuit	12

TABLE OF CONTENTS (CONTINUED)

Synthesizer Circuit	12
PREVENTIVE MAINTENANCE	12
Antenna	12
Mechanical Inspection	12
Alignment	12
Frequency Check	12
DISASSEMBLY	13
REPLACEMENT	13
TROUBLESHOOTING PROCEDURE	13
WEATHERPROOF INTEGRITY	13
DIAGRAMS	
Figure 1 - M-RK I Controls and Accessories	2
Figure 2 - M-RK II Controls and Accessories	3
Figure 3 - Radio Block Diagram	5
Figure 4 - Logic Block Diagram (M-RK I)	6
Figure 5 - Logic Block Diagram (M-RK II)	7
Figure 6 - Power Amplifier (PA)	8
Figure 7 - LPF/ DC/ T/R SW. Module (U8)	8
Figure 8 - RF Amplifier/Mixer	8
Figure 9 - First IF Amplifier	9
Figure 10 - Second IF Amplifier/Discriminator	9
Figure 11 - Synthesizer	9

SPECIFICATIONS**SYSTEM**

FCC Identification Number	AXATR-204-A	
Frequency Range		
Transmit :	896 - 902 MHz	935 - 941 MHz
Receive :	935 - 941 MHz	
Frequency Stability	1.5 ppm	
Input Voltage	7.5 Vdc (nominal)	
Battery Life		
High Capacity	6.5 hours at 5-5-90 duty cycle	

SPECIFICATIONS

(Continued)

Dimensions (HxWxD)(M-RKII) (with high capacity battery)	176.8x68x40.6 mm (7x2.7x1.6 inches)
Weight (M-RKII) (with high capacity battery)	20.3 ounces
Operable Temperature Range	-30° to +60°C (-22° to +140°F)
TRANSMIT	
RF Power Output	0.5 to 3 watts
Spurious Emissions	-55dBc
Maximum Deviation	±2.5KHz
FM Hum & Noise	-45 dB
Audio Distortion	3% (60% Modulation)
Frequency Stability	1.5 ppm (-30°C to +60°C)
RF Load Impedance	50 ohms
Microphone Sensitivity	Less than 90 dB SPL (EIA 60% MOD)
Maximum Attack Time	25 milliseconds (PTT Pushed)
Audio Frequency Response	Within +1 and -3 dB of a 6 dB/octave pre-emphasis from 300 Hz to 3000 Hz.
RECEIVE	
Sensitivity (12 dB SINAD)	-116 dBm
Spurious Emissions	-57 dBm
Spurious Response	72 dB (minimum)
Selectivity	70 dB (25 KHz)
Squelch Sensitivity	6 dB SINAD
Distortion (EIA 0.5 watt)	5%
Audio Frequency Response	Within +1 and -3 dB of a 6 dB/octave de-emphasis from 300 Hz to 3000 Hz.

DESCRIPTION

The ERICSSON GE M-RK Personal Radio is a high-quality, high-performance FM radio. The radio is synthesized and operates in both trunked and conventional communication systems. The trunked mode allows selection of either a communications group or an individual radio within a system. Both the selected group and the individual radio are secured through digital signaling.

In the conventional mode, the user selects a channel and directly communicates on that channel. A channel is a transmit/receive radio frequency pair.

A group consists of several users with a common group identification (ID). A radio may have several groups, but the selected group determines who the unit can call at any specific time. In the trunked mode, a set of groups which communicate on a set of channels is called a system. In the conventional mode, a system is a set of channels. A system may consist of all trunking groups and channels, all conventional channels, or a mixture of both.

The M-RK Personal Radio is designed to operate in a M-RK Digital Trunking System or as a conventional radio providing the following features.

In trunked mode :

- Programmable Multiple System Capability -- The radio can operate on different trunked sites or on different systems at the same site.
- Multiple Group Capability -- The radio can communicate on several Groups within one trunked system.
- Group Call -- The M-RK has the capability of simultaneously calling all units within a group.
- Programmable Carrier Control Timer -- Personality information includes an optional period of transmit time from 15 to 120 seconds. After the timer expires, the unit will automatically unkey and provide an alert tone. This feature is re-initiated on every PTT and the alert tone is removed upon release of the PTT.
- Minimum Volume Level -- Personality information includes a minimum volume level.
- Programmable Squelch -- The noise squelch opening threshold can be programmed for each channel.
- Receive Mode Lock Out -- In normal trunked operation, the radio will not transmit while in the receive mode.
- Automatic Power Levels -- The desired power level on each channel can be programmed into the radio

personality. Power level is automatically selected dependent on the channel.

- Emergency Feature -- An emergency group can be programmed into the radio. This group is selected by pressing the EMR button. This allows a user to quickly reach this group and initiate the M-RK emergency signalling.
- Simple Remote Control Capability -- A speaker/microphone (which can also control PTT and the volume level) can be connected through the UDC (Universal Device Connector).
- Surveillance Feature -- The display backlighting may be programmed on or off per group. The side-tone beep, related to the operation of the radio controls, is also capable of being disabled on a group-by-group basis.
- Programmable through UDC -- The entire personality of the radio is programmed through four connections of the UDC.
- 16 Character Dot Matrix Alphanumeric Crystal Display -- This display is used to exhibit the condition of the radio. It shows channel designation, Channel Guard or Digital Channel Guard on/off, transmit mode, volume level, battery condition, channel busy, and high/low power output.

In conventional mode :

- 16/128-Channel Capability -- Channel designation can be a mixture of numerics (0-128) and alphanumerics displayed through the LCD. Channel control can come from the channel rotary switch, the emergency channel feature, or the front keypad.
- Programmable Multi-Tone Channel Guard (CTCSS) Encode/Decode -- Channel Guard tone frequencies within the range of 67 Hz to 210.7 Hz, including all of the standard EIA frequencies, may be programmed. Different encode/decode, encode only, and with/without Channel Guard frequencies are also programmable into the radio.
- Programmable Multi-Code Digital Channel Guard (CDCSS) Encode/Decode -- Similar capability as with Tone Channel Guard is provided.
- Programmable Talkaround Capability -- The ability to switch the transmit frequency from a repeater frequency to a direct communications frequency.
- Channel-Busy Lock Out -- Personality information includes the capability to prevent the transmitter from operating on a channel where carrier activity is present. The channel busy indicator (BSY) is active during this time.

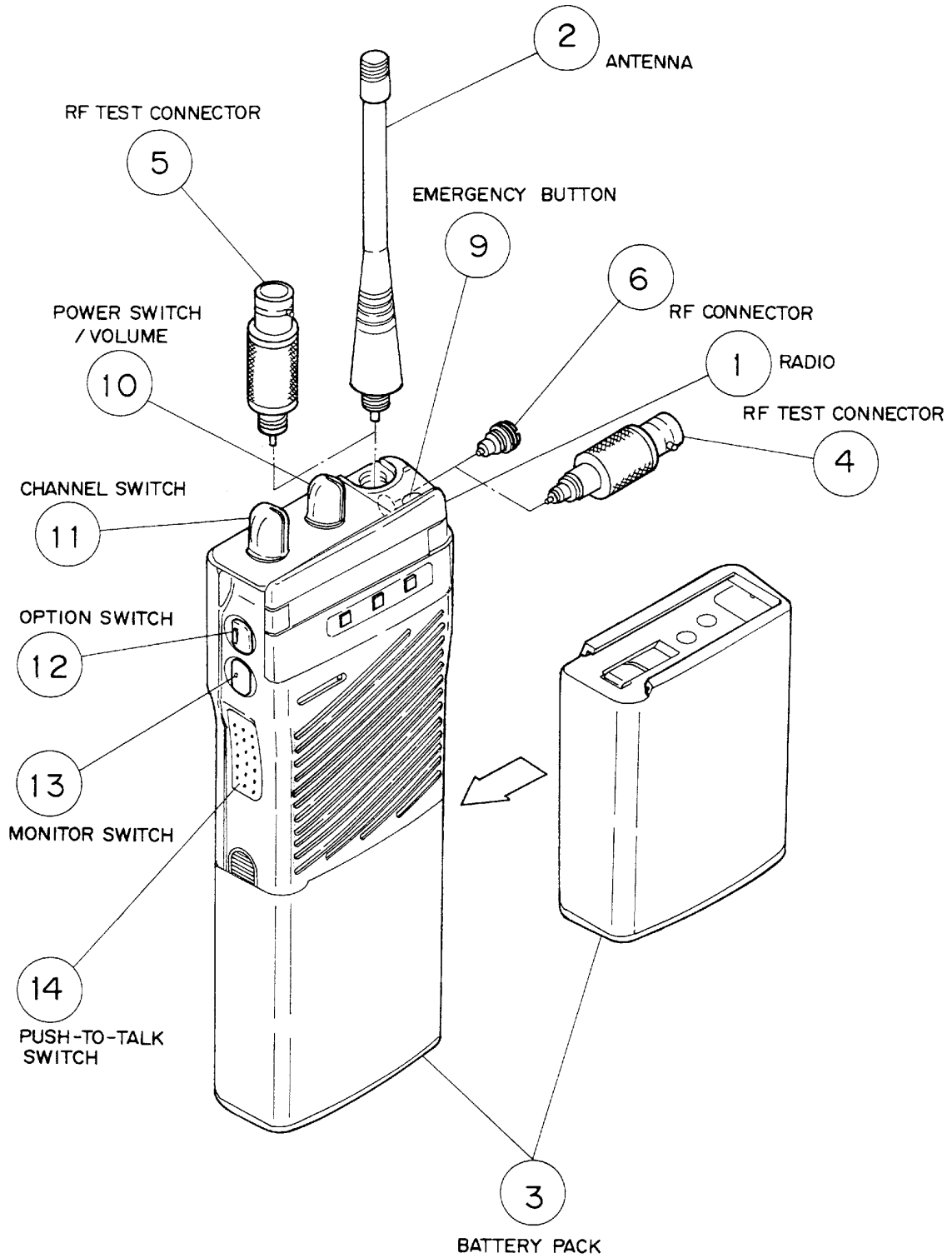

Figure 1 - M-RK I Controls and Accessories

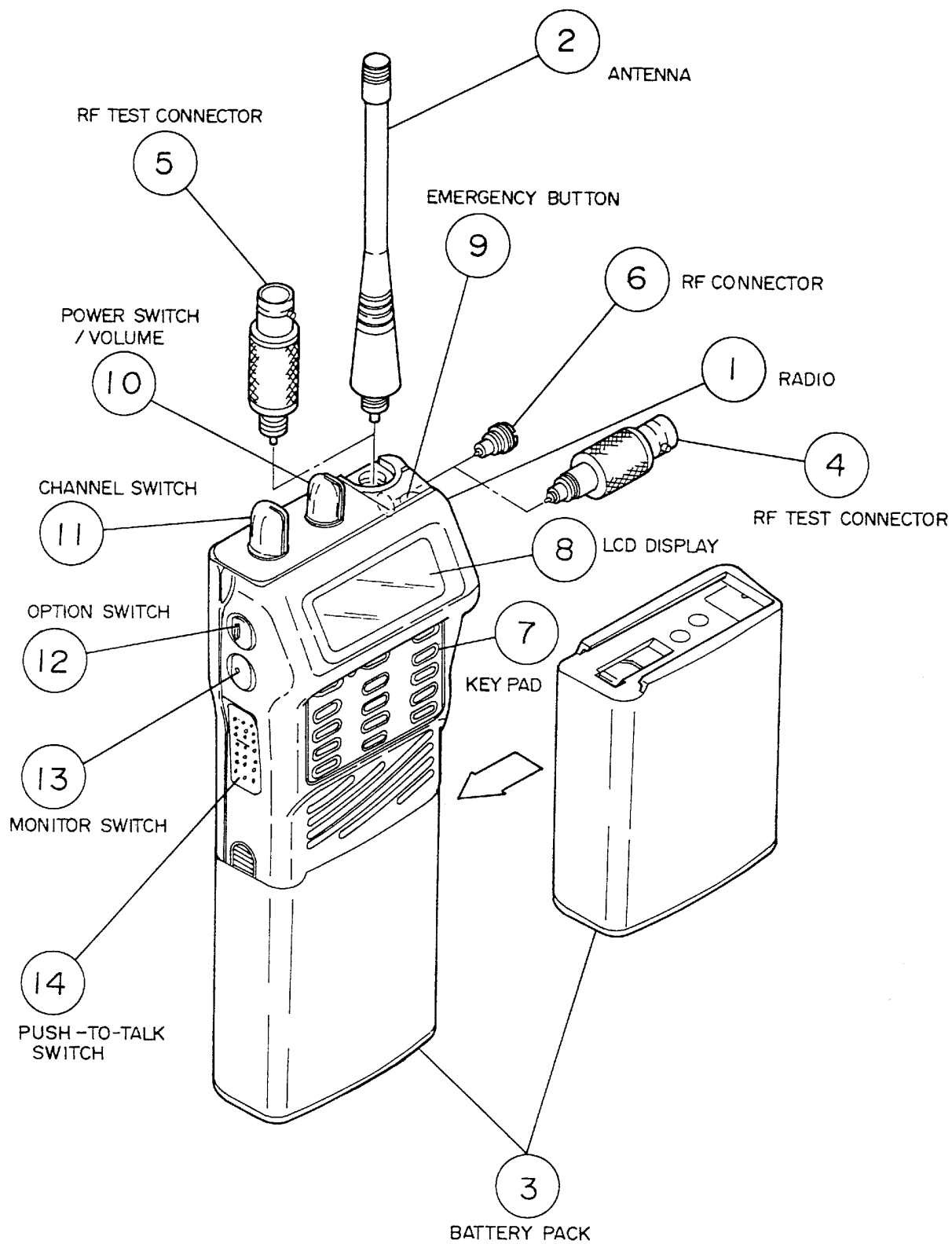

Figure 2 - M-RK II Controls and Accessories

Physically an M-RK radio consists of three main printed wire board assemblies and a battery pack as follows :

- a. A printed wire board specially shielded with zinc alloy on which the radio assembly (transmit/receive/synthesizer) is assembled.
- b. A Control board containing the microprocessor.
- c. A LCD/KB Flex wire board with display processor, rotary switch, AF volume with switch.
- d. A battery pack that fits the M-RK main unit.
- e. Lightweight plastic front and back housing.

RADIO ASSEMBLY

TRANSMIT CIRCUIT

The transmit circuit consists of four major circuits as follows :

- a. Wide Band Multiplier -- Multiplies the signal from the frequency synthesizer.
- b. Wide Band Power Amplifier -- Amplifies the output signal of the multiplier to the desired output level for transmission (a gain of 36.5 dB).
- c. Wide Band Power Control Circuits -- Can reduce the transmitter output level by 10 dB.
- d. LPF, DC, Switch Hybrid Module -- Consists of LPF and directional coupler and Tx/Rx switch.

The transmitter completely covers the band within the split. No adjustments are needed except for the RF power control voltage from the controller.

RECEIVE CIRCUIT

The receiver consists of three major circuits as follows :

- a. Front-End Circuit -- Consists of a one stage pre-amplifier (with band-pass filters).
- b. First Mixer and IF circuit -- A special double balanced mixer is used to convert the incoming signal to 55.025 MHz first IF. This is put through a band-pass filter (BPF) and an IF amplifier to get the desired first IF signal.

- c. Second IF (455 KHz) -- Consists of one IC and three BPF containing the second mixer, the second IF amplifier, and the FM detector. The second IF output provides the Logic section with audio output.

FREQUENCY SYNTHESIZER

The frequency synthesizer is made up of three major modules as follows :

- a. VCO Module -- The 900 MHz band frequency synthesizer has one common VCO (450 MHz) for both transmitting and receiving. The transmitter is modulated at both the VCO and the VCTCXO.
- b. VCTCXO Module -- The VCTCXO is a voltage controlled, temperature compensated crystal oscillator providing 13.2 MHz as a reference frequency with modulation capability.
- c. Phase-Lock Loop -- Consists of a frequency divider and a low current drain CMOS IC for phase comparison.

LOGIC CIRCUIT

The logic circuit consists of a control board assembly with an audio processor and a LCD/KB Flex assembly as follows :

- a. Control Board Assembly -- Carries two microprocessors, RAM, Flash E²PROM, audio processor, digital processor and I/O interconnections with the frequency synthesizer. This board commands all the functions and operation of the M-RK radio.
- b. Audio Signal Processor (ASP) -- Includes transmitter and receiver audio circuits.
- c. Digital Signal Processor (DSP) -- Includes a modem, address decoder, and clock control circuit.
- d. LCD/KB Flex Assembly -- Includes LCD driver and processor for the display and rotary switch and AF volume with ON/OFF switch.

SYSTEM ANALYSIS

Refer to Figures 3, 4 and 5. The M-RK radio consists of three printed wire boards as follows :

- Radio Board Assembly -- carries the transmit, receive, and frequency synthesizer circuits.
- Control Board Assembly -- supports logic control circuits.
- LED Flex Assembly carries LEDs (M-RK I).
- LCD/KB Flex Assembly -- carries LCD (M-RK II).

Interconnection of the control board with other boards and control circuits is made with flexible circuit boards and connectors.

Circuit illustrations shown are simplified representatives of actual circuits.

They are intended only to illustrate basic circuit functions.

RADIO BOARD ASSEMBLY

Transmit Circuits

The M-RK transmit circuit, as shown in Figures 6 and 7, consists of the following integrated circuit, modules.

- Power Amplifier (PA)
- LPF/DC/TR SW

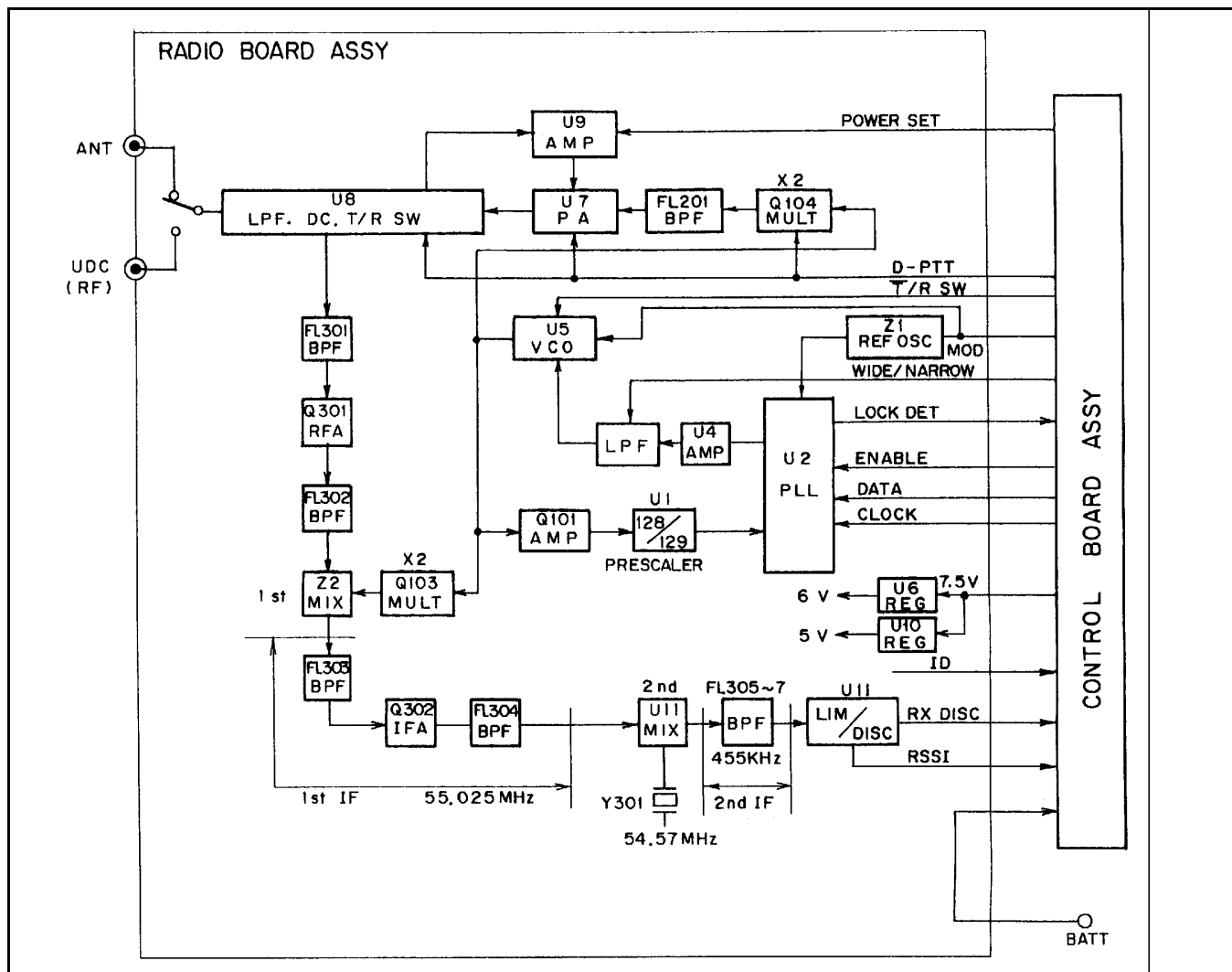

Figure 3 - Radio Block Diagram

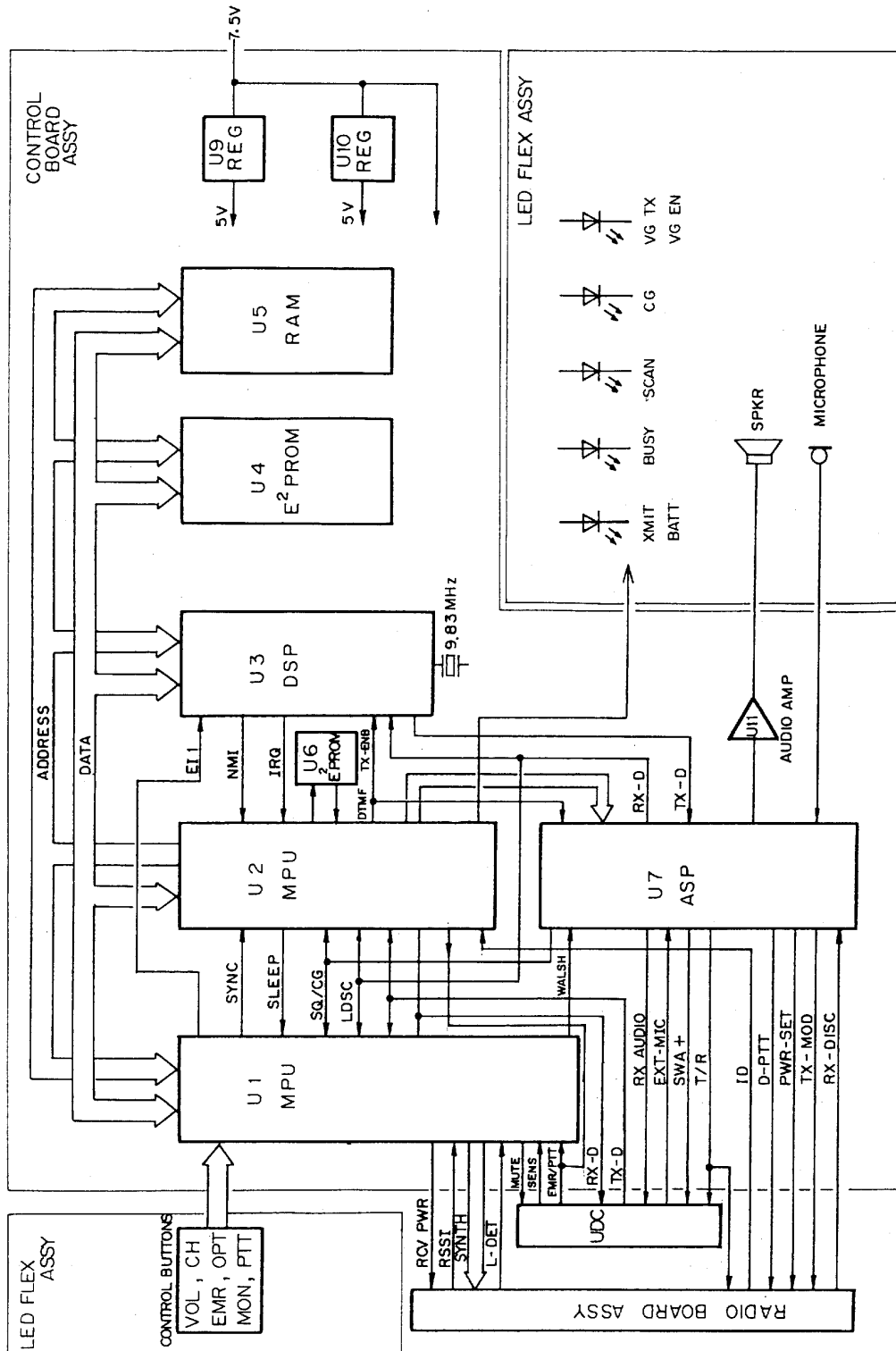

Figure 4 - Logic Block Diagram (M-RK I)

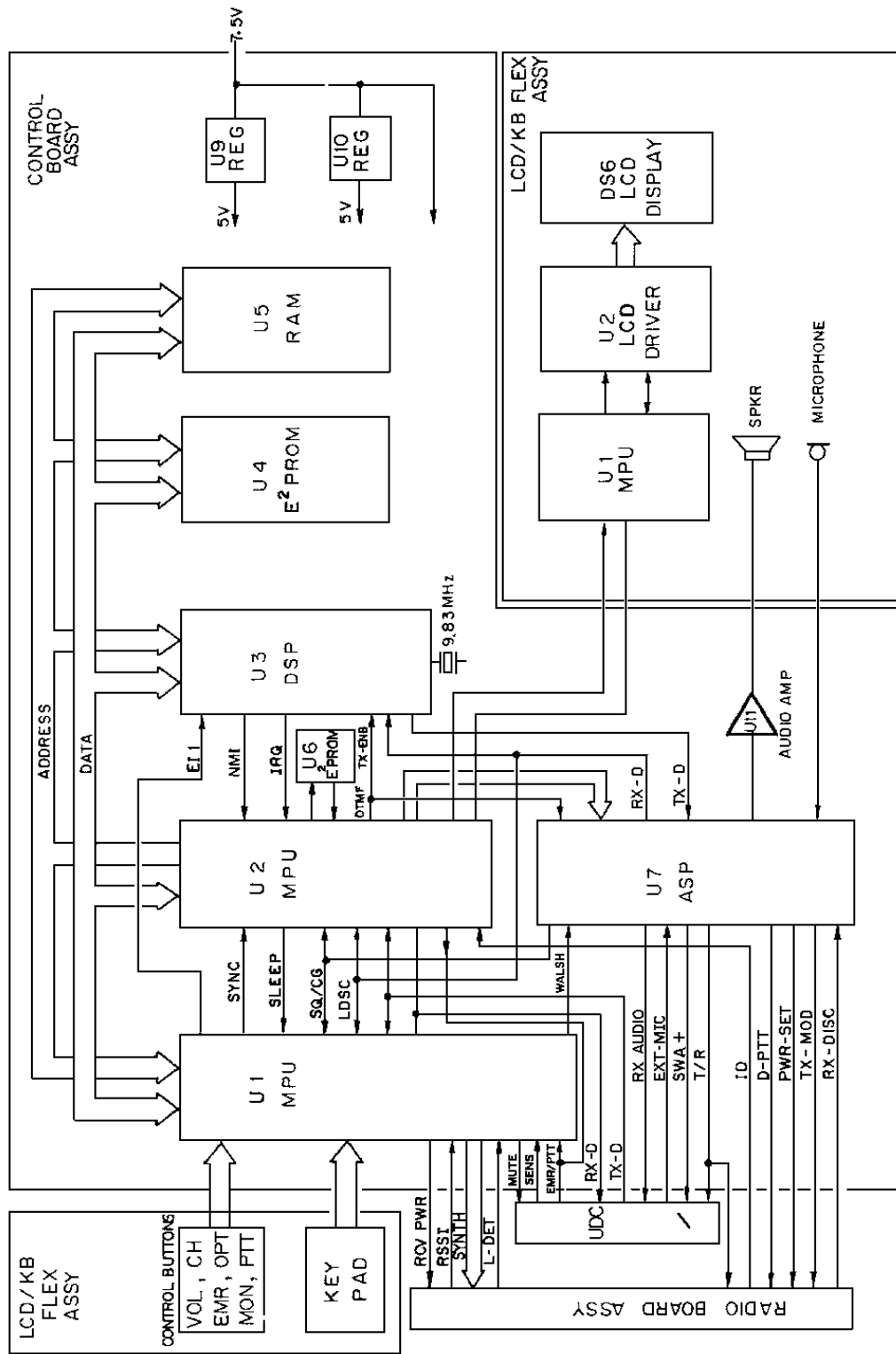

Figure 5 - Logic Block Diagram (M-RK II)

Power Amplifier Module (U7)

Power Amplifier (PA) U7 is a five-stage, wideband amplifier module with an input and an output impedance of 50 ohms (Figure 6). The first stage of the PA module has the dc power supplied by power set transistor Q203. The RF power output from multiplier is connected through a HPF to pin 1 of the PA module where it is applied to the input of the RF power amplifier stages. The RF power amplifier stages amplify the input from the Tx-Amp module to a typical power output level of 4.5 watts at pin 5. The output at pin 5 is connected through the HPF and LPF/DC/SW module. A minimum power level of three watts is on the output of the LPF/DC/SW module.

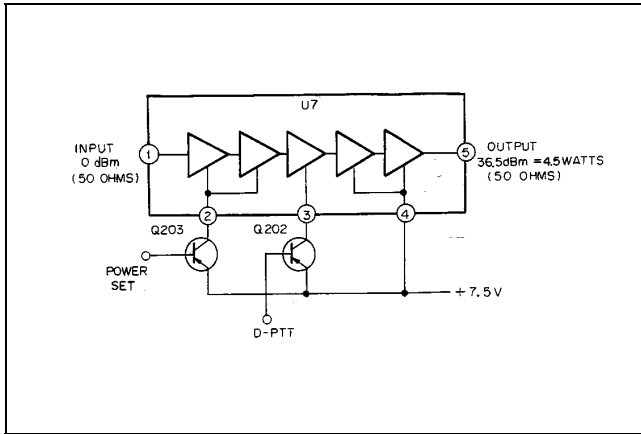

Figure 6 - Power Amplifier (PA)

LPF/DC/TR SW Module (U8)

The output of the PA module is connected LPF/DC/SW through HPF. The FN network is a passive LC low-pass filter with an insertion loss of less than 1.4 dB in the pass-band. It also has a rejection greater than 35 dB in the stop band. The output of the FN connected to the system antenna or to the UDC connector.

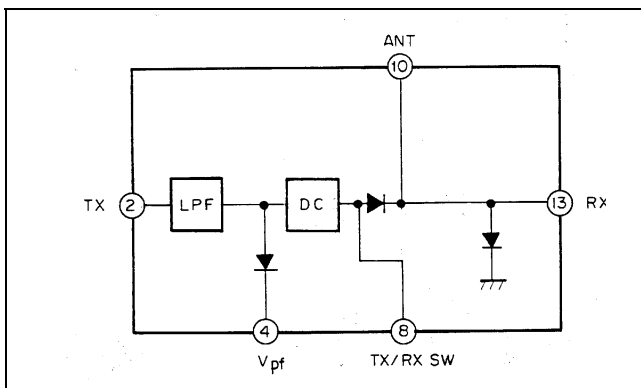

Figure 7 - LPF DC T/R SW. Module (U8)

Receive Circuit

The M-RK receive circuit, as shown in Figures 8, 9 and 10, consists of the following circuits :

- RF Amplifier/Mixer
- First IF Amplifier
- Second IF Amplifier/Discriminator

RF Amplifier/Mixer

The RF Amplifier/Mixer circuit (Figure 8) contains two third-order band-pass filters (FL301 and FL302), and RF amplifier circuit (Q301) and a double-balanced diode mixer circuit (Z2). RF from the antenna or UDC connector is coupled through LPF/DC/TR SW module to the input of the RF amplifier circuit. The RF signal on the input of the RF amplifier is first coupled through band-pass filter FL301 to the input of grounded emitter broad-band RF amplifier transistor Q301. This amplifier provides 13 dB of power gain to reduce thermal noise. The output of the RF amplifier is coupled through band-pass filter FL302 to drive double balanced mixer circuit Z2.

The RF signal from the RF amplifier and the injection frequency from the synthesizer circuit, provide a 55.025 MHZ IF on the output of the mixer. The double-balanced Mixer has a typical conversion loss of 7.5 dB between the RF input and IF output. All inputs and the output of the RF Amplifier/Mixer have 50 ohms matching impedance. The +7 dBm injection frequency level, provided by the synthesizer and amplifier circuit transistor Q103, is connected to the injection frequency input. The output of the Mixer circuit is connected to the input of the first IF Amplifier.

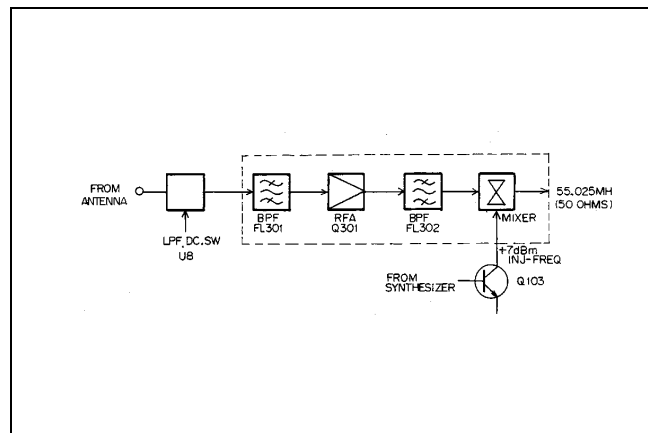

Figure 8 - RF Amplifier/Mixer

First IF Amplifier

The first IF amplifier contains an amplifier circuit and two crystal filters of two poles, respectively (refer to Figure 9). The first IF signal (55.025 MHz) connects to the input of preamplifier transistor Q302 through pre-crystal filter FL303 with an impedance of approximately 3 Kohms. Preamplifier Q302 provides a 23 dB power gain. The output is connected to the input of IF amplifier IC U11 through crystal filter FL304.

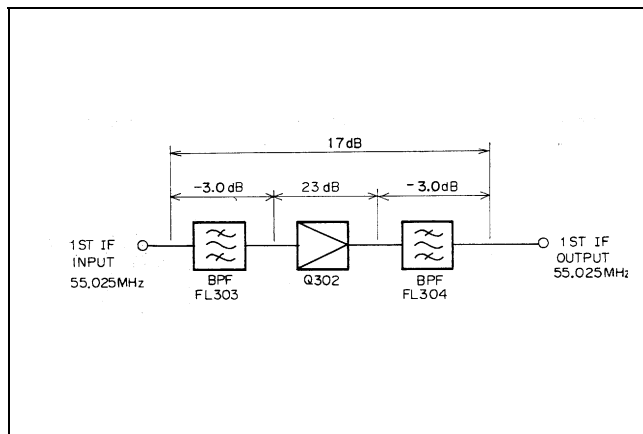

Figure 9 - First IF Amplifier

Second IF Amplifier/Discriminator (U11)

The Second IF Amplifier/Discriminator circuit (Figure 10) contains FM IF IC U11 (TA31132F) and 455 KHz ceramic filter FL305, FL306, FL307. The FM IF IC contains a local oscillator, mixer, IF amplifier, FM detector, and an audio amplifier. The 55.025 MHz IF output from the first IF amplifier is connected to the input of second IF amplifier U11 pin 21 of TA31132F and converted to the second IF frequency (455 KHz). The second IF output is connected to pin 7 input of TA31132F through the 455 KHz ceramic fil-

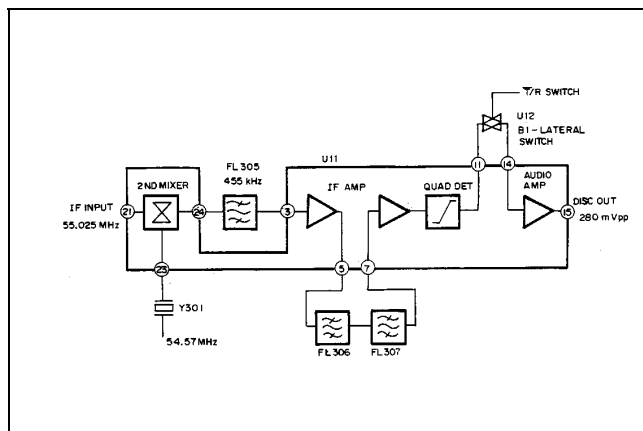

Figure 10 - Second IF Amplifier/Discriminator

ter to the IF amplifier and FM detector circuits. The recovered audio from the FM IF IC is connected to J1-3B.

Synthesizer Circuit

The Synthesizer circuit (Figure 11) contains Phase-Lock-Loop (PLL) module U2, VCTCXO Reference Oscillator module Z1, TX/RX Voltage Controlled Oscillator (VCO) module U5, and a Low-Pass-Filter (LPF) amplifier. The VCO used to generate the receive and transmit frequencies is locked to a stable VCTCXO reference oscillator through a PLL. This feed-back loop divides the VCO frequency down to a signal in the range of 3.5 MHz. This signal is divided with a programmable divider to 6.25 KHz, and generates a VCO control signal by comparing the 6.25 KHz feedback with a 6.25 KHz signal derived by dividing a 13.2 MHz VCTCXO by 2112. As the least-significant bit in the programming is changed, the VCO is forced to change by 6.25 KHz.

The synthesizer circuitry is contained on two modules, the VCO module U5 and the VCTCXO reference oscillator module Z1.

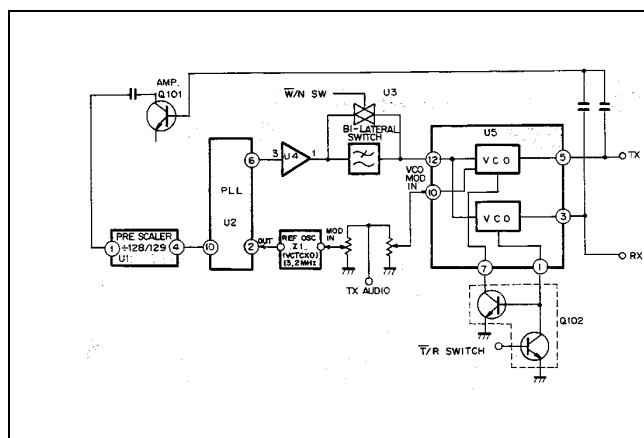

Figure 11 - Synthesizer

Phase-Lock-Loop Module (U2)

The PLL module U2 contains a reference frequency, divider, phase detector, and a programmable divider. The phase detector dc voltage output signal is filtered with a passive low-pass filter followed by a 6.25 KHz filter to reduce the level of reference modulation on the VCO. This dc output represents the error between the VCO frequency (phase) and the reference (VCTCXO) and is applied to the VCO on frequency. A lock-detect output is developed from pin 9 of U2. The output is "AND"ed with the TX-PTT output from the microcomputer to prevent transmission before the VCO is on frequency.

Serial data from the microcomputer is shifted into the PLL to set the division parameter which establishes the frequency. A clock signal is provided on another input and the data is latched with the enable input.

Voltage-Controlled Oscillator (U5)

The VCO uses a low-noise, high-gain transistor as the basic oscillator. The resonant circuit, which determines the frequency of oscillation, is formed by a high-Q SAW which is used to set the center frequency at the factory. The output of the VCO is coupled into a cascade amplifier which produces 0 dBm. The output of the RX-VCO amplifier is coupled into the receive first double-balanced mixer circuit Z2 through multiplier Q103. The VCO amplifier output is also connected to the input of TX-multiplier transistor Q104.

VCTCXO Reference Oscillator (Z1)

The Z1 oscillator module is self contained, fully temperature compensated and operates at a frequency of 13.2 MHz. The oscillator also has modulation capability. Frequency is adjusted by a trimmer while monitoring the transmit circuit output at the antenna jack.

LOGIC CIRCUIT

The logic circuit consists of control circuits and audio circuits (Figures 4 and 5).

Physically, this circuit consists of two circuit board as follows :

- Control Board Assembly
- LED Flex Assembly (M-RK I)
- LCD/KB Flex Assembly (M-RK II)

Control Board Assembly

The Control board consists of the following circuits (refer to Figures 4 and 5) :

- CMOS Microprocessor (U1, U2)
- E²PROM (U6)
- Flash E²PROM (U4)
- Custom CMOS DSP Chip (U3)
- Custom CMOS ASP Chip (U7)
- CMOS Inverters (U12)
- CMOS OR gates (U15)
- CMOS SRAM (U5)

- Audio Amplifier (U11)
- 5 volt Regulator (U9,10)

Microcomputer

The main microcomputer circuit in this radio consists of microprocessor, HD6475328FI10 (U2), 2 Kx8E²PROM (U6), 128 K x 8 Flash EPROM (U4), 8 K x 8 RAM (U5), and custom DSP (U3). This circuitry runs at a 9.8304 MHz rate determined by crystal Y1 and controls the radio through a second microprocessor HD6473308FI6 (U1). This microprocessor (U1) runs at an 4.9152 MHz rate. The 4.9152 MHz rate is determined by DSP (U3).

- Controlling the DSP, Flash E²PROM and RAM
- Loading data to the frequency synthesizer
- Fetching and processing the PTT, monitor, channel selection, and volume control.
- Controlling the LED display (M-RK I).
- Loading data to the LCD display processor (M-RK II).
- Controlling the audio circuit (processor)
- Decoding the squelch
- Encoding/Decoding the Channel Guard and Digital Channel Guard
- Controlling the loading interface for the radio data (channel number and signaling)

Flash E²PROM (U4)

IC U4 contains the software to control the microprocessor.

RAM (U5)

This RAM has a storage capacity of 8 Kbits x 8.

E²PROM (U6)

This E²PROM has a storage capacity of 2 Kbit x 8. This personality controls various functions of the radio. The personality data is entered from outside the radio through the UDC connector to the microprocessor and then to the E²PROM. The data mainly consists of the following :

- Channel Frequency Data
- CG/DCG data
- TX Power, TX Modulation Data
- Squelch Data

- Display Data, etc.

Digital Signal Processor (DSP)(U3)

The primary purpose of this DSP is to off-load the host microprocessor so that the host can spend as much time as possible in a low power state. This chip has the functions as follows :

- MODEM
- FIFO
- Watch Dog Timer
- Clock Control
- Control Register Bank
- Interrupt Control
- Address Decode

Voltage Regulator (U9, U10)

Voltage regulator U9, U10, Q1 generate 5 VDC for Control Board and LCD/KB Flex Board.

Audio Amplifier (U11)

The audio amplifier is located between the audio processor and the speaker. Amplifier U11 amplifies the output signal of the ASP (U7) to the level adequate for driving the speaker and UDC audio output.

Audio Signal Processor (ASP)(U7)

The Audio processor consists of a one-chip IC accommodating almost all the audio functions. The audio functions are under control of the microcomputer in compliance with the function of the radio unit. The functions of the audio processor are as follows :

- Rx Audio process with Tone Reject Filter, De-Emphasis and Programable Attenuater.
- Data limiting
- CG/DCG filtering and limiting
- Noise Squelch filtering and detecting
- 8 bits D/A Converter with sample and hold
- Tx audio process with Mic Amplifier, Pre-Emphasis, Deviation Limiter, Summing Amplifier, Post Limiter Filter and Programable Attenuater.
- Data signal filtering

- Two 6 bits Programable Divider for clock and alert tone.

All these functions are made up of switched capacitor filters, amplifiers, and timing logic. The timing for this logic is derived from the 4.9152 MHz clock generator (DSP).

LED Flex Assembly (M-RK I)

The LED Flex board composed of the following items:

- LED (DS1, DS2, DS3)
- Volume Control with ON/OFF Switch (R8)
- Channel Select Switch (S1)
- Microphone (MK1)
- Speaker (LS1)

LCD/KB Flex Assembly (M-RK II)

The LCD/KB Flex board composed of the following items :

- Display Processor (U1)
- LCD Drive IC (U2)
- LCD (DS6)
- Backlighting Circuit (Q1 and DS1 - DS5)
- Volume Control with ON/OFF Switch (R8)
- Channel Select Switch (S1)
- Microphone (MK1)
- Speaker (LS1)

The LCD driver converts data from the Display processor into a signal which can drive the LCD display. The LCD display is equipped with 16 character dot matrix and 15 ICONs. Microprocessor signals drive LCD driver which turns the LCD on. Also, this board has a backlighting circuit.

Keypad (M-RK II)

There are 15 buttons of key switches (keypads) on the System model M-RK II. The keypads consist of flexible cable and rubber contacts, and each connect through cable to the microcomputer.

UDC

The UDC (located on the side of the radio housing) allows various kinds of external equipment connections to be made. External equipment connecting signals are as follows:

- EXT MIC IN
- 12V IN
- AUDIO OUT
- SWA + OUT
- UDC SENS IN
- $\overline{T/R}$ OUT
- $\overline{EXT EMR}$ IN
- \overline{MUTE} OUT
- $\overline{EXT PTT}$ IN
- GND
- TX DATA IN
- RX DATA OUT

The radio control microprocessor senses the value of voltage at the UDC sens line and switched the appropriate audio circuits to provide proper radio/accessory operation. The UDC voltage is set by the resistor within the UDC.

MAINTENANCE

This Maintenance section provides information on adjustment of the radio (transmit, receive, and synthesizer), preventive maintenance and a disassembly procedure. Information is also provided for removing and replacing chip component and module replacement. The Service Section, listed in the table of contents, provides a more complete set of alignment procedures for the radio plus a detailed troubleshooting procedure.

INITIAL ADJUSTMENT

The M-RK radio personality is programmed using an IBM compatible personal computer and programming software. The procedure is described in the applicable programming manual.

After the radio personality has been programmed, the following adjustments should be made by a qualified electronics technician.

Transmit Circuit Alignment

The transmit circuit is factory turned and should not require any readjustment. The frequency and modulation should be measured and recorded for future reference.

Receive Circuit

No initial adjustments to the receive circuit are required.

Synthesizer Circuit

No initial adjustments to the synthesizer are required.

PREVENTIVE MAINTENANCE

To ensure a high operating efficiency and to prevent mechanical and electrical failures, routine checks should be performed on all mechanical and electrical parts at regular intervals. Preventive maintenance should include the following checks.

Antenna

The antenna and antenna contact should be kept clean and free from dirt or corrosion. If the antenna or contact should become dirty or corroded, loss of radiation and a weak signal will result.

Mechanical Inspection

Since portable radio units are subject to shock and vibration, check, for loose plugs, nuts, screws and other parts to make sure that nothing is working loose.

Alignment

The transmit and receive circuit meter readings should be checked periodically and the alignment "touched up" when necessary. Refer to the applicable alignment procedure and troubleshooting sheet (found in the Service Section) for typical voltage readings.

Frequency Check

Check transmit frequency and deviation. Normally, these checks are made when the unit is first put into operation. They should be repeated after the first month of operation, then again one time each year.

DISASSEMBLY

Procedures to access the Radio Board Assembly (transmit, receive, and synthesizer circuits) or Control Board Assembly for servicing are explained in the following paragraphs.

CAUTION

Always remove the battery pack before removing any component board to avoid blowing the fuse.

- TORX screwdriver (T-8) 1
- Screwdriver (M2) 1
- Pencil type soldering iron (25-40 watts) with a fine tip. 1

REPLACEMENT

The major components of the M-RK Personal Radio are the PA, LPF/DC./T/R SW, VCO (Voltage-Controlled Oscillator), and the VCTCXO (Reference Oscillator). These are very reliable devices and will not normally need to be replaced. Before replacing any of these modules, always check out the associated circuitry carefully.

To remove any of these major components, refer to the applicated replacement procedure found in the Service Section.

TROUBLESHOOTING PROCEDURE

Maintenance of the M-RK Personal Radio is facilitated by using the Troubleshooting Procedures and service techniques unique to this radio. The Troubleshooting procedures are designed to quickly locate the defective component or circuit. These procedures are found in the Service Section.

WEATHERPROOF INTEGRITY

The M-RK radio is designed to meet MIL-810-D specification for blowing rain. All accesses to the M-RK radio are protected from water entry by suitable gaskets and seals. However, degradation due to use or disassembly during repairs, may affect the integrity of the seals as provided by factory assembly. A maintenance procedure is provided in the Service Section to assure that the radio housing will continue to meet the weatherproof features as designed.



Ericsson GE Mobile Communications Inc.
Mountain View Road • Lynchburg, Virginia 24502