

LBI-38839B

Installation Manual

**DUAL FORMAT
MDR™ MOBILE RADIO**



NOTICE!

This manual covers Ericsson and General Electric products manufactured and sold by Ericsson Inc.

NOTICE!

Repairs to this equipment should be made only by an authorized service technician or facility designated by the supplier. Any repairs, alterations or substitution of recommended parts made by the user to this equipment not approved by the manufacturer could void the user's authority to operate the equipment in addition to the manufacturer's warranty.

NOTICE!

The software contained in this device is copyrighted by Ericsson Inc. Unpublished rights are reserved under the copyright laws of the United States.

This manual is published by **Ericsson Inc.**, without any warranty. Improvements and changes to this manual necessitated by typographical errors, inaccuracies of current information, or improvements to programs and/or equipment, may be made by **Ericsson Inc.**, at any time and without notice. Such changes will be incorporated into new editions of this manual. No part of this manual may be reproduced or transmitted in any form or by any means, electronic or mechanical, including photocopying and recording, for any purpose, without the express written permission of **Ericsson Inc.**

TABLE OF CONTENTS

INTRODUCTION	5
UNPACKING AND CHECKING EQUIPMENT	5
PLANNING THE INSTALLATION	6
EQUIPMENT REQUIRED	8
INSTALLATION IN VEHICLES POWERED BY LIQUEFIED (LP) GAS	9
MOUNTING LOCATION	9
INSTALLATION	10
RUNNING CABLES	10
MOUNTING THE RADIO	13
POSITIVE LATCH HANDSET HOLDER WITH SWIVEL (KRY 105 044)	14
HANDSET	17
OPTION INSTALLATION	17
ANTENNA - OPTION PMAN1L	17
OPTION CABLE KIT - OPTION PMCD7Z	18
POWER CABLE - OPTION PMCD9A	20
NOISE SUPPRESSION KIT - OPTION PMPD1A	20
ALARM (HORN) RELAY KIT - OPTION PMSU1C	20
TALK-AROUND KIT - OPTION PMTA1B	21
EXTERNAL SPEAKER KIT - OPTION PMZM1K	22
HANDSET EXTENSION CABLE KIT - OPTION PMZM5V	23
OPTION INTERCONNECTION DIAGRAMS	24

This page intentionally left blank

INTRODUCTION

This manual contains installation instructions for the Dual Format MDR Mobile Radio and associated accessories. These instructions cover the mounting and cabling of the radio; interconnection and wiring diagrams are provided at the back of the manual for reference. Before installation, the radio should be programmed using an IBM compatible personal computer and the following items:

Serial Programming Interface Module Kit	TQ3370
Programming Cable	TQ3371
Dual Format MDR Programming Software	TQ3364
or	
Dual Format MDR Programming Software (GE-MARC only)	TQ3346

Refer to programming manual TQ3346 (included with TQ3364).

UNPACKING AND CHECKING EQUIPMENT

When ready for installation, carefully unpack the radio and identify each item in the shipping container as listed below. If damage has occurred to the equipment during shipment, file a claim with the carrier immediately. The available options for the Dual Format MDR Mobile Radio series are covered in Table 1.

<input type="checkbox"/> Dual Format MDR Mobile Radio	
<input type="checkbox"/> Handset	344A3783P2
<input type="checkbox"/> Handset cable (coiled), 6 feet stretched	19B802397P1
<input type="checkbox"/> Handset holder	KRY 105 044
<input type="checkbox"/> Power cable, 9 feet	19B801358P18
<input type="checkbox"/> Mounting bracket kit	19A138051G11
<input type="checkbox"/> Operator's Manual	LBI-38838
<input type="checkbox"/> Installation Manual	LBI-38839

Table 1 - MDR Optional Accessories

Option	Description	Part Number
PMAN1L	800 MHz roof mount antenna with TNC connector	19B209568P5
PMCC1H	Handset extension cable (no coil), 18 feet, requires option PMCN1A	19B801636P1
PMCC3S	Handset cable (coiled), 6 feet stretched	19D901619P4
PMCC9M	External speaker cable, 18 inches	19A149590P8
PMCD1W	External speaker cable, 16 feet, requires option PMZM1K	19A149590P10
PMCD7Z	External option cable, 2 feet	19C851585P18
PMCD9A	Power cable, 18 feet	19B801358P17
PMCN1A	In line connector	19A705839P1
PMLS1F	Speaker, MIL-STD-810C & D, 5" x 5", requires options PMCD7Z & PMCC9M	19A149590P1
PMPD1A	Noise supression kit	19A148539G1
PMSU1C	Alarm (horn) relay kit, requires option PMCD7Z	19A705499P1
PMTA1B	Talk-around kit	344A3803G2
PMZM1K	External speaker kit, requires option PMCD7Z, includes options PMLS1F and PMCC9M	
PMZM5V	Handset extension cable kit, includes options PMCC3S, PMCC1H and PMCN1A (2)	

PLANNING THE INSTALLATION

Before starting, plan the radio installation carefully so that it will be:

- safe for the operator and passengers.
- convenient for the operator to use.
- neat.
- protected from water damage.
- easy to service.
- out of the way of auto mechanics.
- out of the way of passengers.

It is suggested that the radio be installed by one of the many Authorized Service Centers located throughout the United States. These experienced service centers can provide a proper radio installation and make any final adjustments that may be needed.

WARNING

Interference with Vehicular Electronics - Electronic fuel injection systems, electronic anti-skid braking systems, electronic cruise control systems, etc., are typical of the types of electronic devices which may be prone to malfunction due to the lack of protection from radio frequency energy present when transmitting. If the vehicle contains such equipment, consult the dealer for the make of vehicle and enlist his aid in determining if such electronic circuits will perform normally when the radio is transmitting.

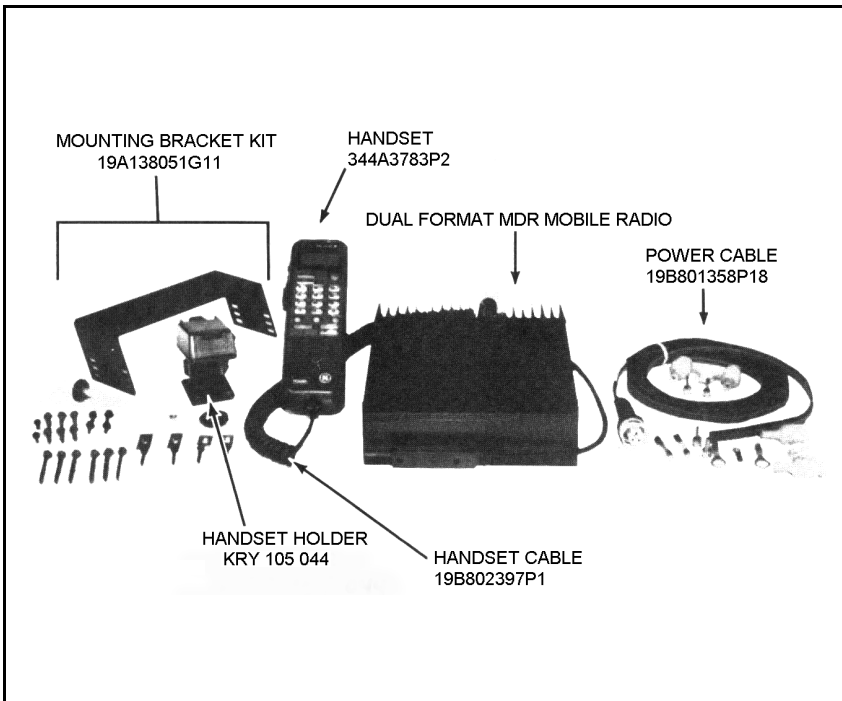

Figure 1 - Dual Format MDR Mobile Radio Components and Mounting Hardware

EQUIPMENT REQUIRED

The equipment required for installing the Dual Format MDR Mobile Radio is listed below:

- Electric drill for drilling mounting holes.
- Drills and circle cutters as follows:
 - No. 31 (1/8-inch) drill for No. 8 self-tapping screws.
 - No. 27 (9/64-inch) drill for No. 10 self-tapping screws.
 - 5/8-inch drill or circle cutter for power cable.
 - 3/4-inch circle cutter, hole saw or socket punch for antenna (optional).
- Phillips and flat-blade screwdrivers, and 1/4-inch and 5/16-inch hex-head drivers for mounting screws.
- No. 15 Torx® driver (ST0606).
- No. 15 Torx® tamper-proof driver (ST0618) if latch security screw (supplied in hardware kit) is used.
- No. 25 Torx® driver (ST0610).
- POZIDRIV® driver for mounting screws.

Torx® is a registered trademark of CAMCAR Division TEXTRON, Inc.
POZIDRIV® is a registered trademark of Phillips International company.

CAUTION

Be careful to avoid damaging some vital part (fuel tank, transmission housing, etc.) of the vehicle when drilling mounting holes. Always check to see how far the mounting screws will extend below the mounting surface before installing.

CAUTION

If pilot holes must be drilled, remove all metal shavings from drilling holes before installing screws.

WARNING

Radio installations in vehicles powered by liquefied petroleum gas must conform to the following requirements.

INSTALLATION IN VEHICLES POWERED BY LIQUEFIED (LP) GAS

Radio installation in vehicles powered by liquefied petroleum gas with the LP-gas container in the trunk or other sealed-off space within the interior of the vehicle must conform to the National Fire Protection Association Standard NFPA 58 which requires that:

- Space containing radio equipment shall be isolated by a seal from the space containing the LP-gas container and its fittings.
- Outside filling connections shall be used for the LP-gas container.
- The LP-gas container space shall be vented to the outside of the vehicle.

MOUNTING LOCATION

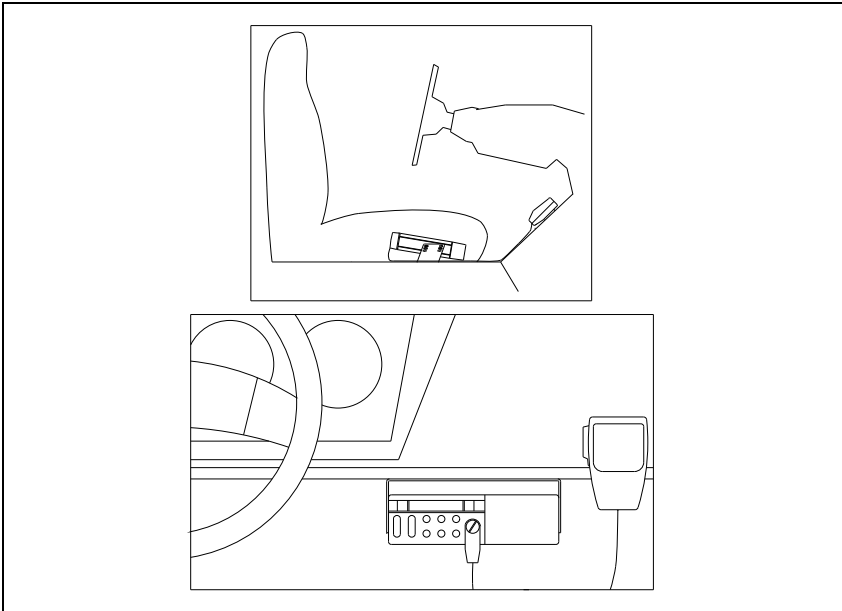

Figure 2 - Typical Hump Or Dash Mount

WARNING

For passenger safety, mount the radio securely so that the unit will not break loose in the event of a collision. This is especially important in station wagons, vans and similar type installations where a loose radio could be extremely dangerous to the vehicle occupants.

INSTALLATION

RUNNING CABLES

To assure the feasibility of the planned cable routings, it is suggested that the cables be run before mounting the radio. Be sure to leave some slack in each cable going to the radio so that the radio may be pulled out for servicing with the power applied and antenna attached.

Try to route the cables away from locations where they will be exposed to heat (exhaust pipes, mufflers, tailpipes, etc.), battery acid, sharp edges, or mechanical damage or where they will be a nuisance to automobile mechanics, the driver, or passengers. Keep wiring away from electronic computer modules. Other electronic modules and ignition circuits to help prevent interference to these components and radio equipment.

In addition, try to utilize existing holes in the fire wall and trunk wall and the channels above or beneath the doors. Also, channels through door and window columns that are convenient for running cables may be used, unless planning to install rigid or flexible conduit in which to run the cables.

Power And Ignition Cable

The power cable consists of a red lead, an orange lead, a black lead, a 3 pin systems plug, and a set of fuses and fuse holders to be installed as indicated in Figure 3.

To install the power cable, drill a 5/8 inch hole in the firewall for the cable run and insert the rubber grommet. Starting with the plug end of the cable at the location of the radio, run the three cable leads through the hole. Secure the cable at several locations within the engine compartment.

To install the fuses:

1. Cut off 12 to 18 inches from the red and orange wires.
2. Strip back the insulation approximately 3/8 of an inch on each end of the wires.
3. Lubricate the wire tips with liquid soap to insert the wires into the fuse holders. Pull the wire ends through the small opening at the end of each fuse holder section and crimp a fuse connector to each wire.

4. Push the prepared fuse connectors into each section of the fuse holders. Place the fuse into a fuse holder section until it seats within the connector. Connect the fuse holder sections to insure a tight fit and connection.

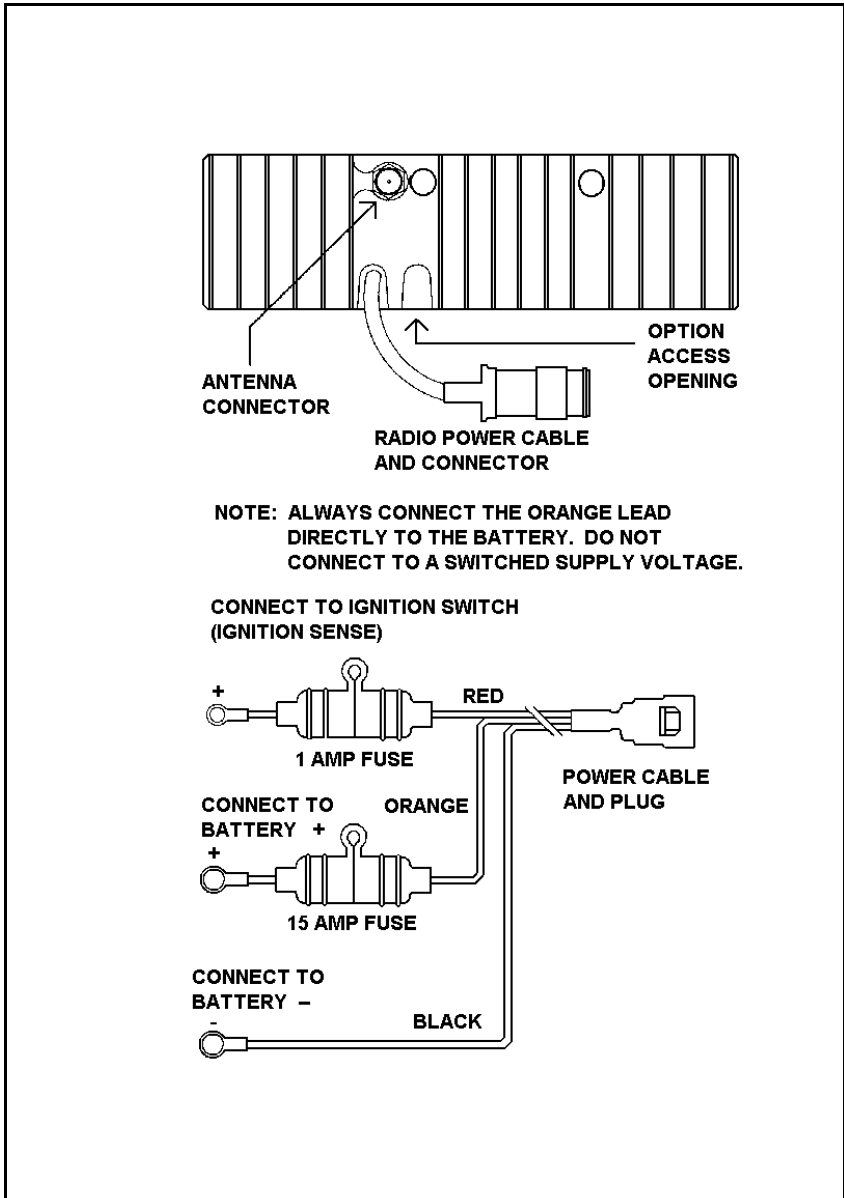

Figure 3 - Power Cable

Connect the orange fused lead to the positive (+) battery terminal, and black to the negative (-) battery terminal. Always locate the fuse as close to the battery as possible.

Connect the red fused lead to the ignition on" sense point (preferably an "Accessory" point on the fuse panel that is switched on when the ignition switch is in the accessory position and in the "run" position). Locate the fuse as close as possible to the accessory point.

NOTE

With some accessory points, the voltage only drops when the ignition switch is in the START position. A connection point should be used where the voltage is completely off when the ignition switch is in the START position.

NOTE

In some installations an additional noise suppression filter such as Ericsson option PMPD1A (19A148539G1) may be needed for satisfactory performance.

CAUTION

Certain problems may be encountered when accessory equipment is connected to the ignition or accessory lines of the vehicle, where these lines may have large filter capacitors or a leakage path present.

If the radio does not turn off within a reasonable amount of time after the ignition is turned off, first try a different accessory or ignition sense pickup point in the vehicle. Many vehicles have more than one circuit that is switched by the ignition switch, and one may be available that does not have large filter capacitors or a leakage path present.

If a different pickup point cannot be found, then add a 470-ohm 1-watt resistor from the ignition sense pickup point to ground. This will discharge the capacitor(s) or reduce the leakage voltage to a low value. Current drain through this resistor will be minimal (less than 0.03A) when the ignition is switched on.

Coil any surplus cables and secure them out of the way with the retaining strap provided. Be sure to leave some slack in the cables going to the radio so that it may be pulled out for servicing with power applied.

MOUNTING THE RADIO

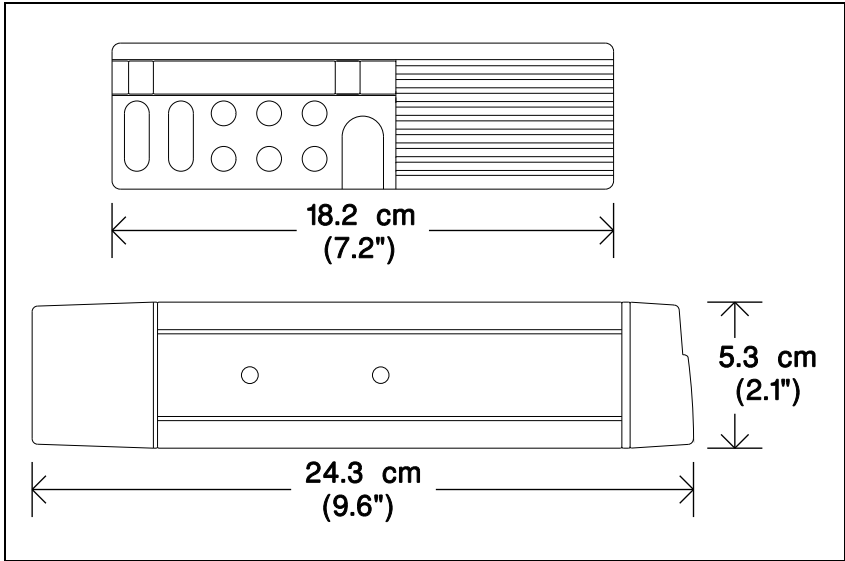

Figure 4 - Mounting Dimensions

Use the supplied mounting bracket as a template to locate the positions for each of the drill holes. Mount the radio as shown in Figure 5. Be sure to leave enough room at the rear of the radio for the cable connections.

TO MOUNT BRACKET, DRILL NO. 24 (9/64 INCH) PILOT HOLES, USE FOUR NO. 10 x 5/8 INCH SCREWS FOR MOUNTING. (USE NO. 10 x 1-1/2 INCH SCREWS IF NEEDED).

THE DOTTED OUTLINES SHOW A SECOND POSITIONING OPTION FOR MOUNTING THE RADIO TO THE TRUNK FLOORBOARD OR FOR HUMP MOUNTING.

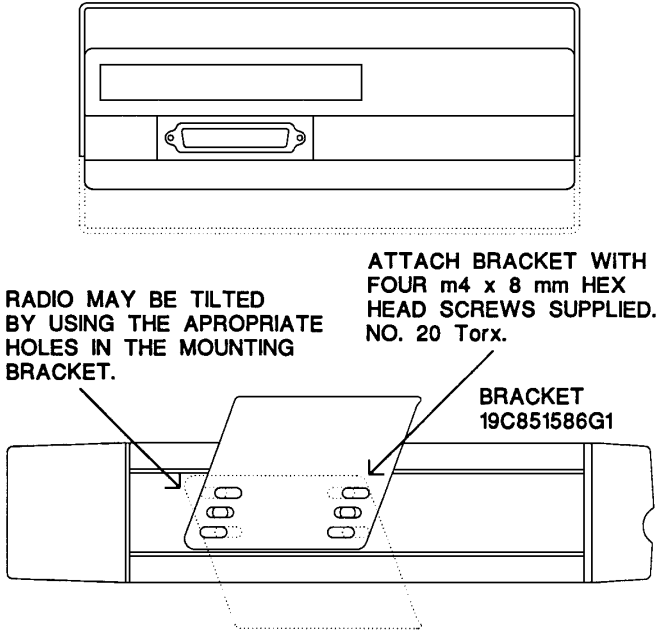

Figure 5 - Mounting Bracket Installation

POSITIVE LATCH HANDSET HOLDER WITH SWIVEL (KRY 105 044)

Mount the handset holder in a location convenient to the operator where it will not interfere with the safe operation of the vehicle or be a hazard to the vehicle passengers. The positive latch handset holder is designed to be mounted in any position using the adjustable mount. The positive latch mechanism prevents the handset from being easily dislodged. The handset holder and the included mounting hardware are shown in Figure 6.

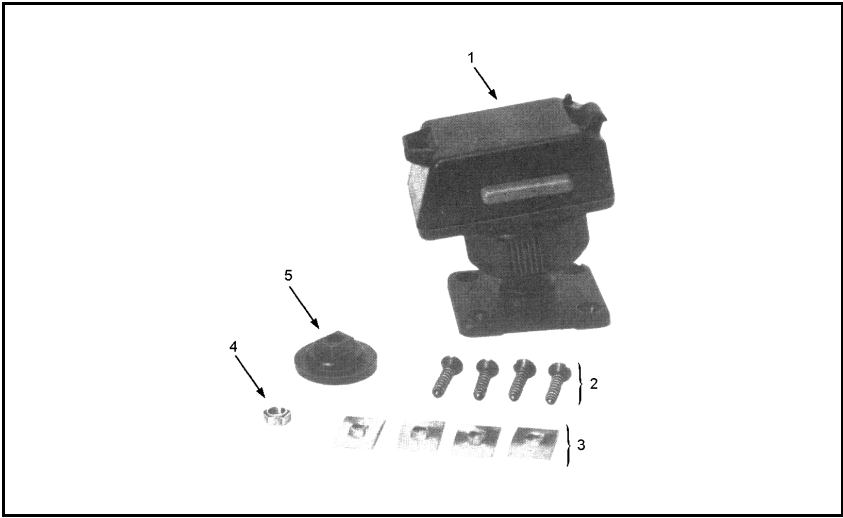

Figure 6 - Handset Holder And Mounting Hardware

NOTE

If mounting on a surface covered with carpet, punch holes with a small punch then make a small slit in the carpet, insert a short piece of metal tubing and drill through the tubing.

NOTE

If mounting to a plastic or thin metal surface or using existing holes, use the sheet nuts (item 3 in Figure 6) on the underside of the holes. Drill a larger hole to permit the screws to turn freely when using these sheet nuts.

Use the following procedure to mount the handset holder:

1. Use the hanger as a template to mark the screw locations and drill the small pilot holes.
2. Use the four #8-18 x 3/4" or #8-18 x 1-1/2 self-tapping screws (items 2 in Figure 6) to mount the holder.

3. Loosen the large knurl nut (item 5 in Figure 7) on the underside of the holder to position the holder to a comfortable position.
4. Tighten the knurl nut when the handset and holder are in the correct position.

NOTE

The positive latch handset holder may be installed as a swivel unit or as a low profile unit. To convert to the low profile unit refer to Figure 7 and perform the steps below.

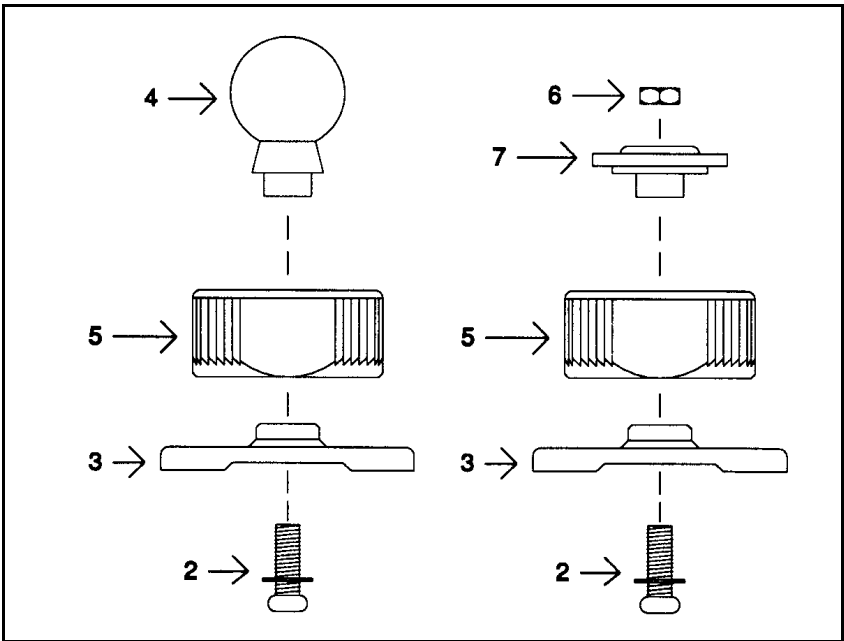

Figure 7 - Handset Holder Base Breakdown

1. Loosen the knurl nut (item 5) and remove the holder. Remove the screw and washer (item 2) in the bottom of the base (item 3) holding the swivel ball stud (item 4). Remove the knurl nut from the swivel ball stud.
2. Insert the nut (item 6) into the recess on the retainer washer (item 7) and then place the retainer washer inside the knurl nut. Fasten the retainer washer and knurl nut to the base with the screw and washer removed in Step 1 above. Attach the holder to the base with the knurl nut.

HANDSET

The handset connects to the Dual Format MDR Mobile Radio using the standard handset cable. Inset the modular plug on the handset cable into the modular jack at the end of the handset. The retaining tab on the plug should snap into place providing a secure connection. To remove the press the retaining tab and pull lightly. The opposite end of the handset cable has a connector which plugs into the receptacle on the front of the radio. Insert the plug and secure it in place using a flat blade screwdriver to tighten the plug's two screws.

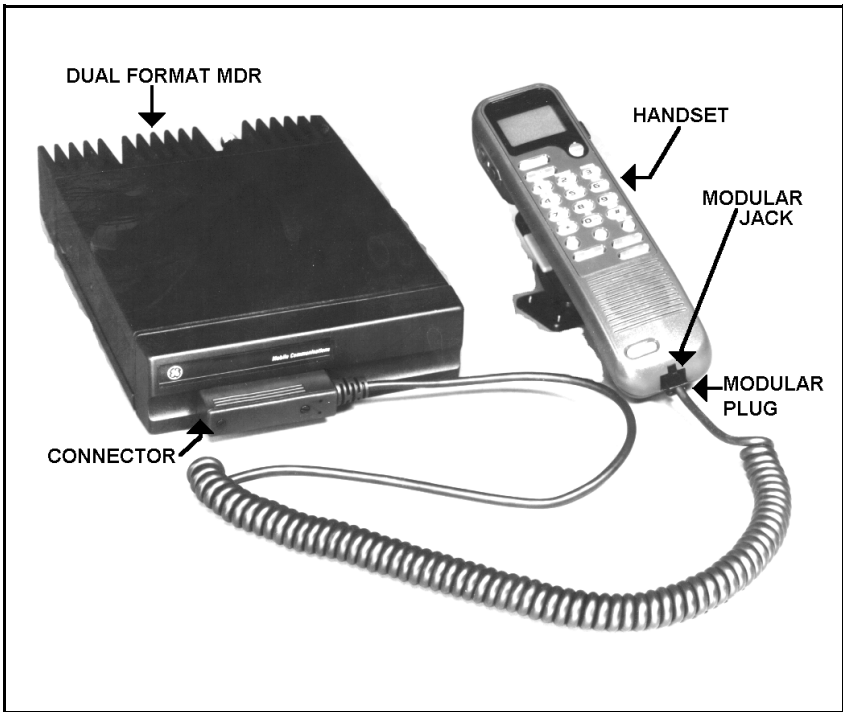

Figure 8 - Dual Format MDR Mobile Radio With Handset And Cable

OPTION INSTALLATION

ANTENNA-OPTION PMAN1L

Installation instructions for the antenna are packaged with the antenna. The antenna must be installed in accordance with good engineering practice for optimum results.

A permanent mount type of antenna should be located in the center of the roof or center of rear deck. Glass mounted antennas should be kept as high as possible in the top center of the rear window. Some states have laws restricting vision obstructing items from the windows. Be familiar with local laws before installing glass mount antennas.

Try to route the cable away from locations where it will be exposed to heat, sharp edges or mechanical damage, and where it will be out of the way of the driver, passengers or vehicles mechanics. Wherever possible, existing holes in the trunk-wall, and the channels above or beneath doors and window columns should be utilized.

Avoid routing the antenna cable near any electronic modules or along side any vehicle wiring.

Connect the antenna cable to the TNC connector on the radio being careful not to twist the cable.

OPTION CABLE KIT - OPTION PMCD7Z

NOTE

Option cable 19C851585G14 has been replaced with 19C851585G18. The G18 is a direct replacement and provides a data interface.

The option cable kit brings all option connections from the System Board through the back of the radio to the outside. This cable is required with all external options. Supplied with the option cable is the empty connector housing which plugs into P2 of the option cable. Pins supplied on the ends of the wires of each option (Molex #39-00-0060) are inserted into this connector housing. Refer to the inter-connection diagrams at the back of this manual. See Figure 9 for pin locations. Table 2 lists wire connections and functions.

1. Remove the bottom cover of the radio by removing the four bottom cover retaining screws. This also releases the top cover.
2. Remove the rubber plug from the option access opening in the rear of the radio adjacent to the power cable. Refer to Figure 3.
3. Plug the option cable into J905 on the System Board and push the strain relief on the cable into the slotted option access opening. Refer to Figure 10.
4. Replace the covers and the four bottom retaining screws.

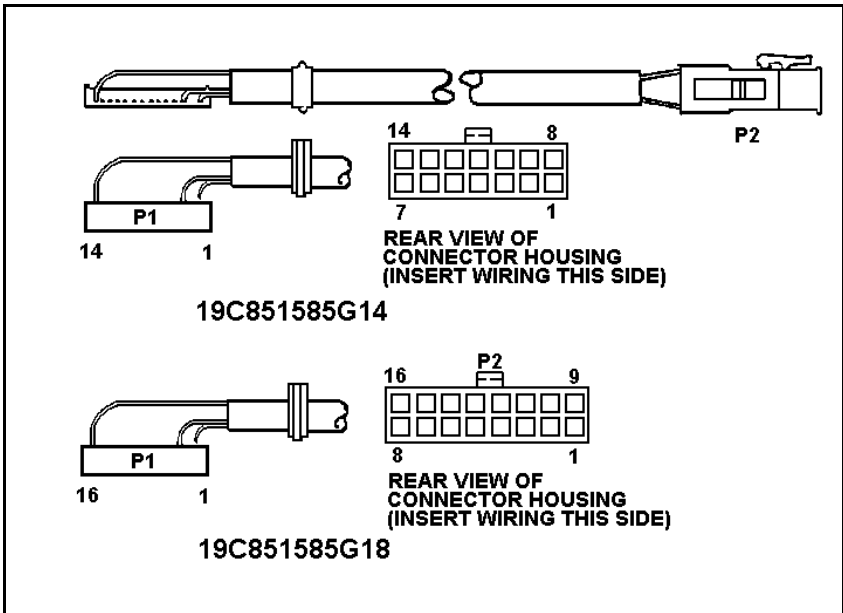

Figure 9- Option Cable Pin Locations

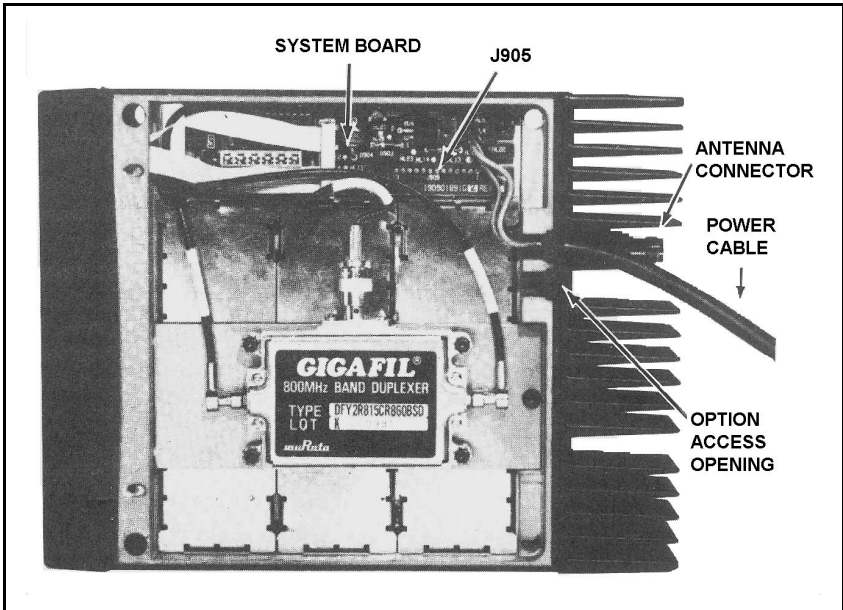

Figure 10 - Bottom View (Cover Removed)

Table 2 - Option Cable Connections

GROUP 14 P1 & P2	FUNCTION	GROUP 18 P1 & P2
1	A-	1
2	SPEAKER LO	2
3	SPEAKER HI	3
4	MIC HI	4
5	SW A+	5
6	<u>SERIAL REQUEST (GE STAR)</u>	6
7	<u>PTT</u>	7
8	<u>CG DISABLE</u>	8
9	SW SPEAKER HI	9
10	<u>AUDIO MUTE</u>	10
11	VOLUME-SQUELCH HI	11
12	MIC LO	12
13	<u>RELAY</u>	13
14	SPARE	14
	DISPLAY SERIAL	15
	KEYPAD SERIAL	16

POWER CABLE - OPTION PMCD9A

Refer to the power and ignition cable installation to install this optional power cord.

NOISE SUPPRESSION KIT - OPTION PMPD1A

Refer to the noise suppression kit option installation manual that is included with this option and the interconnection diagrams at the back of this manual.

ALARM (HORN) RELAY KIT - OPTION PMSUIC

Requires the use of option cable kit - option PMCC3N. The alarm relay kit option consists of the following items:

- (1) Relay (19A149299P1)
- (1) Fuse holder
- (1) Fuse, 1 amp, 250 volt
- 4 feet red wire, AWG #18 with Ring Tongue Terminal for 3/8 stud 6 feet
- black wire, AWG #18 with Molex #39-00-0060 terminal
- (5) Insulated 1/4 inch spade tab receptacles
- (1) Ring Tongue Terminal for 3/8 inch stud
- (1) #8 x 3/4 long Type A sheet metal screw
- (1) Nut Plate for #8 screw

1. Install the option cable kit - option PMCD7Z in the radio.
2. Fasten the relay in the desired location, close to the voltage source, using one #8 x 3/4 inch self-tapping screw.
3. Crimp an insulated 1/4 inch spade tab receptacle to one end of the #18 red wire. Connect the receptacle to relay lug #86. Cut the red lead so the fuse assembly is close to the voltage source. Install the fuse holder. Attach the other end of the fuse lead to the voltage source with appropriate hardware. See Figure 11.
4. Insert the black wire with the Molex terminal into pin 13 of the option connector housing supplied with the option cable. Plug the connector into the option cable.
5. Crimp an insulated 1/4 inch spade tab receptacle to the other end of the black wire. Connect the receptacle to relay lug #85.
6. Connect the horn or light circuit to lugs #30 and #87 (not 87a) using the insulated 1/4 inch spade tab receptacles.

NOTE

The relay contact make/break current and voltage rating is 30 amps at 16 volts.

TALK-AROUND KIT - OPTION PMTA1B

Refer to the talk-around kit option installation manual that is included with this option.

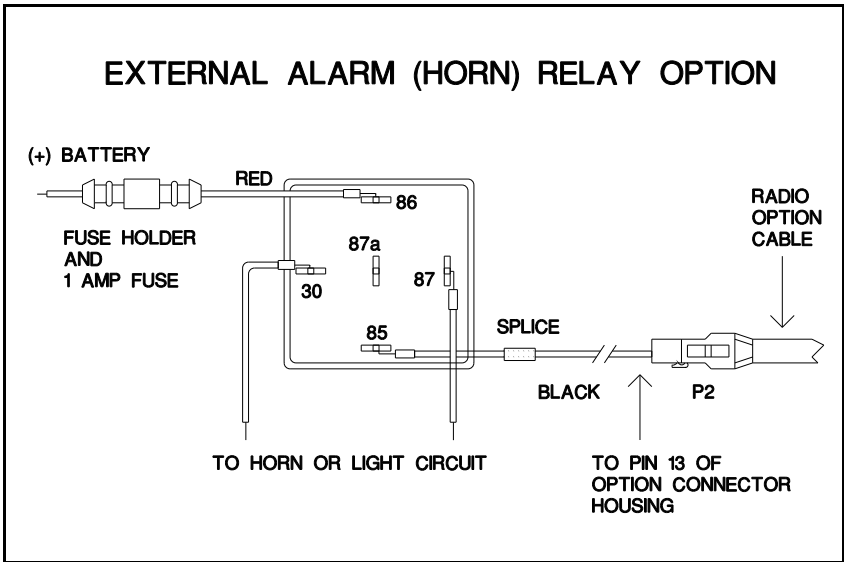

Figure 11 - External Alarm Relay

EXTERNAL SPEAKER KIT - OPTION PMZM1K

The external speaker kit includes a speaker (option PMLSIF) and an external speaker cable (option PMCC9M). External speaker cable (option PMCD1W) is available for use with this kit to place the external speaker up to 16 feet further away from the radio. Installation of this kit requires the option cable kit - option PMD7Z.

1. Mount the speaker so it is directed to the operator but does not cause interference with his vision. It also should not present a hazard in the event of an accident. The speaker may be mounted on the lower edge of the instrument panel, the fire wall, or above the windshield in some trucks. Use the mounting bracket as a template for locating the mounting holes, and mount the speaker as shown in Figure 12.
2. Install the option cable PMCD7Z if not already present.
3. Pins are supplied on the ends of the external speaker cable option PMCC9M. Push these pins into sockets 2 and 9 of the connector housing supplied with the option cable. Refer to Figure 9 and Table 2.
4. Plug the connector housing into P2 of the option cable.
5. Connect the plug end of the external speaker cable to the speaker. If installing the external speaker cable option PMCD1W connect it between the speaker and the plug end of the external speaker cable option PMCC9M.

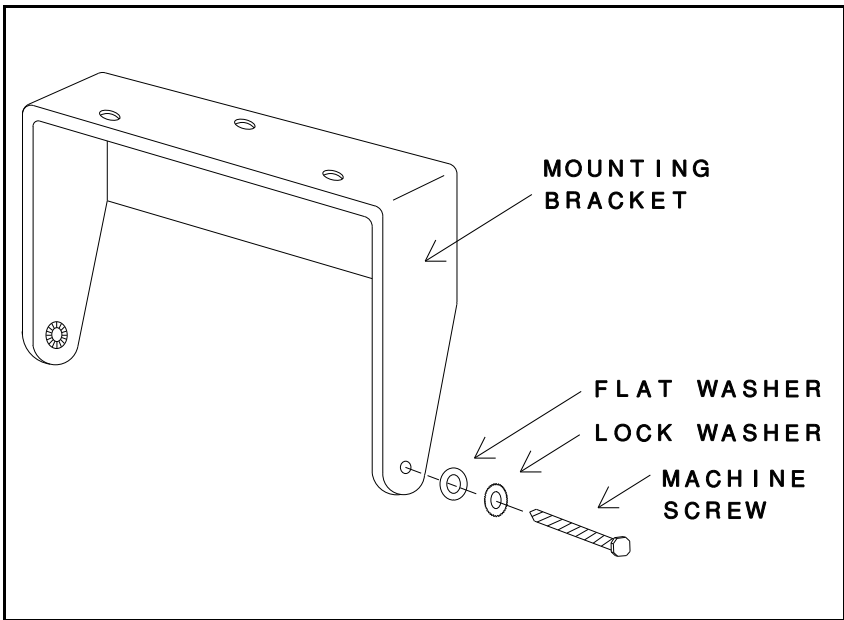
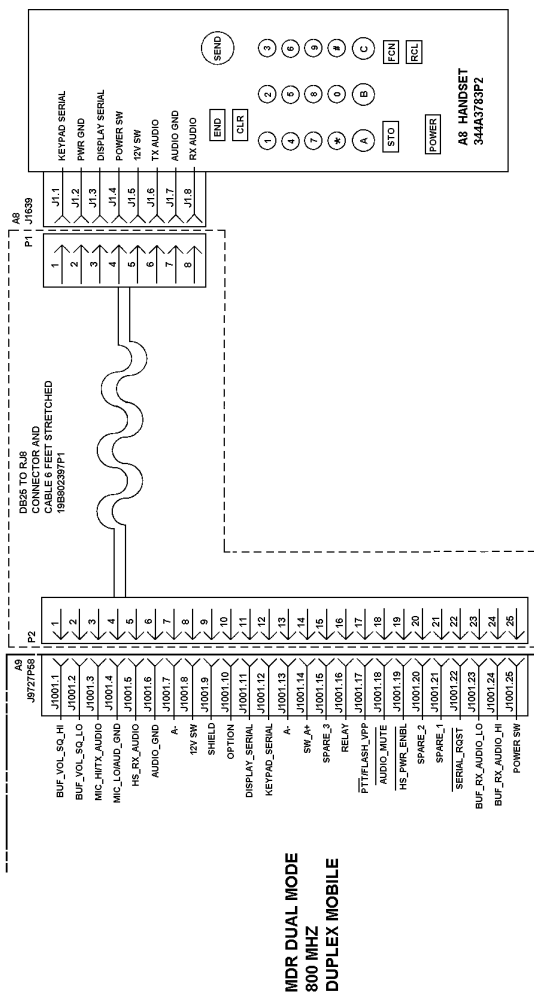

Figure 12 - Mounting The External Speaker

HANDSET EXTENSION CABLE KIT - OPTION PMZM5V

The handset extension cable kit option allows the Dual Format MDR Mobile Radio to be mounted further away from the handset. This option includes two in line connectors (option PMCN1A), a handset extension cable (option PMCC1H) and a handset cable (option PMCC3S). The in line connectors connect to each end of the handset extension cable. One in line connector then connects to the standard handset cable and the other then connects to the handset cable included with this kit. This new handset cable then plugs into the handset.

OPTION INTERCONNECTION DIAGRAM



NOTE: WHEN ORDERING PLEASE REMEMBER THAT ALL OPTION CODES FOR THIS PRODUCT ARE PRECEDED BY THE PRODUCT CODE P#1 (E.G. P#1MNTL)

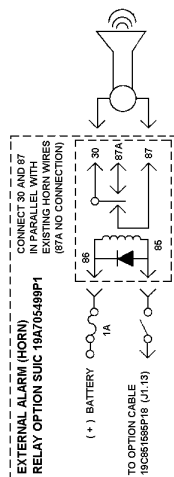

(19D904132, Sh. 1, Rev. 1)

OPTION INTERCONNECTION DIAGRAM

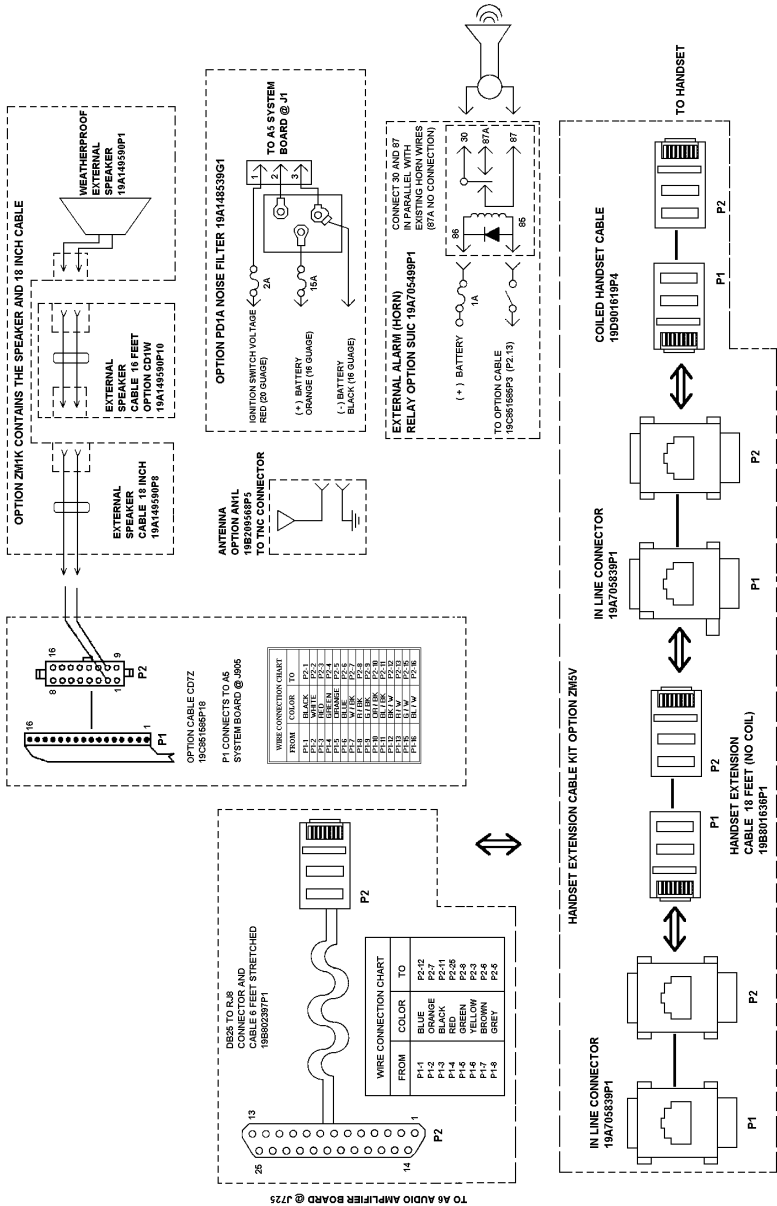

OPTION INTERCONNECTION DIAGRAM

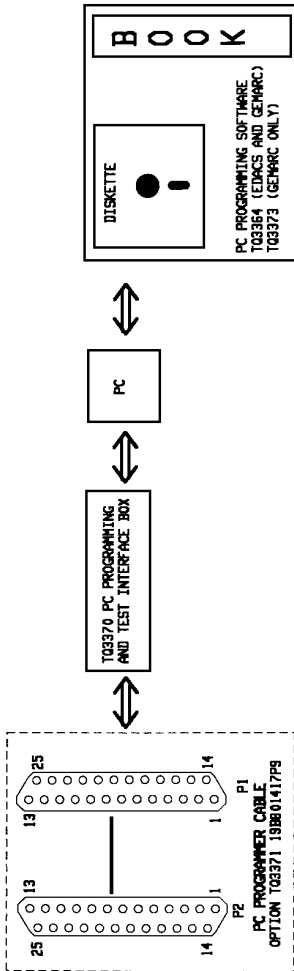

PC PROGRAMMING SOFTWARE
T03354 (CDMS AND GEMARC)
T03373 (GEMARC ONLY)

OPTION NUMBER	OPTIONS AVAILABLE	EGE NUMBER
ANIL	ANTENNA, 800 MHZ, ROOFTOP, TNCX	198240568PS
CBPA	POWER CABLE, 9 FEET	198801358P18
*	POWER CABLE, 18 FEET	198801358P17
*	POWER CABLE, 30 FEET	244030322P1
CCIS	COILED HANDSET CABLE, 6 FEET STRETCHED	198002357P1
ONIA	COILED HANDSET CABLE, 6 FEET STRETCHED	198801618P4
ONIA	IN LINE CONNECTOR	1960058158P1
ZK5V	HANDSET EXTENSION KIT (CCIS, CCIA, ONIA (2))	198801183P1
LS1F	WATER-PROOF SPEAKER 5" X 5"	196146550P1
CSBH	EXTERNAL SPEAKER CABLE, 18 INCHES	1961465108P9
ONIM	EXTERNAL SPEAKER CABLE, 18 FEET (REQUIRES CSBH)	1961465108P10
ONIM	EXTERNAL SPEAKER CABLE, 18 FEET (REQUIRES CSBH)	1961465108P10
CD7Z	OPTION CABLE	190351585P18
TALB	TALKING AND KIT	344030322C2
PDIA	NOISE SUPPRESSION KIT	1961465108P1
PDIA	NOISE SUPPRESSION KIT	1961465108P1
T03371	PC PROGRAMMER CABLE	198801417PS
T03370	PC PROGRAMMING INTERFACE BOX	---
T03354	PC PROGRAMMING SOFTWARE (CDMS)	---
T03354	PC PROGRAMMING SOFTWARE (GEMARC)	---
T03346	DEVELOPER OPTION KIT	---
BUL1	BULLETIN	---
*	SHIVEL HANDSET HOLDER	1960056168P2
ZSSS	MAINTAINING BRACKET KIT	196138051C11
CSBH	18 FEET REMOTE MOUNT KIT (ANBK, CSBH, M831)	---
CC7B	18 FEET REMOTE MOUNT KIT (ANBK, CSBH, M831)	190351585PS
CC7B	ENCODE/DECODE CABLE	1981718861
* STANDARD		

NOTE: WHEN ORDERING PLEASE REMEMBER THAT ALL OPTION CODES FOR THIS PRODUCT ARE PRECEDED BY THE PRODUCT CODE PH (EG. I PHANIL). FOR A COMPLETE LISTING OF OPTIONS SEE YOUR AUTHORIZED EGE DEALER.

Ericsson Inc.
Private Radio Systems
Mountain View Road
Lynchburg, Virginia 24502
1-800-528-7711 (Outside USA, 804-528-7711)

Printed in U.S.A.