

MAINTENANCE MANUAL

RF BOARD

19D902123G22

TABLE OF CONTENTS

	Page
DESCRIPTION	Front Cover
CIRCUIT ANALYSIS	Front Cover
SYNTHESIZER CIRCUIT	Front Cover
TRANSMITTER CIRCUIT	1
RECEIVER CIRCUIT	1
POWER DISTRIBUTION	1
PA MODULE REPLACEMENT	1
BLOCK DIAGRAM	2
OUTLINE DIAGRAM	3
SCHEMATIC DIAGRAM	4
PARTS LIST	7
IC DATA	10

DESCRIPTION

RF Board 19D902123G22 is used in the MDX and MDT Mobile Radios. Circuitry for this 800 MHz board includes frequency synthesizer, transmit exciter, power amplifier, PA power control, receive front end, IF amplifier, FM detector and voltage regulators.

The RF Board mounts in the bottom of the radio's frame assembly. Transmitter and receiver adjustments are accessible from the top of the board. Chip components on the bottom of the board are accessible by removing the friction fit bottom shield. Sealed modules provide RF and mechanical protection for sensitive circuitry. These modules are not serviceable and should be replaced if damaged or found to be defective.

CIRCUIT ANALYSIS

SYNTHESIZER CIRCUIT

The synthesizer generates all transmit and receive RF frequencies for the mobile radio. A block diagram of the frequency synthesizer circuit is shown in Figure 1. When the radio is transmitting, this phase-locked synthesizer circuit locks the VCO on to the actual transmitter's frequency. The VCO's signal is buffered by two (2) common-emitter amplifier circuits and applied to the exciter module. The drive from the VCO ranges from 806.0125-824.9875 MHz when the radio is transmitting on a standard trunking channel (806.0125-824.9875 MHz). When the radio is receiving (851.0125-869.9875 MHz), the synthesizer operates 45 MHz below the receiver's frequency. This provides the required low-side injection for the superheterodyne receiver.

The synthesizer's output signal is generated directly by VCO module U201 and buffered to a level of +8 dBm (6mW) by transistors Q201 and Q205. This +8 dBm drive feeds the receiver's mixer directly and it is attenuated to +3 dBm by resistor R201 to feed the transmitter's exciter module.

The synthesizer frequency is controlled by the microprocessor on the Logic Board. Frequency stability is maintained by temperature compensated crystal oscillator (TCXO) module U204 operating at 12.8 MHz. The oscillator has a stability of 1.5 PPM (0.00015%) over a -30°C to +85°C temperature range. This module determines the overall RF stability of the radio.

The buffered VCO output from Q201 is further buffered by transistor Q204 to feed divide by 128/129 dual-modulus prescaler U205. The prescaler feeds the FIN input of the PLL U206. Within U206, the prescaled signal is further divided down to 12.5 kHz and compared with the reference signal. This reference signal is derived from the 12.8 MHz TCXO module U204. U206 divides the 12.8 MHz signal down to the 12.5 kHz reference frequency.

Divider circuits in U206 are programmed by three inputs from the Logic Board, which are buffered and inverted by transistors Q208, Q209, and Q210. The S ENABLE pulse activates switch U202 to allow a more rapid lock during a channel change.

A LOCK DET signal from the U206 is applied to the microprocessor for processing to prevent transmission when the VCO is not on frequency and to provide an error message to the user.

The BANDSWITCH logic line from the microprocessor is normally high. This high turns on Q211 to activate potentiometer R254. This pot provides transmit modulation adjustment for the standard trunking channels. It attenuates the TX MOD signal applied to the VCO when the radio is transmitting on a normal channel.

TRANSMITTER CIRCUIT

The transmitter consists of a fixed tuned, 200 milliwatt exciter module and a 20-watt PA module, power control and T/R switching circuitry.

Exciter Module

Exciter module A102 operates from a switched 8 volt supply. The exciter module bandwidth is sufficiently wide that both the 806 to 825 MHz and 851-870 MHz bands are allowed. No tuning is required. Both input and output ports operate at 50 ohms impedance. The exciter module provides

typically 20 dB of gain and 200 milliwatts of output power to drive the power amplifier module.

Power Amplifier Module

PA Module U101 requires a drive of 200 milliwatts from the exciter module to deliver up to 20 watts output. The module mounts to the rear heatsink. Input and output impedances are 50 ohms. The module output J103 leads to the input of the 25 watt Power Amplifier (19C851822G1).

The PA module output power is controlled by varying the DC voltage to the module's first stage.

Power Control Circuit

The power control circuitry maintains a constant power level across the band by sampling the power detect output from the directional coupler. POWER DETECT is supplied to the power control circuitry through J101. Thermistors are used to lower the power level when the heatsink temperature goes above +60 C. This circuit controls the supply voltage to the exciter module A102.

The DC POWER DETECT level from the directional coupler feeds the (-) input of amplifier U103-2. Power set potentiometer R111 determines the DC level to the (+) input of U103-2. Amplifier U103-2 amplifies the difference between the (-) and (+) inputs, forcing the output power level to equal the power set level by varying the drive to transistors Q101 and Q102.

Transistor Q101 supplies the control voltage to PA module U101. For example, if the output power level begins to drop below the power set level, the output of U103-2 increases positively, causing Q102 to conduct less. The base of Q101 rises, increasing the control voltage to the PA module, which increases the output power level back to the desired set level.

Thermistors R118 and R129, buffered by transistors Q106 and Q107, reduce the DC level to the (+) input of U103-2 above 80°C. Transistor Q104, capacitor C123, and resistor R105 improve the transient stability of the power control loop when the transmitter is keyed.

Transmit Switch

During transmit, the Audio/Logic Board microprocessor pulls the DPTT line low which is buffered by transistor Q105 before feeding U103-1. The output of U103-1 goes low to turn on transistor Q103 which supplies SWITCHED 8V to the exciter module and the power control circuit.

RECEIVER CIRCUIT

The dual conversion receiver circuit consists of a front end section, a 45.3000 MHz first IF, and a 455 kHz second IF with an FM detector. All audio processing is accomplished on the Audio/Logic Board. See Figure 2.

Front End Section

RF enters the 50 ohm input of the receiver from the receiver side of the directional coupler through J101. The receiver is always on. RF selectivity is provided by two filters Z401 and Z402 on the input and output of RF amplifier transistor Q401. The filters are fixed tuned, 3 pole dielectric resonators with a bandwidth greater than 20 MHz to cover the 851 to 870 MHz band. About 2 dB of passband ripple is typical for this filter pair. Approximately 50 ohm impedance levels exist at the input and output ports of the filters.

RF amplifier transistor Q401 is a low-noise, bipolar transistor biased with DC feedback. The feedback allows a stable operating point of about 10 milliamperes, while allowing direct emitter grounding. Input matching is obtained with stripline L402. The amplifier load is primarily filter Z402.

Capacitors C404, C405, C410 and stripline L403 provide a low Q match to the filter.

Mixer Z403 is a doubly balanced diode mixer. This mixer is driven by a local oscillator signal from the synthesizer at +8 dBm to provide good intermodulation performance, spurious performance and local oscillator isolation. The mixer conversion loss is typically 6 dB.

Converter/IF/Detector IC

IF Amplifier/Detector U501 is an MC3361 IC. Pins 1 and 2 connect to an internally biased oscillator transistor. Crystal Y501 and other external circuitry form a 45.4550 MHz third mode oscillator with the frequency adjusted by inductor L508. The oscillator drives the internal balanced mixer. The 45.3000 MHz IF signal is translated to 455 kHz and appears at Pin 3 of U501. This IF signal is filtered by dual element ceramic filter Z503, amplified by Q504 and filtered by 9 element ceramic filter Z504. This drives the internal 455 kHz amplifier and limiter. The limited 455 kHz, in turn, drives an internal quadrature detector.

The phase-shift network needed by the quadrature detector is provided by inductor L509. The audio output port is Pin 9 on U501. Inductor L509 is adjusted for maximum audio output level. The audio signal at Pin 9 is filtered by resistor R512 and capacitor C519 to reduce IF feedthrough. Buffer amplifier Q503 drives audio potentiometer R513 to

set the amplitude of the VOL/SQ HI signal for proper system operation.

POWER DISTRIBUTION

The 13.8 Vdc source voltage is supplied to the RF Board through connector J704 and feeds power control transistor Q101, PA module U101, and 20V transient suppressor D105. Diode D105 provides reverse polarity protection and protection from noise spikes and other overvoltage transients appearing on the input power cable. Switched 13.6 volts (SW A+) is supplied to the RF Board through J704 and J705 and feeds regulators U102, U207, Q202, and U502. Regulator U102 supplies 8 volts to the transmitter switch, synthesizer 5 volt regulator U203 and to Logic Board A1 through J702. Regulator U207 supplies 8.3 volts to the synthesizer. Regulator U502 supplies 8 volts to the receiver.

PA MODULE REPLACEMENT

To Remove PA Module U101

1. Unsolder the five leads from U101, using either solder removal braid or a mechanical de-soldering tool. These leads are fragile and can be bent very easily. DO NOT unsolder the shield that wraps around the module.
2. Remove the RF Board from the radio chassis assembly. Refer to the disassembly procedure provided in the Service Section. Carefully slide the module out of the shield and away from the board.

To Install PA Module U101

1. Apply some heat sink compound to the metal side of the replacement module.
2. Carefully insert the five leads from the module into the five corresponding printed wire board holes and slide the module into the shield. DO NOT solder the leads yet.
3. Slide the RF Board assembly back into the radio frame. Reinstall all hardware, harnesses, cables, etc. Replace all screws.
4. Install the two PA bracket screws before soldering.
5. Resolder the five leads.

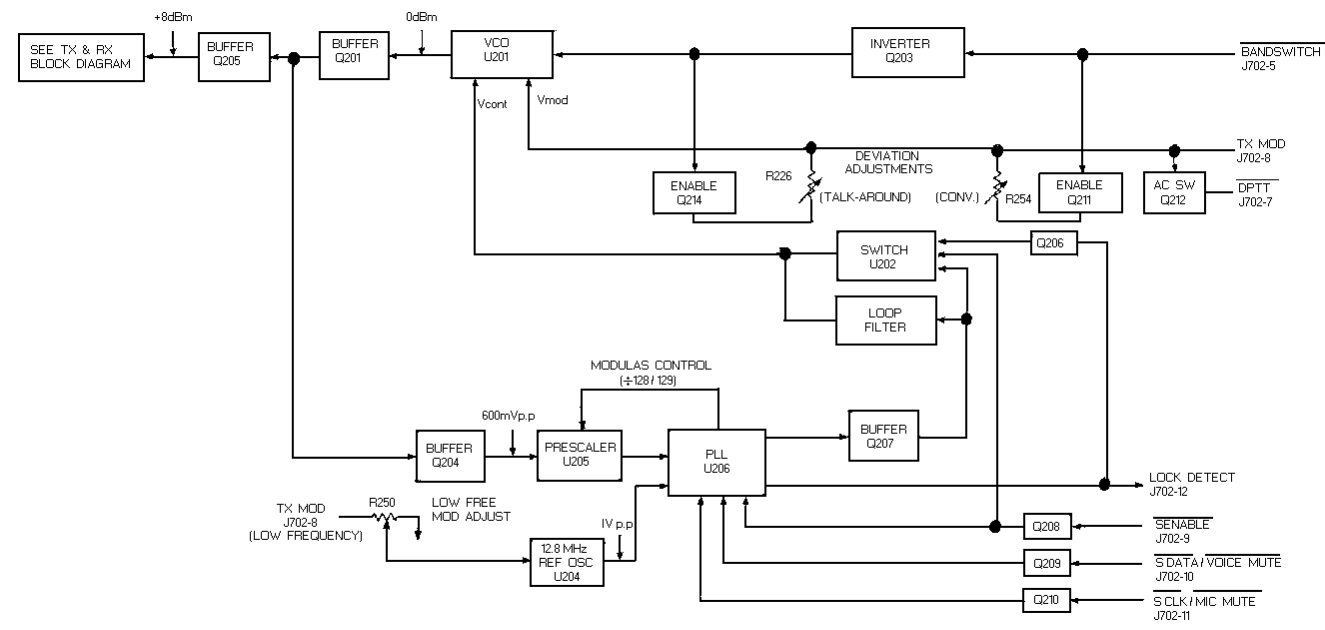

Figure 1 - Synthesizer Block Diagram

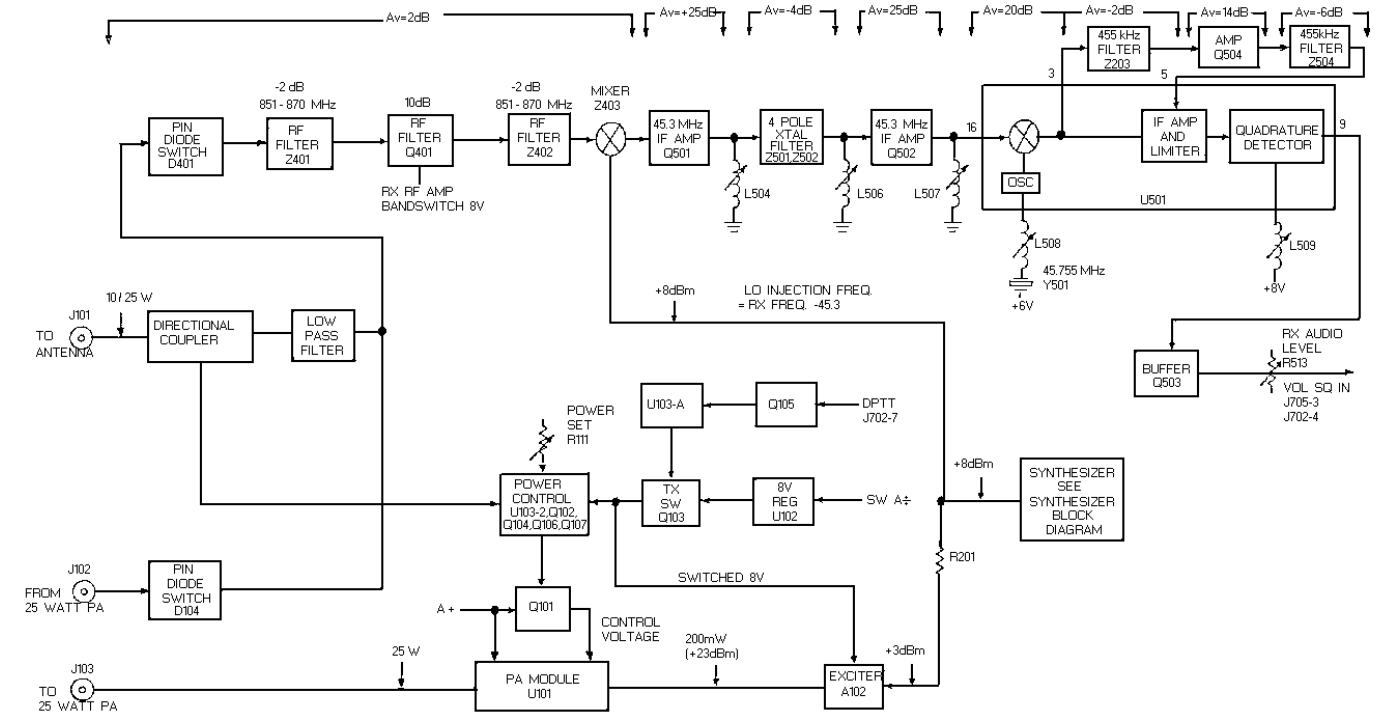
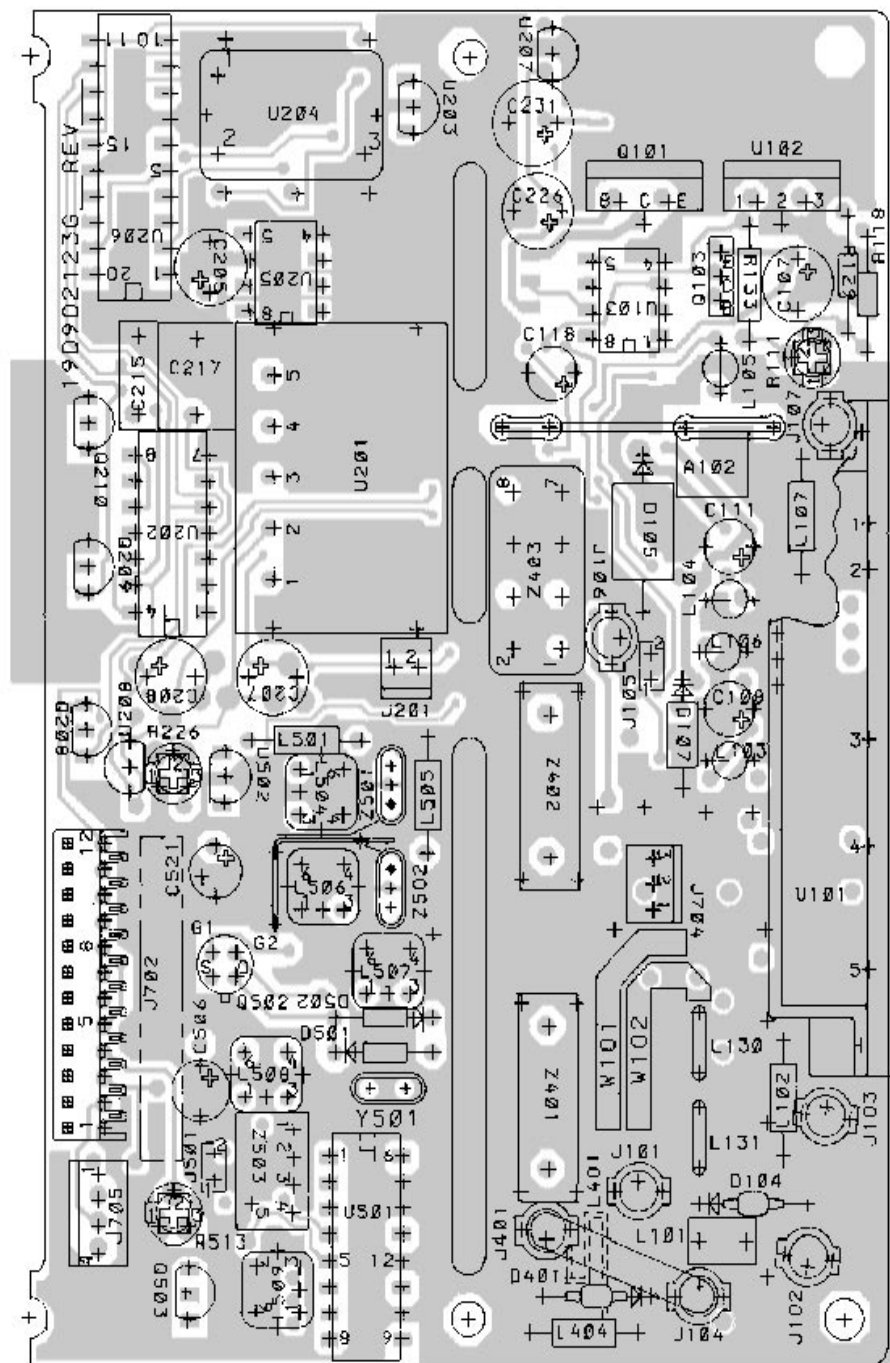

Figure 2 - Transmit/Receive Circuits

COMPONENT SIDE



(19D902123, Sh. 4, Rev. 2)
(19D904057, Sh. 1, Rev. 2)

SOLDER SIDE

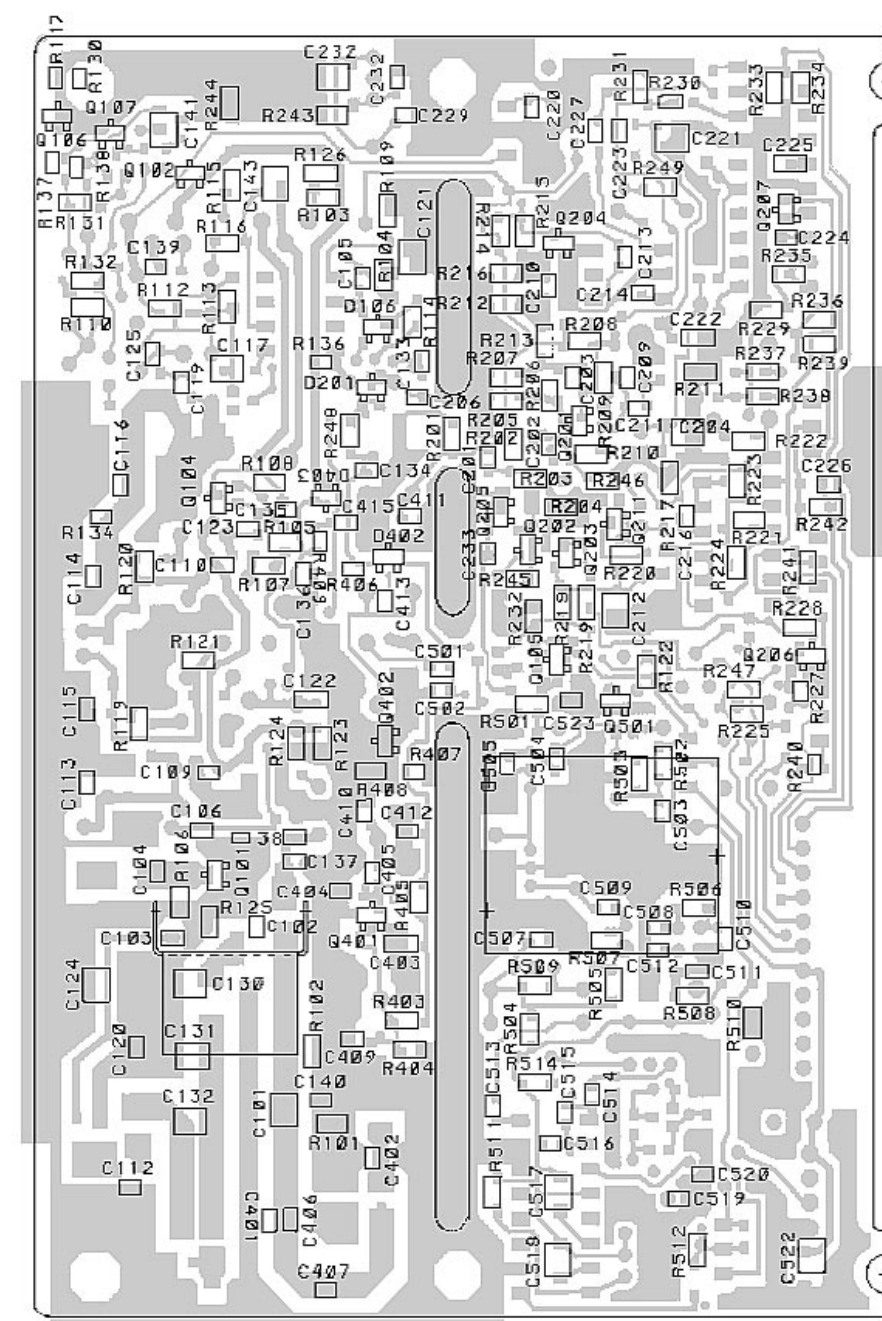

(19D902123, Sh. 4, Rev. 2)
(19D904057, Sh. 2, Rev. 2)

RF BOARD
19D902123G2

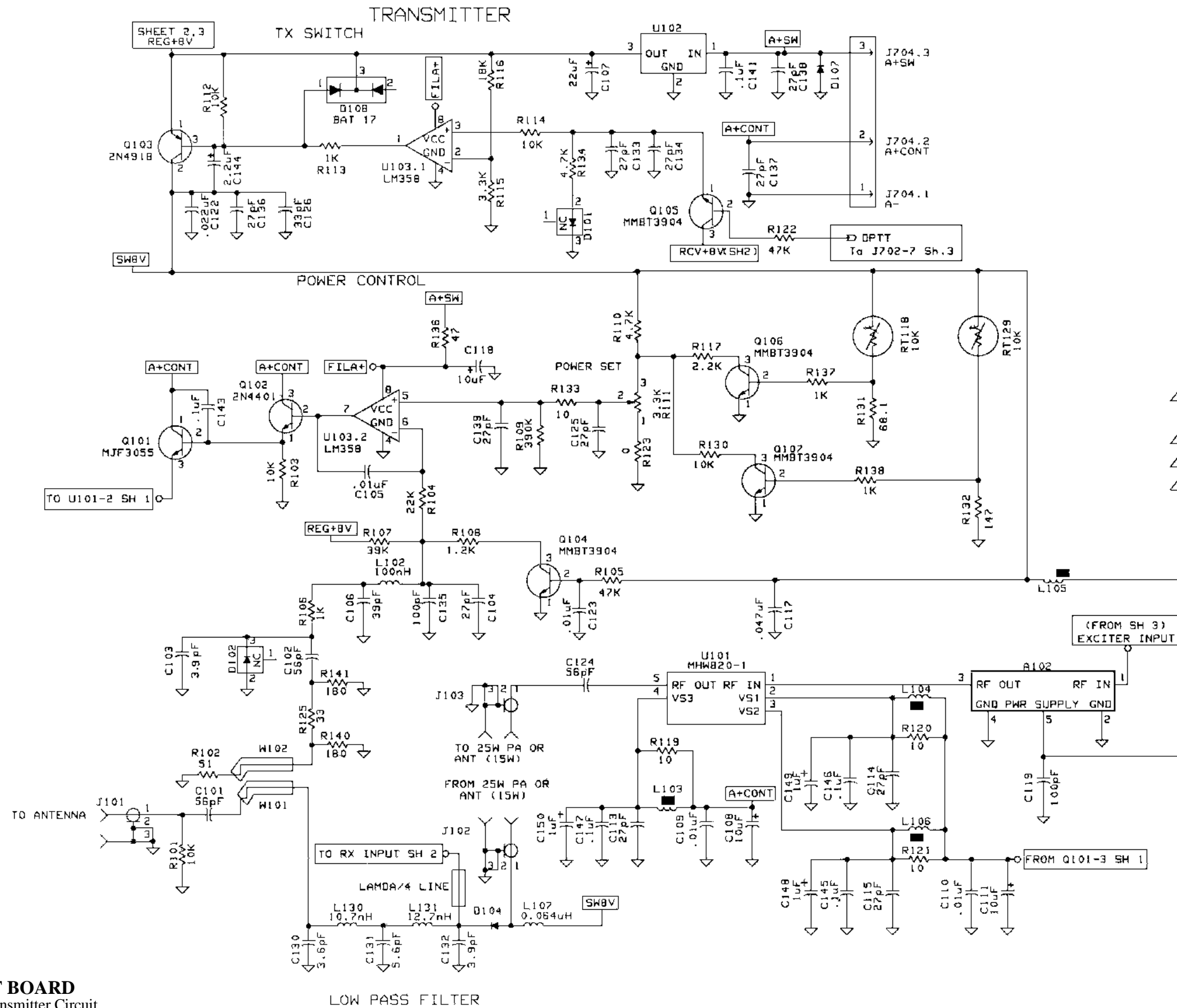

- NOTES:
1. ALL RESISTORS ARE 1/8 WATT UNLESS OTHERWISE SPECIFIED AND RESISTOR VALUES IN OHMS UNLESS FOLLOWED BY K = 1000 OHMS OR M = 1,000,000 OHMS. CAPACITOR VALUES IN PICO FARADS (EQUAL TO MICROMICROFARADS) UNLESS FOLLOWED BY μ = MICROFARADS. INDUCTANCE VALUES IN MICROHENRYS UNLESS FOLLOWED BY mH = MILLIHENRYS, μ H = MICROHENRYS OR H = HENRYS.
 2. INDICATES PART OF PWB.
 3. * INDICATES CRYSTAL FILTER PAIRING (DOTS APPEAR ON TOP OF FILTER CASE).
 4. USED ON BANDSWITCHED RADIOS ONLY.
 5. USED ON NON-BANDSWITCHED RADIOS ONLY.
 6. NOT CURRENTLY USED

THIS SCHEMATIC DIAGRAM APPLIES TO
 MODEL NO. REV LETTER
 19D902123G22 B

RF BOARD
 Transmitter Circuit

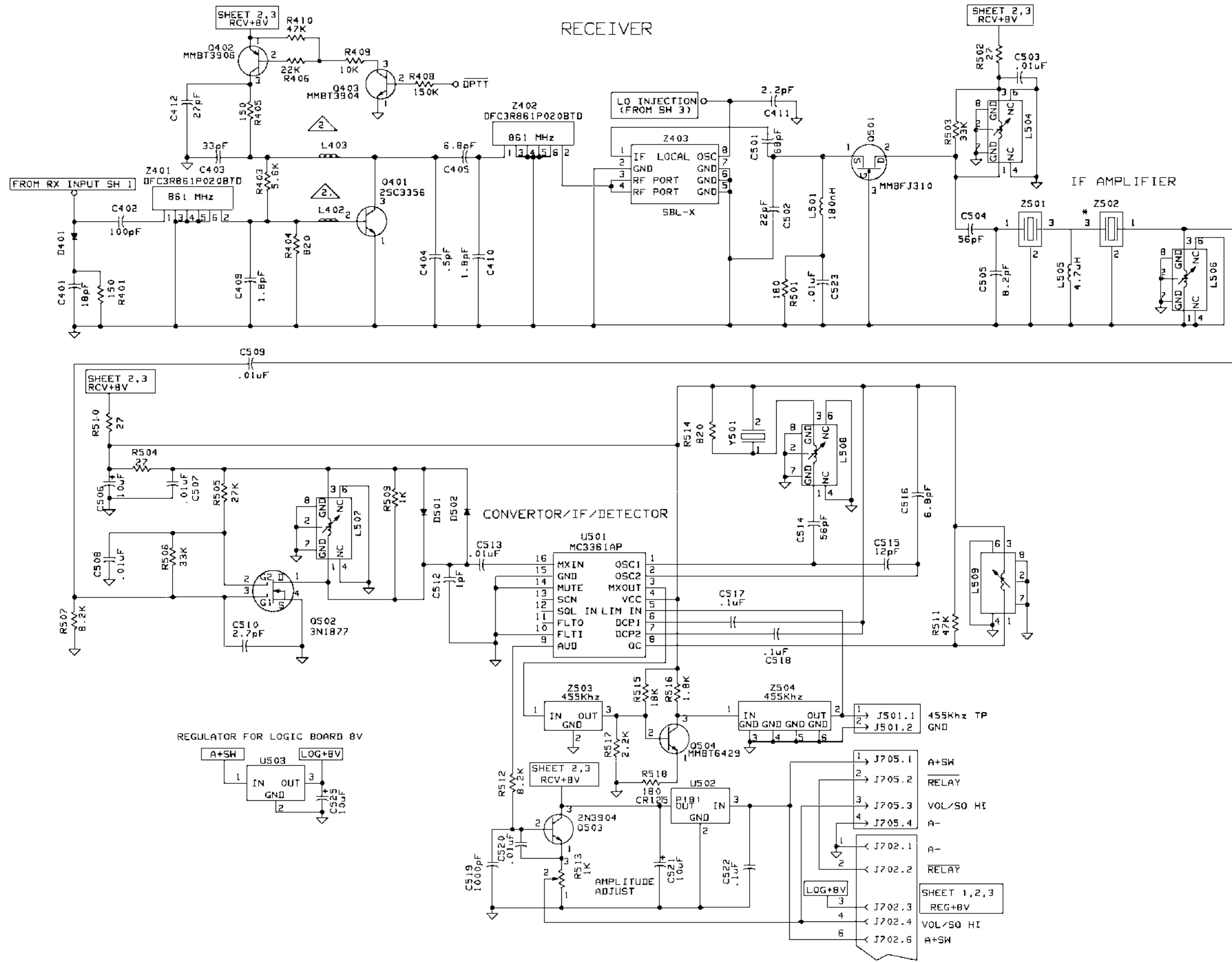

RF BOARD
Receiver Circuit

(19D904058, Sh. 2, Rev. 0)

SYNTHESIZER

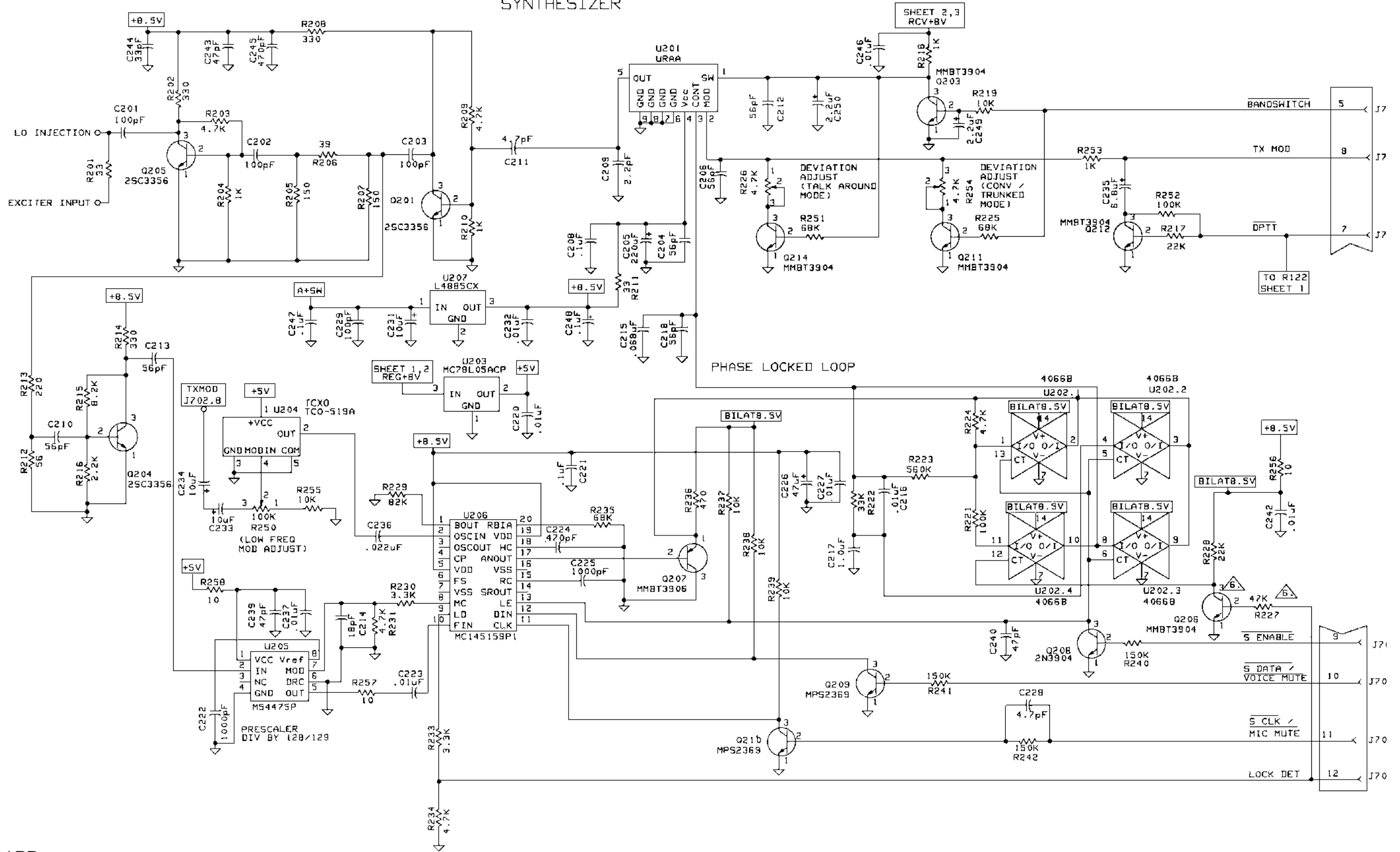

RF BOARD
Synthesizer Circuit

RF BOARD MDX GE-MARC
19D902123G22

SYMBOL	PART NUMBER	DESCRIPTION
----- ASSEMBLIES -----		
A102		Component Board, Exciter (19C851708G1)
----- CAPACITORS -----		
C1 and C2	19A702061P45	Ceramic: 47 pF ±5%, 50 VDCW, temp coef 0 ±30 PPM per °C.
C3	19A702061P8	Ceramic: 3.9 ±0.5 pF, 50 VDCW, temp coef 0 ±120 PPM per °C.
C4	19A702061P77	Ceramic: 470 pF ±5%, 50 VDCW, temp coef 0 ±30 PPM per °C.
C5	19A702061P45	Ceramic: 47 pF ±5%, 50 VDCW, temp coef 0 ±30 PPM per °C.
C6	19A702061P7	Ceramic: 3.3 ±0.5 pF, 50 VDCW, temp coef 0 ±120 PPM per °C.
C7 and C8	19A702061P45	Ceramic: 47 pF ±5%, 50 VDCW, temp coef 0 ±30 PPM per °C.
C9	19A702052P14	Ceramic: 0.01 μF ±10%, 50 VDCW.
C10	19A702061P45	Ceramic: 47 pF ±5%, 50 VDCW, temp coef 0 ±30 PPM per °C.
----- INDUCTORS -----		
L1 and L2		Part Of Printed Wiring Board.
L3	19B800891P2	Coil, RF Choke: sim to Paul Smith SK-890-1.
----- TRANSISTORS -----		
Q1	19A704708P2	Silicon, NPN: sim to NEC 2SC3356.
Q2	19A705436P1	Silicon, NPN: sim to Motorola MRF0211L.
Q3	19A701940P3	Silicon, NPN: sim to SRF-5116.
----- RESISTORS -----		
R1	19B801251P471	Metal film: 470 ohms ±5%, 1/10 w.
R2	19B801251P272	Metal film: 2.7K ohms ±5%, 1/10 w.
R3	19B801251P330	Metal film: 33 ohms ±5%, 1/10 w.
R4	19B801251P331	Metal film: 330 ohms ±5%, 1/10 w.
R5	19B801251P392	Metal film: 3.9K ohms ±5%, 1/10 w.
R6	19B800607P330	Metal film: 33 ohms ±5%, 1/8 w.
R7	19B801251P471	Metal film: 470 ohms ±5%, 1/10 w.
R8	19B801251P332	Metal film: 3.3K ohms ±5%, 1/10 w.
R9 and R10	19B800607P470	Metal film: 47 ohms ±5%, 1/8 w.
----- MISCELLANEOUS -----		
2	19C851707P1	Board, Printed Wiring.
3	19C851708G2	Component Board, Exciter.

SYMBOL	PART NUMBER	DESCRIPTION
----- CAPACITORS -----		
C101	19A705108P31	Capacitor, Mica Chip: 56 pF, ±5%, 500 VDCW, temp coef 0 to 50 PPM per °C.
C102	19A702061P49	Ceramic: 56 pF ±5%, 50 VDCW, temp coef 0 ±30 PPM per °C.
*C103	19A702236P15	Ceramic: 3.9 pF ±5%, 50 VDCW, temp coef 0 ±30 PPM per °C.
C104	19A702236P36	Ceramic: 27 pF ±5%, 50 VDCW, temp coef 0 ±30 PPM per °C.
C105	19A702052P14	Ceramic: 0.01 μF ±10%, 50 VDCW.
C106	19A702236P40	Ceramic: 39 pF ±5%, 50 VDCW, temp coef 0 ±30 PPM per °C.
C107	19A701534P8	Tantalum: 22 μF ±20%, 16 VDCW.
C108	19A703314P10	Electrolytic: 10 μF -10+50%, 50 VDCW; sim to Panasonic LS Series.
C109 and C110	19A702052P14	Ceramic: 0.01 μF ±10%, 50 VDCW.
C111	19A703314P10	Electrolytic: 10 μF -10+50%, 50 VDCW; sim to Panasonic LS Series.
C113 thru C115	19A702061P33	Ceramic: 27 pF ±5%, 50 VDCW, temp coef 0 ±30 PPM per °C.
C117	19A702052P22	Ceramic: 0.047 μF ±10%, 50 VDCW.
C118	19A703314P10	Electrolytic: 10 μF -10+50%, 50 VDCW; sim to Panasonic LS Series.
C119	19A702061P61	Ceramic: 100 pF ±5%, 50 VDCW, temp coef 0 ±30 PPM per °C.
C122	19A702052P28	Ceramic: 0.022 μF ±10%, 50 VDCW.
C123	19A702052P14	Ceramic: 0.01 μF ±10%, 50 VDCW.
C124	19A705108P31	Capacitor, Mica Chip: 56 pF, ±5%, 500 VDCW, temp coef 0 to 50 PPM per °C.
C125	19A702061P33	Ceramic: 27 pF ±5%, 50 VDCW, temp coef 0 ±30 PPM per °C.
C126	19A702236P38	Ceramic: 33 pF ±5%, 50 VDCW, temp coef 0 ±30 PPM per °C.
C130	19A705108P2	Capacitor, Mica Chip: 3.6 ±.5 pF, 500 VDCW, temp coef 0 to 200 PPM per °C.
C131	19A705108P7	Capacitor, Mica Chip: 5.6 ±.5 pF, 500 VDCW, temp coef 0 to 200 PPM per °C.
C132	19A705108P3	Capacitor, Mica Chip: 3.9 ±.5 pF, 500 VDCW, temp coef 0 to 200 PPM per °C.
C133 and C134	19A702061P33	Ceramic: 27 pF ±5%, 50 VDCW, temp coef 0 ±30 PPM per °C.
C135	19A702236P50	Ceramic: 100 pF ±5%, 50 VDCW, temp coef 0 ±30 PPM per °C.
C136 thru C139	19A702061P33	Ceramic: 27 pF ±5%, 50 VDCW, temp coef 0 ±30 PPM per °C.
C141	19A702052P26	Ceramic: 0.1 μF ±10%, 50 VDCW.

SYMBOL	PART NUMBER	DESCRIPTION
----- CAPACITORS -----		
C143	19A702052P26	Ceramic: 0.1 μF ±10%, 50 VDCW.
C144	19A705205P19	Tantalum: 2.2 μF, 10 VDCW; sim to Spargue 293D.
C145 thru C147	19A702052P26	Ceramic: 0.1 μF ±10%, 50 VDCW.
C148 thru C150	344A4196P1R0500	Capacitor, Electrolytic Aluminum; sim to United Chemicon SREC or Nichicon MA series. 1 μF ±20% @ 20°C, 50 VDCW.
C201 thru C203	19A702061P61	Ceramic: 100 pF ±5%, 50 VDCW, temp coef 0 ±30 PPM per °C.
C204	19A702061P49	Ceramic: 56 pF ±5%, 50 VDCW, temp coef 0 ±30 PPM per °C.
C205	19A703314P2	Tantalum: 220 μF, -10+50%, 10 VDCW.
C206	19A702061P49	Ceramic: 56 pF ±5%, 50 VDCW, temp coef 0 ±30 PPM per °C.
C208	19A702052P26	Ceramic: 0.1 μF ±10%, 50 VDCW.
C209	19A702061P5	Ceramic: 2.2 pF ±0.5 pF, 50 VDCW, temp coef 0 ±120 PPM per °C.
C210	19A702061P49	Ceramic: 56 pF ±5%, 50 VDCW, temp coef 0 ±30 PPM per °C.
C211	19A702061P9	Ceramic: 4.7 pF ±0.5 pF, 50 VDCW, temp coef 0 ±60 PPM per °C.
C212 and C213	19A702061P49	Ceramic: 56 pF ±5%, 50 VDCW, temp coef 0 ±30 PPM per °C.
C214	19A702061P25	Ceramic: 18 pF ±5%, 50 VDCW, temp coef 0 ±30 PPM per °C.
C215	19A700004P1	Metallized polyester: 0.068 μF ±10%, 63 VDCW.
C216	19A702052P14	Ceramic: 0.01 μF ±10%, 50 VDCW.
C217	19A700004P11	Metallized Polyester: 1.0 μF ±10%, 63 VDCW.
C218	19A702061P49	Ceramic: 56 pF ±5%, 50 VDCW, temp coef 0 ±30 PPM per °C.
C220	19A702052P14	Ceramic: 0.01 μF ±10%, 50 VDCW.
C221	19A702052P26	Ceramic: 0.1 μF ±10%, 50 VDCW.
C222	19A702061P99	Ceramic: 1000 pF ±5%, 50 VDCW, temp coef 0 ±30 PPM per °C.
C223	19A702052P14	Ceramic: 0.01 μF ±10%, 50 VDCW.
C224	19A702061P77	Ceramic: 470 pF ±5%, 50 VDCW, temp coef 0 ±30 PPM per °C.
C225	19A702061P99	Ceramic: 1000 pF ±5%, 50 VDCW, temp coef 0 ±30 PPM per °C.
C226	19A701534P17	Tantalum: 47 μF ±20%, 10 VDCW.
C227	19A702052P14	Ceramic: 0.01 μF ±10%, 50 VDCW.
C228	19A702061P9	Ceramic: 4.7 pF ±0.5 pF, 50 VDCW, temp coef 0 ±60 PPM per °C.
C229	19A702061P61	Ceramic: 100 pF ±5%, 50 VDCW, temp coef 0 ±30 PPM per °C.

SYMBOL	PART NUMBER	DESCRIPTION
C231	19A703314P10	Electrolytic: 10 μF -10+50%, 50 VDCW; sim to Panasonic LS Series.
C232	19A702052P14	Ceramic: 0.01 μF ±10%, 50 VDCW.
C233 and C234	19A703314P10	Electrolytic: 10 μF -10+50%, 50 VDCW; sim to Panasonic LS Series.
C235	19A705205P5	Tantalum: 6.8 μF, 10 VDCW; sim to Sprague 293D.
C236	19A702052P28	Ceramic: 0.022 μF ±10%, 50 VDCW.
C237	19A702052P14	Ceramic: 0.01 μF ±10%, 50 VDCW.
C239 and C240	19A702061P45	Ceramic: 47 pF ±5%, 50 VDCW, temp coef 0 ±30 PPM per °C.
C242	19A702052P14	Ceramic: 0.01 μF ±10%, 50 VDCW.
C243	19A702061P45	Ceramic: 47 pF ±5%, 50 VDCW, temp coef 0 ±30 PPM per °C.
C244	19A702061P37	Ceramic: 33 pF ±5%, 50 VDCW, temp coef 0 ±30 PPM per °C.
C245	19A702052P3	Ceramic: 470 pF ±10%, 50 VDCW.
C246	19A702052P14	Ceramic: 0.01 μF ±10%, 50 VDCW.
C247	19A702052P26	Ceramic: 0.1 μF ±10%, 50 VDCW. 248
*C248	19A705205P2	Tantalum: 1 μF, ±20%, 16 VDCW.
C249 and C250	19A705205P19	Tantalum: 2.2 μF, 10 VDCW; sim to Spargue 293D.
C401	19A702061P25	Ceramic: 18 pF ±5%, 50 VDCW, temp coef 0 ±30 PPM per °C.
C402	19A702061P61	Ceramic: 100 pF ±5%, 50 VDCW, temp coef 0 ±30 PPM per °C.
C403	19A702236P38	Ceramic: 33 pF ±5%, 50 VDCW, temp coef 0 ±30 PPM per °C.
C404	19A702236P1	Ceramic: 0.5 pF ±1 pF, 50 VDCW, temp coef 0 ±30 PPM per °C.
C405	19A702236P21	Ceramic: 6.8 pF ±0.5 pF, 50 VDCW, temp coef 0 ±60 PPM per °C.
C409 and C410	19A702236P9	Ceramic: 1.8 pF ±0.25 pF, 50 VDCW, temp coef 0 ±30 PPM per °C.
C411	19A702236P10	Ceramic: 2.2 pF ±2.5 pF, 50 VDCW, temp coef 0 ±30 PPM per °C.
C412	19A702061P33	Ceramic: 27 pF ±5%, 50 VDCW, temp coef 0 ±30 PPM per °C.
C501	19A702061P53	Ceramic: 68 pF ±5%, 50 VDCW, temp coef 0 ±30 PPM per °C.
C502	19A702061P29	Ceramic: 22 pF ±5%, 50 VDCW, temp coef 0 ±30 PPM per °C.
C503	19A702052P14	Ceramic: 0.01 μF ±10%, 50 VDCW.
C504	19A702061P49	Ceramic: 56 pF ±5%, 50 VDCW, temp coef 0 ±30 PPM per °C.
C505	19A702061P49	Ceramic: 56 pF ±5%, 50 VDCW, temp coef 0 ±30 PPM per °C.
C506	19A701534P7	Tantalum: 10 μF ±20%, 16 VDCW.

*COMPONENTS, ADDED OR DELETED OR CHANGED BY PRODUCTION CHANGES

SYMBOL	PART NUMBER	DESCRIPTION
C507 thru C509	19A702052P14	Ceramic: 0.01 μ F \pm 10%, 50 VDCW.
C510	19A702061P6	Ceramic: 2.7 pF \pm 0.5 pF, 50 VDCW, temp coef 0 \pm 120 PPM per $^{\circ}$ C.
C511	19A702052P14	Ceramic: 0.01 μ F \pm 10%, 50 VDCW.
C512	19A702061P1	Ceramic: 1 pF \pm 0.5 pF, 50 VDCW.
C513	19A702052P14	Ceramic: 0.01 μ F \pm 10%, 50 VDCW.
C514	19A702061P49	Ceramic: 56 pF \pm 5%, 50 VDCW, temp coef 0 \pm 30 PPM per $^{\circ}$ C.
C515	19A702061P17	Ceramic: 12 pF \pm 5%, 50 VDCW, temp coef 0 \pm 30 PPM per $^{\circ}$ C.
C516	19A702061P11	Ceramic: 6.8 pF \pm 0.5 pF, 50 VDCW, temp coef 0 \pm 60 PPM per $^{\circ}$ C.
C517 and C518	19A702052P26	Ceramic: 0.1 μ F \pm 10%, 50 VDCW.
C519	19A702052P5	Ceramic: 1000 pF \pm 10%, 50 VDCW.
C520	19A702052P14	Ceramic: 0.01 μ F \pm 10%, 50 VDCW.
C521	19A703314P10	Electrolytic: 10 μ F -10+50%, 50 VDCW; sim to Panasonic LS Series.
C522	19A702052P26	Ceramic: 0.1 μ F \pm 10%, 50 VDCW.
C523	19A702052P14	Ceramic: 0.01 μ F \pm 10%, 50 VDCW.
C525	19A703314P10	Electrolytic: 10 μ F -10+50%, 50 VDCW; sim to Panasonic LS Series.
----- DIODES -----		
D101	19A702525P2	Silicon, PIN: sim to MMBV3401.
D102	19A705377P1	Silicon, Hot Carrier: sim to MMB0201.
D104	344A3316P1	Diode, Silicon, PIN: sim to Macon PIN diode MA4P1250 surface mount.
D107	T324ADP1041	Silicon: Rectifier; sim to 1N4004.
D108	19A134587P2	Silicon: 2 diodes, Common Cathode: sim to BAV 70.
D401	344A3316P1	Diode, Silicon, PIN: sim to Macon PIN diode MA4P1250 surface mount.
D501 and D502	19A700028P1	Silicon: 75 mA, 75 PIV; sim to 1N4148.
----- JACKS -----		
J101 thru J103	19B801341P1	RF Jack.
J501	19A700072P1	Printed wire: 2 contacts rated @ 2.5 amps; sim to Molex 22-03-2021.
J702	19A704779P11	Connector; sim to Molex 22-17-2122.
J704	19A700072P29	Printed wire: 3 contacts rated at 2.5 amps; sim to Molex 22-27-2031.
J705	19A700072P30	Printed wire: 4 contacts rated at 2.5 amps; sim to Molex 22-27-2041.
----- INDUCTORS -----		
L102	19A700024P1	Coil, RF: 100 nH \pm 10%, 0.08 ohms DC res max, 100 v.
L103 thru L106	19A704921P1	Coil.
L107	19B800891P5	Coil, RF: .064 μ H; sim to Paul Smith SK-890-1.

SYMBOL	PART NUMBER	DESCRIPTION
L130	19B800890P2	RF: sim to Paul Smith SK-891-1.
L131	19B800890P4	RF: sim to Paul Smith SK-891-1.
L402 and L403		Part of printed wire board.
L501	19A700024P4	Coil, RF: 180 nH \pm 10%.
L504	19B801413P4	Coil, 39 MHz.
L505	19B209420P21	Coil, RF: 4.7 μ H \pm 5%, 1.20 ohms DC res max; sim to Jeffers 4436-8J.
L506 thru L508	19B801413P4	Coil, 39 MHz.
L509	19B801415P2	Transformer, 455 KHz.: sim to AEPD 162B3277P17.
----- TRANSISTORS -----		
Q101	344A3225P1	Silicon, NPN: sim to MJF3055.
Q102	19A702503P2	Silicon, NPN: sim to 2N4401.
Q103	19A704972P1	Silicon, PNP: sim to Motorola 2N4918.
Q104 thru Q107	19A700076P2	Silicon, NPN: sim to MMBT3904, low profile.
Q201	19A704708P2	Silicon, NPN: sim to NEC 2SC3356.
Q203	19A700076P2	Silicon, NPN: sim to MMBT3904, low profile.
Q204 and Q205	19A704708P2	Silicon, NPN: sim to NEC 2SC3356.
Q206	19A700076P2	Silicon, NPN: sim to MMBT3904, low profile.
Q207	19A700059P2	Silicon, PNP: sim to MMBT3906, low profile.
Q208	19A700023P2	Silicon, NPN: sim to 2N3904.
Q209 and Q210	19A702084P2	Silicon, NPN: sim to MPS 2369.
Q211 and Q212	19A700076P2	Silicon, NPN: sim to MMBT3904, low profile.
Q214	19A700076P2	Silicon, NPN: sim to MMBT3904, low profile.
Q401	19A704708P2	Silicon, NPN: sim to NEC 2SC3356.
Q402	19A700059P2	Silicon, PNP: sim to MMBT3906, low profile.
Q403	19A700076P2	Silicon, NPN: sim to MMBT3904, low profile.
Q501	19A702524P2	N-Type, field effect; sim to MMBFU310.
Q502	19A116818P3	N Channel, field effect; sim to Type 3N1877.
Q503	19A700023P2	Silicon, NPN: sim to 2N3904.
Q504	19A134739P2	Silicon, NPN.
----- RESISTORS -----		
R101	19B800607P103	Metal film: 10K ohms \pm 5%, 1/8 w.
R102	19B800607P510	Metal film: 51 ohms \pm 5%, 1/8 w.
R103	19B800607P103	Metal film: 10K ohms \pm 5%, 1/8 w.
R104	19B800607P223	Metal film: 22K ohms \pm 5%, 1/8 w.
R105	19B800607P473	Metal film: 47K ohms \pm 5%, 1/8 w.
R106	19B800607P102	Metal film: 1K ohms \pm 5%, 1/8 w.

SYMBOL	PART NUMBER	DESCRIPTION
R107	19B800607P393	Metal film: 39K ohms \pm 5%, 1/8 w.
R108	19B800607P122	Metal film: 1.2K ohms \pm 5%, 1/8 w.
R109	19B800607P394	Metal film: 390K ohms \pm 5%, 1/8 w.
R110	19B800607P472	Metal film: 4.7K ohms \pm 5%, 1/8 w.
R111	19B800779P7	Variable: 3.3K ohms \pm 25%, 100 VDCW, .3 w.
R112	19B800607P103	Metal film: 10K ohms \pm 5%, 1/8 w.
R113	19B800607P102	Metal film: 1K ohms \pm 5%, 1/8 w.
R114	19B800607P103	Metal film: 10K ohms \pm 5%, 1/8 w.
R115	19B800607P332	Metal film: 3.3K ohms \pm 5%, 1/8 w.
R116	19B800607P183	Metal film: 18K ohms \pm 5%, 1/8 w.
R117	19B801251P222	Metal film: 2.2K ohms \pm 5%, 1/10 w.
R118	19A701864P4	Thermal 10K ohms \pm 10%, sim to Midwest Components 2H-103.
R119 thru R121	19B800607P100	Metal film: 10 ohms \pm 5%, 1/8 w.
R122	19B800607P473	Metal film: 47K ohms \pm 5%, 1/8 w.
R123	19B800607P1	Metal film: Jumper.
R125	19B800607P330	Metal film: 33 ohms \pm 5%, 1/8 w.
R129	19A701864P4	Thermal 10K ohms \pm 10%, sim to Midwest Components 2H-103.
R130	19B801251P103	Metal film: 10K ohms \pm 5%, 1/10 w.
R131	19A702931P81	Metal film: 68.1 ohms \pm 1%, 200 VDCW, 1/8 w.
R132	19A702931P117	Metal film: 147 ohms \pm 1%, 200 VDCW, 1/8 w.
R133	19A700106P15	Composition: 10 ohms \pm 5%, 1/4 w.
R134	19B800607P472	Metal film: 4.7K ohms \pm 5%, 1/8 w.
R136	19B801251P470	Metal film: 47 ohms \pm 5%, 1/10 w.
R137 and R138	19B801251P102	Metal film: 1K ohms \pm 5%, 1/10 w.
R140 and R141	19B800607P181	Metal film: 180 ohms \pm 5%, 1/8 w.
R201	19B800607P330	Metal film: 33 ohms \pm 5%, 1/8 w.
R202	19B800607P331	Metal film: 330 ohms \pm 5%, 1/8 w.
R203	19B800607P472	Metal film: 4.7K ohms \pm 5%, 1/8 w.
R204	19B800607P102	Metal film: 1K ohms \pm 5%, 1/8 w.
R205	19B800607P151	Metal film: 150 ohms \pm 5%, 1/8 w.
R206	19B800607P390	Metal film: 39 ohms \pm 5%, 1/8 w.
R207	19B800607P151	Metal film: 150 ohms \pm 5%, 1/8 w.
R208	19B800607P331	Metal film: 330 ohms \pm 5%, 1/8 w.
R209	19B800607P472	Metal film: 4.7K ohms \pm 5%, 1/8 w.
R210	19B800607P102	Metal film: 1K ohms \pm 5%, 1/8 w.
R211	19B801251P330	Metal film: 33 ohms \pm 5%, 1/10 w.
R212	19B800607P560	Metal film: 56 ohms \pm 5%, 1/8 w.
R213	19B800607P221	Metal film: 220 ohms \pm 5%, 1/8 w.
R214	19B800607P331	Metal film: 330 ohms \pm 5%, 1/8 w.
R215	19B800607P822	Metal film: 8.2K ohms \pm 5%, 1/8 w.
R216	19B800607P222	Metal film: 2.2K ohms \pm 5%, 1/8 w.
R217	19B800607P223	Metal film: 22K ohms \pm 5%, 1/8 w.
R218	19B800607P102	Metal film: 1K ohms \pm 5%, 1/8 w.
R219	19B800607P103	Metal film: 10K ohms \pm 5%, 1/8 w.

SYMBOL	PART NUMBER	DESCRIPTION
R221	19B800607P104	Metal film: 100K ohms \pm 5%, 1/8 w.
R222	19B800607P333	Metal film: 33K ohms \pm 5%, 1/8 w.
R223	19B800607P564	Metal film: 560K ohms \pm 5%, 1/8 w.
R224	19B800607P472	Metal film: 4.7K ohms \pm 5%, 1/8 w.
R225	19B800607P683	Metal film: 68K ohms \pm 5%, 1/8 w.
R226	19B800779P8	Variable, cermet: 4.7K ohms \pm 25%, .3 w.
R227	19B801251P473	Metal film: 47K ohms \pm 5%, 1/10 w.
R228	19B800607P223	Metal film: 22K ohms \pm 5%, 1/8 w.
R229	19B800607P823	Metal film: 82K ohms \pm 5%, 1/8 w.
R230	19B801251P332	Metal film: 3.3K ohms \pm 5%, 1/10 w.
R231	19B800607P472	Metal film: 4.7K ohms \pm 5%, 1/8 w.
R233	19B800607P332	Metal film: 3.3K ohms \pm 5%, 1/8 w.
R234	19B800607P472	Metal film: 4.7K ohms \pm 5%, 1/8 w.
R235	19B800607P683	Metal film: 68K ohms \pm 5%, 1/8 w.
R236	19B800607P471	Metal film: 470 ohms \pm 5%, 1/8 w.
R237 thru R239	19B800607P103	Metal film: 10K ohms \pm 5%, 1/8 w.
R240	19B801251P154	Metal film: 150K ohms \pm 5%, 1/10 w.
R241 and R242	19B800607P154	Metal film: 150K ohms \pm 5%, 1/8 w.
R250	19B800779P16	Variable: 100K ohms \pm 25%, 100 VDCW, .3 watt.
R251	19B800607P683	Metal film: 68K ohms \pm 5%, 1/8 w.
R252	19B800607P104	Metal film: 100K ohms \pm 5%, 1/8 w.
R253	19B800607P102	Metal film: 1K ohms \pm 5%, 1/8 w.
R254	19B800779P8	Variable, cermet: 4.7K ohms \pm 25%, .3 w.
R255	19B800607P103	Metal film: 10K ohms \pm 5%, 1/8 w.
R256 thru R258	19B800607P100	Metal film: 10 ohms \pm 5%, 1/8 w.
R401	19B801486P151	Metal film: 150 ohms \pm 5%, 1/2 w.
R403	19B800607P562	Metal film: 5.6K ohms \pm 5%, 1/8 w.
R404	19B800607P821	Metal film: 820 ohms \pm 5%, 1/8 w.
R405	19B800607P151	Metal film: 150 ohms \pm 5%, 1/8 w.
R406	19B801251P223	Metal film: 22K ohms \pm 5%, 1/10 w.
R408	19B800607P154	Metal film: 150K ohms \pm 5%, 1/10 w.
R409	19B801251P103	Metal film: 10K ohms \pm 5%, 1/10 w.
R410	19B801251P473	Metal film: 47K ohms \pm 5%, 1/10 w.
R501	19B801251P181	Metal film: 180 ohms \pm 5%, 1/10 w.
R502	19B800607P270	Metal film: 27 ohms \pm 5%, 1/8 w.
R503	19B800607P333	Metal film: 33K ohms \pm 5%, 1/8 w.
R504	19B800607P270	Metal film: 27 ohms \pm 5%, 1/8 w.
R505	19B800607P273	Metal film: 27K ohms \pm 5%, 1/8 w.
R506	19B800607P333	Metal film: 33K ohms \pm 5%, 1/8 w.
R507	19B800607P822	Metal film: 8.2K ohms \pm 5%, 1/8 w.
R508	19B800607P101	Metal film: 100 ohms \pm 5%, 1/8 w.
R509	19B800607P102	Metal film: 1K ohms \pm 5%, 1/8 w.
R510	19B800607P270	Metal film: 27 ohms \pm 5%, 1/8 w.
R511	19B800607P473	Metal film: 47K ohms \pm 5%, 1/8 w.
R512	19B800607P822	Metal film: 8.2K ohms \pm 5%, 1/8 w.
R513	19B800779P4	Variable: 1K ohms \pm 25%, 100VDCW, .3 w.

SYMBOL	PART NUMBER	DESCRIPTION
R514	19B800607P821	Metal film: 820 ohms $\pm 5\%$, 1/8 w.
R515	19B801251P183	Metal film: 18K ohms $\pm 5\%$, 1/10 w.
R516	19B801251P182	Metal film: 1.8K ohms $\pm 5\%$, 1/10 w.
R517	19B801251P222	Metal film: 2.2K ohms $\pm 5\%$, 1/10 w.
R518	19B801251P181	Metal film: 180 ohms $\pm 5\%$, 1/10 w.
----- INTEGRATED CIRCUITS -----		
U101		RF amplifier: sim to MHW820-1. (Part of next higher assembly; not included with RB Board 19D902123G22).
U102	19A134717P3	Linear: 8 Volt Regulator; sim to MC7808CT.
U103	19A701789P2	Linear: Dual Op Amp; sim to LM358.
U201	19A704902P1	VCO: DUAL BAND: 806-825 MHz, 851-870 MHz; sim to: ALPS URAA.
U202	19A700029P44	Digital: BILATERAL SWITCH.
U203	19A704971P1	Linear: +5 Volt Regulator: sim to MC78L05ACP.
U204	19B801351P16	Oscillator, crystal, temperature compensated.
U205	19A704740P1	Digital: Divider; sim to Mitsubishi M54475P.
U206	19B800902P4	Digital: Synthesizer, CMOS Serial Input.
U207	344A3820P1	Voltage Regulator: Linear, 8.5 Vdc.; sim to SGS 4885CX.
U501	19A704619P1	Linear: Osc/Mixer/IF/Det/Amp; sim to MC3361AP.
U502	19A704073P2	Linear: 8 Volt Regulator; sim to MC78L08CP.
U503	344A3820P1	Voltage Regulator: Linear, 8.5 Vdc.; sim to SGS 4885CX.
----- CRYSTALS -----		
Y501	19B233066G18	Filter, crystal.
----- FILTER -----		
Z401 and Z402	19A704888P1	Bandpass Filter, 851-871 MHz; sim to Murata DFC3R861P020BTD.
Z403	19B801025P2	Balanced Mixer. sim to Mini-Circuits SBL-1X.
Z501	19A705613G34	Filter, Crystal pair, Reference frequency 45.3 MHz.
Z502		(Order Z501)
----- MISCELLANEOUS -----		
Z503	19B801021P6	Bandpass Filter: 455 ± 0.5 kHz, 3 dB BW ± 0.5 kHz, 9 dB BW ± 7 kHz; sim to TOKO SHCFM2-455D.
Z504	19B801021P5	Bandpass Filter: 455 ± 1.5 kHz, 3 dB BW 6 kHz min; sim to Murata CF2M-455E10.
----- MISCELLANEOUS -----		
	19B801566P1	Shield.
	19B801566P2	Shield.
	19B801578P1	Shield, Clip.
	19D904057P1	Board, Printed Wire, Auto-transfer panel.
	19D902123G23	Board, Component, RF.
	19B802774P1	Shield.

PRODUCTION CHANGES

Changes in the equipment to improve performance or to simplify circuits are identified by a "Revision Letter", which is stamped after the model number of the unit. The revision stamped on the unit includes all previous revisions. Refer to the Parts List for the descriptions of parts affected by these revisions.

Rev. A - RF BOARD 19D902123G22

To meet specifications of transmit power, C103 changed from 4.7pF (19A702236P17) to 3.9pF (19A702236P15).

Rev. B - RF BOARD 19D902123G22

To simplify production, PWB was changed.

Rev. B - RF BOARD 19D902123G22

To eliminate oscillation at the output of the 8.5v regulator, C248 changed from 0.1uF (19A702052P26) to Tantalum: 1uF 20% 16VDCW (19A705205P2).

PA MODULE U101
19A143904P2

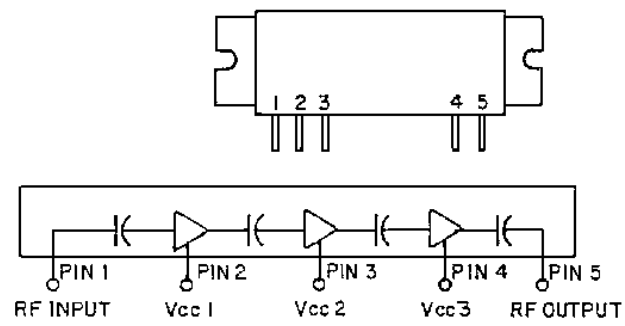

VOLTAGE REGULATOR U102
19A134717P3

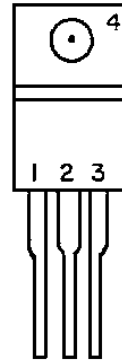

- 1. INPUT
- 2. COMMON
- 3. OUTPUT
- 4. TAB COMMON

TCXO U204
19B801351P16

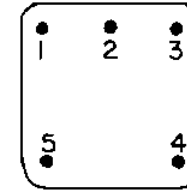

PIN CONNECTIONS

- 1. +Vcc
- 2. OUTPUT
- 3. COMMON & CASE
- 4. COMMON & CASE *
- 5. COMMON & CASE
- * PIN 4 IS PERMISSIBLE BUT NOT NECESSARY FOR OPERATION.

VOLTAGE REGULATOR U207, U503
344A3820P1

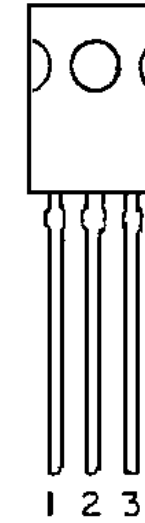

BOTTOM VIEW

PIN IDENTIFICATION

- PIN 1 INPUT
- PIN 2 GROUND
- PIN 3 OUTPUT

DUAL OP AMP U103
19A701789P2

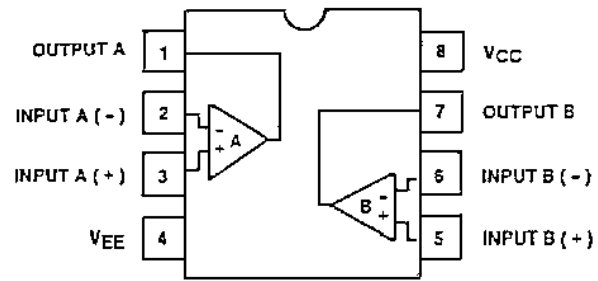

VCO U201
19A704902P1

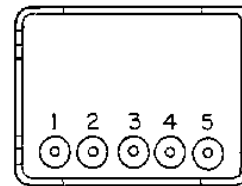

PIN	FUNCTION
1	SWITCH
2	MOD
3	CONTROL
4	Vcc
5	OUTPUT

DIVIDER U205
19A704740P1

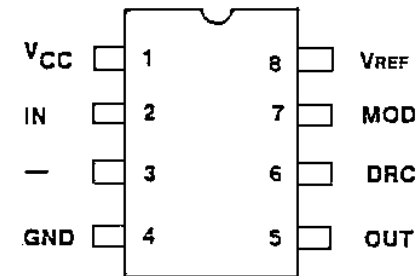

- 1 V_{CC} POWER SUPPLY (+5V)
- 2 IN SIGNAL INPUT
- 3 — NO CONNECTION
- 4 GND GROUND
- 5 OUT SIGNAL OUT
- 6 DRC DIVISION RATIO CONTROL (V_{CC}: 64/65, OPEN: 128/129)
- 7 MOD MODULUS CONTROL INPUT
- 8 VREF REFERENCE BIAS INPUT

QUAD BILATERAL SWITCH U202
19A700029P44

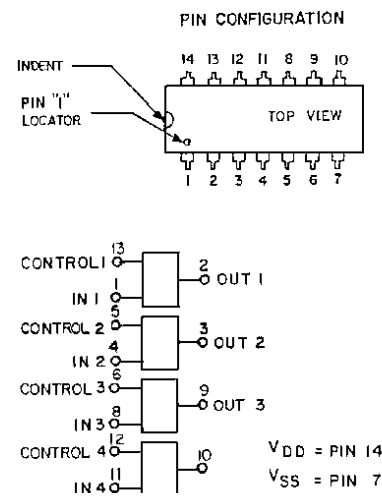

VOLTAGE REGULATOR U303
19A704971P1

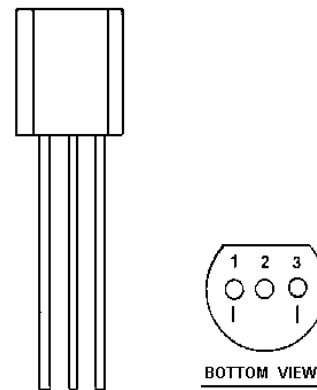

PIN IDENTIFICATION

- PIN 1. OUTPUT
- PIN 2. GROUND
- PIN 3. INPUT

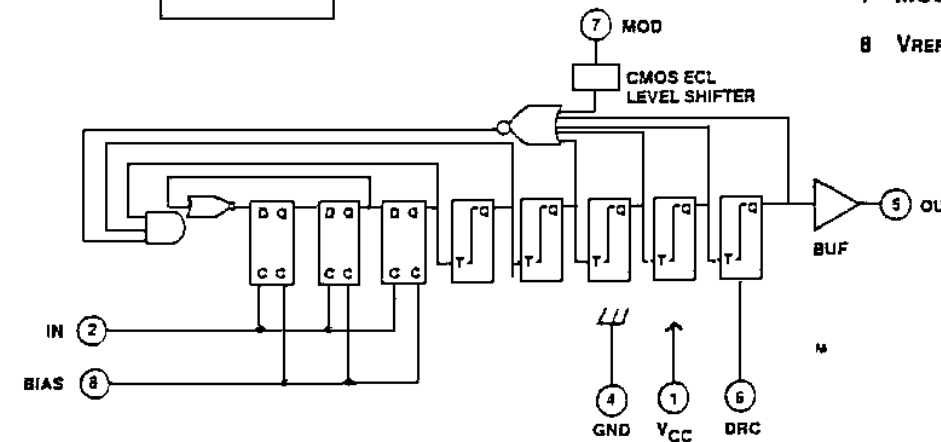

SYNTHESIZER U206
19B800902P4

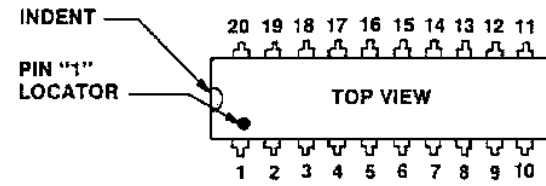

PIN DESCRIPTION

OUTPUT BIAS	1	TOP	20	RAMP BIAS
OSC. IN	2		19	VDD'
OSC. OUT	3		18	HOLD CAP.
CHARGE PULSE	4		17	ANALOG PD OUT
VDD	5		16	VSS'
(FS) FREQ. SENSE	6		15	RAMP CAP.
VSS	7		14	SHIFT REGISTER OUPUT
MODULUS CONTROL	8		13	LATCH ENABLE
2 π LOCK DETECTOR	9		12	DATA IN
FIN	10		11	CLOCK

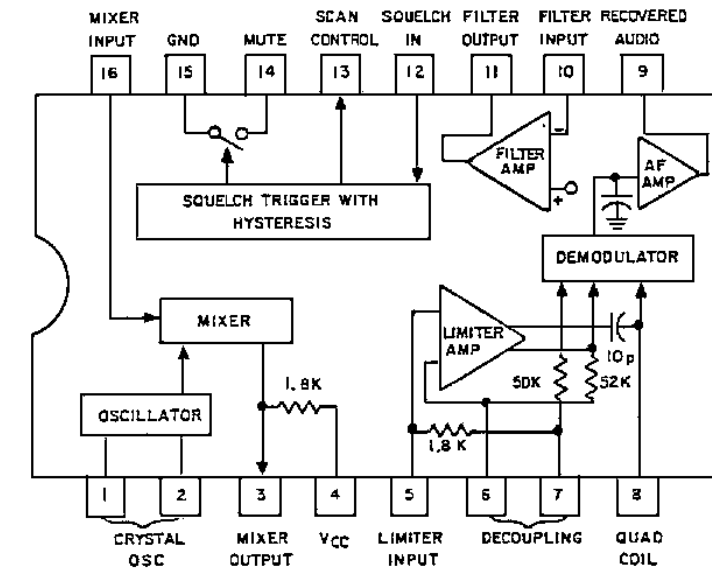
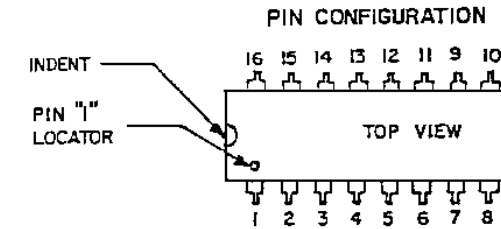

BLOCK DIAGRAM

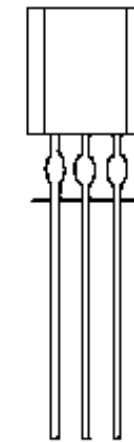
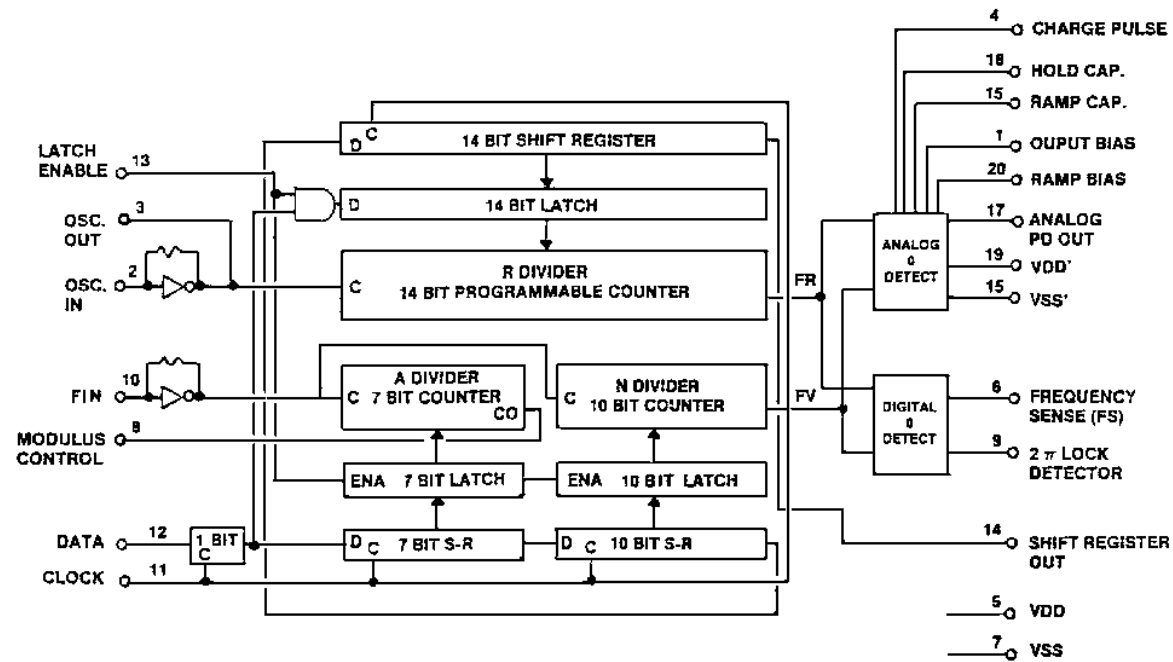

VOLTAGE REGULATOR U502
19A704073P2



BOTTOM VIEW

PIN 1 - OUTPUT
PIN 2 - GROUND
PIN 3 - INPUT