



SERVICE SECTION FOR MDX SERIES, 800 MHz

TABLE OF CONTENTS

	<u>Page</u>
DESCRIPTION	1
INITIAL ADJUSTMENT	1
TRANSMITTER ADJUSTMENT	1
RECEIVER ADJUSTMENT	1
RE-INSTALLATION	1
PREVENTIVE MAINTENANCE	1
CONNECTIONS	1
ELECTRICAL SYSTEM	1
MECHANICAL INSPECTION	1
ANTENNA	1
ALIGNMENT	1
FREQUENCY CHECK	1
STATIC HANDLING PRECAUTIONS	1
DISASSEMBLY PROCEDURES	2
TO REMOVE BOTTOM COVER	2
TO REMOVE TOP COVER	2
TO REMOVE RF BOARD A2	2
TO REMOVE THE FRONT CAP ASSEMBLY	2
TO REMOVE AUDIO AMPLIFIER BOARD A3	2
TO REMOVE AUDIO/LOGIC BOARD A1	2
TO REMOVE SYSTEM BOARD A5	2
PA BOARD REMOVAL	2
TO REMOVE THE DISPLAY BOARD	2
COMPONENT REPLACEMENT	2
SURFACE MOUNTED COMPONENTS	2
To Remove Surface Mounted Components	3
To Replace Surface Mounted Components	3
To Replace Surface Mounted Integrated Circuits	3
TROUBLESHOOTING PROCEDURES	3
ERROR MESSAGES	3
SYMPTOMS AND CHECKS	3
TEST PREPARATION	4
TEST MODE COMMANDS	4
Key/Unkey Transmitter (XMIT CON)	4
Mute/Unmute Receiver Audio (AUDI CON)	4
Mute/Umute Mic Audio (PHON CON)	4
Generate Dotting (4800 CPS)	4
Generate Pseudo Random HS Data (9600 PRD)	5
Encode Channel Guard Tone (150 CPS)	5
Report Receiver Carrier Sense (CAS TEST)	5
Across Band Switching (BAND SWT)	5
Generate Alert Tone (ALERT TN)	5
External RAM Test (RAM TEST)	5
Software Version Number (UPR)	5
Checksum Test (PROG TS)	5

Continued



TABLE OF CONTENTS (Continued)

	<u>Page</u>
Default Set-up (DEFAULT)	5
Set Channel (SET CHAN)	5
Volume Control (VOLUME)	5
11 Hertz Test (11 HERTZ)	5
TX Standard Busy Tone (TX BSYTN)	5
TX Alternate Busy Tone (TX ABTON)	5
TX GE-MARC Tone (TX GMARC)	5
Tone Set Select (TONE SEL)	5
DTMF Tone (TX DTMF)	5
Decode Test (DECODE T)	5
Encode Test (ENCODE T)	5
Relay Switch (RELAY)	5
TEST PROCEDURE	6
TRANSMITTER VERIFICATION	6
Transmitter Frequency	6
Transmit Power	6
Audio Modulation Limiting	6
High Speed Data Check	6
Low Speed Data And Channel Guard Check	6
RECEIVER VERIFICATION	6
SINAD	6
Audio Output	6
High Speed Data Eye Pattern	6
TEST EQUIPMENT AND SERVICE AIDS	6
TRANSMITTER ALIGNMENT	6
Frequency Set	6
Audio Modulation Set	6
Transmitter Power Set	6
Low Speed Data and Channel Guard Check	7
RECEIVER ALIGNMENT	7
Frequency Set	7
IF Tuning	7
Quadrature Detector Adjustment	7
Receiver Audio Level	7
Squelch Adjust	7
POWER DISTRIBUTION	7
A+	7
ALIGNMENT PROCEDURE	7
SW A+	8
Regulated Voltages	8
RF Board	8
Audio/Logic Board	8
Front Cap Assembly (Display Board)	8
Audio Amplifier Board	8
AUDIO SIGNAL FLOW	8
Transmitter Audio	8
Receiver Audio	8
LOGIC SIGNAL FLOW	8
APPENDIX A. GE-MARC TONES	8

DESCRIPTION

This Service Section contains the information necessary for aligning and troubleshooting the Dual Format MDX 800 MHz Mobile Radio. In addition, information is provided for disassembling the radio and replacing surface mount components.

INITIAL ADJUSTMENT

After the radio has been installed as described in the Installation Manual, the following adjustments should be made by a certified electronics technician.

TRANSMITTER ADJUSTMENT

The transmitter has been adjusted at the factory and should require no readjustment. However, the antenna length should be adjusted for optimum VSWR, and the frequency and modulation measured and recorded for future reference. For complete transmitter alignment, refer to the Alignment Procedures.

RECEIVER ADJUSTMENT

No initial adjustments to the receiver are required. Refer to the Receiver Alignment Procedure when service is required.

RE-INSTALLATION

The radio is designed to operate in 12 volt, negative ground vehicles only. If the mobile radio is moved to a different vehicle, always check the battery polarity of the new vehicle system.

PREVENTIVE MAINTENANCE

To ensure high operating efficiency and to prevent mechanical and electrical failures from interrupting system operations, routine checks should be made of all mechanical and electrical parts at regular intervals. Preventive maintenance should include the following checks.

CONNECTIONS

Ground connections to the voltage source should be periodically checked for tightness. Loose or poor connections to the power source will cause excessive voltage drops and faulty operation. When ground connections are not made directly to the battery, the connection from the battery to vehicle chassis must be checked for low resistance. A high resistance may cause excessive voltage drops and alternator noise problems.

ELECTRICAL SYSTEM

Check the voltage regulator and alternator or generator periodically to keep the electrical system within safe operational limits. Overvoltage is indicated when the battery loses water rapidly. Usage of 1 or 2 ounces of water per cell per week is acceptable for batteries in continuous operation. A weak battery will often cause excessive noise or faulty operation.

MECHANICAL INSPECTION

Since mobile units are subject to constant shock and vibration, check for loose plugs, nuts, screws and other parts to make sure that nothing is working loose.

ANTENNA

The antenna, antenna base and all contacts should be kept clean and free from dirt or corrosion. If the antenna or its base should become coated or poorly grounded, loss of radiation and a weak signal will result.

ALIGNMENT

The transmitter and receiver meter readings should be checked periodically and the alignment optimized when necessary. Refer to the Alignment Procedure.

FREQUENCY CHECK

Check transmitter frequency and deviation. Normally, these checks are made when the unit is first placed in operation, after the first six months, and once a year thereafter.

STATIC HANDLING PRECAUTIONS

This radio contains Metal Oxide Semiconductor (MOS) devices which are vulnerable to damage from Electrostatic Discharge (ESD). As a result, extra care must be taken when handling or testing the devices, modules, or the assemblies in which they are used.

To prevent damage from ESD, observe the following precautions:

- Service the radio only at a static free work station or on a grounded mat.
- Perform diagnostics to isolate a faulty assembly or component. Do not use canned coolant for fault isolation.
- Discharge static voltage from your body by wearing a grounded antistatic wrist strap where possible. Where ground straps can not be used, touch a grounded item prior to handling an open radio.

- Avoid touching any electrically conductive parts of circuit modules with your hands. When you must handle components, pick them up by the body and avoid touching the leads.
- Do not remove static sensitive devices from their protective packaging until you are ready to install them. Ground the package, to dissipate any accumulated charge, prior to removing the component.
- Ground all electrically powered test equipment. Ground test equipment leads prior to connecting to a circuit and connect the ground lead prior to connecting the test probe. Disconnect the probe before removing the ground lead.
- When soldering, be sure soldering iron is grounded using a three prong cord connected to an outlet with a known good earth ground.
- Use only metallized or ESD protective vacuum-type desoldering tools.

NOTE

This symbol is used to identify circuitry using Electrostatic sensitive devices. Be sure to follow Static Handling Procedures when working near these devices.

DISASSEMBLY PROCEDURES

Disassembly procedures are provided to completely disassemble the radio. In general, reassembly is in the reverse order. Included are procedures to remove the top and bottom covers, RF board, audio/logic board, system board, PA board, and front cap assembly including the audio amplifier board and display board. Refer to Assembly Diagrams located in rear of this section when assembling or disassembling the radio or replacing component boards.

NOTE

Remove power from the radio before servicing.

TO REMOVE BOTTOM COVER

1. Remove the four screws securing the bottom cover to the radio.
2. Gently lift the bottom cover from the radio.

TO REMOVE TOP COVER

1. Remove the bottom cover and slide the top cover up out of the casting.

NOTE

When replacing the covers check to see that the "O" ring gaskets are properly seated in the cover grooves. Also make sure the cables are pressed down in the inner wall slots so they will not be pinched during reassembly.

TO REMOVE RF BOARD A2

1. Remove the top and bottom covers from the radio.
2. Pry off the friction fit covers covering the RF board.
3. Gently pry interconnect plug P702 from the logic and RF boards using a small standard screwdriver.
4. Remove the two clips securing Q101 and U102 to the frame (on top side of board).
5. Remove the two M3.5-0.6 x 20 TORX screws (#15 drive) securing PA module U101 to the frame.
6. Remove the six M3.5-0.6 x 8 TORX screws (#15 drive) from the bottom side of the board.
7. Disconnect wires attached to J704, J705 and cables going to the PA Board.
8. Remove the six spring clips protruding through the RF board from the bottom side.
9. Gently push the RF board out of the radio casting.

TO REMOVE THE FRONT CAP ASSEMBLY

1. Remove the top and bottom covers of the radio.
2. Remove the four TORX screws (#10 drive) from top and bottom of the front cap assembly.
3. Gently pull the front cap assembly away from the radio.
4. Disconnect the ribbon cable from the rear of the assembly and disconnect the speaker leads from the system board. The front cap assembly can then be removed from the radio.

NOTE

When replacing the front cap assembly on the radio casting first check that the "O" ring gasket is seated in the casting groove. Carefully press the front cap over the gasket making sure the gasket remains in the groove. Reinstall the 4 TORX screws while applying pressure to seat the front cap against the casting.

TO REMOVE AUDIO AMPLIFIER BOARD A3

1. Remove the top and bottom covers.
2. Remove front cap assembly.
3. Remove the four M3.5-0.6 x 8 TORX screws (#15 drive) securing the audio amplifier board to the radio casting.
4. Disconnect the interconnecting cable between the audio amplifier board and the system and display boards.
5. Lift the audio amplifier board out of the front cap assembly.

TO REMOVE AUDIO/LOGIC BOARD A1

1. Remove the top cover, bottom cover, front cap assembly and the audio board from the radio. Refer to the disassembly procedures for each.
2. Remove interconnect plug P702 from the RF and audio/logic board on the bottom of the radio.
3. Remove the four M3.5-0.6 x 8 TORX screws (#15 drive) securing the audio/logic board to the radio frame.
4. Carefully work the audio/logic board out of the radio, being careful not to damage the plug going to the front cap assembly.

TO REMOVE SYSTEM BOARD A5

1. Remove radio bottom cover.
2. Disconnect the speaker leads from J904.
3. Disconnect the ribbon cable from J902.
4. Disconnect the option cable, if used.
5. Remove the three M3.5-0.6 x 8 TORX screws (#15 drive) securing the system board to the frame.
6. Carefully work the board out of the radio, unplugging it from feed through assembly Z903.

PA BOARD REMOVAL

1. Remove the top and bottom covers of the radio as instructed above.

NOTE

When installing the PA Board in the radio, tighten the screws securing the board to the casting to 15 inch-pounds. Then install the screws securing the transistor and torque to 4.5 inch-pounds.

2. Disconnect the cables to the RF board.
3. Disconnect the cable at J151 on the PA board.
4. Remove the two M2.5-0.45 TORX screws (#8 drive) securing the PA transistor to the frame.
5. Remove the four M3.5-0.6 TORX screws (#15 drive) securing the board to the frame. Carefully work the board out of the radio, unplugging it from the feed through assembly Z903.

TO REMOVE THE DISPLAY BOARD

1. Remove the top and bottom covers and front cap assembly as directed above.
2. Remove the seven M3.5-06 x 8 TORX screws (#15 drive) from the rear of the front cap assembly to remove the two brackets and center of display board.
3. Gently pull the control panel away from the front cap and disconnect the ribbon cable on the rear of the panel.

COMPONENT REPLACEMENT**SURFACE MOUNTED COMPONENTS**

Surface mounted "Chip" components should always be replaced using a temperature controlled soldering system. The soldering tools may be either a temperature controlled soldering iron or a temperature controlled hot-air soldering station. A hot-air system is recommended for the removal of components on multi-layer boards. With either soldering system, a temperature of 700°F (371°C) should be maintained.

The following procedure outlines the removal and replacement of surface mounted components. If a hot-air soldering system is employed, see the manufacturer's operating instructions for detailed information on the use of your system.

CAUTION

Avoid applying heat to the body of any chip component when using standard soldering methods. Heat should be applied only to the metallized terminals of the components. Hot-air systems do not damage the components since the heat is quickly and evenly distributed to the external surface of the component.

CAUTION

This unit contains many static sensitive components, observe static handling precautions during any service procedure.

apply heat for an excessive length of time and do not use excessive solder.

With a hot-air system, apply hot air until all "tinned" areas are melted and the component is seated in place. It may be necessary to slightly press the component down on the board. Touch-up the soldered connections with a standard soldering iron if needed. Do not use excessive solder.

4. Allow the component and the board to cool and then remove all flux from the area using alcohol or other EGE approved flux remover.

CAUTION

Some chemicals may damage the internal and external plastic and rubber parts of the radio.

To Remove Surface Mounted Components

1. Grip the component with tweezers or small needle nose pliers.
2. Alternately heat the metallized terminal ends of the chip component with the soldering iron. If a hot-air system is used, direct the heat to the terminals of the component. Use extreme care with the soldering equipment to prevent damage to the printed wire board (PWB) and the surrounding components.
3. When the solder on all terminals is liquefied, gently remove the component. If all solder is not completely liquefied, the use of excessive force may cause the PWB pads to separate from the board.
4. It may be necessary to remove excess solder using a vacuum de-soldering tool or Solderwick®. Again, use great care when de-soldering or soldering on the printed wire boards. It may also be necessary to remove the epoxy adhesive that was under the chip component and any flux from the printed wire board.

To Replace Surface Mounted Components

1. "Tin" all terminal ends on the new component and on the pads of the PWB. Use as little solder as possible.
2. Place the component on the PWB pads, observing proper orientation for capacitors, diodes, transistors, etc.
3. Simultaneously touch the "tinned" terminal end and the "tinned" pad with the soldering iron. It may be necessary to slightly press the component down on the board. Repeat this procedure on all component terminals as necessary. Do not

To Replace Surface Mounted Integrated Circuits

Soldering and de-soldering techniques of the surface mounted IC's are similar to the procedures for the surface mounted chip components. Use extreme care and observe static precautions when removing or replacing the defective (or suspect) IC's. This will prevent any damage to the printed wire board or the surrounding circuitry.

Replacement of the surface mounted IC's is best completed using a hot-air soldering system. See the manufacturers instructions for complete details on tip selection and other operating instructions unique to your system.

If a hot-air system is not available, the service technician may wish to clip the leads near the body of the defective IC and remove it. The leads can then be removed from the PWB using a standard soldering iron and tweezers. Install the new IC following the Chip Component Replacement procedures. It may not be necessary to "tin" the IC leads before the installation process.

TROUBLESHOOTING PROCEDURES

This section should help isolate a problem to a particular board or circuit. Block diagrams for power distribution, audio signal flow, and logic flow are located at the back of this manual. Refer to the appropriate LBI on the suspect board for additional circuit information.

The Dual Format MDX 800 MHz mobile radio is divided into 6 boards for assemblies. To aid in identifying the suspect board, major functions for each board are given below. Refer to the appropriate LBI on each for more details.

- RF Board A2: Synthesizer: generates all transmit and receive frequencies.
Receiver: provides detected audio to the audio board.
Transmitter: includes exciter and 10 watt PA Module.
Power control circuitry for the transmitter.
Lowpass filter for the transmitter.
- PA Board A4: Power amplifier: amplifies the 10 watt output of the RF board to 25 watts.
- Audio/Logic Board A4: Analog filtering of the RX and TX audio (voice, low speed data, high speed data, and signalling tones).
RX squelch processing.
Conventional analog tone filtering and processing.
Signal routing between the RF, audio amplifier, and display boards.
EEPROM for the radio personality.
The main radio microprocessor.
Accepts PTT from the microphone.
Provides DPTT to turn on the transmitter.
Provides synthesizer channel data to the RF Board.
Generates and detects the Channel Guard tones and data.
Generates and detects high speed and low speed data.
Generates and detects GE-MARC busy tones.
Generates and detects GE-MARC signalling tones.
- System Board A5 A+ switching circuitry.
Option connections.

- Front Cap Assembly Control Panel.
Display Board includes microprocessor and display.
Speaker.

ERROR MESSAGES

During normal operation, the following error messages could appear:

- SYN LOCK - occurs when the synthesizer is unable to lock on frequency.
- E9 - indicates that no personality is programmed into the radio.
- E1 - is displayed when the Group/Version number is displayed to indicate that invalid operational code is loaded into the radios FLASH memory.

SYMPTOMS AND CHECKS

SYMPTOMS	CHECKS
Blank display on power up	Check for dc voltages to J707 on the display board. Check for A & Sw and 8 Volts on J702.

NOTE

If no conventional or GEMARC systems are programmed and Encryption Not Valid, the display will be blank.

Radio will not go into test mode	The radio must be PC programmed to enable the test mode. Enable it on the options screen.
Low, distorted, or no RX Audio	Check the receiver VOL/SQ HI output. The problem is most likely in the RF board. If the synthesizer load commands are not correct, the problem may be on the audio/logic board. If the audio is correct at VOL/SQ HI, check the RX audio out. If improper check the audio/logic and/or audio amplifier boards for proper unmute commands. Proper commands indicate a faulty audio/logic or audio amplifier board.

No RX Alert Tone	Check the signalling tone output from the audio/logic board. Operate the volume control. If tones are not present, the audio/logic board may be faulty.	Radio will not program when plugged into the TQ3310 or TQ3370 interface module	Verify radio is getting turned "on" by programmer.
Poor RX	Suspect the RF board. Check Sensitivity and receiver alignment. Refer to the RF board maintenance manual.	Distorted TX Audio	Check grounding between all boards and the casting. Check the TX mod input to the RF board. If distorted, a faulty audio/logic board is likely.
No TX Power	Check the DPTT command to the RF board. If present, then the problem is likely on the RF board. If the DPTT is not present, the problem is likely on the audio/logic board.		Check the mute commands. If incorrect a faulty audio/logic board is likely.
Low TX Power	Check the transmit frequency. If its not OK, check the synthesizer on the RF board load commands from the audio/logic board. If the commands are not present, a problem in the audio/logic board is likely. If the TX frequency is correct, refer to the maintenance manual for the RF board and troubleshoot the transmitter.	Transmitter Off Frequency	Suspect the RF board. Refer to "Frequency Set" procedure in the Transmitter Alignment section of this manual. Check the synthesizer load command. If the load command is wrong, a faulty audio/logic board is likely.
No TX Modulation	Check the TX MOD input to the RF board. If present, the RF board may be faulty. If not present, determine what is missing: tone, voice, or both. Missing tones - Look for the signalling tone and busy tone on the audio/logic board. If the tones are not present, the audio/logic board may be faulty. Tones present - look for the proper unmute commands on the audio/logic board. If the commands are not present, the audio/logic board may be faulty. Missing Voice Signal - Check the mute commands on the audio amplifier board and the TX Audio input. If all signals are correct, the problem is likely a faulty audio/logic board. If no signal is present at the audio/logic board, check the output from the audio amplifier board and the microphone outputs.	Calls Processed Incorrectly	Check personality PROM programming. Check for proper TX and RX operation. Refer to TX and RX Verification Procedures. If verification OK, determine if the problem is in the transmit or receive circuit. RX decode check: Use the decode T test mode command. Modulate the generator with the correct tone sequence and busy tone. If the test fails, check the limited data output from the audio/logic board. If the data is not present, the audio/logic board may be faulty. TX encode check: Use the encode test. If the test fails, the audio/logic board may be faulty. Look for the proper tones on the audio/logic board and proper unmute commands. If all inputs are correct, the board may be faulty. TX/RX/Encode/Decode OK: Check proper synthesizer switching time. Use BAND SWT test. If the switching time is incorrect, the RF board may be faulty.

TEST PREPARATION

Field test mode can be disabled via the PC programmer. If enabled, the following describes the "User Testmode" that is employed by the Dual Format MDX radio.

It is recommended that the users test frequency set include at least 4 conventional channels with one of the channels being a talk-around channel.

TEST MODE COMMANDS

At any time during the test if "TESTSET?" is displayed then there is no Test Set programmed to perform the test. If "TONE-SET?" is displayed then there is no GE-MARC tone set programmed to perform the test. At this point you will have to PC program your radio with a Test/Tone Set to execute the desired test. The suggested personality frequency test will contain at least four frequency sets, preferably with one of the frequency sets containing a talk-around frequency.

Test mode enables the technician to exercise test functions in the field using the radios standard user interface (i.e. front cap assembly). To enter the test mode the user must:

- 1) Press the **SYSTEM** and microphone **PTT** buttons while powering up the radio.
- 2) When test mode is first entered "TESTMODE" appears in the display. Once in test mode the user may step through the various commands by pressing the **Volume Up/Down** button.

Once the desired test has been selected with the volume buttons the **MNU** key must be pressed to activate the selected test.

The selected commands are:

- Default Set-up (DEFAULT)
- Set Channel Test (SET CHAN)
- Volume Control (VOLUME)
- Key/Unkey Transmitter (XMIT CON)
- Mute/Unmute Receiver Audio (AUDIO CON)
- Mute/Unmute Mic Audio (PHON CON)
- Generate Dotting (4800 CPS)
- Generate Pseudo Random HS Data (9600 PRD)
- Encode Channel Guard Tone (150 CPS)
- Report Receiver Carrier Sense (CAS TEST)
- Across Band Switching (BAND SWT)
- Generate Alert Tone (ALERT TN)

- External RAM Test (RAM TEST)
- Software Version Number (UPR)
- Checksum Test (PROG TS)
- 11 Hertz (11 HERTZ)
- TX Standard Busy Tone (TX BSYTN)
- Tone Set Select (TONE SEL)
- DTMF Tone (TX DTMF)
- Decode Test (DECODE T)
- Encode Test (ENCODE T)
- Relay Switch (RELAY)

Key/Unkey Transmitter (XMIT CON)

Selecting the "XMIT CON" menu selection allows the user to toggle the state of the transmitter; "XMIT ON" or "XMIT OFF". Press the **MNU** button to display the last state of the transmitter. Use the **GROUP UP/DOWN** buttons to toggle to the desired state of the transmitter - on/off. Press the **MNU** button to exit the transmit control mode, leaving the transmitter in the last state selected.

Mute/Unmute Receiver Audio (AUDI CON)

The "AUDI CON" menu selection displays the state of the audio; "AUDIO ON" or "AUDIO OFF". Press the **MNU** button to display the last state of the audio. Use the **GROUP UP/DOWN** button to toggle the audio on/off. Press the **MNU** button to exit the audio control mode, leaving the audio in the last state selected.

Mute/Unmute Mic Audio (PHON CON)

Selecting the "PHONO CON" menu selection indicates the current microphone audio state; "PHON ON" or "PHON OFF". Press the **MNU** button to display the last state of the microphone audio. Use the **GROUP UP/DOWN** button to toggle the microphone on or off. Press the **MNU** button to exit the microphone control mode, leaving the microphone in the last state selected.

Generate Dotting (4800 CPS)

This command causes the radio to begin generating a "dotting" (i.e. "10101010") pattern using its modem chip at 9600 baud (4800 Hz signal). To modulate the transmitter with this pattern, the transmitter must have been keyed using the "Key Transmitter" command.

Select the "4800 CPS" menu selection. Press the **MNU** button. The display flashes indicating the signal is being generated. The pattern will continue until another button is pressed.

Generate Pseudo Random HS Data (9600 PRD)

This command causes the radio to begin generating pseudo random data using its modem chip. This data will be sent at 9600 baud. To modulate the transmitter with this data, the transmitter must have been keyed using the "key transmitter" command.

Select the "9600 PRD" menu selection. Press the **MNU** button to begin test. The display flashes indicating the signal is being generated. The pattern will continue until another button is pressed.

Encode Channel Guard Tone (150 CPS)

This command causes the radio to generate a subaudible CG tone at 150 cps. To modulate the transmitter with this tone, the transmitter must have been keyed using the "key transmitter" command.

Select the "150 CPS" menu selection. Press the **MNU** button to begin the test. The display flashes indicating the signal is being generated. Press any button to terminate the test tone.

Report Receiver Carrier Sense (CAS TEST)

This command causes the radio to indicate opening/closing squelch on its display.

Select the "CAS TEST" menu selection. Press the **MNU** button to display the state of the CAS signal, either "RCV SIG" or "NO SIG". The radio monitors the signal and displays any changes in the CAS signal. Pressing any button terminates the test.

Across Band Switching (BAND SWT)

This command causes the radio to switch the synthesizer between personality channels 1 and 4 at approximately 2 second intervals.

Select the "BAND SWT" test from the menu. Press the **MNU** button and the display will alternate between "CHAN 1" and "CHAN 4" as the channels are changed. Press any button to terminate the test.

Generate Alert Tone (ALERT TN)

This command causes the radio to sound a beeping 528 Hz tone to test the alert tone audio paths.

Select the "ALERT TN" test from the menu. When the **MNU** button is pressed, the display flashes indicating the tone is active. Pressing any button terminates the test.

External RAM Test (RAM TEST)

This test causes the radio to conduct a test of its 8K RAM chip.

Select the "RAM TEST" command from the menu. Press the **MNU** button; the display indicates either "RAM PASS" or "RAM FAIL", depending on the test results.

Software Version Number (UPR)

This command displays the software version number.

Checksum Test (PROG TS)

This command causes the radio to conduct a checksum test of its program memory.

Select "PROG TS" from the menu. Press the **MNU** button to execute the test. The display shows either "PRG PASS" or "PRG FAIL" based on the results.

Default Set-up (DEFAULT)

This command causes the radio to revert to the default settings. The radio turns off the transmitter, disables the transmit audio, and sets the ASP back to its power-up state.

Select the "DEFAULT" command. Press the **MNU** button and the display changes to "TESTMODE" indicating the default set-up has occurred.

Set Channel (SET CHAN)

This command causes the radio to select one of the channels on the test mode frequency set that is in the current personality.

Select the "SET CHAN" command from the menu. Press the **MNU** button to display the channel selection. Pressing the **GROUP UP/DOWN** buttons scroll through the channel selections. Pressing any button terminates the test.

Volume Control (VOLUME)

This command enables you to adjust the volume control of the ASP (audio signal processor IC).

Select the "VOLUME" command from the menu. Press the **MNU** button and the display flashes, indicating the test is in progress. Pressing the **Volume Up/Down** buttons increments or decrements the volume level by one step. Press the **MNU** button to terminate the test.

11 Hertz Test (11 HERTZ)

This command generates an 11 Hz square wave on the low speed data (Channel Guard) output. To modulate the transmitter with this data, the transmitter must have been keyed using the "key transmitter" command.

Select the "11 HERTZ" test from the menu. Press the **MNU** button; the display flashes indicating the signal is being generated. Press any key to terminate the test.

TX Standard Busy Tone (TX BSYTN)

This command generates a standard GE-MARC busy tone. To modulate the transmitter with this data, the transmitter must have been keyed using the "key transmitter" command.

Select the "TX BSYTN" command from the menu. Press the **MNU** button; the display will begin flashing to indicate a standard busy tone is being generated. Press any key to terminate the test.

TX Alternate Busy Tone (TX ABTON)

This command is used to generate an alternate GE-MARC busy tone. To modulate the transmitter with this data, the transmitter must have been keyed using the "key transmitter" command.

Select the "TX ABTON" command from the menu. Press the **MNU** button; the display will begin flashing to indicate an alternate busy tone is being generated. Press any key to terminate the test.

TX GE-MARC Tone (TX GMARC)

This command causes the radio to transmit the user specified GE-MARC tone.

Select the "TX GMARC" command from the menu. Press the **MNU** button to display the GE-MARC tone. Pressing the **GROUP UP/DOWN** key scrolls through the possible GE-MARC tone selections. To modulate the transmitter with this data, the transmitter must have been keyed using the "key transmitter" command. See Appendix A for a listing of the GE-MARC tones.

Tone Set Select (TONE SEL)

This command causes the radio to select a channel in the user specified GE-MARC test mode tone set.

Select the "TONE SEL" command from the menu. Press the **MNU** button to display the tone set. Pressing the **GROUP UP/DOWN** button scrolls through the tone set selections. Press the **MNU** button to terminate the selection. This selection is then retained until a new tone set is selected (not retained once test mode is exited). To modulate the transmitter with this data, the transmitter must have been keyed using the "key transmitter" command.

DTMF Tone (TX DTMF)

This command causes the radio to transmit the selected DTMF tone (0-9,*,#).

Select the "TX DTMF" command from the menu. Press the **MNU** button to display the selected DTMF tone. Pressing the **GROUP UP/DOWN** button scrolls through the possible selections. Press the **MNU** button to terminate the test. To modulate the transmitter with this data, the transmitter must have been keyed using the "key transmitter" command.

Decode Test (DECODE T)

This command causes the radio to attempt to decode a GE-MARC tone set. The call is looked for on the currently selected channel (SET CHAN) using the currently selected tone set (TONE SEL).

Select the "DECODE T" command from the menu. Press the **MNU** button; the radio immediately begins attempting to decode the selected tone set and continues until either it is decoded (at which time "DEC COMP" is displayed) or the user terminates the function by pressing any key.

Encode Test (ENCODE T)

This command causes the radio to transmit a tone set. The call is originated on the currently selected channel (SET CHAN) using the currently selected tone set (TONE SEL).

Select the "ENCODE T" command from the menu. Press the **MNU** button; the radio will initiate the test and once completed "ENC COMP" will be displayed. To modulate the transmitter with this data, the transmitter must have been keyed using the "key transmitter" command.

Relay Switch (RELAY)

This command causes the relay (external alarm) line to toggle once each second.

Select the "RELAY" command from the menu. Press the **MNU** button; the display begins flashing to indicate the relay line is being pulsed. Press any key to terminate the test.

TEST PROCEDURE

TRANSMITTER VERIFICATION

Place the radio in test mode operation for the following tests by pressing the **SYSTEM** button and microphone **PTT** switch when powering up the radio.

When test mode is first entered "TESTMODE" appears in the display.

Once the desired test has been selected with the volume buttons the **MNU** key must be pressed to activate the selected test.

Transmitter Frequency

Key the transmitter on any channel and measure the transmit frequency. The measured frequency should be within 250 Hz of the assigned channel frequency.

Transmit Power

Select a channel and key the transmitter. Measured power should be 25 watts 0.5 dB. Current should be less than 11 amperes.

Audio Modulation Limiting

1. Apply a 1 kHz tone at 1.0 Vrms to the MIC HI input at TQ3310 or TQ3370.
2. Select a channel. Turn on TX audio (no Channel Guard or low speed data). Measure and note deviation.
3. Select another channel. Measure the deviation. The highest measured deviation on the two channels should be 3.5 kHz \pm 0.2 kHz.

High Speed Data Check

1. Check high speed dotting data. TX data deviation should be 3.0 kHz \pm 0.2 kHz.

Low Speed Data And Channel Guard Check

1. Check TX audio with low speed data. TX audio deviation should be 4.25 kHz \pm 0.25 kHz.

RECEIVER VERIFICATION

SINAD

1. Apply an on-channel RF signal to the antenna jack. Modulate the signal with a 1 kHz tone at 3 kHz deviation. Set the RF level to -116 dBm.
2. Check for greater than 12 dB SINAD on-channel at the RX Audio output, on the TQ3310 or external speaker leads of option connector J905-2,9 (see Figure 1).
3. Repeat the test for the band ends and the center channel frequency.

Audio Output

1. Apply a strong (-50 dBm) on-channel signal modulated with a 1 kHz tone at 3 kHz deviation.
2. Monitor option connector J905-2,9 and adjust volume for 10 watts output (6.3 Vrms into 4 ohms). Distortion should be less than 5%. **NOTE: The 10 watt PA has "balanced outputs" and must be tested with the test setup shown in Figure 1.**

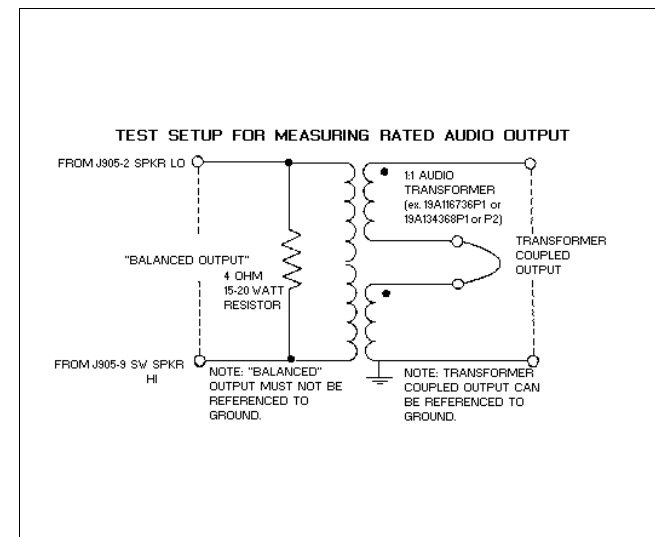

Figure 1 - Audio Output Test Setup

High Speed Data Eye Pattern

1. Input a companion radio high speed dotting data TX output in the antenna port at 25 milliwatts. Verify an optimum receive eye pattern on the VOL/SQ HI line at J705-3. A typical Eye Pattern is shown in Figure 2.

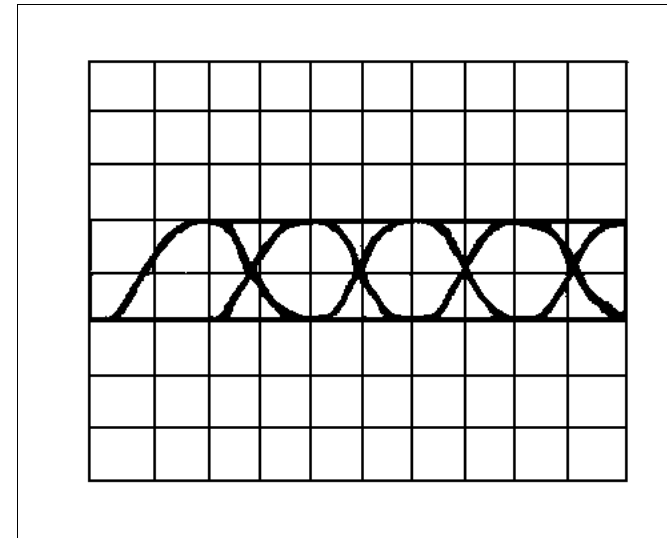

Figure 2 - High Speed Data Eye Pattern

TEST EQUIPMENT AND SERVICE AIDS

The following list of test equipment and service aids are available to facilitate servicing.

- TQ3370 PC Programming Adapter - includes 19D438367G1 Programming Interface Box w/LBI-31986, cable 19B235027P1 (interface to PC Computer), and Power Supply 19B800850P2
- TQ3310 **NOTE:** The TQ3310 can be used for PC programming to test but TQ3370 is required for flash programming.
- TQ3371 Programming cable - interface to Dual Format MDX Series radios
- 19A705235P2 Service cable - provides a two foot extension between the system and control boards. Not required for most servicing if existing cable is not looped through the front of the radio assembly.
- 19A801348P4 Provides a two foot extension between the 9-pin "D" connectors on the audio/logic and control boards. Permits servicing all assemblies in the audio amplifier while power is applied.
- ST3712 Pin Extractor Tool (11-03- 0038) Allows removal of contacts from connector shell that mates with Option Cable CC01. The

Option Cable is required with all external options.

- ST2513 Alignment Tool - with two ceramic tips - used for squelch control and other adjustments.
- ST2617 Crimping Tool for field attachment of TNC - series male connectors 19A115903P1 to RG-58/U (and similar) coaxial cable.

TRANSMITTER ALIGNMENT

Frequency Set

Select any channel frequency. Key the transmitter and measure the transmit frequency. The frequency should be within \pm 250 Hz of the channel frequency. If not, adjust U204 to within \pm 100 Hz.

Audio Modulation Set

NOTE

The temperature should be $25^{\circ} \pm 5^{\circ}$ C. Ensure frequency counter calibration is better than \pm 0.1 PPM.

1. Apply a 1 kHz, 0.3 Vrms signal to the MIC HI input at TQ3310 and TQ3370. Note that MIC HI has a DC voltage present.
2. Turn on the TX audio (with Channel Guard or low speed data). Key the transmitter on a channel near the center of the frequency band (806-825). Adjust modulation control R254 for 4.75 kHz \pm 0.2 kHz deviation.
3. Key the transmitter on a channel near the center of the frequency band in the direct mode and adjust R226 for 4.25 kHz \pm 0.2 kHz deviation.
4. Repeat steps 1-3 for a midband talk-around channel (851-870) and adjust R226.

Transmitter Power Set

1. Key the transmitter and adjust R111 in the power control circuit for 25 watts.

ALIGNMENT PROCEDURE

To align the radio, test mode operation should be used as described in the Test Preparation section. Refer to the assembly diagrams for board location and to Figure 3 for adjustment and test point locations.

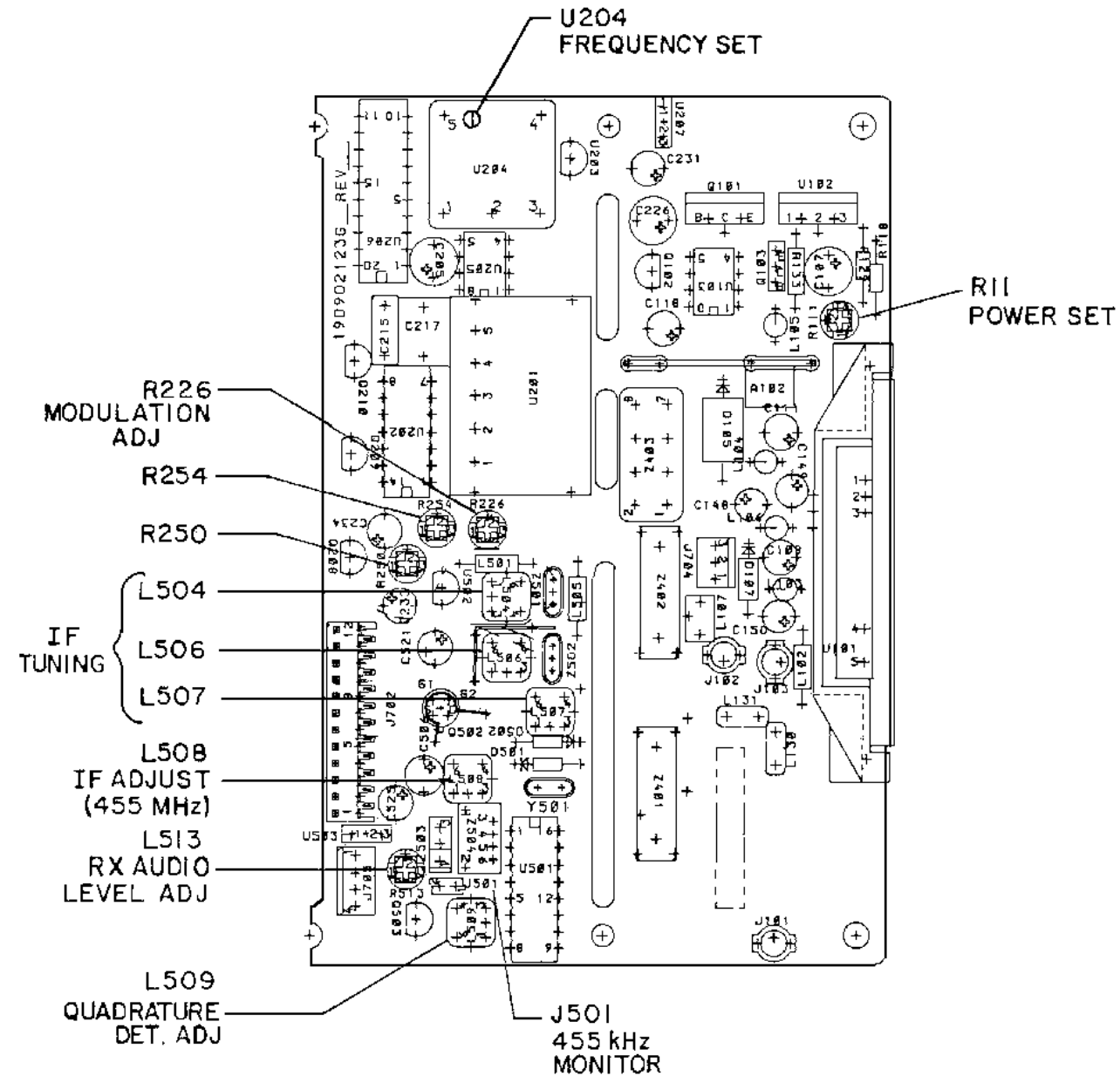

Figure 3 - Location Of Controls And Adjustments, RF Board

Low Speed Data and Channel Guard Check

1. Turn on the 11 Hz signal (low speed data). Verify TX modulation is $0.75 \text{ kHz} \pm 0.25 \text{ kHz}$. Adjust R250 for minimum deviation.
2. Turn on 150 cps data and verify transmit modulation is $750 \pm 0.25 \text{ kHz}$.

RECEIVER ALIGNMENT

Frequency Set

1. Verify that the transmitter is on frequency as described in the transmitter alignment procedure.
2. Inject a strong on-channel signal (-50 dBm) at the antenna input J101.
3. Monitor J501 with a frequency counter and adjust L508 for a reading of $455 \text{ kHz} \pm 100 \text{ Hz}$.

IF Tuning

1. Monitor J501 pin 1 with an AC voltmeter (pin 2 is ground). Inject an on-channel signal at the antenna jack modulated with a 1 kHz tone at 3 kHz deviation.
2. Adjust L504, L506, and L507 for a peak on the voltmeter. Adjust the level of the generator to keep the signal at J501 out of limiting (approximately -65 dBm)
3. Repeat the coils.

Quadrature Detector Adjustment

1. Inject a strong (-60 dBm) on-channel signal at the antenna jack modulated with a 1 kHz tone at 3.0 kHz deviation.
2. Monitor the VOL/SQ HI output at J705-3 with an AC voltmeter and adjust L509 for a peak indication on the meter.

Receiver Audio Level

1. Inject a strong on-channel signal at the antenna jack modulated with a 1 kHz tone at 3.0 kHz deviation.
2. Monitor VOL/SQ HI at J702-4 on the audio board with an AC voltmeter. Adjust R513 on the RF board for a reading of $1.5 \pm 0.1 \text{ Vrms}$.

Squelch Adjust

1. Select any channel. Apply a signal modulated with a 1 kHz tone at 3.0 kHz deviation to the antenna jack.
2. Press and hold the **SCAN** button on the radio and use the **Volume Up/Down** to open/close the squelch.
3. While monitoring SPKR HI J725-3, adjust the signal generator for 8 dB SINAD.
4. While holding the **SCAN** button press the Volume Down button until you hear a pop (squelch fully closed). Now press the Volume Up button until the squelch just opens.
5. Check adjustment by turning signal generator RF level down slowly until squelch closes. Slowly bring RF level back up. Squelch should open at 8 dB SINAD.

POWER DISTRIBUTION

Refer to the Power Distribution Block Diagram for an understanding of the distribution of A+, SW A+, and the regulated voltages throughout the radio.

A+

A+ (+13.8 volts nominal) enters the radio on the power cable and is connected to the system board. A+ feeds MOSFET switch Q903 which provides SW A+ power to the audio amplifier board through A5 J902 and A6 J901. A+ is also applied to the display board through A6 J707 and P707 on the display board.

A+ leaves the system board on J903 and feeds the PA board and RF transistor Q151 through feedthru capacitor assembly Z903. D905 on the system board provides reverse polarity protection for the radio. D904 provides overvoltage positive spike protection on the system board A+ lead. A+ leaves the board on J151 and supplies power to PA module U101 and Q101 on the RF board. Q101 supplies the power control voltage to the PA module.

SW A+

Switched A+ (13.6 volts nominal) originates from the MOSFET switch on the system board. The Ignition Sense lead and the **POWER** push-button control the MOSFET switch. Fuse F901 protects the MOSFET and the radio from high current failures. SW A+ is supplied through J902 and J903 to the front cap assembly. It provides power to the 5 volt regulator, 10 watt audio PA, and the front cap display board. J903 provides SW A+ to the PA board which, in turn, passes SW A+ through A4 J151 and A2 J705 to the RF board.

SW A+ enters the RF board on J704 and J705 and supplies power to three 8-volt regulators and the transmitter power control circuitry. SW A+ leaves the RF board on A2 J702 to supply power to 8-volt regulator U805 on the audio/logic board.

Regulated Voltages

SW A+ is the source of power for all voltage regulators. Several 5 volt regulators receive power from an 8-volt regulator reducing the power dissipated by the 5-volt regulators.

RF Board

8-volt regulator U502 provides power to the receiver. A separate 8.3-volt regulator U207 and 5-volt regulator U203 provide power to the synthesizer. 8 volt regulator U102 provides power to the transmitter. The output of U102 is switched to the exciter and the power control circuit. U503 powers the audio/logic board. U102 (TX 8-volt supply) and Q101 (power control output transistor) are mounted for heat sinking.

Audio/Logic Board

A 5-volt regulator, U801, is used to power the audio/logic board. The input voltage is derived from the 8-volt regulator on the RF board. The power-on reset circuitry for the audio/logic board microprocessor is part of regulator U801. This reset signal prevents scrambled operation due to low voltage transients during automobile starting. An 8-volt regulator is used to power the audio circuits.

Front Cap Assembly (Display Board)

A 5-volt regulator on the audio amplifier board powers the microprocessor logic display, icon LED's.

Audio Amplifier Board

A +5-volt regulator U727, is used for logic level pullups and to power the display board. SW A+ is used to power audio amplifier board U801, and display board backlighting control, Q850. An 8-volt regulator, U804, is used to power the operational amplifiers.

AUDIO SIGNAL FLOW

Refer to the Audio Signal Flow Block Diagram to see the distribution of RX and TX audio signals throughout the radio. Audio levels at important points are also shown.

Transmitter Audio

Microphone audio (MIC HI) is routed from the mic connector on the display board through the audio amplifier board to feed the audio/logic board. After processing and summing the Channel Guard tones, the audio (TX MOD) is fed through the audio/logic board to the RF board. TX MOD is adjusted by Deviation Adjust R226 before feeding the modulation input to the synthesizer VCO U201.

Receiver Audio

Discriminator audio is buffered by Q503 on the RF board and adjusted by R513. This audio (VOL/SQ HI) is routed to the audio/logic board for audio processing, tone/code detection, and volume control.

LOGIC SIGNAL FLOW

Refer to the Logic Signal Flow Block Diagram to see the distribution of logic signals throughout the radio.

APPENDIX A. GE-MARC TONES

NUMBER	FREQUENCY	NUMBER	FREQUENCY
01	604.2 Hz	22	1556.7 Hz
02	631.5 Hz	23	1628.3 Hz
03	662.3 Hz	24	1717.1 Hz
04	693.0 Hz	25	1795.6 Hz
05	727.1 Hz	26	1877.5 Hz
06	761.3 Hz	27	2051.6 Hz
07	795.4 Hz	28	2143.8 Hz
08	832.9 Hz	29	2239.4 Hz
09	870.5 Hz	30	2341.8 Hz
10	911.5 Hz	31	2447.6 Hz
11	952.4 Hz	32	2556.9 Hz
12	996.8 Hz	33	2672.9 Hz
13	1041.2 Hz	34	2792.4 Hz
14	1089.0 Hz	35	508.6 Hz
15	1140.2 Hz	36	529.1 Hz
16	1191.4 Hz	37	553.0 Hz
17	1243.0 Hz	38	576.9 Hz
18	1304.0 Hz	39	1962.9 Hz(acq)
19	1362.1 Hz	40	2918.7 Hz(alt)
20	1423.5 Hz	41	3051.9 Hz(std)

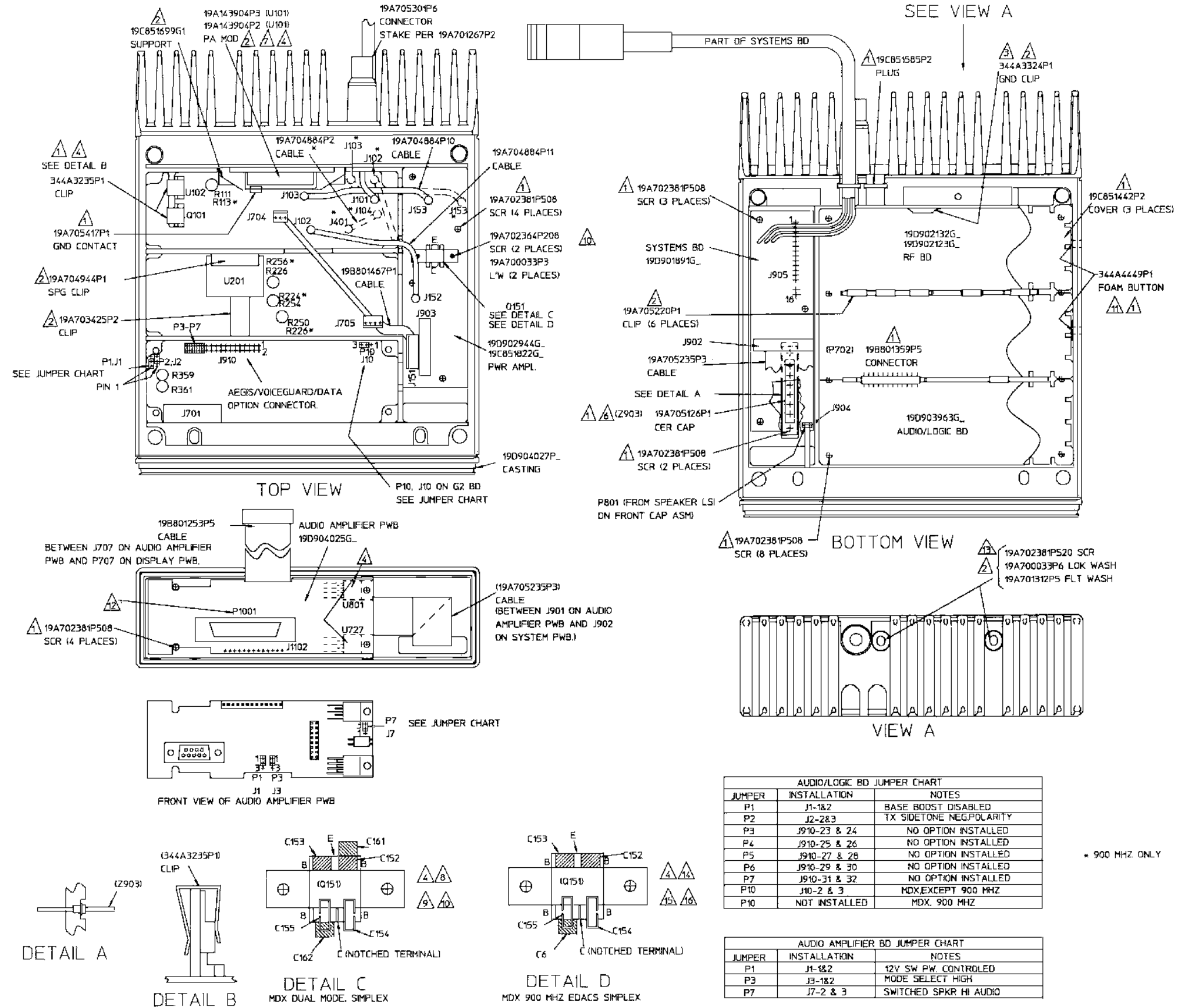

- ① MDX DUAL MODE, SIMPLEX
MDX 900 MHZ EDACS SIMPLEX
- NOTES:
- 1 PART OF MDX MARRIAGE HARDWARE KIT 344A4253G1.
 - 2 PART OF RF BD HARDWARE KIT 344A4255G6 (800MHZ).
PART OF RF BD HARDWARE KIT 344A4255G8 (900MHZ).
 - 3 INSTALL BETWEEN PWB AND CASTING SOLDER TO PWB.
 - 4 APPLY SILICONE GREASE (19A701337P1) TO PA MOD, Q101 AND U102 ON RF BD AND Q151 ON PA BD ALSO U801 AND U727 ON AUDIO AMPLIFIER BD.
 5. DIP ENDS OF SCREWS THAT GO INTO CASTING IN GREASE (19A115204P1) BEFORE INSTALLING INTO CASTING. TORQUE TO 15 INCH-POUNDS.
 - 6 LUBRICATE Z903 PINS WITH GREASE (19A704532P1).
 - 7 INSTALL U101 FLUSH TO PWB AND FASTEN WITH SUPPORT TO CASTING BEFORE SOLDERING LEADS TO PWB TOP OF U101 SHALL NOT EXTEND MORE THAN 0.25 ABOVE ADJACENT CASTING.
 8. PRE-TIN AREA AROUND Q151 WHERE TRANSISTOR LEADS AND C152 - C155, C161 AND C162 ARE TO BE SOLDERED.
 - 9 SOLDER Q151 LEADS WITH A MINIMUM OF SOLDER TO BD BEFORE INSTALLING CAPACITORS. SOLDER C152 - C155 AGAINST BODY OF Q151 ON TOP OF TRANSISTOR LEADS AS SHOWN BEFORE INSTALLING C161 AND C162 AGAINST C152 AND C155 AS SHOWN.
 10. PART OF PA BD KIT 344A4256G10 (800MHZ).
PART OF PA BD KIT 344A4256G12 (900MHZ).
 11. APPLY OVER TWO HOLES ON INSIDE OF CASTING.
 12. P1001 PART OF REMOTE MOUNT.
 13. WEATHERPROOF HOLES AROUND SCREWS USING RTV162 (19A701648P2).
 14. PRE-TIN AREA AROUND Q151 WHERE TRANSISTOR LEADS AND C152-C155 & C6 ARE TO BE SOLDERED.
 15. SOLDER Q151 LEADS WITH A MINIMUM OF SOLDER TO BD BEFORE INSTALLING CAPACITORS. SOLDER C152 - C155 AGAINST BODY OF Q151 ON TOP OF TRANSISTOR LEADS AS SHOWN BEFORE INSTALLING C6 AGAINST C155 AS SHOWN.
 16. PART OF PA BD KIT 344A4256G12.

AUDIO/LOGIC BD JUMPER CHART

JUMPER	INSTALLATION	NOTES
P1	J1-1&2	BASE BOOST DISABLED
P2	J2-2&3	TX SIDETONE NEG. POLARITY
P3	J910-23 & 24	NO OPTION INSTALLED
P4	J910-25 & 26	NO OPTION INSTALLED
P5	J910-27 & 28	NO OPTION INSTALLED
P6	J910-29 & 30	NO OPTION INSTALLED
P7	J910-31 & 32	NO OPTION INSTALLED
P10	J10-2 & 3	MDX, EXCEPT 900 MHZ
P10	NOT INSTALLED	MDX, 900 MHZ

AUDIO AMPLIFIER BD JUMPER CHART

JUMPER	INSTALLATION	NOTES
P1	J1-1&2	12V SW PW CONTROLLED
P3	J3-1&2	MODE SELECT HIGH
P7	J7-2 & 3	SWITCHED SPKR HI AUDIO

* 900 MHZ ONLY

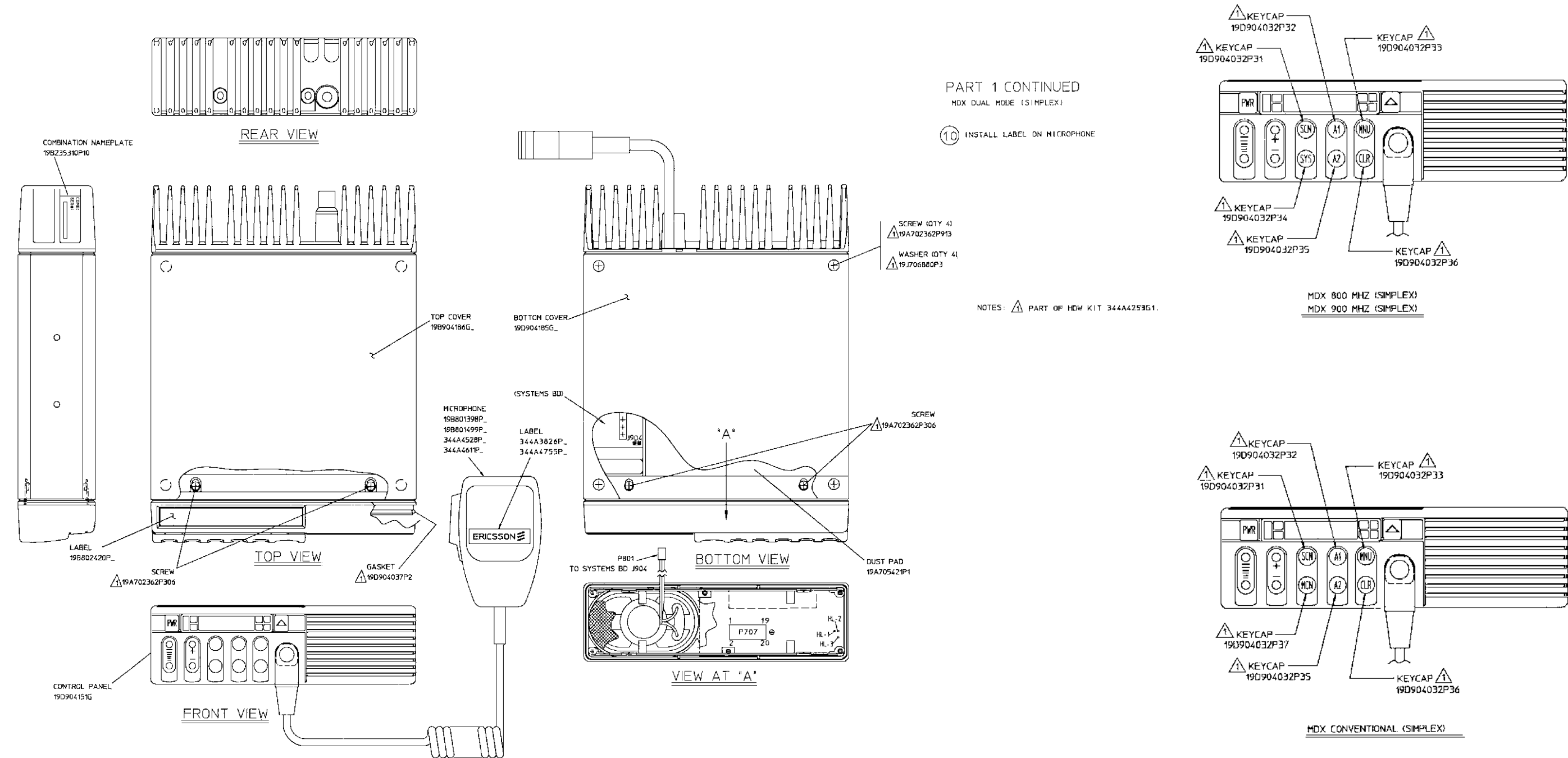

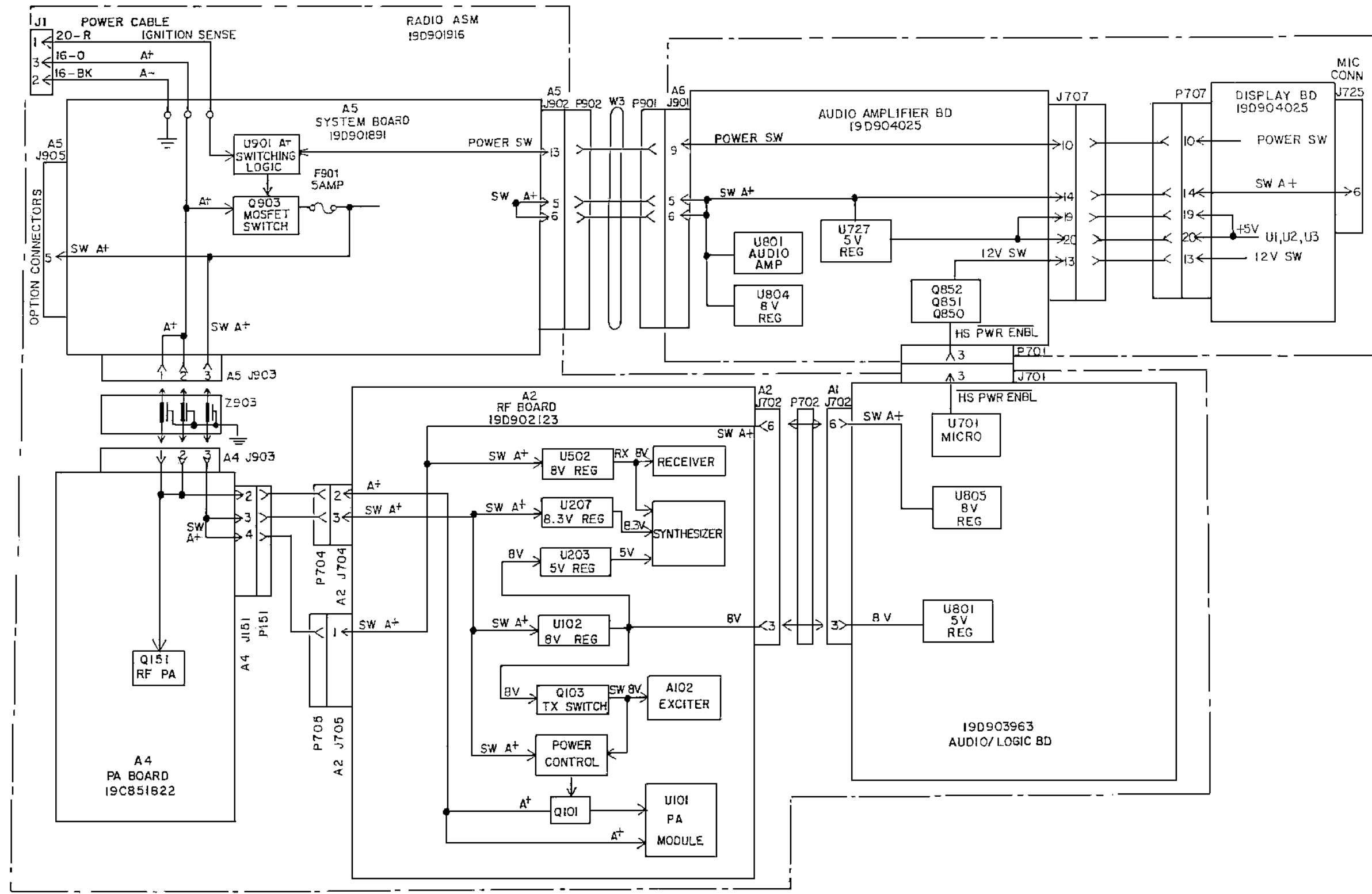
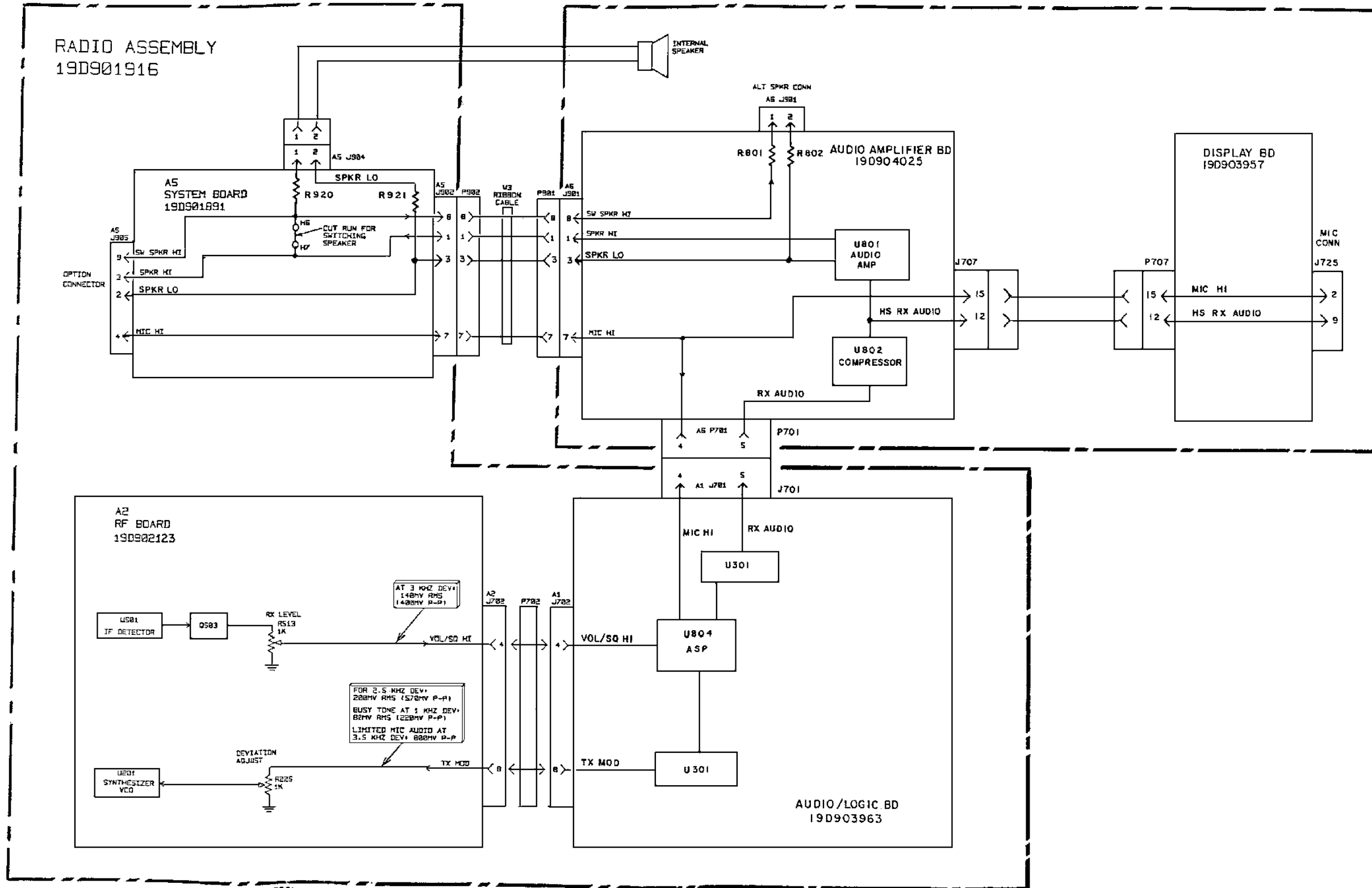

Figure 4 - Power Distribution Diagram



NOTES:
 1. RECEIVING A 1000 HZ 0d-FREQUENCY SIGNAL MODULATED BY 1000 HZ AT ±3KHZ DEVIATION.
 2. VOLUME ADJUSTED FOR 3 WATTS OUTPUT.

Figure 5 - Audio Signal Flow Diagram

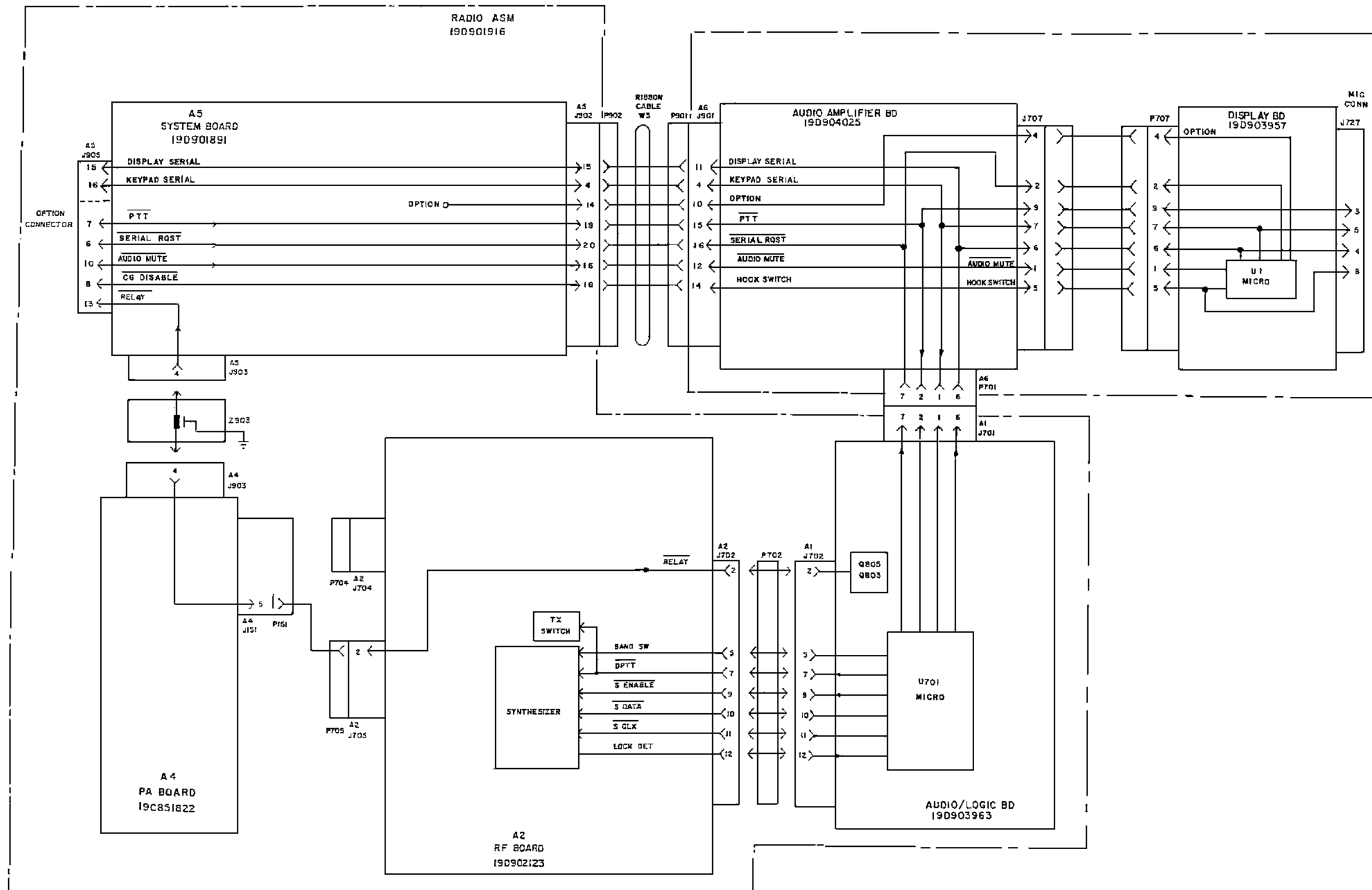

Figure 6 - Data Control Diagram