



SERVICE SECTION

ORION™

403-512 MHz

SYNTHESIZED TWO-WAY FM RADIO

TABLE OF CONTENTS

	<i>Page</i>
DESCRIPTION	2
INITIAL MEASUREMENTS	2
TRANSMITTER	2
RECEIVER	2
MAINTENANCE	3
PREVENTATIVE	3
DISASSEMBLY PROCEDURES	4
ALIGNMENT PROCEDURES	7
INTRODUCTION	7
TRACKING DATA	9
TEST FREQUENCIES	9
SETTING TRACKING DATA	10
TRANSMITTER ALIGNMENT	11
PA TRANSISTOR REPLACEMENT	11
RECEIVER ALIGNMENT	12
TEST EQUIPMENT REQUIRED	12
ADJUSTMENT PROCEDURES	12
SQUELCH ADJUSTMENT	13
TROUBLESHOOTING GUIDE	13
INTRODUCTION	13
MICROPHONICS	13
SERVICEABLE PARTS	14
DIAGNOSTIC PROCEDURES	16
ADDITIONAL TOOL REQUIRED	17
TRANSMITTER	17
RECEIVER	18
CONTROL UNIT	19
GENERAL	20
ERROR CODES	21

DESCRIPTION

This section contains the information required to service the ORION VHF two-way FM mobile radio. Included are disassembly procedures, alignment procedures and troubleshooting information (see Table of Contents).

This radio is adjusted by setting personality parameters stored in the radio computer memory. Therefore, all radio alignment procedures require the use of a **Personal Computer (PC)** (IBM PC, or equivalent) along with an Ericsson GE Programming Interface TQ3370, and ORION PC Programming cable TQ3377. Ericsson GE PC Programming Software Version 3.00 or later is also required.

This radio is designed to be serviced by replacement of modules and/or circuit boards. As such, there are very few serviceable component parts contained on any of the circuit boards within the radio. Normally, defective boards should be replaced and returned to an Authorized Ericsson GE Service Center. Any serviceable parts are listed in the troubleshooting guide for the individual circuit boards.

INITIAL MEASUREMENTS

After the radio has been installed as described in the Installation Manual, the following measurements should be made by a certified electronics technician and recorded for future reference:

TRANSMITTER

- RF power into 50 ohm resistive load
- Forward power into antenna
- Reflected power from antenna
- Carrier frequency
- Modulation deviation

RECEIVER

- 12 dB SINAD sensitivity

MAINTENANCE

PREVENTIVE MAINTENANCE

NOTE

To ensure high operating efficiency, and to prevent mechanical and electrical failures from interrupting system operations, routine checks should be made of all mechanical and electrical equipment at regular intervals. This preventive maintenance should include the checks as listed in Table 1, Maintenance Checks.

Table 1 - Maintenance Checks

MAINTENANCE CHECKS	INTERVAL
<p>CONNECTIONS - Ground connections and connections to the voltage source should be periodically checked for tightness. Loose or poor connections to the power source will cause excessive voltage drops and faulty operation. When ground connections are not made directly to the battery, the connection from the battery to vehicle chassis must be checked for low impedance. A high impedance may cause excessive voltage drops and alternator noise problems.</p>	<p>Every 6 months</p>
<p>ELECTRICAL SYSTEM - Check the voltage regulator and alternator or generator periodically to keep the electrical system within safe and economical operating limits. Over voltage is indicated when the battery loses water rapidly. Usage of 1 or 2 ounces of water per cell per week is acceptable for batteries in continuous operation. A weak battery will often cause excessive noise or faulty operation.</p>	<p>As Required</p>
<p>MECHANICAL INSPECTION - Since mobile units are subject to constant shock and vibration, check for loose plugs, nuts, screws, and parts to make sure that nothing is working loose. Be sure that all screws are properly torqued.</p>	<p>Every 6 months</p>
<p>ANTENNA INSPECTION - The antenna, antenna base, and all contacts should be kept clean and free from dirt or corrosion. If the antenna or its base should become coated or poorly grounded, loss of radiation and a weak signal will result.</p>	<p>Every 6 months</p>
<p>ALIGNMENT - The transmitter and receiver meter readings should be checked periodically, and the alignment "touched up" when necessary. Refer to the applicable Alignment Procedure and troubleshooting sheet for typical voltage readings.</p>	<p>As Required</p>
<p>FREQUENCY CHECK - Check transmitter frequency and deviation, as required by the FCC. Normally, these checks are made when the unit is first put into operation, after the first six months, and once a year thereafter.</p>	<p>As Required</p>

DISASSEMBLY PROCEDURE**To Remove Unit From Mounting Bracket**

1. Remove the microphone, power and accessory/remote control cables, as required.
2. Remove the lock screws at the side of the radio unit, using a #20 **TORX®** driver.
3. Pull the radio out of the mounting bracket.

To Gain Access To The Circuitry For Servicing**RF Power Amplifier Module:**

1. Remove the waterproof cover on bottom of the module, using a #20 **TORX®** driver. Note that the four mounting screws are captivated to the cover.
2. Remove the inner shield by pulling with the attached handle.

Transceiver (TXRX) Module:

1. Remove the waterproof top and bottom covers using #20 **TORX®** driver. Four cover mounting screws are located on the bottom of the module. These screws are captivated to the bottom cover.
2. To expose the Logic/Audio/455 kHz IF circuitry, remove the shield on top of the module by pulling with the attached handle.
3. To expose the Exciter/RX front end circuitry, remove the shield on the bottom of the module by pulling with the attached handle.

NOTE

The VCO/Synthesizer circuitry is exposed by removing screws from the shield casting, also located on the bottom of the module. However, this is not recommended, except in extreme situations. If the shield is removed, it should be replaced using exact screw torque and installation sequence given in maintenance manual LBI-38909.

Control Unit (Front Mounted):

1. Expose Logic/Audio/455 kHz IF circuitry according to instructions 1 and 2 above.
2. Disconnect Flex Circuit PC2 from connector J701, by carefully disengaging the locking tab from each side of the connector with a jeweler's screwdriver or tweezers. Use extreme care not to damage plating runs or surface mounted components on the printed wire board during this procedure.
3. Turn the radio upside down, and disengage the two mounting screws, using #10 **TORX®** driver. Be sure to engage the screws in the captivation threads on the transceiver chassis. Do this by pulling each screw upward with tweezers or needle nose pliers, while simultaneously turning the screw counterclockwise with the TORX (cr) driver. See maintenance manual LBI-38909 for more details.
4. Disengage the control unit from the transceiver chassis using a pivoting motion about the top edge of the transceiver chassis.
5. Disengage the four captivated screws on the rear cover, using #10 **TORX®** driver. Slide the rear cover off the front panel assembly, using care not to damage the black "**O-Ring**" moisture gasket attached to the rear cover. Note that flex circuit PC2 slides through a slot opening on the rear cover.

Control Head (Remote Mounting)

1. Disconnect the remote control and accessory cables, using a small flat blade screwdriver.
2. Remove the two side mounting screws from the mounting bracket. Carefully remove the control head assembly from the bracket.
3. Disengage the four captivated screws on the rear half , also known as the **Remote Interface Adapter (RIA)** of the control head. Slide the two halves apart, using care not to damage the black "**O-Ring**" moisture gasket attached to the RIA..
4. Disconnect flex circuit PC2 from connector J2, by carefully disengaging the locking tab from each side of the connector with a jeweler's screwdriver or tweezers. Use extreme care not to damage plating runs or surface mounted components on the printed wire board during this procedure.

To Reassemble The Radio After Service

Essentially follow the reverse of the above instructions. However, in order to preserve moisture seals, be sure to follow the **EXACT** torque and sequencing specifications for screw engagement during reassembly. These specifications are given in maintenance manual LBI-38909.

NOTE

For re-assembly of the Control Units (Front and Remote Mounting) Revision "A" or later, be sure the black "**O-Ring**" is lubricated properly with "HIVAC-G" silicone grease (See Figures 1A and 1B for instructions).

Steps:

1. Remove dust and dirt from the black O-Ring gasket.
2. Apply proper amount of the silicone grease to a cloth as shown in Figures 1A and 1B.
3. Put the silicon grease on the black O-Ring gasket, covering the surface of the gasket evenly (see Figure 1A and 1 B).

CAUTION

No Fibers of the cloth must remain on the gasket after the silicone is applied.

4. Wipe out protruded silicone grease form the Rear/RIA Cover.

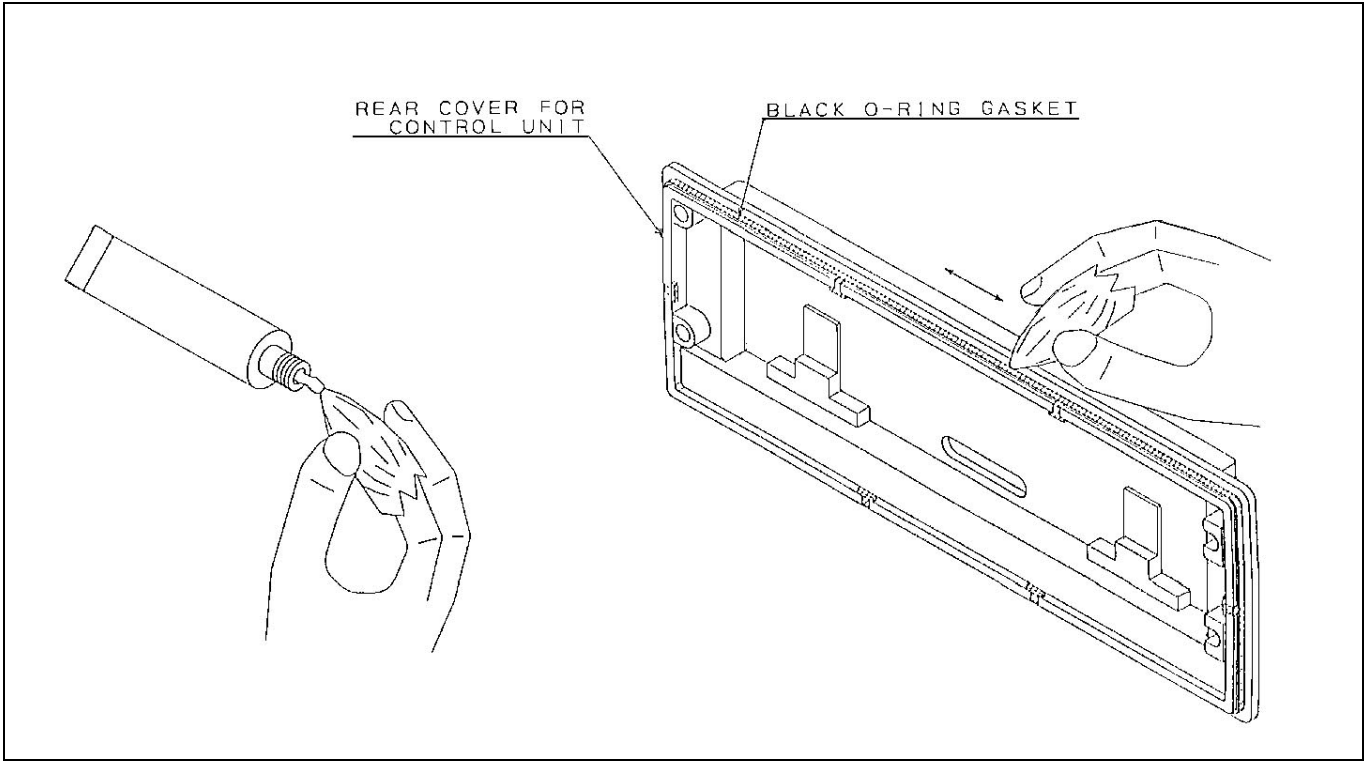

Figure 1A - Front Mount Control Unit "O-Ring" Lubrication

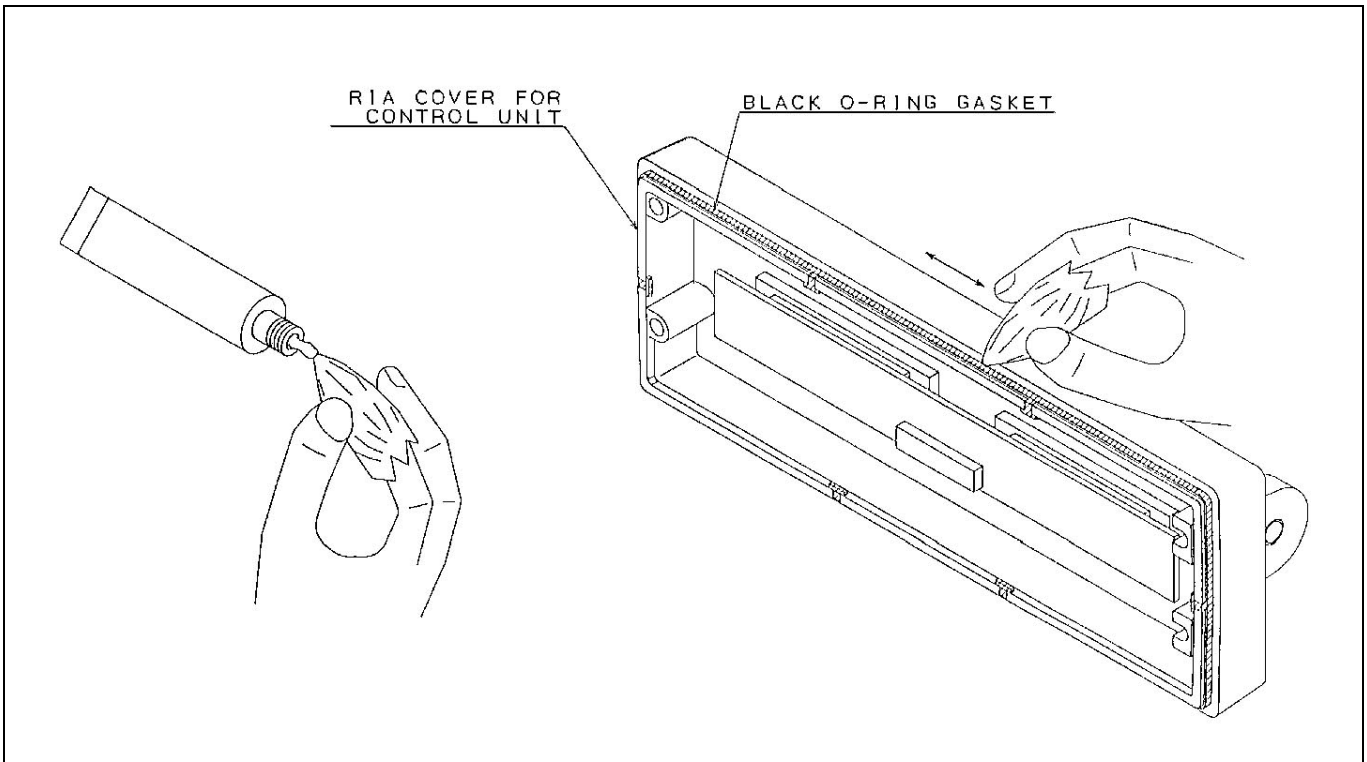

Figure 1B - Remote Mount Control Unit "O-Ring" Lubrication

ALIGNMENT PROCEDURES

INTRODUCTION

All operations of this radio are controlled by an embedded digital computer, which is programmed with a personality unique to the customer. In order to align and test the radio, it must be programmed with a specific test personality, which will allow conventional operation on certain test frequencies. Certain tests can be carried out by altering the personality. Furthermore, certain commands, known as Test Mode Commands, cause the radio to perform specific test functions. These will be noted as required in the following alignment and troubleshooting instructions.

In order to program an **ORION** personality, the radio and control unit must first be connected to a personal computer through PC Programming Cable and Hardware Programming Interface TQ3370, in one of the configurations shown in Figure 2 or 3. Accessories may be connected to the appropriate accessory cable 19B802554P1-P4 as needed.

The PC must be equipped with the Ericsson GE PC Programming Software, Version 4.0 or later. It is assumed in this manual that the Service Technician is familiar with the operation of the PC Programming Software programs "EDACS3" and "MRKMAINT". Consult the PC Programming Software manuals for further details regarding this software.

CAUTION

Before bench testing the radio, be sure of the output voltage characteristics of your bench power supply.

To protect the transmitter power output transistors from possible instant destruction, the following input voltages must not be exceeded.

Transmitter unkeyed	16.5 Volts
Transmitter keyed (50 ohms resistive load)	16.3 Volts
Transmitter keyed (No load or non-resistive load)	14.0 Volts

These voltages are specified at the normal vehicle battery terminals of the radio and take the voltage drop of standard cables into account. The voltage limits shown for a non-optimum load is for "worst case" conditions. For antenna mismatches likely to be encountered in practice, the actual limit will approach the 16.3 Volt figure.

Routine transmitter test should be performed at EIA Standard Test Voltages (13.6 Vdc for loads of 6 to 16 amperes; 13.4 Vdc for loads of 16 to 36 amperes). Input voltages must not exceed the limits shown, even for transient peaks of short duration.

Many commonly used bench power supplies cannot meet these requirements for load regulation and transient voltage suppression. Bench supplies which employ "**brute force**" regulation and filtering (such as Lapp Model 73) may be usable when operated in parallel with a 12 Volt automotive storage battery.

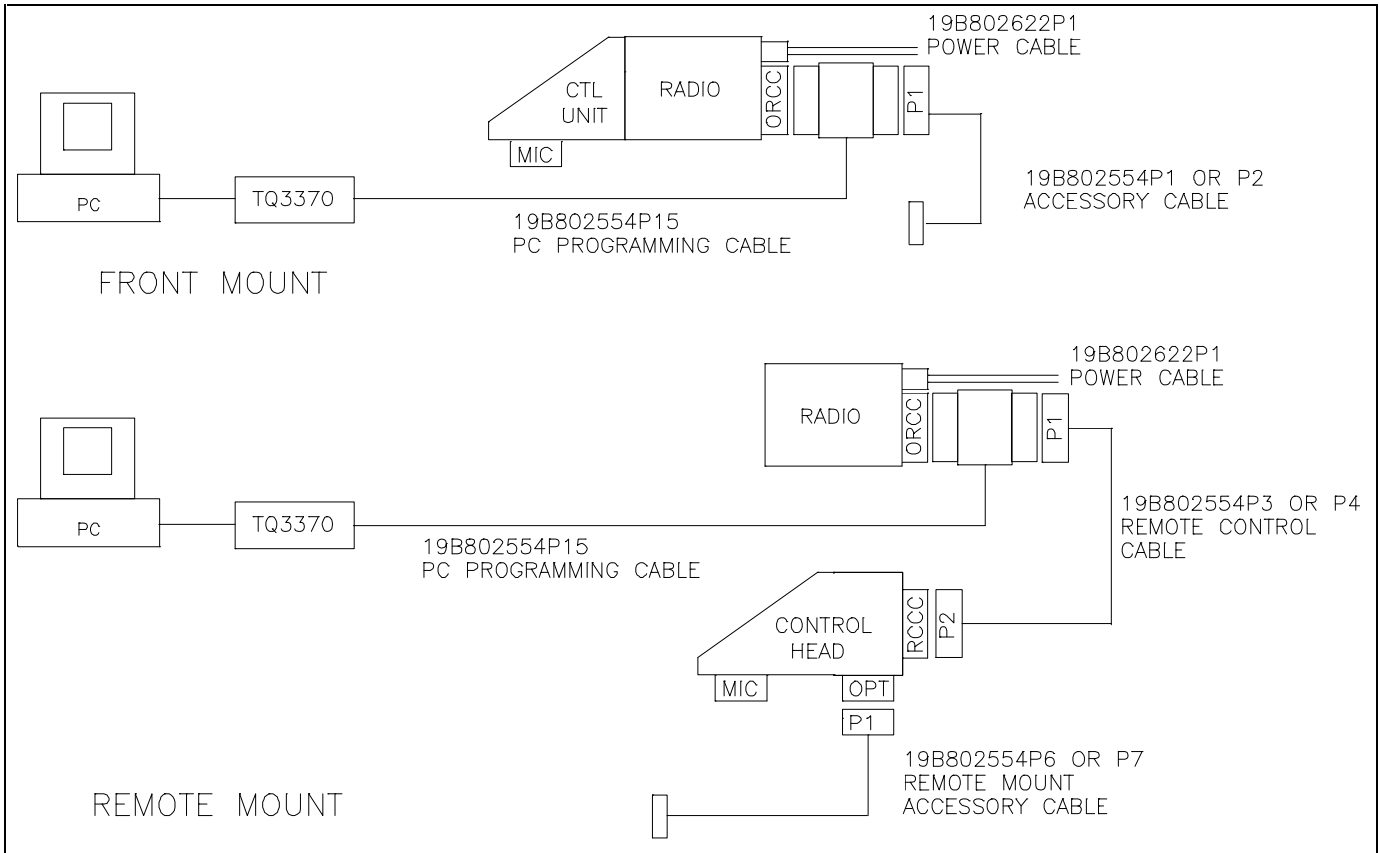

Figure 2 - ORION Programming Configurations (USA)

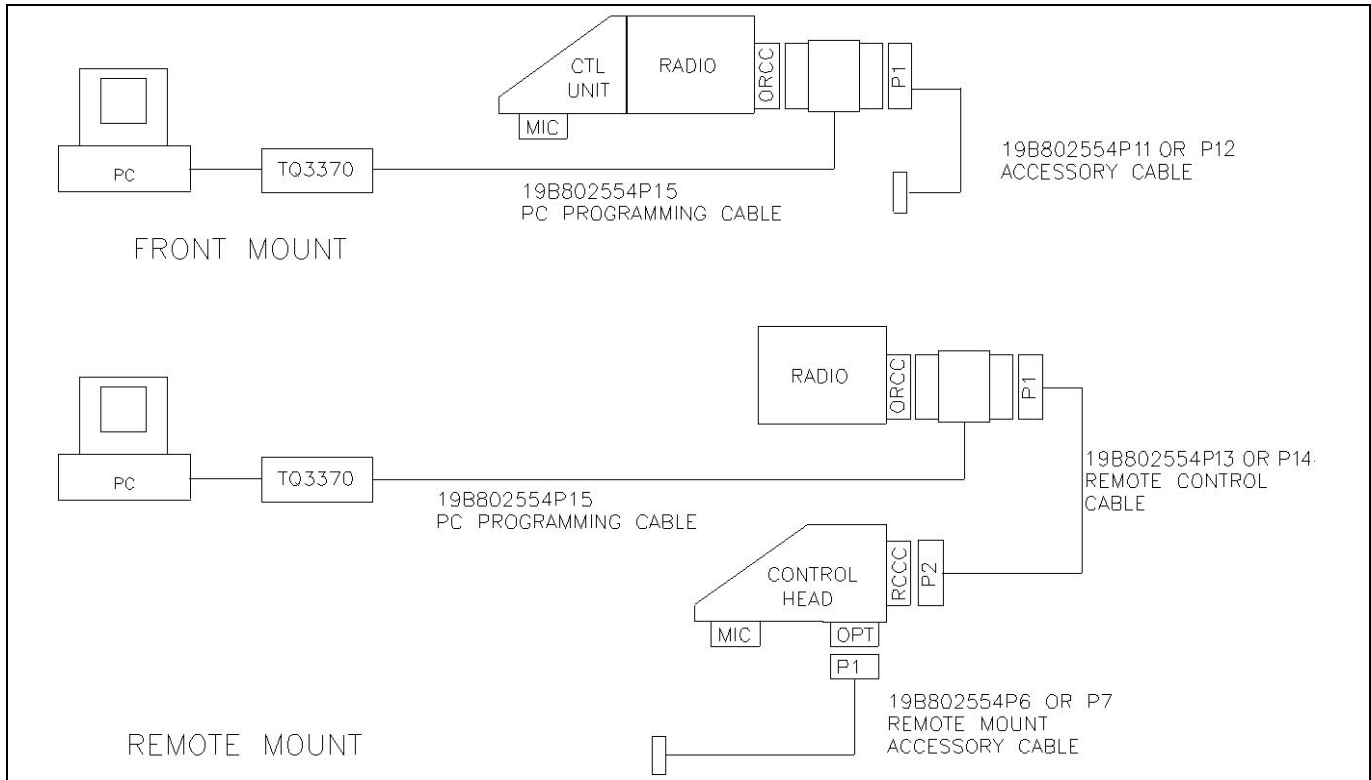

Figure 3 - ORION Programming Configurations (EUROPE)

TRACKING DATA

The radio personality contains certain information bytes known as **Tracking Data**, which allow the radio computer to calibrate transmitter power, modulation deviation and squelch threshold. Normally, no adjustments need be made to the radio to maintain specified limits for the above parameters, since the radio computer makes the necessary adjustments using the Tracking Data established at the factory. However, should the transmitter PA, synthesizer or logic circuit boards be replaced, it may be necessary to alter the Tracking Data to re-set these parameters properly. Furthermore, if the Tracking Data is lost, specialized

procedures are required to load new Tracking Data. Therefore, it is **VERY IMPORTANT** to establish a record of the Tracking Data of every radio as it is received from the factory. The frequencies at which Tracking Data is established are given in the "**Test Frequencies**" section.

TEST FREQUENCIES

The following frequencies are those for which Tracking Data is established and are used as Test Frequencies:

TABLE 2 - TRACKING DATA FREQUENCIES - LOW SPLIT

Parameter	RF Power	Modulation Deviation	Squelch Set
f1L (MHz)	403.0000	403.0000	403.0000
f1H (MHz)	N/A	411.0000	N/A
f2L (MHz)	411.9375	411.0125	411.9375
f2H (MHz)	N/A	420.0000	N/A
f3L (MHz)	421.0875	420.0125	421.0875
f3H (MHz)	N/A	429.5000	N/A
f4L (MHz)	430.4375	429.5125	430.4375
f4H (MHz)	440.0000	439.9875	440.0000

TABLE 3 - TRACKING DATA FREQUENCIES - MID SPLIT

Parameter	RF Power	Modulation Deviation	Squelch Set
f1L (MHz)	440.0000	440.0000	440.0000
f1H (MHz)	N/A	447.0000	N/A
f2L (MHz)	447.3125	447.0125	447.3125
f2H (MHz)	N/A	454.0000	N/A
f3L (MHz)	454.7500	454.0125	454.7500
f3H (MHz)	N/A	462.0000	N/A
f4L (MHz)	462.3125	462.0125	462.3125
f4H (MHz)	470.0000	470.0000	470.0000

TABLE 4 - TRACKING DATA FREQUENCIES - HIGH SPLIT

Parameter	RF Power	Modulation Deviation	Squelch Set
f1L (MHz)	470.0000	470.0000	470.0000
f1H (MHz)	N/A	478.0000	N/A
f2L (MHz)	480.9375	478.0125	480.9375
f2H (MHz)	N/A	488.0000	N/A
f3L (MHz)	491.0875	488.0125	491.0875
f3H (MHz)	N/A	499.0000	N/A
f4L (MHz)	501.4375	499.0125	501.4375
f4H (MHz)	512.0000	512.0000	512.0000

SETTING TRACKING DATA

Normally, tracking data is set at the factory and need not be reloaded. However, the following repair situations require reloading some or all of the tracking data:

<u>SITUATION</u>	<u>NEW TRACKING DATA REQUIRED</u>
Replace PA module	RF Power, Squelch (Reload if necessary)
Replace TXRX module	RF Power, Modulation Deviation, Squelch, Feature Encryption, Data Offset
Replace Control Unit	None
Replace synthesizer Board	Modulation Deviation, Data Offset
Replace Logic Board	RF Power, Squelch, Modulation Deviation, Feature Encryption, Data Offset

To reload Tracking Data, connect the radio in the appropriate configuration as shown in Figure 1 or 2, and perform the following steps:

1. When using the Ericsson GE PC Programming Software, make sure the radio is programmed in the following sequence:
 - a. Customer Operational Software (If necessary)
 - b. Tracking Data (1st Iteration - Tracking Data originally shipped with the radio is a good starting point)
 - c. Feature Encryption File (If necessary). Note that in order to load an Encryption File into a new Logic board, Ericsson GE Service Parts Department must first be contacted at 1-800-368-3277 for the authorization code. Otherwise, the file will not load.
 - d. Personality, which contains a **CONVENTIONAL SYSTEM** using the frequencies given in Table 2 or Table 3.
2. Connect the radio unit in the normal operating configuration. Activate the radio unit and using a Service Monitor HP8920A or equivalent. Measure transmitter power, modulation deviation and squelch threshold for each of the applicable frequencies given in Table 2 or Table 3. Measurements should be within the following limits:

<u>PARAMETER</u>	<u>LIMIT</u>
TX Modulation Deviation	4.4 ± 0.1 kHz
TX High Power	
100/80 Watt Model	100/80 +4, -0 Watts
40/35 Watt Model	40/35 +2, -0 Watts
20 Watt Model	20 +0, -1 Watt
TX Mid Power	12 +0.5, -0.5 Watts
(20 Watt Model)	
100.80 Watt Model	50/40 +2, -0 Watts
50/35 Watt Model	25/17 +1, -0 Watts
20 Watt Model	6 +0.5, -0.5 Watts
RX Squelch Threshold	8 +1, -0 dB SINAD

3. If measurements are within limits, the job is complete. If not, reconnect in the programming configuration according to Figures 1 or 2 and execute the programming maintenance software "MRKMAINT". Display the Tracking Data screen. For those frequencies where measurements are not within limits, enter new Tracking Data, following instructions on the screen. Program into radiopersonality and exit.
4. Repeat Steps 2 and 3 until measurements at every frequency given in Table 2 or 3 are within the limits specified above.

RECEIVER ALIGNMENT

Alignment of the Front End and Local Injection circuits are not required because band-pass filters are employed in the ORION wide-band synthesized radio receiver.

TEST EQUIPMENT REQUIRED

- Distortion Analyzer
- AC Voltmeter
- RF Signal Generator
- Frequency Counter (403-512 MHz)
- 4-Ohm, 25-Watt Resistor
- Audio Isolation Transformer (1:1)
19A116736P1 or equivalent

NOTE

Before aligning the receiver or making any adjustments to the radio, be sure that the output of the 9-Volt Regulator is 9.0 ± 0.2 Vdc.

ADJUSTMENT PROCEDURES

Receiver Frequency Adjustment

No receiver frequency adjustment is required.

2nd Receiver Oscillator

Using a frequency counter monitor TP5 Terminal, set L521 for a frequency of $82.655 \text{ MHz} \pm 200 \text{ Hz}$.

IF/FM Detector Alignment

1. Apply a 1000 micro volt, on-frequency test signal modulated by 1,000 Hz with standard deviation to antenna jack J1.
2. Connect a 4-ohm, 25-watt resistor in place of the speaker. Connect the isolation transformer input across the resistor. Connect the isolation transformer output to the Distortion Analyzer (see Figure 4).
3. Adjust the VOLUME control for 15 watts output (7.75 VRMS) using the Distortion Analyzer as a voltmeter.
4. Set the output signal level of the RF signal generator so as to obtain 12 dB SINAD at audio output.
5. Adjust coils L502, L504, L505, and L507 to obtain minimum 12 dB SINAD.
6. Set the output signal level of the RF signal generator to 1000 microvolts.
7. Adjust L523 for maximum audio output.
8. Adjust RV501 for XTONEDDEC output at ORCC to 500 mVRMS.

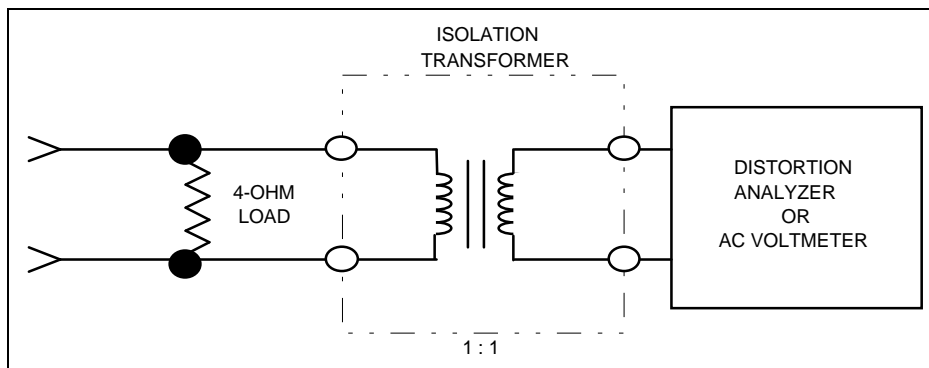

Figure 4 - Audio Isolation Transformer

NOTE

Isolation transformer needed only if instrument cannot be isolated from ground at input terminals.

SQUELCH ADJUSTMENT

Squelch threshold has been set at the factory to 8 dB SINAD. Adjustment of the threshold requires changing the tracking Data. To change the squelch tracking data, follow the iterative procedure set forth in the "**TRACKING DATA**" section, except let the desired squelch threshold level replace the 8 +1, -0 dB SINAD level set at the factory. **BE SURE TO CHANGE THE TRACKING DATA FOR ALL FREQUENCIES GIVEN IN TABLE 2 OR 3.** Otherwise the level will not be consistent across the frequency band.

TROUBLESHOOTING GUIDE

INTRODUCTION

This radio is designed to be serviced by replacement of modules an/or circuit boards. As such, there are very few serviceable component parts contained on any of the circuit boards within the radio. Normally, defective boards should be replaced and returned to an Authorized Ericsson GE Service Center. A list of serviceable parts is given in the next section.

MICROPHONICS

Synthesized radios tend to be sensitive to shock and vibration, creating microphonics. The construction of the **ORION** radio with its die-cast aluminum frame, cast shield, and multiple board-mounting screws, provides a high degree of immunity. When removing printed circuit boards or shields, note the location of all mounting hardware.

When servicing the radio be sure that no solder build-up has occurred on the chassis or shield.

To assure a high degree of resistance to microphonics be sure to replace exactly, all hardware removed. Be sure that all mounting screws are properly torqued and shields are in place. Refer to the Mechanical Layout Diagram found in LBI-38909.

NOTE

Loose or rubbing parts, especially in the VCO area, are particularly sensitive and can cause microphonics. Again, be certain all hardware is properly installed and torqued.

SERVICEABLE PARTS**Control Unit - Switch Circuit CDF-368B/M**

No serviceable parts.

Control Unit - Panel Control CMC-638

No serviceable parts.

Remote Control Unit - RIA NQZ-4882

J2	Connector, 18 pin	B19/5JBAX00020
----	-------------------	----------------

Radio Unit - System Control CMC-682

F601	Fuse, 5 amp.	B19/5ZFAP00008
IC604	AF Power Amplifier	B19/5DAAA00350
J701	Connector, 18 pin	B19/5JDAG00315

Radio Unit - IF CMF-135

No Serviceable parts.

Radio Unit - Synthesizer/Receiver/Exciter CMN-354

No Serviceable parts.

Radio Unit - Power Amplifier 100/80 Watts CAH-545H

C9	Capacitor, 56 pF (403-440 MHz)	B19/5CAAA03095
C9	Capacitor, 47 pF (440-470 MHz)	B19/5CAAA03080
C9	Capacitor, 47 pF (470-512 MHz)	B19/5CAAA03080
C10	Capacitor, 56 pF (403-440 MHz)	B19/5CAAA03095
C10	Capacitor, 43 pF (440-470 MHz)	B19/5CAAA03828
C10	Capacitor, 36 pF (470-512 MHz)	B19/5CAAA03131
C11	Capacitor, 56 pF (403-440 MHz)	B19/5CAAH00033
C11	Capacitor, 47 pF (440-470 MHz)	B19/5CAAH00035
C11	Capacitor, 33 pF (470-512 MHz)	B19/5CAAH00039
C12	Capacitor, 39 pF (403-440 MHz)	B19/5CAAH00037
C12	Capacitor, 33 pF (440-470 MHz)	B19/5CAAH00039
C12	Capacitor, 33 pF (470-512 MHz)	B19/5CAAH00039
C20	Capacitor, 56 pF (403-440 MHz)	B19/5CMAB01431
C20	Capacitor, 47 pF (440-470 MHz)	B19/5CMAB01252
C20	Capacitor, 36 pF (470-512 MHz)	B19/5CMAB01442
C21	Capacitor, 47 pF (403-440 MHz)	B19/5CMAB01252
C21	Capacitor, 39 pF (440-470 MHz)	B19/5CMAB01430
C21	Capacitor, 36 pF (470-512 MHz)	B19/5CMAB01442
C22	Capacitor, 43 pF (403-440 MHz)	B19/5CAAH00036
C22	Capacitor, 36 pF (440-470 MHz)	B19/5CAAH00038

Continued

Continued

C22	Capacitor, 36 pF (470-512 MHz)	B19/5CAAH00038
C23	Capacitor, 43 pF (403-440 MHz)	B19/5CAAH00036
C23	Capacitor, 47 pF (440-470 MHz)	B19/5CAAH00035
C23	Capacitor, 33 pF (470-512 MHz)	B19/5CAAH00039
C29	Capacitor, 47 pF (403-440 MHz)	B19/5CMAB01252
C29	Capacitor, 39 pF (440-470 MHz)	B19/5CMAB01430
C29	Capacitor, 36 pF (470-512 MHz)	B19/5CMAB01424
C30	Capacitor, 56 pF (403-440 MHz)	B19/5CMAB01431
C30	Capacitor, 47 pF (440-470 MHz)	B19/5CMAB01252
C30	Capacitor, 36 pF (470-512 MHz)	B19/5CMAB01442
C31	Capacitor, 43 pF (403-440 MHz)	B19/5CAAH00036
C31	Capacitor, 47 pF (440-470 MHz)	B19/5CAAH00035
C31	Capacitor, 33 pF (470-512 MHz)	B19/5CAAH00039
C32	Capacitor, 43 pF (403-440 MHz)	B19/5CAAH00036
C32	Capacitor, 36 pF (440-470 MHz)	B19/5CAAH00038
C32	Capacitor, 36 pF (470-512 MHz)	B19/5CAAH00036
HC1	Power Module (403-440 MHz)	B19/5DDAB00495
HC1	Power Module (440-470 MHz)	B19/5DDAB00496
HC1	Power Module (470-512 MHz)	B19/5DDAB00497
TR1	Transistor, NPN	B19/5TCAD00088t
TR2	Transistor, NPN	B19/5TCAD00144
TR3	Transistor, NPN	B19/5TCAC00144

Radio Unit - Power Amplifier 40/35 Watts CAH-545L

C9	Capacitor, 56 pF (403-440 MHz)	B19/5CAAA03095
C9	Capacitor, 47 pF (440-470 MHz)	B19/5CAAA03080
C9	Capacitor, 47 pF (470-512 MHz)	B19/5CAAA03080
C10	Capacitor, 56 pF (403-440 MHz)	B19/5CAAA03095
C10	Capacitor, 47 pF (440-470 MHz)	B19/5CAAA03080
C10	Capacitor, 36 pF (470-512 MHz)	B19/5CAAA03131
C11	Capacitor, 36 pF (403-440 MHz)	B19/5CAAH00038
C11	Capacitor, 33 pF (440-470 MHz)	B19/5CAAH00039
C11	Capacitor, 33 pF (470-512 MHz)	B19/5CAAH00039
C12	Capacitor, 51 pF (403-440 MHz)	B19/5CAAH00034
C12	Capacitor, 47 pF (440-470 MHz)	B19/5CAAH00035
C12	Capacitor, 47 pF (470-512 MHz)	B19/5CAAH00035
HC1	Power Module (403-440 MHz)	B19/5DDAB00495
HC1	Power Module (440-470 MHz)	B19/5DDAB00496
HC1	Power Module (470-512 MHz)	B19/5DDAB00497
TR1	Transistor, NPN	B19/5TCAD00088

Radio Unit - Power Amplifier 20 Watts CAH-545E

HC1	Power Module (403-440 MHz)	B19/5DDAB00493
HC1	Power Module (440-470 MHz)	B19/5DDAB00494

DIAGNOSTIC PROCEDURES

This product can be easily measured for maintenance using a Communications Service Monitor, of which several models are available. A typical test configuration for the ORION product is shown in Figure 5.

NOTE

It is also possible to combine this test configuration with the PC programming configuration shown in Figures 2 and 3. This usually results in increased efficiency, since the service technician can alternate between programming and hardware testing, as the need arises.

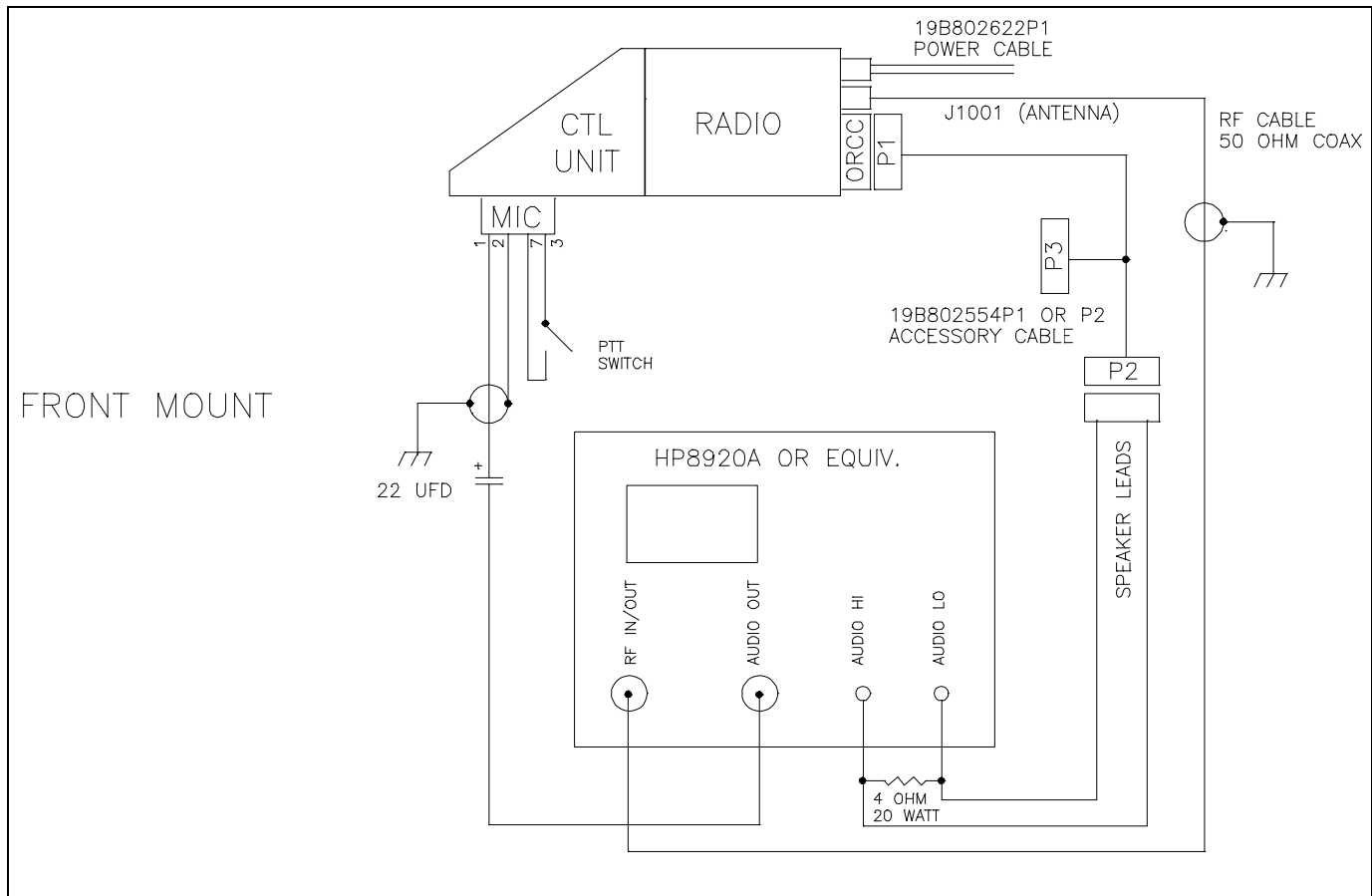

Figure 5 - Typical ORION Test Configuration

ADDITIONAL TOOLS REQUIRED:

- RF Power Attenuator (30 dB, 150 watt, for transmitters with RF power beyond capability of the Service Monitor)
- Digital Voltmeter
- Oscilloscope (Optional)

TRANSMITTER

SYMPTOM	DIAGNOSTIC PROCEDURE
No RF power output	a) Program a conventional system with frequencies given in Table 2 or 3. Use the "EDACS3" PC Programming utility. b) Check RF Power Tracking Data, using the "MRKMAINT" PC programming utility. Data should be the same as that shipped with the radio. If fail, re-enter Tracking data using procedure given in the " Tracking Data " Section of this manual. c) Check TP1 on PA board for A+. If not there, check power cable fuse. d) Key the radio and measure the DC voltage at TP4 (9 Vdc typical, when keyed). If not there, trace TXENABLE signal back to Logic board. e) Unscrew PA module from rest of the radio unit. Remove P1 from J151 and connect an RF wattmeter to J151. Power should be 400-700 mW. If not, replace Synthesizer board and reload the Modulation Tracking Data. If the correct power level is there, replace PA board.
Frequency too low/high	Adjust the reference oscillator XU201 on the Synthesizer board. If the frequency still not correct, replace the Synthesizer board.
Low or no modulation	a) Program a conventional system with frequencies given in Tables 2 or 3. Use the "EDACS3" PC programming utility. b) Check the Modulation Tracking Data, using the "MRKMAINT" PC programming utility. The data should be the same as that shipped with the radio. If not, re-enter the Tracking Data using the procedure given in the " Tracking Data " section of this manual. c) Apply a 1000 mVRMS, 1 kHz audio signal to the microphone connector, Pin 1 (Pin 2 is ground reference). Key the radio (make sure the antenna connector is connected to the proper 50 ohm load). Check for an audio signal at TP202 on the Synthesizer board. If not there, replace the Synthesizer board and reload the Modulation Tracking Data.

RECEIVER

SYMPTOM	DIAGNOSTIC PROCEDURE
Low RF sensitivity	<ul style="list-style-type: none"> a) Program a Conventional System with frequencies given in Tables 2 or 3. Use "EDACS3" PC programming utility. b) Unscrew the PA module from the TXRX module. Disconnect coaxial cable P2 from J401 on the Synthesizer board. <u>Do not</u> disconnect any other cable. c) Set the frequency of the RF signal generator to the middle of the split. Apply a standard RF signal to J401 and measure 12 dB SINAD sensitivity. Sensitivity should be better than 0.29 μV. d) If correct, replace the PA board. e) If not, realign the receiver, as instructed in the "ALIGNMENT" section and recheck sensitivity at J401. f) If correct now, reassemble with the PA module and recheck sensitivity at the antenna connector. If correct, the job is complete. g) If not correct, substitute a known good Synthesizer board and recheck sensitivity. h) If still not correct, replace the Logic board. Be sure to perform complete reprogramming on the new logic board. If correct, replace the Synthesizer board and reload Modulation Tracking Data.
High audio distortion	<ul style="list-style-type: none"> a) Program a Conventional System with frequencies given in Tables 2 or 3. Use the "EDACS3" PC programming utility. b) Apply a standard 1000 μV RF signal (with 1 kHz audio modulation at 3 kHz deviation) at one of the programmed RF frequencies in the center of the split to J1001. Set the volume control to produce 15 watts at the 4 ohm speaker load. c) Measure audio distortion at "VOL HI" output (J1003, Pin 13 referenced to Pin 12). If correct (3% THD), replace IC604 Audio Power Amplifier on the Logic board. d) If not, realign the receiver according to the alignment procedure. Recheck distortion at the speaker load or "VOL HI". e) If not correct, replace the Logic board. If correct, job is complete.

CONTROL UNIT

SYMPTOM	DIAGNOSTIC PROCEDURE
Radio dead at power-on (display dark and no lighted indicators)	<p>a) Check battery connections and the Red Lead A+ fuse on the Power Cable.</p> <p>b) Turn unit "OFF", then simultaneously press and hold "EMERGENCY" and "OPTION" buttons, while turning the unit "ON". All indicator lights and all display dots should light. Release the buttons and the display should show the following message:</p> <p style="text-align: center;">(C) - 1993 EGE</p> <p>This indicates that the Control Unit is functioning correctly. If correct, check programming and feature encryption, using the "EDACS3" PC programming utility.</p> <p>c) If not correct, measure A+ voltage at the microphone connector, Pin 6 (reference ground at Pin 7). If not present, check fuse F601 on the Logic board for A+ on each side of part. Replace if open circuited.</p> <p>d) If the fuse is OK, check the connection of Flex Circuit PC2 with J701 on the Logic board. If still not present, reconnect, making sure side tabs are locked. Recheck microphone connector Pin 6 for A+.</p> <p>e) If A+ is present, Check programming and feature encryption, using "EDACS3" PC programming utility. If symptom persists, substitute a known good Logic board and reprogram.</p> <p>f) If no A+ is at the microphone, Pin 7, check for A+ on the Logic board, J704, Pin 3. If not there, check the J704/J1004 connection. If still not there, replace the PA module. If there, replace the Logic board.</p>
Display lights, then goes dead	<p>a) Turn unit "OFF", then simultaneously press and hold the "EMERGENCY" and "OPTION" buttons, while turning the unit "ON". All indicator lights and all display dots should light. Release the buttons and the display should show the following message:</p> <p style="text-align: center;">(C) - 1993 EGE</p> <p>This indicates that the Control Unit is functioning correctly. If OK, check programming and feature encryption, using "EDACS3" PC programming utility.</p> <p>b) If OK, check connection of Flex Circuit PC2 with J701 on the Logic board. If not OK, reconnect , making sure side tabs are locked.</p>

GENERAL

SYMPTOM	DIAGNOSTIC PROCEDURE
Any Hardware malfunction	<p>Printed Wire Board substitution is a valid technique for service and repair of the ORION product, since there are only a few circuit boards in the product:</p> <ol style="list-style-type: none"> 1) RF Power Amplifier 2) Logic/IF/Audio 3) Synthesizer/Exciter/RX Front End 4) Control Unit Panel Control 5) Control Unit Switching 6) Control Unit RIA (Remote only) 7) DSP (AEGIS only) <p>The service shop should be equipped with a set of the above circuit boards which can be used for substitution. Defective circuit boards can be isolated simply by substituting one at a time. It is recommended that the Logic board used for substitution be pre-programmed with a conventional system and frequency set given in Tables 2 or 3.</p>

ERROR CODES

This section list all of the ORION radio errors and warnings. Each error code in the list includes an explanation of what went wrong and what action to take to correct the problem. These error codes are divided into three different categories:

1. **Fatal Operational Error Codes** - These are errors that are displayed during the radio normal operation or on the radio power-up (Fatal System Errors). These errors will cause the radio to reset.
2. **Non-Fatal Operational Error Codes** - These are errors that are displayed during the radio normal operation or on the radio power-up. The radio will NOT reset.
3. **Radio Programming Errors** - These are errors that are displayed on the radio or the programming PC display during radio programming.

All System Groups ORION

System Errors:

Fatal system errors will cause the radio to display an error message/code and then reset the radio to the starting operation. The reset condition will remain until the fatal error(s) is (are) corrected.

Non-Fatal errors are displayed for a short period (about 2 seconds) then normal radio operation will resume.

The errors are displayed on the radio as shown in Figure 6.

ERROR CODES

Figure 6 - Error Message/Code Display

FATAL ERRORS	
<u>ERROR MESSAGE</u>	<u>DESCRIPTION</u>
HARDWARE	ROM errors
SOFTWARE	General software failure
TRACKING	Tracking data fatal error
NO LOCK	Synthesizer not locking
FREQDATA	Frequency data fatal error
PERSDATA	Personality errors

NON-FATAL ERRORS	
<u>ERROR MESSAGE</u>	<u>DESCRIPTION</u>
UNKNOWN	
FEAT ERR	Feature encryption error
DSP ERR	DSP error

ROM Fatal Systems Errors

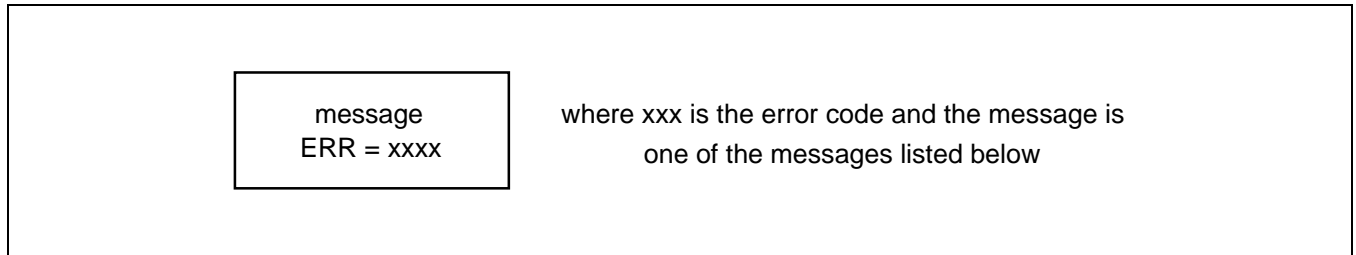
ROM fatal errors may be corrected by cycling the radio power (turn it off then on). When the power cycle does not correct the problem the radio must be serviced.

ERROR NAME	MESSAGE	CODE	DESCRIPTION
FATAL_SYS_TRAP	HARDWARE	0	Fatal system error trap number.
FATAL_NMI_ERROR	HARDWARE	1	NMI occurred outside of sleep.
FATAL_RAM_ERROR	HARDWARE	2	8K RAM test error.
FATAL_ROM_CHKSUM	HARDWARE	3	32K ROM checksum test error.
FATAL_FLSH_CHKSUM	HARDWARE	4	Flash checksum test error.
FATAL_ASIC_LOAD	HARDWARE	10	ASIC driver failed initialization.
FATAL_ICP_LOAD	HARDWARE	11	ICP driver failed initialization.
FATAL_ASP_LOAD	HARDWARE	12	ASP driver failed initialization.
FATAL_EE_LOAD	HARDWARE	13	EEPROM driver failed initialization.
FATAL_ICP_PORTNIT	HARDWARE	14	ICP digital I/O initialization failed.
FATAL_INTOUT_LOAD	HARDWARE	15	Standard input/output driver failed initialization.
FATAL_INTIN_LOAD	HARDWARE	16	Standard input driver failed initialization.
FATAL_RADIO_LOAD	HARDWARE	17	RADIO driver failed initialization.
FATAL_MODEM_LOAD	HARDWARE	18	MODEM driver failed initialization.
FATAL_EXTIO_LOAD	HARDWARE	19	External I/O driver failed initialization.
FATAL_SCI_LOAD	HARDWARE	20	Serial communication interface driver failed initialization.
FATAL_ICP_CHKSUM	HARDWARE	21	ICP prom checksum.
FATAL_ADI_NOACK	HARDWARE	30	ADI did not respond to command.
FATAL_LCD_NOACK	HARDWARE	40	LCD did not acknowledge message.
FATAL_LCD_HARD_FAIL	HARDWARE	41	LCD hardware is invalid.
FATAL_SCI_NOHEAP	HARDWARE	50	Serial communication interface out of heap (RAM memory) space.
FATAL_ICP_NOACK	HARDWARE	60	ICP did not acknowledge message.
FATAL_EXTIO_ICPFAIL	HARDWARE	70	ICP failed in a fork.
FATAL_RADIO_ASPWRT	HARDWARE	80	Radio driver could not write to ASP.
FATAL_ROM_NOHEAP	HARDWARE	90	Software memory error - ROM task.
FATAL_BL_NOHEAP	HARDWARE	91	Software memory error - Boot loader.
FATAL_BL_SCI_ATTACH	HARDWARE	92	Boot loader could not attach to SCI.

Operational Software Non-Fatal System Errors

ERROR NAME	MESSAGE	CODE	DESCRIPTION
PIFEAT_SNR_ERROR	FEAT ERR	550	Feature encryption - Can not read radio ROM serial number.
PIFEAT_READ_ERROR	FEAT ERR	551	Personality feature encryption read failure or data not available.
PIFEAT_CRC_ERROR	FEAT ERR	552	Decryption failure. Personality feature encryption CRC failure.
AEGIS_ADIDOWN_NOTFOUND	DSP ERR	851	DSP file not found.
AEGIS_ADIDOWN_CRCFAIL	DSP ERR	852	DSP file not found.
AEGIS_ADIDOWN_ENCERR	DSP ERR	853	Radio feature encryption does not match DSP file.
AEGIS_ADIDOWN_PMFAIL	DSP ERR	854	DSP file is corrupted or hardware failure. RE-program radio or power cycle the radio.
AEGIS_ADIDOWN_DMFAIL	DSP ERR	855	DSP file is corrupted or hardware failure. Re-program radio or power cycle radio.
AEGIS_ADIDOWN_BIOSERR	DSP ERR	856	Hardware failure.

Operational Software Fatal System Errors

ERROR NAME	MESSAGE	CODE	DESCRIPTION
RADC_PITD_ERROR	TRACKING	200	Personality tracking data error. Re-program the tracking data.
RADC_PIHW_ERROR	PERSDATA	201	Personality hardware data error. Re-program the personality.
RADC_FREQ_ERROR	FREQDATA	202	Personality frequency data error. Re-program the personality.
RADC_PITD_MALLOC_ERROR	SOFTWARE	203	Personality tracking data malloc error. Re-program the tracking data.
RADC_PITD_CKSUM_ERROR	SOFTWARE	204	Personality tracking data checksum error. Re-program the tracking data.
DACS_NO_LOCK	NO LOCK	300	Synthesizer did not lock or became unlocked. Check the frequencies in the PC programmer and re-program the radio personality.
DACS_MODEM_FATAL_ERROR	SOFTWARE	301	Unable to correctly configure the modem for EDACS operation. Re-program the personality.
DACS_RADC_FAILURE	SOFTWARE	302	Power cycle the radio.
DACS_MODEM_RXOVR	SOFTWARE	304	Hardware Modem overflow. Power cycle the radio.
DACS_MODEM_RXAVR	SOFTWARE	305	Power cycle the radio.
CONV_RADC_ERROR	SOFTWARE	400	Error calling RADC function. Power cycle the radio.
CONV_NOLOCK_ERROR	NO LOCK	401	Synthesizer became unlocked. check the frequencies in the PC programmer and re-program the radio personality.
CONV_PUT_UIMSG_ERROR	SOFTWARE	402	UI message buffer not enabled. Power cycle the radio.
CONV_MODEM_RXOVR	SOFTWARE	403	Conventional DIGV modem overflow.
CONV_MODEM_RXAVR	SOFTWARE	404	Conventional DIGV modem underflow.
CONV_MODEM_FATAL_ERROR	SOFTWARE	405	Unable to correctly configure the modem for conventional DIGV operation.
CONV_PERS_ERROR	PERSDATA	407	Conventional personality error.
PI_NOPERS_ERROR	PERSDATA	500	Personality data is not present. Program the personality.
PI_CRC_ERROR	PERSDATA	501	Flash personality CRC did not match EEPROM. Re-program the personality.
PI_DESC_CRC_ERROR	PERSDATA	502	Crucial personality data has incorrect CRC. Re-program the personality.
PI_MALLOC_ERROR	SOFTWARE	503	Could not allocate memory to store crucial personality data.
UI_FATAL_DEVICE_ERROR	PERSDATA	600	Input/Output device error.
UI_FATAL_SWTO_MALLOC_ERROR	SOFTWARE	601	Software memory error.
UI_FATAL_SWTO_MAX_ERROR	SOFTWARE	602	Software error, power cycle the radio.
UI_FATAL_WINDOW_MAX_ERROR	SOFTWARE	603	Too many open windows.
UI_FATAL_WINDOW_MALLOC_ERROR	SOFTWARE	604	Software memory error.
UI_FATAL_MESSAGE_INV_P_ARM	SOFTWARE	605	Invalid parameter to UI_PUT_MESSAGE(). software error, report how error was encountered.
UI_FATAL_RI_MSGBUF_FULL	SOFTWARE	606	UI Task message buffer full error. Software error, report how error was encountered.
UI_FATAL_RISYS_MSGBUF_FULL	SOFTWARE	607	Radio Interface System (EDACS/CONV) task message buffer full.
UI_FATAL_CI_MSGBUF_FULL	SOFTWARE	608	CI Task message buffer full.
UI_FATAL_DEVICE_NOTSUPPORTED	PERSDATA	609	I/O device type (from personality) not supported.
UI_FATAL_AUXIO_MALLOC_ERROR	SOFTWARE	610	Software memory error.
AEGIS_ADI_OVERFLOW	SOFTWARE	801	ADI Transmit event not serviced in time and buffer has overflowed.

Radio Programming Errors

Programming errors are divided into three categories:

1. Protocol Errors - These are errors produced by the low level communication routines.
2. Radio Errors - These are errors that are returned from the radio ROM or operating software.
3. PC Errors - These are errors that are produced by the PC Programming software.

MESSAGE	CODE	DESCRIPTION
Successful	0	Command was performed successfully.
Protocol - Canceled by receiver	5	x328 protocol received a cancel. The radio detected a cancel command.
Protocol - Canceled by sender	6	x 328 protocol transmitted cancel. The radio is canceling the read command.
Protocol - Terminate transmission	7	x328 protocol received an end of transmission.
Protocol - Transmit error	8	x328 protocol could not transmit. Reliable communication can not be established. It could be the radio or PC hardware problems (programming cable, interface box, or radio hardware).
Protocol - Protocol initialization error	9	x328 protocol not initialized or failed to initialize.
Radio - Programmed successfully	10	Radio responded with a success. Radio acknowledged successful programming.
Radio - Comport configuration failed	11	Radio could not configure its comport (hardware failure).
Radio - Flash erase failed	12	Radio failed to erase the flash memory. The radio flash memory part is unusable or it can not detect the 12 volts power. Check the programming box and cables.
Radio - Flash write failed	13	Radio failed in writing to the flash memory. Retry the programming process (hardware failure).
Radio - Flash code CRC did not match	14	Flash code not programmed correctly. CRC did not match. The operating software will not execute. Re-program the radio.
Radio - Canceled by receiver	15	The radio operating software received a cancel command.
Radio - Canceled by sender	16	
Radio - End of transmission received	17	The radio software received or sent an end of transmission.
Radio - Transmit error	18	Radio could not transmit the required data. Check all hardware connections and try programming again.
Radio - Invalid command	19	Radio did not understand the received command.
Radio - No application code	20	No application code is loaded, the radio can not accept personality commands. Re-program the operating software (flash code) and re-program the personality.
Radio - Application code error	21	The radio application code failed to perform the command.
Radio - EEPROM programming error	22	Could not program the radio EEPROM part.
Radio - Baud rate has changed	23	The radio acknowledged a successful baud communication baud rate change.
PC - Cannot allocate memory	50	The PC programming software could not allocate adequate memory space to perform the function.
PC - Cannot open data file	51	The specified file (code or personality) could not be opened (file does not exist or has access protection).
PC - Cannot read data file	52	The specified file (code or personality) could not be read.
PC - Cannot write to file	53	The specified file (code or personality) could not be written.
PC - File not found	54	The specified file (code or personality) in not found in the current directory.
PC - File is larger than radio memory	55	The radio flash part size is unknown or the operating software file size is larger than the radio's flash memory size.
PC - Incorrect Tracking Data RF band split	57	Incorrect Tracking Data RF band split.
PC - Incorrect Tracking Data version	58	Incorrect Tracking Data version.
PC - Tracking Data checksum error	59	Tracking Data checksum error.
PC - Time-out, radio not responding	60	Radio is not connected or not turned on or the selected PC comport number is invalid.
PC - Comport configuration error	61	Comport configuration error, can not set comport.
PC - Abort, message canceled	62	Aborted by operator, message canceled.
PC - Requested personality data does not exist	63	The personality table does not exist (Tracking or Encryption table).



Ericsson GE Mobile Communications Inc.
Mountain View Road • Lynchburg, Virginia 24502

Printed in U.S.A.