

Configuration Manual

EDACS[®] Single Channel Autonomous Trunking (SCAT) GETC Configuration Manual

REVISION HISTORY

REVISION	DATE	REASON FOR CHANGE
A	Oct-95	Updated to replace existing SCAT software with Release 5 Station GETC and Station Turbo software, 349A9607G5 and 344A4414G5. Also replaces SCAT Downlink software with Release 5 Link GETC and Link Turbo software, 344A4895G5 and 350A1121G5.
	May-94	Original

NOTICE!

This manual covers Ericsson and General Electric products manufactured and sold by **Ericsson Inc.**

NOTICE!

Repairs to this equipment should be made only by an authorized service technician or facility designated by the supplier. Any repairs, alterations or substitution of recommended parts made by the user to this equipment not approved by the manufacturer could void the user's authority to operate the equipment in addition to the manufacturer's warranty.

NOTICE!

The software contained in this device is copyrighted by **Ericsson Inc.** Unpublished rights are reserved under the copyright laws of the United States.

This manual is published by **Ericsson Inc.**, without any warranty. Improvements and changes to this manual necessitated by typographical errors, inaccuracies of current information, or improvements to programs and/or equipment, may be made by **Ericsson Inc.**, at any time and without notice. Such changes will be incorporated into new editions of this manual. No part of this manual may be reproduced or transmitted in any form or by any means, electronic or mechanical, including photocopying and recording, for any purpose, without the express written permission of **Ericsson Inc.**

EDACS and MASTR are registered trademarks, and GETC, Failsoft, Aegis, Guarddog, and ProSound are trademarks of **Ericsson Inc.**

TABLE OF CONTENTS

<u>Section/Paragraph</u>	<u>Page</u>
REVISION HISTORY	2
TABLE OF CONTENTS	3
LIST OF FIGURES	4
LIST OF TABLES	5
INTRODUCTION	6
DESCRIPTION	6
SOFTWARE UPGRADES	6
RELEASE 5 SOFTWARE	7
Feature Enhancements	7
Hardware Requirements	7
SCAT Data	7
RELATED PUBLICATIONS	8
SOFTWARE COMPATIBILITY	8
EDACS COMPATIBILITY	8
RADIO COMPATIBILITY	8
OPERATION	10
STAND-ALONE SCAT.....	10
NETWORK SCAT.....	10
SCAT and Downlink.....	11
Wide Area Digital Option	11
CONFIGURATION	12
EQUIPMENT REQUIRED	12
HARDWARE INSTALLATION	12
Stand-alone SCAT System	12
Network SCAT Option.....	12
Upgrading Hardware	13
GETC Logic Board Installation	13
Turbo Board Installation	13
Rockwell Modem Installation	13
Jumper Installation.....	14
GETC SOFTWARE INSTALLATION	16
SCAT Station GETC.....	16
De-installing The GETC-1e Software	16
Downlink GETC	17
TURBO BOARD SOFTWARE INSTALLATION.....	17
Equipment Required.....	17
PC Programmer Setup.....	18
PERSONALITY PROGRAMMING.....	19
Programming a Personality Using TQ-3357 V3 (or earlier).....	19
Programming a Personality Using TQ-3357 Version 4.03 (or later).....	20
SCAT Personality.....	23
OPERATIONAL CHECKOUT	24
DIP SWITCH SETTINGS.....	24

TABLE OF CONTENTS

<u>Section/Paragraph</u>	<u>Page</u>
SCAT Station GETC	24
SCAT Downlink GETC	24
CLEAR VOICE CHECKOUT	24
Locally Initiated Calls	24
Multisite Initiated Calls	25
DIGITAL VOICE CHECKOUT	25
Locally Initiated Calls	25
Multisite Initiated Calls	25
LED Indicators	26
TROUBLESHOOTING	26
DOWNLINK ACTIVITY LOGGER	26
IN CASE OF DIFFICULTY	26
INTERCONNECT DIAGRAM.....	27
PARTS LIST.....	30
GETC CABLE 19C336863G1	30
CABLES AND HARNESSES.....	31

LIST OF FIGURES

<u>Figure</u>	<u>Title</u>	<u>Page</u>
Figure 2 -	Stand-alone SCAT	10
Figure 1 -	Network SCAT Station.....	10
Figure 3 -	Downlink to CEC/IMC Communication	11
Figure 4 -	SCAT to Downlink Communication	11
Figure 5 -	GETC Phone Line Level Adjustments	13
Figure 6 -	Station GETC (19D904266) Jumper and Test Point Locations.....	15
Figure 7 -	System Hook-Up Using J100.....	19
Figure 8 -	Programming DIP Switch Settings	20
Figure 9 -	System Hook-Up Using J104.....	20
Figure 10 -	Typical SCAT Station DIP Switch Settings	24

LIST OF TABLES

<u>Table</u>	<u>Title</u>	<u>Page</u>
Table 1 - New Software Releases.....		7
Table 2 - EDACS Component Software Compatibility		9
Table 3 - Radio Compatibility		9
Table 4 - Indicators in Programming Mode Using J100.....		20
Table 5 - Indicators in Programming Mode Using J104.....		20
Table 6 - Sample Station Personality.....		21
Table 7 - SCAT Station GETC, CC Mode.....		24
Table 8 - LED Indications, Clear Voice Local Call.....		25
Table 9 - LED Indications, Clear Voice Multisite Call		25
Table 10 - LED Indications, Digital Voice Local Call		25
Table 11 - LED Indications, Digital Voice Multisite Call		25
Table 12 - LED Indications, Summary		26

INTRODUCTION

This manual provides instructions for configuring the Ericsson **GE** Trunking Card (**GETC**) for use in a **Single Channel Autonomous Trunking (SCAT)** station. The information presented in this manual is applicable to EDACS SCAT stations using the MASTR II, IIe or MASTR III repeaters. The manual provides instructions for installing the SCAT Station GETC hardware and software, Turbo software, and programming the system's personality. It also provides instructions for performing a functional checkout of the GETC's.

DESCRIPTION

SCAT is a unique application of a GETC shelf that is configured as an option to an EDACS Repeater. The SCAT option allows a single repeater to alternately perform the Control Channel or Working Channel functions. This extends the trunked operation into difficult areas such as ravines, tunnels, etc. and extremely low traffic density areas such as shopping malls.

SCAT systems are available for all EDACS wideband configurations: VHF, UHF, and 800 MHz.

The SCAT channel may be configured as stand-alone system or as part of a multisite trunking network.

The SCAT Station GETC uses a Lightning GETC (GETC1e) platform 19D901868G3 or G4 consisting of the following sub-assemblies:

SCAT Station GETC:

- Logic Board 19D904266G1 (used with Group 3 shelf) or 19D904266G4 (used with Group 4 shelf).
- GETC Expansion Module (Turbo Board) 19D903536P1.
- Regulator Board 19C366861G2.
- Rockwell Modem 19A705178P1 (optional). (The modem is required when the SCAT Station is setup to use the Wide Area Digital option.)
- Software:
GETC - 349A9607G5 Ver. 5.04 (EPROM media)
Turbo - 344A4414G5 Ver. 5.01 (diskette media)

NOTE

GETCs using Logic Board 19D904266G1 with Group 5 station software must be upgraded with the *Speedy* (80C320) microprocessor and Amps Modem chips, U4 and U19 (19A704727P4). A FerriShield Toroid (REG70469/1) must also be installed around the Turbo Board's harness. (Refer to *Upgrading Hardware* section of this manual.)

SCAT Downlink GETC:

- Logic Board 19D904266G1 (used with Group 3 shelf) or 19D904266G4 (used with Group 4 shelf).
- GETC Expansion Module (Turbo Board) 19D903536P1.
- Regulator Board 19C366861G2.
- Rockwell Modem 19A705178P1.
- Software:
GETC - 344A4895G5 Ver. 5.01 (EPROM media)
Turbo - 350A1121G5 Ver. 5.01 (diskette media)
- SCAT Interconnect Cable 19C337102P1.

NOTE

In MASTR III systems, a cable (19D903880P10) is added to allow easy access to the MIII Tx and Rx Audio (J101). This cable is routed from the MIII Interface Board J101 to the Downlink GETC TB10 pins 1, 2, 3, and 4.

SOFTWARE UPGRADES

The GETC software product is continuously being improved and upgraded to include new features. The following paragraphs provide brief descriptions of the new features introduced by recent software releases. Information is also provided when hardware or software issues affect the GETC's configuration.

For a complete description of the new or enhanced features and its use, refer to Software Release Notes (SRN) for the specific software release. In example, for 349A9607G4 software refer to SRN1060-4, For 349A9607G5 software refer to SRN1060-5, etc.

RELEASE 5 SOFTWARE

Upgrading the GETC Station software 349A9607G5 adds SCAT functionality to the standard Station GETC platform. As a result, it is no longer necessary to replace the Station GETC software with unique SCAT GETC software.

Feature Enhancements

The Release 5 GETC1e software adds SCAT Data, ProSound, Enhanced Multisite Login, and Voted Digital Interconnect (VDI) features. The SCAT operating mode will acquire many of these new features. These features are activated in the GETC personality using the GETC1e PC Programmer TQ-3357 V4.03 (with Field Macro "gtc_9505.mac") or V5.0.

Another significant change is the SCAT Downlink GETC software being replaced by standard Link GETC software.

The specific software changes are listed in Table 1:

Table 1 - New Software Releases

SOFTWARE PURPOSE	PREVIOUS SOFTWARE	RELEASE 5 SOFTWARE
SCAT Station GETC (EPROM)	344A3835G2 (SRN1009)	349A9607G5 (SRN1060)
SCAT Station GETC Turbo Software (diskette)	344A4414G2 (SRN1062)	344A4414G5 (SRN1062)
SCAT Downlink GETC (EPROM)	344A3835G2 (SRN1009)	344A4895G5 (SRN1061)
SCAT Downlink Turbo Software (diskette)	344A4414G2 (SRN1062)	350A1121G5 (SRN1061)

Hardware Requirements

When upgrading to the 349A9607G5 Station GETC software, the 19D901868G3 GETC must have the "speedy" microprocessor modification installed. Systems using the 19D901868G4 GETC platform include the "speedy" microprocessor. Refer to the *Upgrading Hardware* section for details.

SCAT Data

The Group 5 software release adds the SCAT RF and Landline Data functions.

Configuration Considerations:

- Radio users must have SCAT options enabled.
- When selecting Landline data, a Rockwell modem must be installed and EDG must be set up (refer to EDG documentation).
- Configuration requires using PC Programmer V4.03 and Field Macro "gtc_9505.mac" to access applicable parameters.

NOTE

Only PC Programmer TQ-3357 V4.03 (or later) can be upgraded through the use of Field Macros. New Field Macros may be downloaded from the accompanying Station Turbo Software distribution disk or from Ericsson's "One1Call" Electronic Information Retrieval system.

RELATED PUBLICATIONS

It may be necessary to consult one or more of the following documents during the installation process. These manuals will also provide additional guidance if you encounter technical difficulties during the configuration process.

- LBI-38430 - MASTR Iie Control Shelf Maintenance Manual.
- LBI-38636 - MASTR III Base Station Installation Manual.
- LBI-38822 - Turbo Board (GETC1e) Maintenance Manual.
- LBI-38894 - GETC Trunking Card Maintenance Manual.
- LBI-38896 - EDACS Site Downlink and CEC/IMC Uplink Configuration Manual.
- LBI-38988 - EDACS Station GETC1e Configuration Manual.
- LBI-39149 - EDACS Compact Vertical Voter Maintenance Manual.
- LBI-39186 - EDACS Simulcast Control Point Maintenance Manual.
- LBI-39187 - EDACS Voted Digital Interconnect Configuration Manual.
- SRN-1009 - Software Release Notes for GETC SCAT Software344A3835G2
- SRN-1010 - Software Release Notes for GETC Turbo Board Software, 344A4414G1 only.
- SRN-1060 - Software Release Notes for GETC1e Software, 349A9607G1 (or later).
- SRN-1061 - Software Release Notes for Link Software, 344A4895G1 (or later) and Link Turbo Software 350A1121G4 (or later).
- SRN-1062 - Software Release Notes for Turbo Board with GETC1e Software, 344A4414G2 (or later).
- TQ-3357 - GETC Shelf Programming Manual

SOFTWARE COMPATIBILITY

EDACS COMPATIBILITY

The data presented in Table 2 represents the minimum EDACS component software versions required to support the Release 5 software features.

RADIO COMPATIBILITY

SCAT operation can only be performed by radios equipped to use a SCAT channel.

Table 3 describes the minimum software requirements for radio products supporting the features included in Release 5 software.

Table 2 - EDACS Component Software Compatibility

EDACS COMPONENT	Required for SCAT Data	Required for Enhanced Multisite Login	Required for ProSound	Required for Voted Digital Interconnect	Required for Failsoft Patch Operation
C3 MAESTRO	N/A	344A3922G4	344A3922G4	344A3922G4	344A3922G4
IMC U58	344A3567G11	344A3567G8	344A3567G11	344A3567G11	344A3567G11
U59	344A3568G11	344A3568G8	344A3568G11	344A3568G11	344A3568G11
U3	344A3565G11	344A3565G7	344A3565G11	344A3565G11	344A3565G11
MOM	344A3630G11	344A3630G4	344A3630G11	344A3630G11	344A3630G11
Site Controller	N/A	344A3265G3	344A3265G6	344A3265G6	344A3265G2
VAX System Manager	344A4583G2	344A4583G2	344A4583G2	344A4583G2	344A4583G2
PDP System Manager	19A149495G8	19A149495G8	19A149495G8	19A149495G8	19A149495G8
Link GETC	344A4895G5	N/A	344A4895G5	344A4895G5	344A4895G4
Link Turbo	350A1121G5		350A1121G5	350A1121G5	350A1121G4
PC Programmer TQ-3357	Ver 4.03	Ver 4.03 (gtc_9505.mac)	Ver 4.03	Ver 4.03	Ver 4.03
Voter / Simulcast	N/A	19A149567G12	19A149567G12	19A149567G13	19A149567G12
Jessica PI	N/A	N/A	N/A	349A9982G3	349A9982G3
EDG Application 147 ROMs VC24 ROMs	350A1069G1 350A1101G1 350A1072G1	N/A	N/A	N/A	N/A

Table 3 - Radio Compatibility

FEATURE	MPA	MDX	MDR	MRK	ORION	Alpha FMD
ProSound	G15	G9	G8	G22	G22	N/A
Enhanced Multisite Login	G16	G10	N/A	G22	G22	G2
Modified Data Protocol	N/A	G10	N/A	G19	G19	G2
SCAT	G8	G1	G1	G19	G19	G1
SCAT Data	N/A	G10	N/A	G22	G22	G2
Interconnect	G10	G1	G1	G1	G1	G1
Digital Interconnect	G12	G1	N/A	G5	G1	G1

OPERATION

STAND-ALONE SCAT

The stand-alone SCAT consists of a standard EDACS Station as shown in Figure 1, with the GETC personality configured for SCAT operation (special SCAT software 344A3835G2 required prior to release 5). In this configuration, the repeater transmits Control Channel information until a radio requests a channel. The SCAT repeater then assigns itself as the Working Channel and begins routing audio. When the call is complete, the SCAT channel resumes operating as the Control Channel.

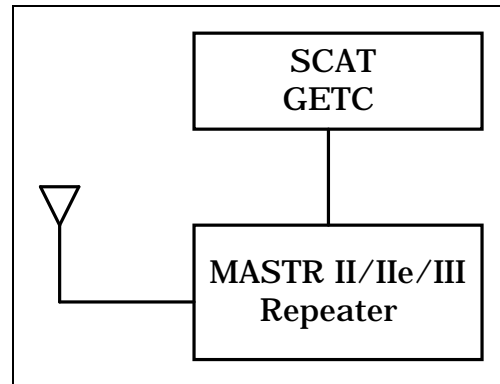

Figure 1 - Stand-alone SCAT

NETWORK SCAT

The second configuration is a Network SCAT channel used as part of an EDACS Multisite system. In this configuration, the SCAT station is connected to the Console Electronics Controller or Integrated Multisite and Console Controller (CEC/IMC) as shown in Figure 2. Each SCAT channel has its own Downlink and audio/data interface into the CEC/IMC.

The Network SCAT channel configuration requires a standard EDACS station with the SCAT option (XXCP3Y). This option adds a SCAT Downlink GETC and a SCAT interconnect cable to link the SCAT Station GETC to the Downlink GETC. Prior to release 5, the option also included SCAT software (344A3835G2) which was installed in both the SCAT Station GETC and the SCAT Downlink GETC. With release 5, the system uses a standard Station GETC (with "speedy" processor upgrade) and standard Link GETC with personalities setup for SCAT operation.

The CEC/IMC controls and routes SCAT calls, allowing the user to enjoy trunking features and the same trunked user interface. The CEC/IMC must be configured with a site interface (MSZM3R) for the SCAT system.

As a result of the SCAT station using only one channel, only one conversation can occur at any one time through the SCAT site. While the SCAT site is busy, every call request (mobile request or console request) is queued. The mobile radio generates the Call Hold Off queue tone and automatically places a call request upon completion of the first call. Only console request for the active group will be processed immediately.

The SCAT channel and SCAT radios are designed to minimize the overloading of the inbound SCAT channel by prioritizing all calls. This allows the system to respond to emergency calls immediately upon availability of the channel.

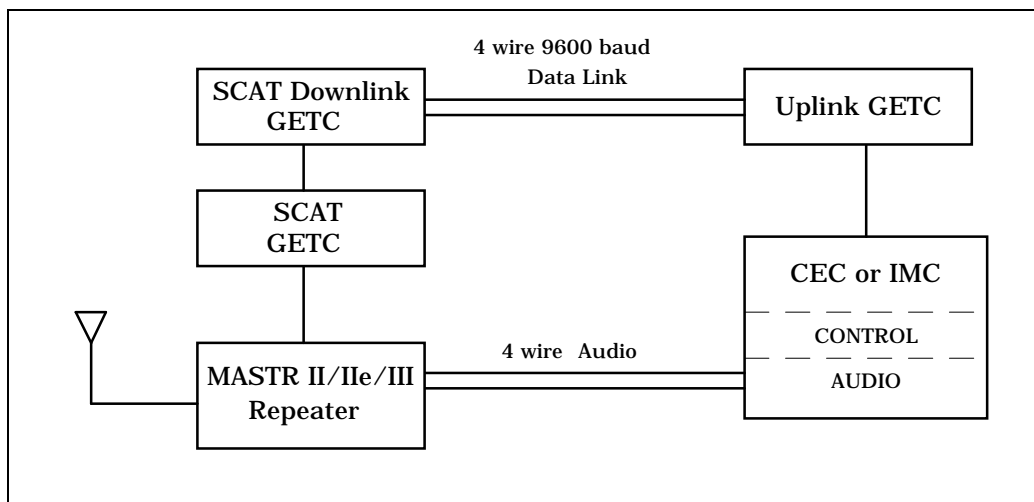

Figure 2 - Network SCAT Station

Except for interconnect calls, all group and individual calls appear as transmission trunked calls to the radio and the CEC/IMC. This assures the mobile's quick return to the Control Channel. Local interconnect is unavailable on SCAT sites. However, use of the Centralized Telephone Interconnect System (CTIS or Jessica) is available in the multisite configuration.

SCAT and Downlink

The SCAT Station GETC provides the control functions necessary to implement EDACS access to the SCAT service area. The Downlink is essentially a message conduit providing a data communication path between the SCAT station and the CEC/IMC.

The Downlink's modem data is synchronous at 9600 baud using the full duplex operating mode. Data flows simultaneously in both directions as illustrated in Figure 3.

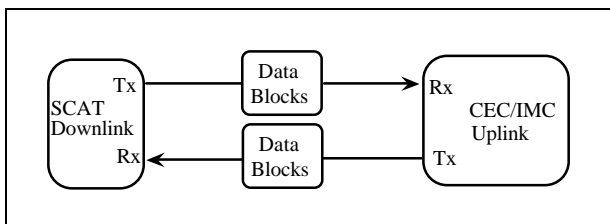

Figure 3 - Downlink to CEC/IMC Communication

The SCAT to Downlink format is asynchronous at 19.2K baud using the half duplex operating mode. Data flows in one direction at a time as shown in Figure 4.

Since these two protocols are different, the Downlink converts from one format to the other. In addition, both the SCAT and Downlink perform data error detection and

correction, general control of timer and IO functions (DIP switch, LED's, UART's, etc.), receive and transmit buffer management, message scheduling, and Turbo interfacing.

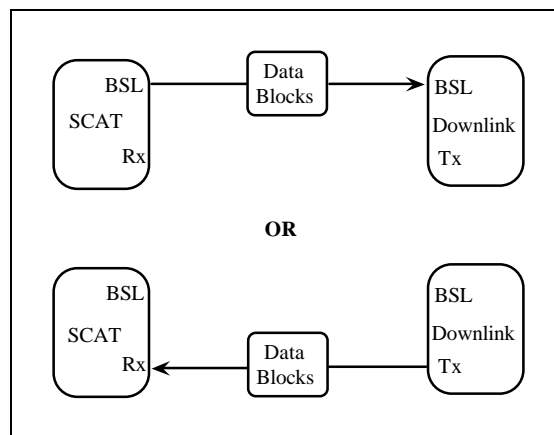

Figure 4 - SCAT to Downlink Communication

Wide Area Digital Option

The Wide Area Digital option (SXS7A) enables the SCAT station to support Digital Voice communications. A hardware option (SXMD1D) provides an additional Rockwell Modem for the SCAT Station GETC. This enables the SCAT Station GETC to send and receive 9600 baud digital voice to the CEC/IMC using the four wire audio line.

NOTE

The SCAT software must be 344A3835G2 or 349A9607G5 (or later) to support Digital Voice communications.

CONFIGURATION

The scat configuration process involves the following procedures and should be completed in the order presented:

1. Hardware Installation - The Hardware Installation procedure verifies proper installation of GETC hardware.
2. GETC Software Installation - The GETC Software Installation procedure provides instructions for installing the GETC operating software.
3. Turbo Board Software Installation - This procedure provides instructions for installing the Turbo Board software.
4. Personality Programming - This procedure provides instructions for programming and storing system configuration data in the GETC.
5. Operational Checkout - The Operational Checkout procedure provides instructions for verifying the GETC operation when the configuration is complete.

NOTE

When interfacing the SCAT system into a network, refer to LBI-38896 for the Downlink GETC configuration instructions.

is mounted within a slide out shelf measuring 1.75 inches high (one rack unit) by 19 inches wide.

Installation or removal of the shelf sub-assemblies involves sliding the GETC shelf out of the cabinet and into the service position. This position allows access to the shelf's sub-assemblies. Refer to the MASTR II, IIe, or MASTR III Application Assembly Diagrams for detailed information on installing the GETC Shelf.

Stand-alone SCAT System

The Stand-alone SCAT system is based on a standard EDACS Station GETC using 349A9607G5 Station GETC software with 344A4414G5 Turbo software. Earlier SCAT systems required replacing the station GETC software with unique SCAT software 344A3835G2.

NOTE

Systems upgrading to Group 5 software and using GETC Logic Board 19D904266G1 must be upgraded with the *Speedy* (80C320) microprocessor and Amps Modem chips, U4 and U19 (19A704727P4). (Refer to *Upgrading Hardware* section of this manual.)

A FerriShield Toroid (REG70469/1) must also be installed around the Turbo Board's harness for EMI suppression, refer to LBI-38822 for details.

EQUIPMENT REQUIRED

The following equipment and software may be required to configure the GETC:

- IBM compatible PC with at least 640K memory, monitor, and keyboard.
- Hard disk is recommended; but, not required.
- Serial Port configured as either COM1 or COM2.
- TQ-3360 programming cable.
- Male DB-25 to female DB-9 adapter.
- Software distribution diskette 344A4414.
- Oscilloscope.

HARDWARE INSTALLATION

Typically, a Station GETC is installed in the station cabinet just above the station's radio assembly. The GETC

Network SCAT Option

SCAT systems integrated into a multisite network require adding a Downlink GETC using 344A4895G5 GETC software and 350A1121G5 Link Turbo software. Earlier SCAT systems replaced the standard software with unique SCAT software 344A3835G2. In addition, a special interconnect cable must be installed between the Station GETC and the Downlink GETC.

The Network SCAT option consists of a Downlink GETC, a GETC interconnect cable. The interconnect cable provides the connection from the Station GETC to the Downlink GETC using their Backup Serial Ports. Both the Station and Downlink GETCs are configured with a Turbo Board for additional memory and processing capability.

Data communication between the Downlink GETC and the CEC/IMC Uplink GETC is carried on a four-wire, data grade, type 3002 audio circuit. As shown in Figure 3, the SCAT Site is configured as a dedicated site connected to the CEC/IMC through the Uplink GETC. Therefore, the maximum number of SCAT channels on a multisite network is equal to the maximum number of sites allowed on the CEC/IMC.

Upgrading Hardware

GETC Shelves 19D901868G3 which are upgrading to the 349A9607G5 software must ensure their hardware is upgraded to the proper level. (The 19D901868G4 GETC Shelf meets all Release 5 requirements.)

Upgrading the hardware involves three elements:

- The microprocessor U1, 19A705557P1 (80C32), is replaced with a faster “Speedy” microprocessor RYT 121 6060/A (80C320).
- Replacing the AMPS modem chips U4 and U19 with the TI AMPS modem chips 19A704727P4.
- Installing a Ferrite Toroid on the Turbo Board harness to suppress EMI spurs at 74 MHz.

The replacement microprocessor and Ferrite Toroid are available in the field installable upgrade kit SPK9505. If replacement of the modem chips is necessary, they must be ordered separately. Refer to LBI-38894 and LBI-38822 for complete installation instructions.

GETC Logic Board Installation

This manual assumes the GETC Logic Board (19D904266G1 or G4) is previously installed, setup for the default configuration (Wideband EDACS Station), and

fully operational. If you suspect that the GETC Logic board is not operating properly, refer to the Troubleshooting section in this manual.

Turbo Board Installation

This manual assumes the Turbo Board is previously installed and fully functional. If, after installing or attempting to install the Turbo Software, the Turbo Board is not functioning properly, refer to the Troubleshooting section. Additional maintenance information is also available in LBI-38822, SRN1060 and SRN1062.

Rockwell Modem Installation

The Rockwell Modem provides a high speed synchronous serial interface between the Downlink GETC and the CEC/IMC’s Uplink GETC. The Station GETC uses the modem to send and receive serial digital data representing GID information, polling messages, keying messages, and channel assignments. Data transfer rates are 9600 bits per second (bps) using dedicated 3002 data grade four-wire audio lines. Technical specifications for the modem may be found in LBI-33031. Information on installing and testing the modem may be found in LBI-38894, and LBI-38822.

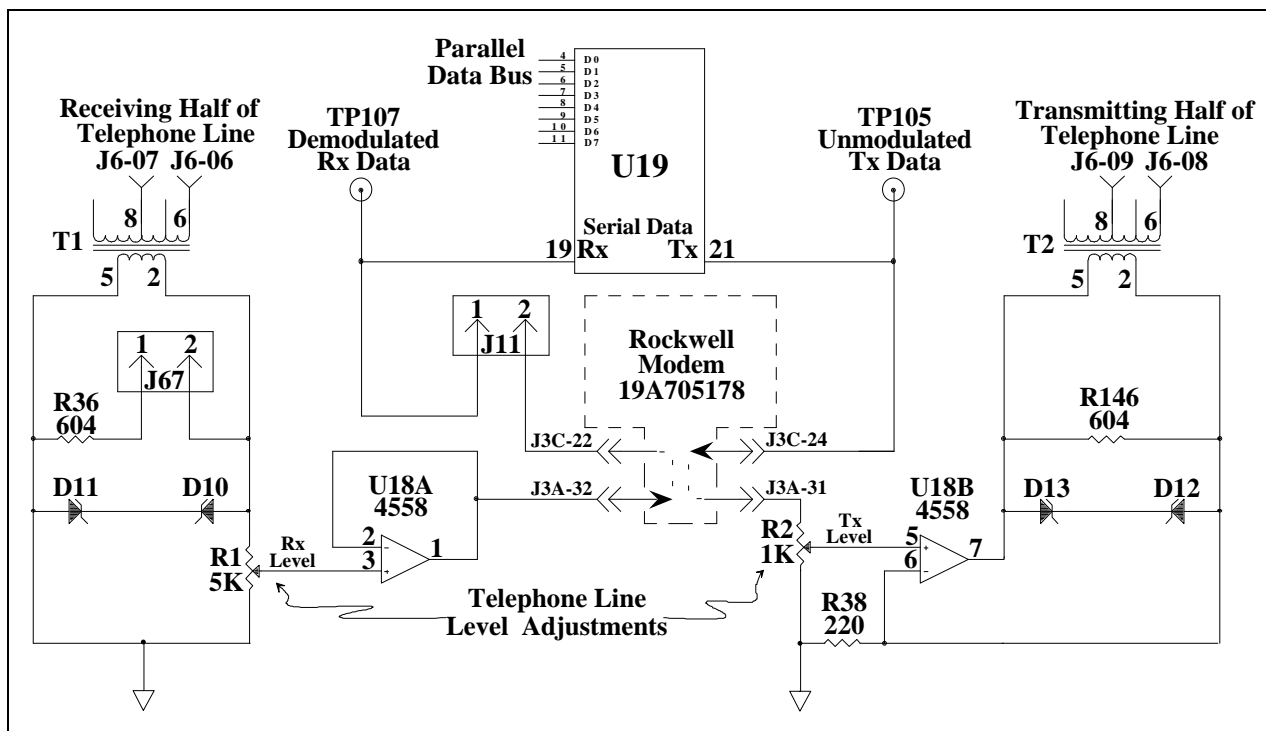

Figure 5 - GETC Phone Line Level Adjustments

Use the following procedure to install the modem if it is not already installed:

NOTE

If the SCAT station is setup to use the Wide Area Digital option, a Rockwell Modem must also be installed in the Station GETC. This allows the station to send and receive digital information to the CEC/IMC through the audio path.

Use the following steps to set up the basic audio line levels. If the Station GETC is linked to a MultiSite system other than the CEC/IMC (i.e. Data Gateway), different levels may be required. Consult the applicable system installation manual for the required levels.

1. Ensure jumpers are installed on J11 pins 1 & 2 and J12 pins 1 & 2.
2. Apply power to the GETC.
3. Adjust the receive level by monitoring U18 pin 1 (refer to Figures 5 and 6) and adjusting the receive level potentiometer R1 (located on the GETC Logic Board) for 400 mVpp as measured with an oscilloscope (85 mVrms if using an RMS Voltmeter).
4. Verify the presence of demodulated signal data at TP107.
5. Adjust the transmit level potentiometer R2 for the maximum output level allowed by the phone line, microwave link, or equivalent communication line. For telephone lines linking the Station GETC to the CEC/IMC Uplink GETC, adjust R2 for .77 Vrms (0 dBm) measured across J6-8 and J6-9 (TB10-1 and 2). For microwave links, adjust R2 for -10 dBm across J6-8 and J6-9.
6. Initialize the modem by pressing S4 (on the GETC Logic Board) to reset the Station GETC or cycle the GETC Shelf's operating power.

Jumper Installation

There are a few jumpers on the GETC Logic Board which must be re-configured for different applications. To properly configure the GETC jumpers, refer to jumper tables in SRN1060 or SRN1061 and install or remove jumpers according to the intended GETC application. The location of the jumpers may be found using the board layout diagram in Figure 6.

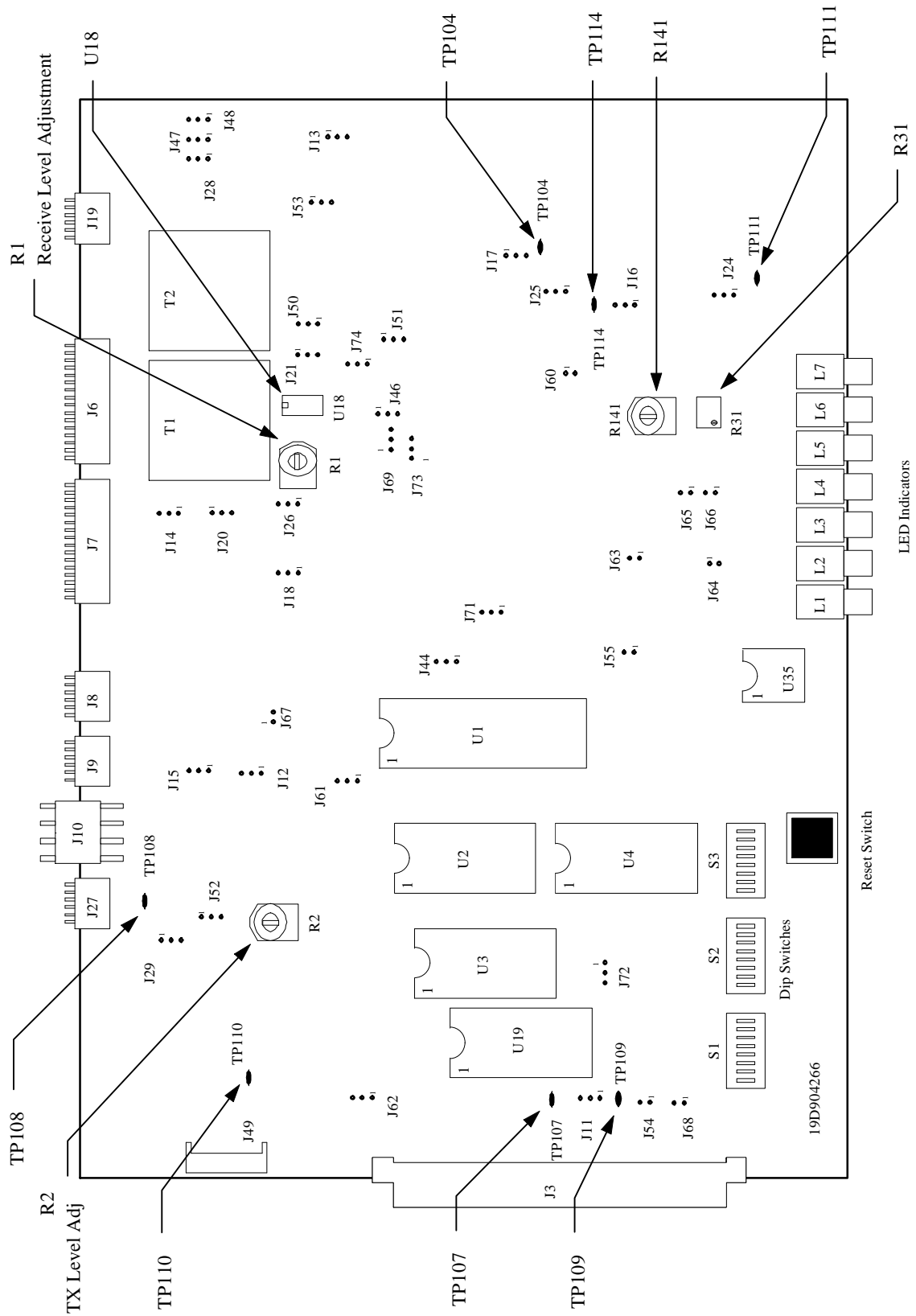

Figure 6 - Station GETC (19D904266) Jumper and Test Point Locations

GETC SOFTWARE INSTALLATION

The GETC software installation procedure involves installing the latest version of the EPROM containing the GETC operating software.

NOTE

Download applicable Field Macros into the PC Programmer TQ-3357 prior to configuring the GETC software.

SCAT Station GETC

The following procedures provide instructions for installing the GETC software 349A9607G5 into the SCAT Station GETC:

CAUTION



Observe precautions
for handling
**ELECTROSTATIC
SENSITIVE DEVICES**

NOTE

Upgrading to Release 5 software is backward compatible in functionality with 344A3835G2 software. However, GETCs using the 19D904266G1 Logic Board must be upgraded to the 80C320 microprocessor (U1), and 19A704727P4 Modem (U4 & U19).

The Turbo Board using 344A4414G5 software must also be upgraded to include a Ferrite Toroid.

Refer to the *Upgrading Hardware* section for details.

1. Power down the channel and place the GETC into the service position. Refer to LBI-38894 if necessary.
2. If the Turbo Board is not installed, remove RAM chip U3 and install Turbo Board. Refer to LBI-38822 for instructions.
3. Ensure Modem chips U4 and U19 are TI AMPS modems 19A704272P4. TI Amps modems are required when upgrading to 349A9607G5, replace if necessary.
4. Ensure microprocessor U1 is the “Speedy” microprocessor 80C320 (RYT 121 6060/A). This processor is required when upgrading the software to 349A9607G5. The processor is available in the Speedy Upgrade Kit SPK9505. Replace if necessary. Refer to LBI-38894 for installation instructions.
5. Ensure Turbo Board harness has Ferrite Toroid installed. Toroid is included in the SPK9505 Speedy Upgrade Kit. Replace if necessary. Refer to LBI-38822 for installation instructions.
6. Remove the old EPROM (U2) from the GETC Logic Board.
7. Install the new EPROM into the XU2 socket, being sure to properly orient the chip.
8. Remove EEPROM U35, if necessary, from the Logic Board. The GETC personality will reside in the Turbo Board and this device is no longer required.
9. Power up the channel.
10. Place the Turbo processors U1 and U2 in the program mode by switching Turbo Board switches S2 and S3 toward the front of the Turbo Board.
11. Download the Turbo Board Software from the disk provided in the Turbo Media Kit, 344A4414. Refer the *Turbo Board Software Installation* section, SRN1060, SRN1062, and LBI-38822.
12. After downloading the Turbo Board software, move switches S2 and S3 toward the back of the Turbo Board and press the GETC Logic Board Reset button, S4.
13. The two LEDs on the Turbo Board should light.
14. Program the GETC’s personality using the *Personality Programming* procedures contained in this manual and the detailed instructions contained in TQ-3357 and SRN1060.
15. Verify system performance using the *Operational Checkout* procedures.

De-installing The GETC-1e Software

If a problem arises while upgrading or installing the new software, it may be necessary to de-install the software. Restoring the site to its original configuration will depend on the original hardware platform. The two cases are described below.

If the original equipment configuration was a GETC1e (GETC with Turbo) platform, then perform the following steps:

1. Replace Group 5 GETC PROM with original software.
2. Reload original Turbo software using PC Programmer.
3. If changes were made to the personality, then reload the previous parameters.
4. The Speedy microprocessor upgrade, if installed, does not need to be reversed.

If the original equipment was a GETC (GETC with no Turbo) platform, then perform the following steps::

1. Replace Group 5 GETC PROM with original software.
2. Disable the Turbo by sliding Turbo switches S2 and S3 toward the front of the GETC shelf.
3. Re-install the original personality EEPROM, if it was removed, else no change.
4. The Turbo upgrade, if installed, does **not** need to be reversed.
5. Re-install the original microprocessor. The Speedy microprocessor upgrade is not compatible with original 344A3835 software.

Downlink GETC

When configuring the SCAT station’s Downlink GETC, refer to LBI-38896.

NOTE

When the SCAT Station GETC is upgraded to 349A9607G5 software, the SCAT Downlink GETC software 344A3835G2 with Turbo Board software 344A4414G2 must be replaced by Link software 344A4895G5 with Link Turbo software 350A1121G5, respectively. Refer to LBI-38896, Downlink GETC Configuration Manual for details.

TURBO BOARD SOFTWARE INSTALLATION

This procedure provides instructions for downloading the Turbo software. The software is included in the Turbo Media Kit, 344A4414. The installation process involves downloading the GETC1E utilities to an IBM compatible

personal computer (PC), and connecting the programming cable (TQ-3360) between the PC and the Turbo Board programming connector.

When using PC Programmer TQ-3357 V3 (or earlier) and downloading 344A4414G3 (and earlier) software, the data from the PC files is routed to the Turbo Board microprocessors through Turbo Board programming connector J100 at the rear of the GETC Shelf.

When using PC Programmer TQ-3357 V4.03 (or later), the Turbo software is downloaded to the Turbo Board microprocessors through Turbo Board programming connector J104. Programming through J104 also allows you to load the GETC personality without changing setups. In addition, the V4.03 PC Programmer will diagnose any problems between the PC and the GETC during the downloading process and simplify the handling and archiving of the Turbo software.

NOTE

PC Programmer TQ-3357 V4.03 must be used when upgrading to 349A9607G5 (or later). Only TQ-3357 V4.03 (or later) is capable of using Field Macros. When using 349A9607G5 software, the Field Macro “**gtc_9505.mac**” must be installed into TQ-3357 to access the new features’ parameters.

Equipment Required

- IBM PC/XT/AT or compatible with at least 640K memory, monitor and keyboard running MS-DOS version 3.0 or higher.
- Hard disk is recommended; but, not required.
- Serial Port configured as either COM1 or COM2.
- TQ-3360 programming cable.
- Male DB-25 to female DB-9 adapter or cable if the PC’s serial port connector is a male DB-9 connector instead of a male DB-25 connector.
- Station Turbo Software distribution diskette 344A4414G5 required when installing 349A9607G5 GETC Software). Refer to SRN1060 and SRN1062 to verify software compatibility.
- Field Macro “**gtc_9505.mac**” (supplied with the Station Turbo Software distribution disk).

PC Programmer Setup

Prepare the PC for programming the GETC Turbo Board by performing the following steps:

TQ-3357 V4.03 (or later)

1. Connect the TQ-3360 programming cable from the PC's serial port connector to the GETC Shelf connector J104 (A DB-25 to DB-9 adapter may be needed.)
2. Using the TQ-3357's LOAD utility, copy the Station Turbo software (344A4414) into the PC Programmer's working directories.
3. Load the Field Macro "gtc_9505.mac" into the TQ-3357 PC Programmer using the instructions contained in Chapter 5 of the TQ-3357 manual.
4. Refer to TQ-3357 Chapter 5 *LoadIE Utility* for complete instructions on downloading the Turbo software .

TQ-3357 V3 (or earlier)

1. Connect the TQ-3360 programming cable from the PC's serial port connector to the GETC Shelf connector J100 (A DB-25 to DB-9 adapter may be needed.)

2. Using standard DOS commands or a software file manager, create a directory named "**LOADIE**" on the PC's hard drive.
3. Make "**LOADIE**" the current directory and copy the following files from the software diskette into the "**LOADIE**" directory:
 - load1e.exe
 - letop.hex
 - lecrc.hex
 - lebot.hex
4. Run the **load1e.exe** program. Follow the on screen instructions and program the Turbo Board. Additional programming instructions may be found in SRN1062 and LBI-38822.

NOTE

When using Turbo Board 344A4414 Group 2 (or later) software, re-programming the GETC Turbo Board will not alter previously stored Personality Data. When Personality Data is present, "**load1e.exe**" clears and performs CRC functions over the code portion of memory only.

PERSONALITY PROGRAMMING

Personality refers to the system configuration data stored in the GETC's memory. The GETC's Personality includes system configuration information such as channel frequencies, call parameters, operating modes, and identification information.

The Personality Programming process involves using the TQ-3357 GETC Shelf PC Programmer which includes the programming software to create the desired personality and transfer the Personality data to the battery backed-up RAM located on the Turbo Board.

NOTE

If installing GETC software 349A9607G5 (or later), PC Programmer TQ-3357 V5.0 or V4.03 with Field Macro file "gtc_9505.mac" is required to access 349A9607G5 features' parameters.

The TQ-3357 V4.03 (or later) also allows you to upload the GETC's Personality without changing the DIP switch settings.

NOTE

It is not necessary to recreate the personality when upgrading from 344A3835G2 software to 349A9607G5 except when upgrading non-turbo platforms.

To activate new features, read the existing personality and edit the personality as required.

Programming a Personality Using TQ-3357 V3 (or earlier)

When using TQ-3357 Version 3 (or earlier) you must program the personality through J100.

1. Connect one end of the serial programming cable (TQ-3360) to the computer. Connect the other end of the serial cable to the GETC Shelf connector J100, see Figure 7.
2. Set the GETC DIP switches S1, S2, and S3 for the programming mode as shown in Figure 8. Set S2-8, S3-3 and S3-6 to OPEN. All other S3 positions should be CLOSED. Switches S1-1 thru S2-7 can be in any position and need not be changed. DIP switches S1-S3 are located near the front of the GETC Shelf, see Figure 6.
3. Reset the GETC by either applying power or pressing the GETC RESET switch S4, see Figure 6, located just below the DIP switches. Resetting the GETC, in

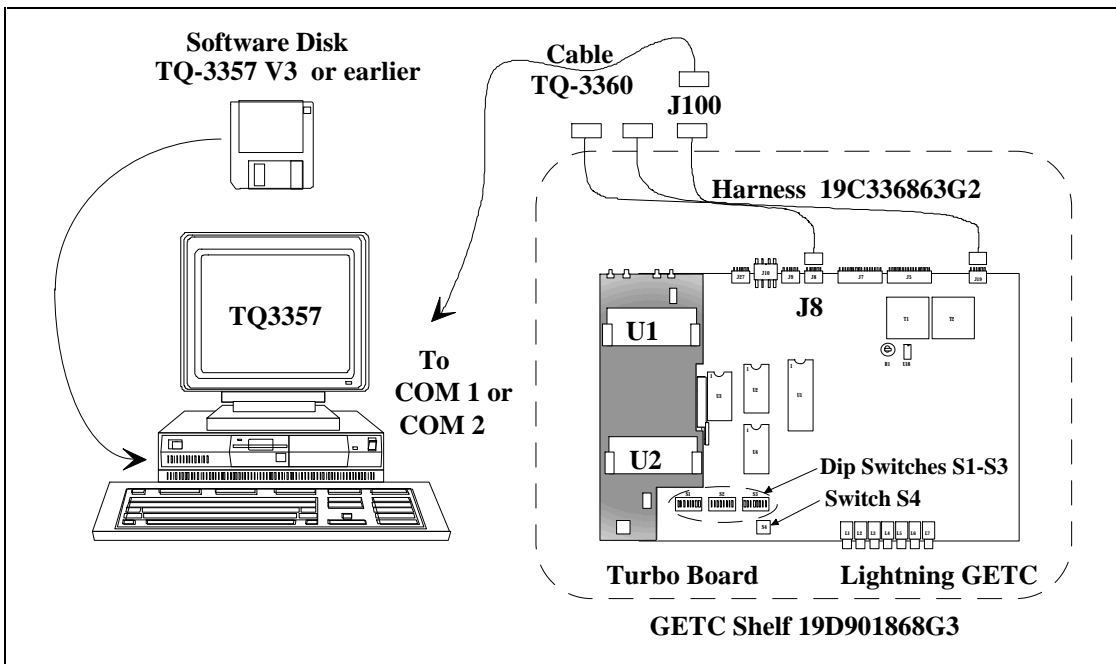

Figure 7 - System Hook-Up Using J100

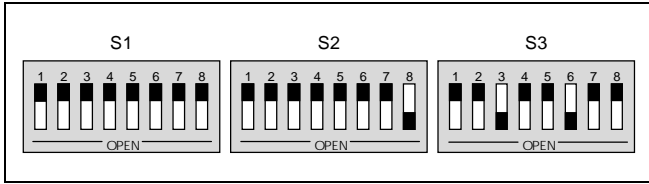

Figure 8 - Programming DIP Switch Settings

combination with the DIP switch settings, places the GETC into the Personality Programming mode.

- Verify that front panel LEDs L3, L4, and L5 are ON, as shown in Table 4. This indicates the GETC is ready for programming.

Table 4 - Indicators in Programming Mode Using J100

LED Indicators	L1	L2	L3	L4	L5	L6	L7
Programming Mode	○	○	●	●	●	○	○

Legend: ○ = OFF ● = ON * = FLASHING

- Review the SCAT Personality section in the manual and proceed with the Personality programming as described in TQ-3357 Chapter 4.
- After saving the personality and downloading it into the GETC, perform an operational checkout of the GETC.

Programming a Personality Using TQ-3357 Version 4.03 (or later)

When using TQ-3357 Version 4.03 (or later), program the personality through J104.

- Connect one end of the serial programming cable (TQ-3360) to the computer. Connect the other end of the cable to the GETC Shelf connector J104. See Figure 9.
- Move Switch S2 on the Turbo Board to the front placing the GETC into the Personality Programming mode. See Figure 9.
- Verify that front panel LEDs L6 and L7 are flashing, as shown in Table 5. This indicates the GETC is ready for programming.

Table 5 - Indicators in Programming Mode Using J104

LED Indicators	L1	L2	L3	L4	L5	L6	L7
Programming Mode	○	○	○	○	○	*	*

Legend: ○ = OFF ● = ON * = FLASHING

- Review the SCAT Personality section in the manual and proceed with the Personality programming as described in TQ-3357 Chapter 4.

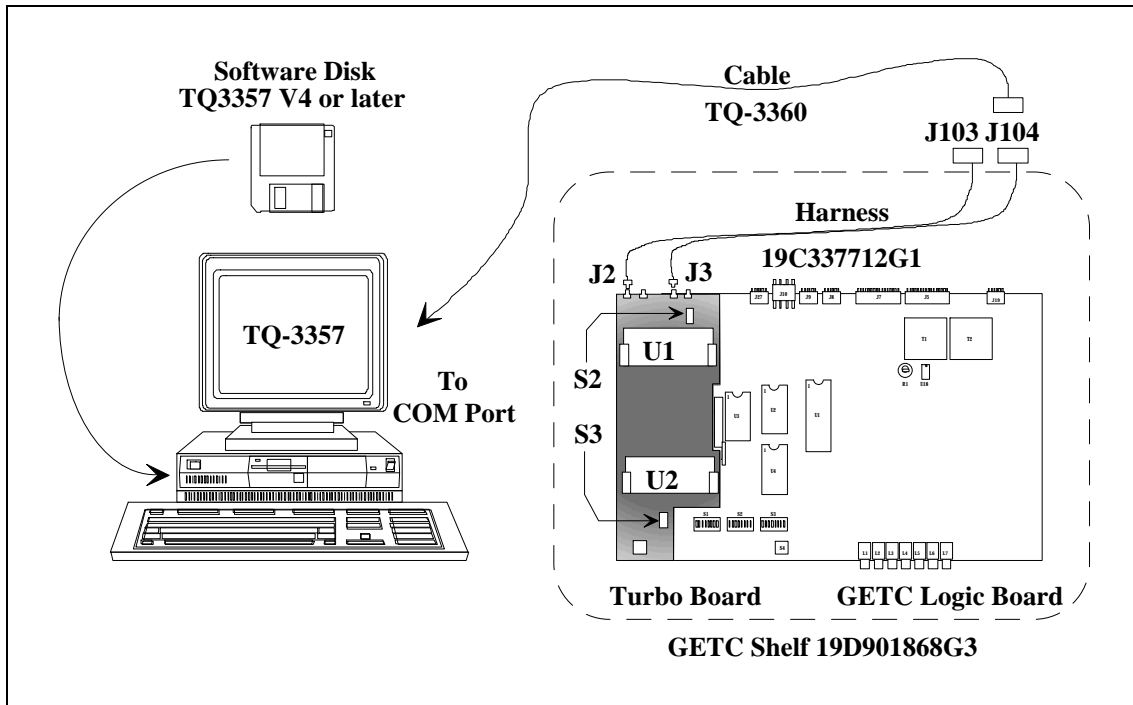

Figure 9 - System Hook-Up Using J104

Table 6 - Sample Station Personality

```

Personality: C:\GE\GTC\PERS\SCAT_PER.GTC
~~~~~
Personality Description
  These are SCAT Site and SCAT Down-
  link Personalities.
  Centralized Telephone Interconnect
  System (CTIS) Option is enabled.

Channel Allocations      11111 11111 22222 22222 333
Channel Number      1234 56789 01234 56789 01234 56789 012

Control Channel      Y... ..
Clear Voice          Y... ..
Digital Voice        .... ..
Data                 .... ..
Pager (DnLink GETC).... ..
Interconnect         .... ..
Allow DV Telephone   .... ..
Multisite Downlink   .... ..Y..
Downlink (to TSIN)  .... ..

Transmit Frequencies
Freq Band: 800 MHz
Ch # Freq (Mhz)      Ch # Freq (Mhz)      Ch # Freq (Mhz)
  1  857.0125         10 0.0000            19 0.0000
  2  0.0000           11 0.0000            20 0.0000
  3  0.0000           12 0.0000            21 0.0000
  4  0.0000           13 0.0000            22 0.0000
  5  0.0000           14 0.0000            23 0.0000
  6  0.0000           15 0.0000            24 0.0000
  7  0.0000           16 0.0000            25 0.0000
  8  0.0000           17 0.0000
  9  0.0000           18 0.0000

Site Data

Site Name   : SCATSITE1           Site ID    :      9
Date       : 08/03/94           Morse ID   :
Channel Assignment: Descending Rotating Assign: No   Indv. Call Hang : 5
Indv. Call Update : One Slot   Multisite Syst.: Yes  Group Call Hang : 5
IMC Platform      : IMC/CEC     Simulcast Syst.: No   Telephn Call Hang: 30
Wideband Pwr Sense: Disabled    CTIS(Telephone): Yes  Dig. Voice Hang : 0
Jamming Threshold : 0           Voter System  : No   Emerg. Call Hang : 5
Rem Site DV Delay : 0           SCAT         : Yes  Sys All Call Hang: 5
Max Interconnects : 1           LIDs>8192   : Yes  TX Trunked Timer : 120
Msg Trunked Timer : 300
Morse Intvl Timer: 0
    
```

Table 6 - Sample Station Personality (Continued)

CONFIRMED CALL ENABLES STATUS:						Conventional Network Interface Data	
		Clear Voice	Digital Voice				
		-----	-----				
Group Calls:	No	No			Conventional Network Logical ID : 0		
Indiv Calls:	No	No			C.N.I Group ID	C.N.I Channel Guard Tone	
Teleph Calls:	No	No					
Digital Voice Group ID						**GETC Personality Extended Options:	
Group	ID	Group	ID	Group	ID	~~~~~	
1	0	19	0	37	0	CV C-Call Timeout	0
2	0	20	0	38	0	DV C-Call Timeout	0
3	0	21	0	39	0	Wide Area DV	No
4	0	22	0	40	0	Data Mode	RF Data
5	0	23	0	41	0	Polarity Invert	None
6	0	24	0	42	0	Baud Rate	9600
7	0	25	0	43	0	Dig.Voted Inter.	Unavail
8	0	26	0	44	0	Data Protocol	Normal
9	0	27	0	45	0	Data Queuing	Disabled
10	0	28	0	46	0	Msg Trunked Data	Disabled
11	0	29	0	47	0	DataCall Hangtime	0
12	0	30	0	48	0	FS Patch Enable	Disabled
13	0	31	0	49	0	LSTX Polarity	Normal
14	0	32	0	50	0	MII/Ile 900MHz?	No
15	0	33	0	51	0	Conv. FS Enable	Disabled
16	0	34	0	52	0	MS Confirmation	0
17	0	35	0	53	0	Site Color	None
18	0	36	0	54	0	BCH Correction	Enabled

NOTE

** The contents of the *GETC Personality Extended Options* panel will display the parameters for new features when the Field Macro(s) is installed into the PC Programmer. Field Macros keep the programmer current until a fully upgraded PC Programmer which includes all features is made available. The Field Macros are supplied with the Turbo Software Media Kit and may be downloaded from Ericsson's "One1Call" retrieval system.

6. Read the existing personality from the SCAT Station GETC to the PC. If the personality does not exist, retrieve the sample SCAT Personality (shown in Table 6) from the PC. Change the personality parameters as required.

NOTE

The personality data for SCAT Downlink GETC must be the same as the Station GETC.

7. After entering the personality parameters, select the "Program Card" function to program the personality into the GETC.
8. Verify that the GETC has properly stored the personality data by selecting the "Read Unit Into File" function while in the Current Personalities Screen.
9. After completing the programming, save the revised personality to disk.
10. Reset the DIP switches and press S4 to reset the GETC.
11. Disconnect the TQ-3360 cable and verify GETC operation.

SCAT Personality

CEC/IMC Personality Configuration

At the System Manager, configure the SCAT groups as TRACKED to maximize the availability of the SCAT

channel. As a TRACKED group, the SCAT channel only receives requests from the CEC/IMC for groups that are logged into the SCAT system. The CEC/IMC bypasses the SCAT system with other multisite calls making the SCAT channel available for users within the SCAT system coverage area. Refer to LBI-38984 for System Manager programming.

Confirmed Calls

The CEC/IMC may experience excessive delays waiting for a confirmation response from a SCAT system. To prevent unnecessary delays, we recommend SCAT systems be excluded from Confirmed Calls. At the CEC/IMC Manager, set the Confirmed Call Parameter to "Y - Ignore Site for Call Confirmation." Refer to the EDACS CEC/IMC Manager (MOM PC) Operation's Manual, LBI-39024, section 3.2.9.

Wide Area Digital Option

The Wide Area Digital option is activated at the factory using a unique code for each repeater. This code is stored with the GETC Personality.

Thus changes to the personality should be made by reading the existing personality, modifying the data, and writing the modified data back to the GETC.

OPERATIONAL CHECKOUT

Verify that the GETC is operating correctly by performing the following steps:

DIP SWITCH SETTINGS

The GETC DIP Switch settings depend on the GETC's usage (Station GETC or SCAT Downlink GETC), channel, and frequency.

Through improvements in software and hardware, fewer changes in DIP switch settings are required. As a result more switch positions are being ignored and their functionality is being programmed into the GETC via the Personality Programming.

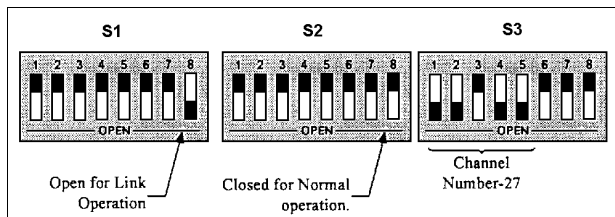

Figure 10 - Typical SCAT Station DIP Switch Settings

Set the GETC DIP switches using the following procedures:

SCAT Station GETC

Set the three GETC DIP switches (S1 - S3) for SCAT Station operation, as shown in Figure 8.

1. Set S1-1 thru S1-7 and S2-1 thru S2-4 to the repeater's operating frequency. Refer to Station GETC manual LBI-38988 or SRN1060 for DIP switch settings.

NOTE

For MASTR II/Ie (using 349A9607G5 or later) and MASTR III stations, set DIP switches S1-1 through S1-7 and S2-1 through S2-4 to the CLOSED position. Frequency is selected via the Personality programming.

2. Set S1-8 to the OPEN position.
3. Set S2-5, 6 and 8 to CLOSED and S2-7 to the OPEN position.

4. Set S3-1 to OPEN and S3-2 thru S3-5 to CLOSED. This sets the SCAT Station GETC for operation on channel number 1.
5. Set S3-6 and S3-8 to OPEN and S3-7 to CLOSED.

SCAT Downlink GETC

Set the three GETC DIP switches (S1 - S3) for SCAT Downlink operation. Refer to the Link GETC Configuration manual, LBI-38896, and SRN1061 for instructions.

CLEAR VOICE CHECKOUT

The following tests allow you to confirm the SCAT Station GETC operation when the GETC operates as a Control Channel GETC and when making Clear Voice (CV) calls

Locally Initiated Calls

This procedure assumes that the test radios being used have their personalities programmed to enable SCAT, set to the SCAT group frequency, and operating in Clear Voice mode.

1. Apply power to the station (or reset the GETCs). The station should default to the Control Channel mode.
2. Verify the SCAT and SCAT Downlink GETC LEDs when the station is in the Control Channel mode (see Table 7).
 - SCAT Station GETC - L1, L6, and L7 turn ON.

Table 7 - SCAT Station GETC, CC Mode

LED Indicators	L1	L2	L3	L4	L5	L6	L7
Control Channel (Idle Mode)	●	○	○	○	○	●	●

Legend: ○ = OFF ● = ON * = FLASHING

3. Set test radios 1 and 2 to group 1.
4. Initiate a call from radio 1 to radio 2.
5. Verify that the SCAT Station GETC switches from the Control Channel mode to the Working Channel mode as shown in Table 8 (LED L7 goes OFF).

Table 8 - LED Indications, Clear Voice Local Call

LED Indicators	L1	L2	L3	L4	L5	L6	L7
CV Working Channel	●	○	○	○	○	●	○

Legend: ○ = OFF ● = ON * = FLASHING

- Verify that voice can be heard on both radios and that the ID of the transmitting radio is displayed on the receive radio.
- Unkey the radio and verify that the station returns to the Control Channel mode.

Multisite Initiated Calls

- Initiate a multisite call or a console call to a radio assigned to the SCAT station.
- When the call is received, verify that SCAT Station GETC LED L7 turns OFF and L2 turns ON as shown in Table 9.

Table 9 - LED Indications, Clear Voice Multisite Call

LED Indicators	L1	L2	L3	L4	L5	L6	L7
CV Working Channel (Multisite initiated call.)	●	●	○	○	○	●	○

Legend: ○ = OFF ● = ON * = FLASHING

- When the call is finished, verify that the LEDs change state indicating the station has returned to the Control Channel mode.

DIGITAL VOICE CHECKOUT

The following tests allow you to confirm the SCAT Station GETC operation when making Digital Voice (DV) calls

Locally Initiated Calls

- Setup the radios for Digital Voice operation.

NOTE

The SCAT Station GETC must have the Wide Area Digital option enabled to perform this test. Contact your EGE Sales Representative and ask for option SXS7A. If your SCAT Station GETC does not have a Rockwell Modem, also order option SXMD1D.

- Initiate a call from radio 1 to radio 2 using the Digital Voice mode.
- When the call is received, verify that SCAT Station GETC LEDs L1, L6, and L7 turn ON (see Table 10).

Table 10 - LED Indications, Digital Voice Local Call

LED Indicators	L1	L2	L3	L4	L5	L6	L7
DV Working Channel (Locally initiated call.)	●	○	○	○	○	●	●

Legend: ○ = OFF ● = ON * = FLASHING

- When the call is finished, verify that the LEDs change state indicating the station has returned to the Control Channel mode.

Multisite Initiated Calls

- Initiate a multisite or console DV call to a radio assigned to the SCAT station.
- When the call is received, verify that SCAT Station GETC LED's L1, L2, L6, and L7 turn ON as shown in Table 11.

Table 11 - LED Indications, Digital Voice Multisite Call

LED Indicators	L1	L2	L3	L4	L5	L6	L7
DV Working Channel (Multisite initiated call.)	●	●	○	○	○	●	●

Legend: ○ = OFF ● = ON * = FLASHING

- When the call is finished, verify that the LEDs change state indicating the station has returned to the Control Channel mode.

LED Indicators

Table 12 is a summary of the operating modes and the associated LED indications.

Table 12 - LED Indications, Summary

LED Indicators	L1	L2	L3	L4	L5	L6	L7
SCAT STATION GETC							
Control Channel	●	○	○	○	○	●	●
CV Working Channel. Locally initiated call.	●	○	○	○	○	●	○
CV Working Channel. Multisite initiated call.	●	●	○	○	○	●	○
DV Working Channel. Locally initiated call.	●	○	○	○	○	●	●
DV Working Channel Multisite initiated call.	●	●	○	○	○	●	●
Downlink GETC							
Downlink.	●	●	○	○	*	*	○

Legend: ○ = OFF ● = ON * = FLASHING

TROUBLESHOOTING

The hardware used in the GETC is extremely reliable, making component failure the unlikely cause of most problems. The most common causes of problems are programming errors and interface connections.

Use the following guidelines when troubleshooting a GETC on site:

1. Verify proper operation of front panel LEDs.
2. Verify that all cables are properly connected and secure.
3. Verify the GETC's personality is properly programmed for the specific application. Refer to TQ-3357, PC Programmer and SRN1061.
4. In Downlink GETCs, verify the Turbo Board is properly configured if applicable. Refer to LBI-38822, TQ-3357, and SRN 1061.
5. If you suspect that the GETC has failed, replace the GETC with a known good unit properly configured for this application.

DOWNLINK ACTIVITY LOGGER

A diagnostic feature introduced with the 344A4895G4 software is the Downlink Activity Logger. This feature allows the Downlink GETC to log and save information about communication activity between the Downlink and Uplink GETC. In General, the information supplied by the Downlink Activity Logger is EDACS specific and in some cases may need technical assistance for interpretation. For detailed instructions on using the Channel Activity Logger, refer to SRN1061 and TQ 3357 V4.03 (or later).

IN CASE OF DIFFICULTY

If you are unable to resolve a problem to your satisfaction, then contact the Ericsson Technical Assistance Center (TAC) at 1-800-528-7711 (outside USA, 804-528-7711).

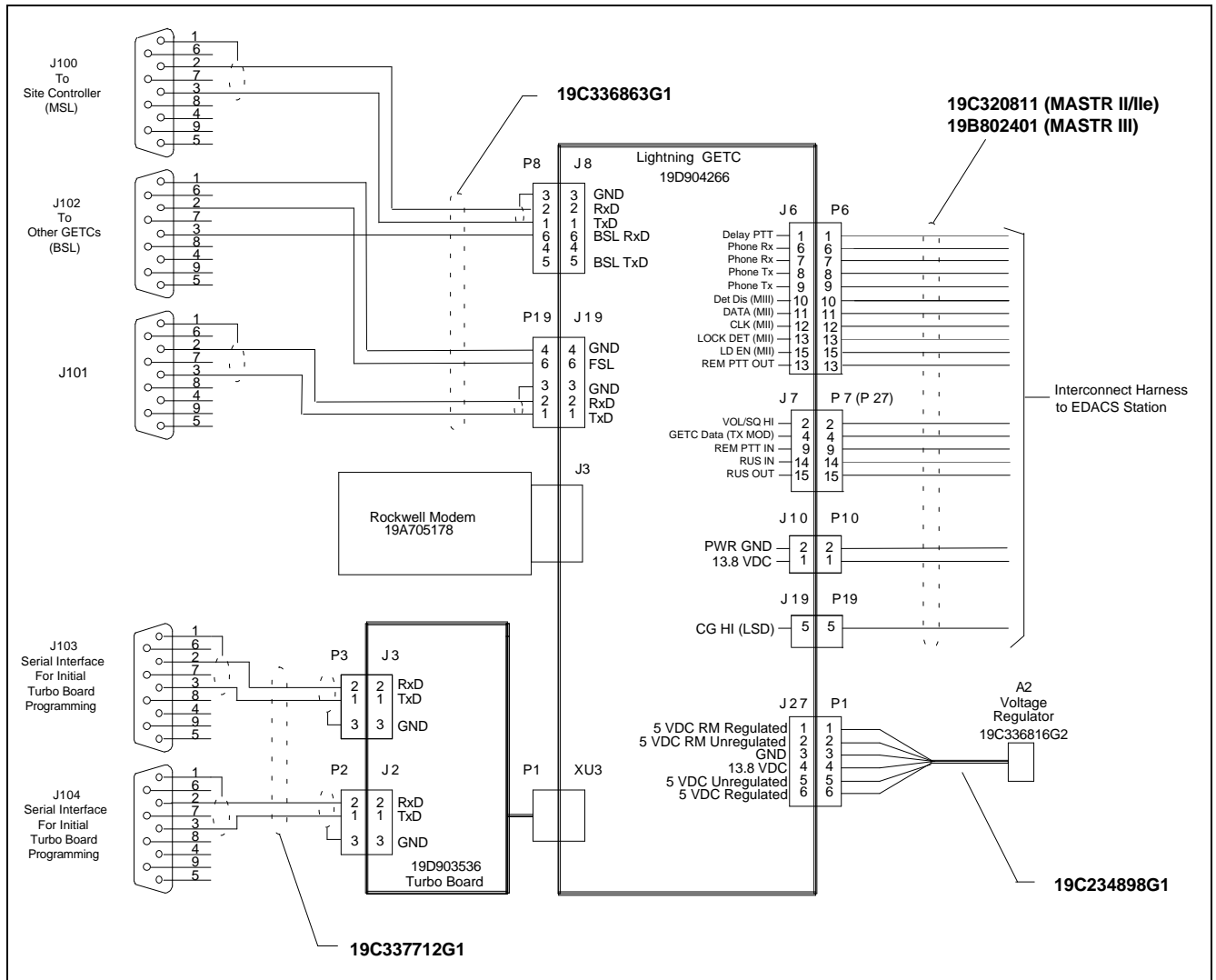

STATION GETC SHELF
INTERCONNECT DIAGRAM

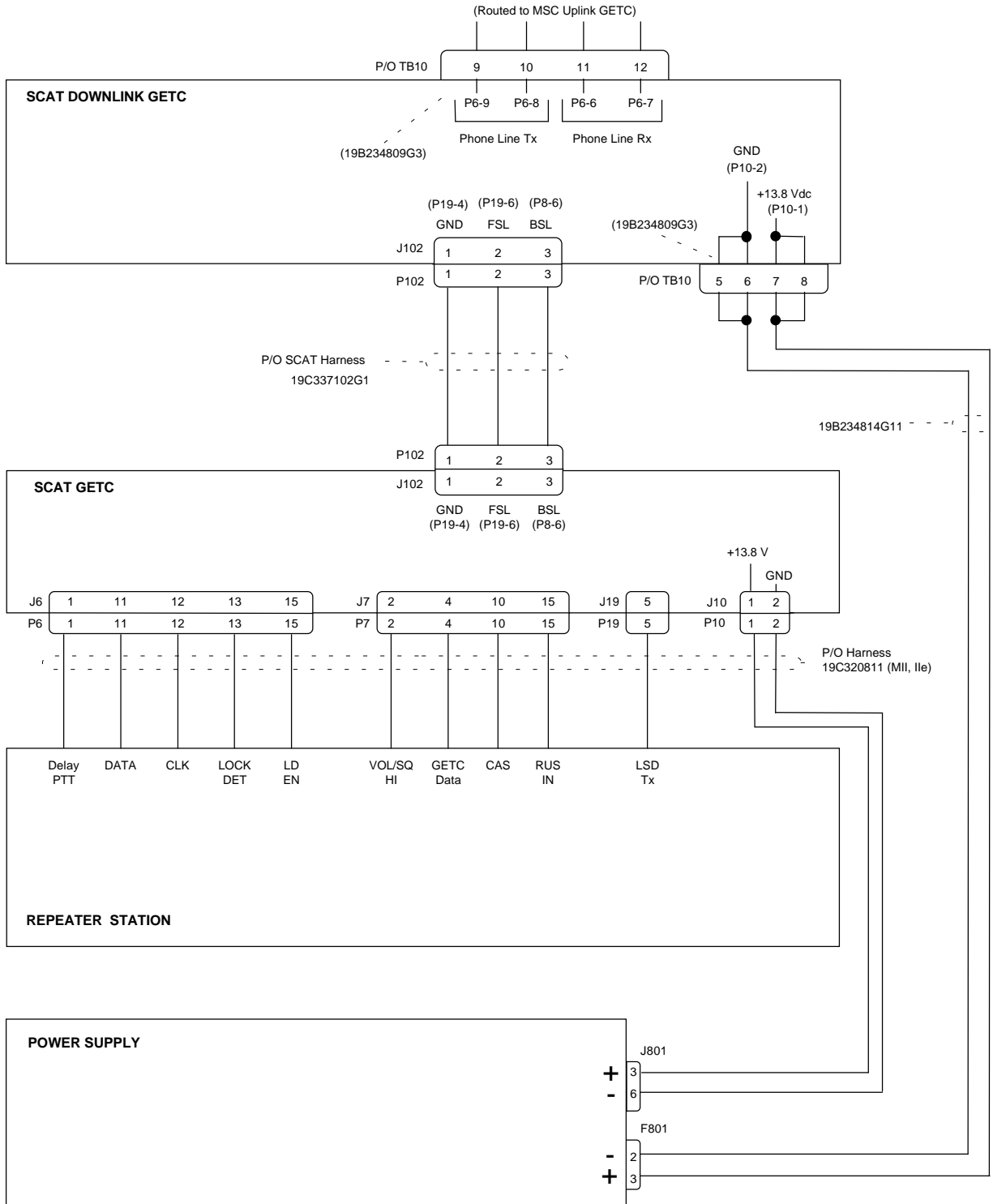

MASTR II (IIe) EDACS NETWORK SCAT INTERCONNECTION DIAGRAM

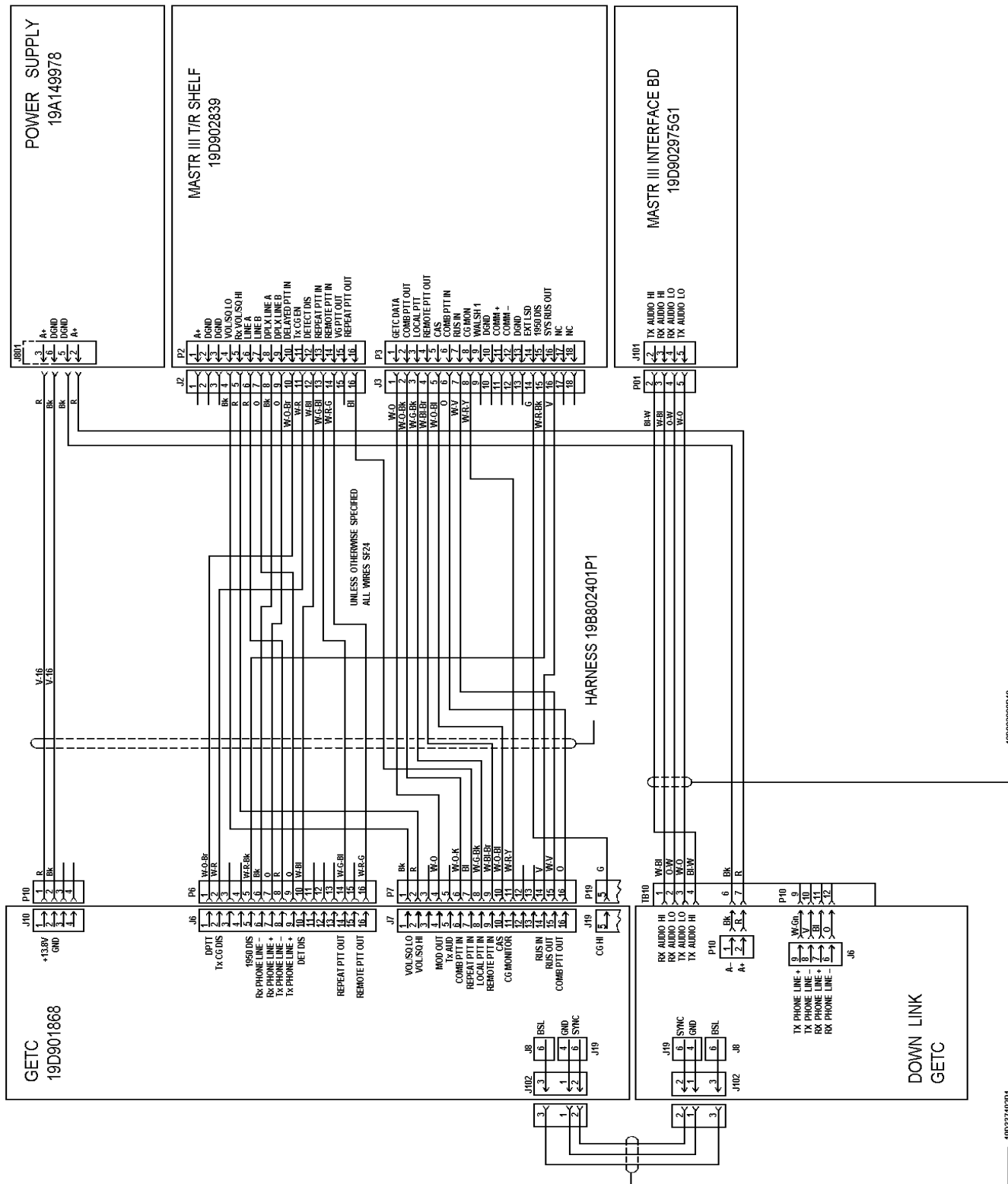

**MASTR III EDACS NETWORK SCAT
INTERCONNECTION DIAGRAM**

(188D5683, SH.1, REV.)

**GETC CABLE
19C336863G1**

SYMBOL	PART NUMBER	DESCRIPTION
		----- JACKS -----
J100 thru J102	19B209727P18	Connector: 9 contacts; sim to AMP 205203-1.
		----- PLUGS -----
P8	19A700041P32	Shell: 6-Position; sim to Molex 22-01-2065.
P19	19A700041P32	Shell: 6-Position; sim to Molex 22-01-2065.
		----- MISCELLANEOUS -----
2	19B209727P11	Contact, electrical: sim to AMP 1-66504-0.
3	19A704779P26	Contacts: 22-30 AWG; sim to Molex 08-55-0101, Qty of 10.
4	19J706152P5	Retainer strap: sim to Panduit Corp. SST-1.
6	19A149502P3	Sleeving, spiral.
13	19B209727P9	Machine Screw.

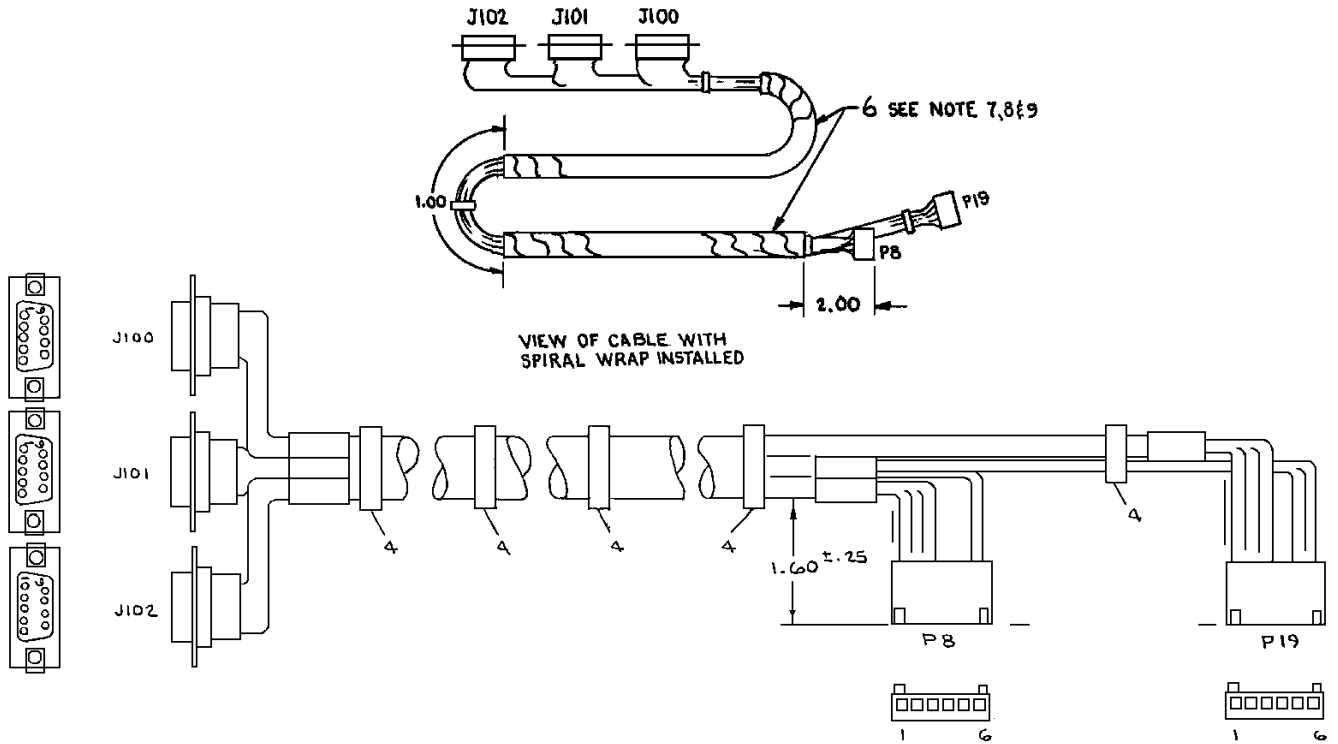
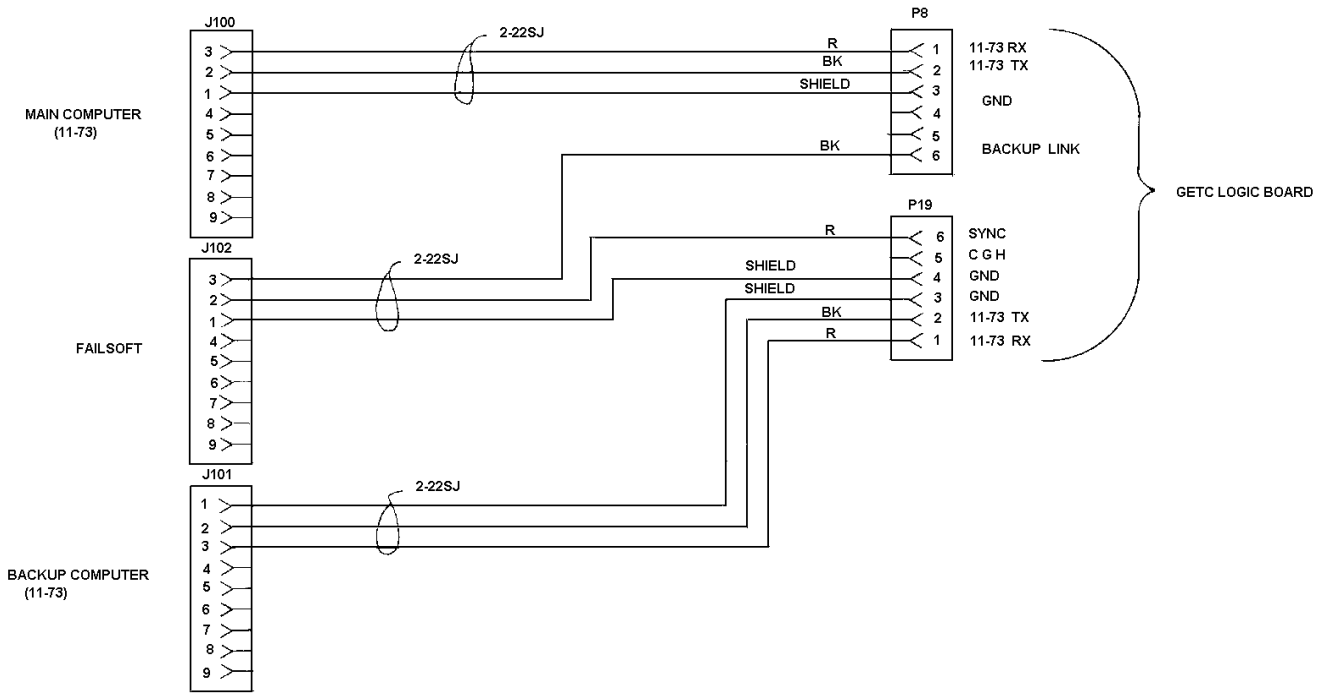

GETC CABLE

19C336863G1

(19C336863, Sh. 1, Rev. 4; 19C336866, Sh. 1, Rev. 0)

CONNECTION DIAG

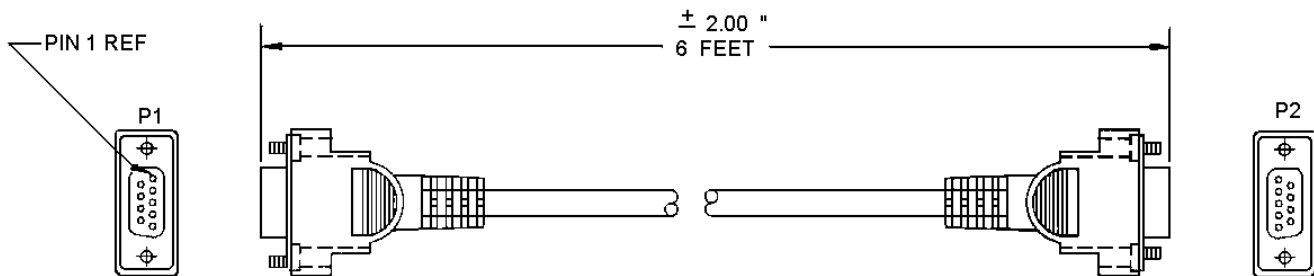
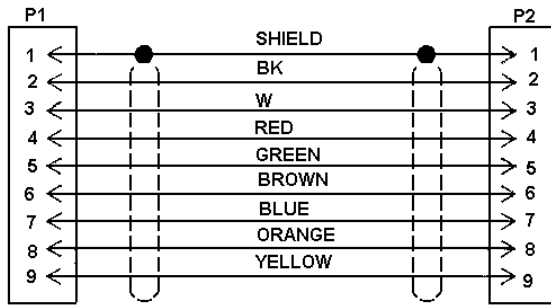

SCAT INTERCONNECT CABLE

19C337102G1

(19C337102, Sh. 1, Rev. 0)

This page intentionally left blank

