

MAINTENANCE MANUAL
ORION™
SYSTEM CONTROL

CONTROL UNIT 334A4581P1/CMD-556BL (SCAN MODEL LOCAL TYPE)
CONTROL UNIT 344A4581P2/CMD-556BR (SCAN MODEL REMOTE TYPE)
CONTROL UNIT 344A4581P3/CMD-556ML (SYSTEM MODEL LOCAL TYPE)
CONTROL UNIT 344A4581P4/CMD-556MR (SYSTEM MODEL REMOTE TYPE)

PANEL CONTROL CMC-638 (Used in P1 through P4)
SWITCH CIRCUIT CDF-368B (Used in P1, P2)
SWITCH CIRCUIT CDF-368M (Used in P3, P4)
REMOTE INTERFACE ADAPTOR NQZ-4882 (Used in P2, P4)

TABLE OF CONTENTS

DESCRIPTION	Page
DESCRIPTION	1
CIRCUIT ANALYSIS	1
IC DATA	2
PARTS LIST	
CONTROL UNITS:	
344A4581P1	6
344A4581P2	6
344A4581P3	6
344A4581P4	6
Panel Control	6
Switch Circuit	7
Remote Interface Adapter	7
Production Changes	7
OUTLINE DIAGRAMS:	
PANEL CONTROL	8
SWITCH CIRCUIT	9
INTERCONNECTION DIAGRAMS	
CONTROL UNIT (LOCAL TYPE)	11
CONTROL UNIT (REMOTE TYPE)	12
SCHEMATIC DIAGRAMS	
PANEL CONTROL	13
SWITCH CIRCUIT (BASIC MODEL)	14
SWITCH CIRCUIT (MID MODEL)	15
REMOTE INTERFACE ADAPTER	Back Cover

SCHEMATIC DIAGRAM

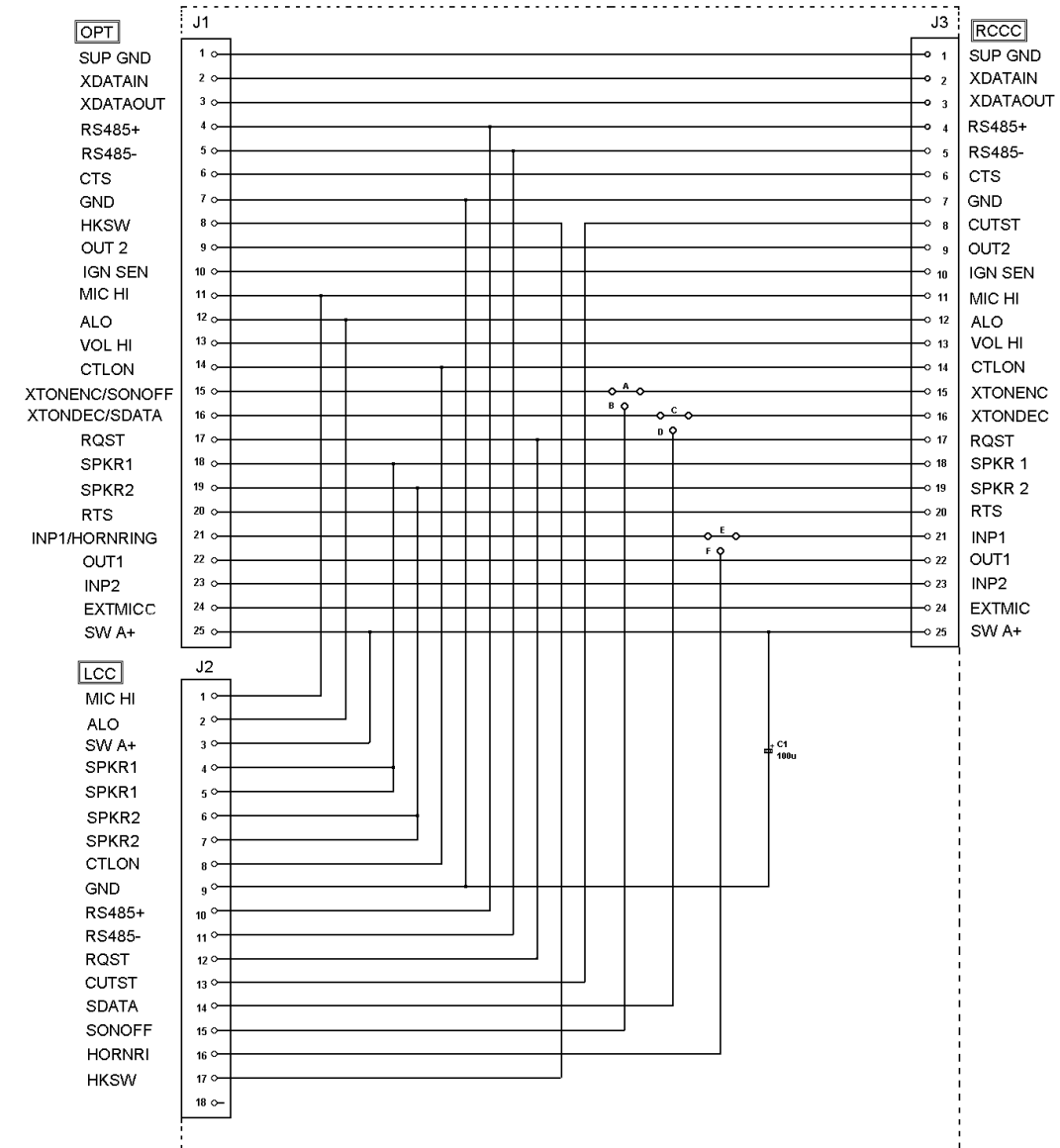

REMOTE INTERFACE ADAPTER
(DD00-NQ2-4882)

Ericsson Inc.
Private Radio Systems
Mountain View Road
Lynchburg, Virginia 24502
1-800-528-7711 (Outside USA, 804-528-7711)

DESCRIPTION

The **ORION™** mobile radio has two control units available, the **SCAN** model and the **SYSTEM** model (see Figures 1 and 2). Also refer to Assemblies Maintenance Manual **LBI-38909**. Each control unit consists of:

- Switch Circuit A1
- Panel Control A2
- Interconnecting Circuit PC1
- Interconnecting Circuit PC2

The Panel Control and Switch Circuit boards are housed in the Control Unit Assembly of the ORION mobile radio. The Switch Board contains the control switches and indicators used to communicate information between the radio and the operator. The Panel Control board interfaces and process signals between the Switch board and the rest of the radio.

The electrical and mechanical connections between the internal circuit boards of the two control units are identical (refer to the Interconnection Diagrams DD00-CMD-556ML for the locally connected control unit and DD00-CMD-556MR for the remote connected control unit.)

The control unit for a locally connected control unit (front mount installation) connects directly to the radio circuit boards through the **Local Control Connector (LCC)**. This connection uses interconnect board PC2 (B19/6PCLD00321).

The control unit for a remote connected control unit (trunk mount installation) also uses PC2 but in addition incorporates a **Remote Interface Adaptor (RIA)**. The **RIA** (NQZ-4882) con-

nects to the back of the control unit on the PC2 and provides the interface for accessories through the **OPTion (OPT)** connector and the **Remote Control Connector (RCC)** connector.

Switch Circuit A1 (CDF-368B for the **SCAN** model and CDF-368M for the **SYSTEM** model) plugs in to Panel Control A2 (CMC-638). These Switch Circuits provide a microphone connector and all push switch combinations for **SCAN** and **SYSTEM** control units.

The Rotary Selector switch (S1) and Power/Volume control (S2) connects to the Panel Control circuit (A1) through circuit board connector PC1 (B19//6PCLD00307).

CIRCUIT ANALYSIS

PANEL CONTROL BOARD

The Panel Control Board interfaces between the Switch Board, the Logic Board and the microphone. The board contains microcontroller IC203, EEPROM IC202, Vacuum Fluorescent Display (VFD), VFD driver IC209, Voltage regulators IC207 and IC208, power reset IC206, voltage level converter, light sensor, interface circuitry and back lighting control.

Power enters the board through connector J203 from the Logic Board. Switched A+ (SW A+) is applied to two voltage regulators IC207 and IC208. Regulator IC207 provides +5 Vdc to power the logic circuitry, and IC208 provides +9 Vdc for the backlight LED indicators and voltage converter (refer to Figure 3). Power-on reset is provided by the 5-volt regulator **RESET** line and is applied to the **RESET** input of microcontroller

IC203 on Pin 1. Microphone connections are made to the board through connector J202. No audio processing is performed on the Panel Control Board and the microphone lines **MIC HI** and **ALO** are passed to the Logic Board through connector J203.

Signal lines from the operating control switches, **OPT**, **MENU**, etc., on the Switch Board enter the Panel Control Board at J202. These active low lines are diode protected by diodes CD204 through CD216 and pulled up to 5 volts by resistors R233 through R240. All lines connect directly to microcontroller IC203.

Backlight levels of the operating controls are set by current transistor switches TR202 and TR203. These switches complete the path from +9 volts, through the backlight diodes on the Switch Board and back to ground. Return current from the backlight LED's flows into the Panel Control Board at J202, Pin 9 (**BKLT**). and is tied to the current switches through resistors R220 and R221. The **LGHT-PWR1** and **LGHT-PWR2** lines from the microcontroller IC203, Pins 57 and 58 are connected to switch drivers TR204 and TR205. Depending on the levels of **LGHT-PWR1** and **LGHT-PWR2**, the two current switches are turned on or off in different combinations, effectively placing different values of resistor (R220 and R221) in the return path. Four different backlight levels are possible.

The **RS485+** and **RS485-** lines are connected to the **UART** of the microcontroller through RS485 line driver/receiver. The **RQST** line is bi-directional and provides an indication that data is present on the **RS485** serial data bus. As an output, the line is pulled LOW to indicate that the Control Unit (CU) wishes to transmit a data message to another ter-

minal. As an input a LOW state indicates a data message is to be received by the control unit.

The microcontroller clock frequency is set by crystal X201 which is connected to IC203, Pins 2 and 3.

The EEPROM has a storage capacity of 512 x 8 bits.

The VFD is a sixteen digit, dot matrix display. Serial data to be displayed by the VFD comes from the microcontroller bus is applied to IC209, Pin 16. The clock pulse and CS signal are applied to the VFD driver at Pins 15 (**SCK**) and 14 (**CS**).

SWITCH CIRCUIT

The Switch Circuit Board contains the keypad function LED's, bottom backlight LED's and control switches. This board interfaces to the Panel Control Board through connector J201.

Back lighting is provided for the control switches **OPT**, **MENU**, etc. There are four backlight levels (including off) that are available. These levels are set on the Panel Control Board through the use of two current switches. The amount of current flowing from +9 V through the backlight diodes and returning to ground (**BKLT**) is controlled by the settings of the current switches on the Panel Control Board.

The operating control switches on the front panel are all tied to a bus through connector J101 to the Panel Control Board. The switch states are read by the microcontroller on the Panel Control Board.

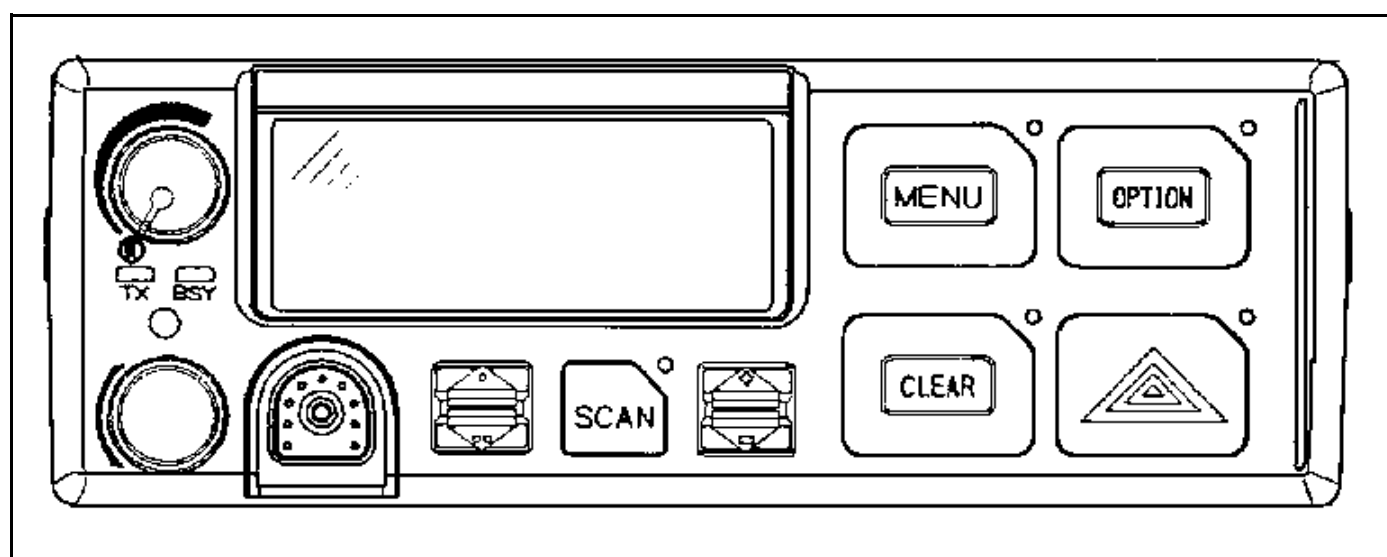

Figure 1 - SCAN Model Control Unit

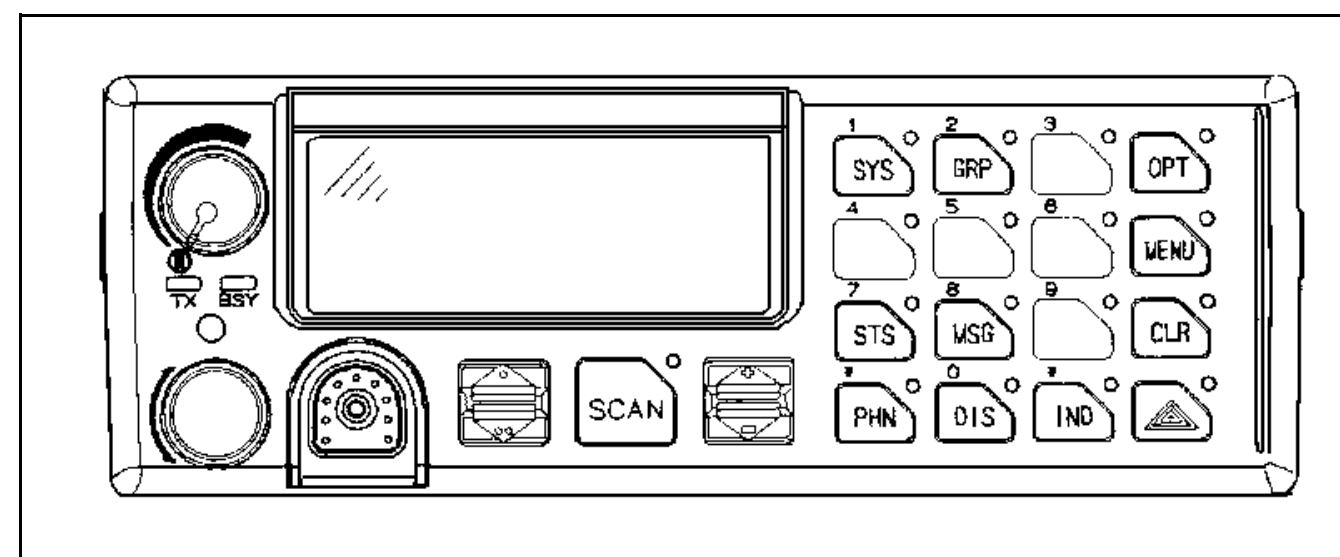

Figure 2 - SYSTEM Control Unit

A shift register is used to receive the serial data signal and provide a parallel output used to drive the keypad function LED's.

REMOTE INTERFACE ADAPTOR

The Remote Interface Adaptor (RIA) Board interfaces between the Panel Control Board, the option connector and the Remote Control Cable through the RCCC connector. The RIA board contains the LCC, ORCC and RCCC connectors. No active circuitry is on the RIA board.

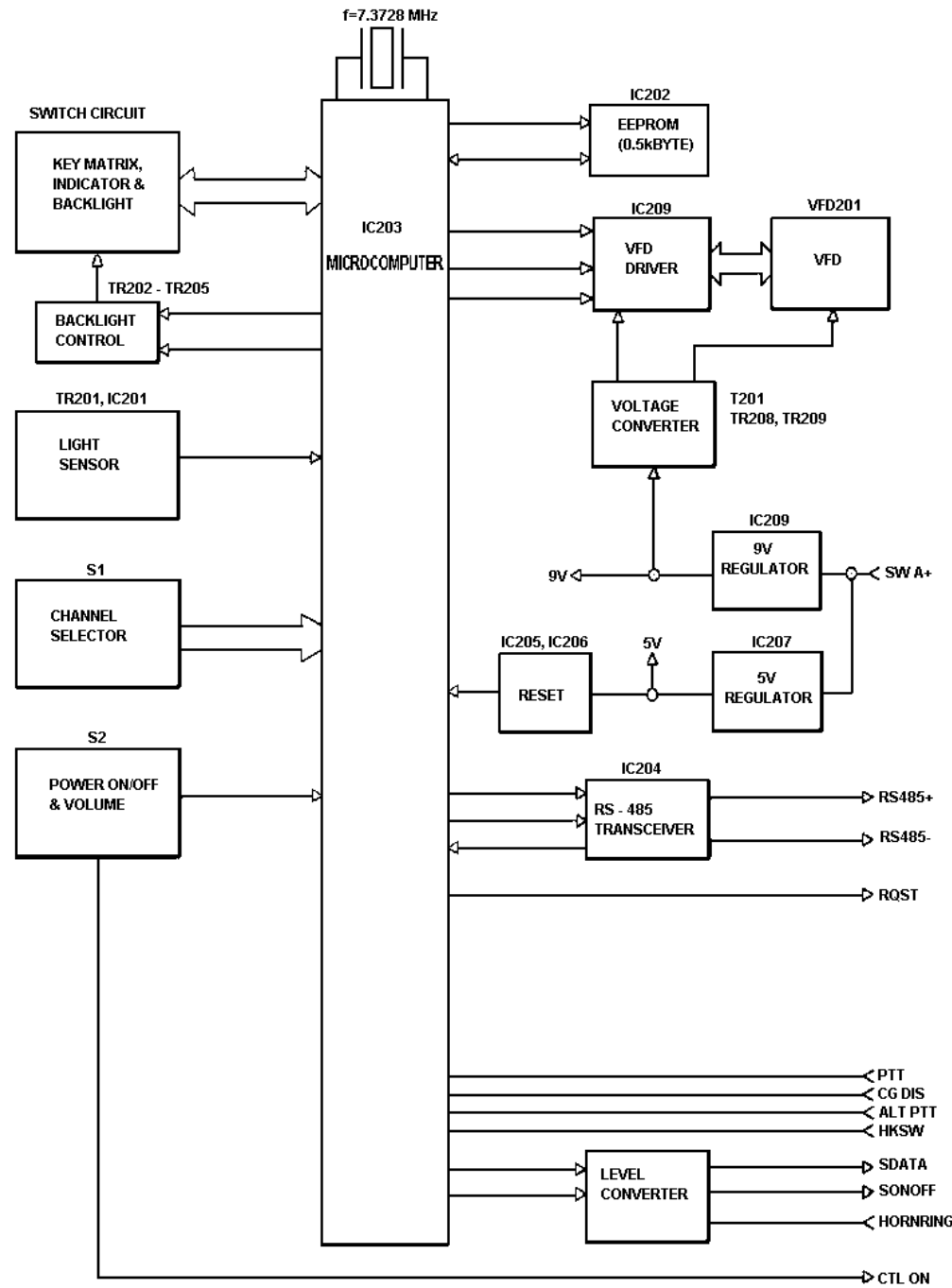
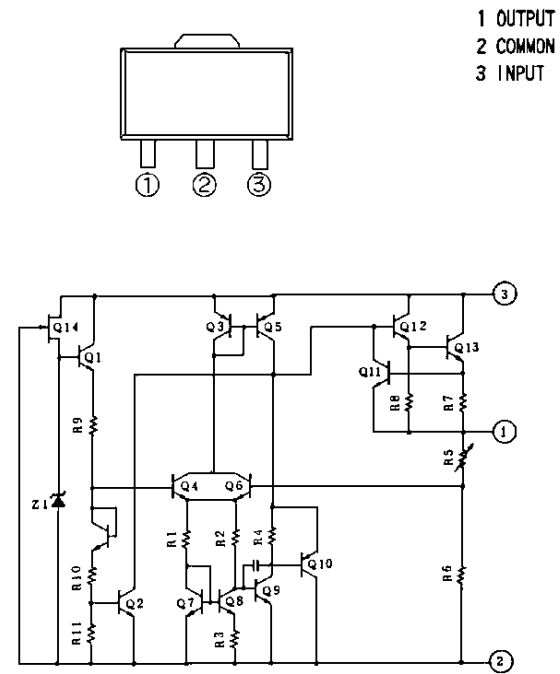
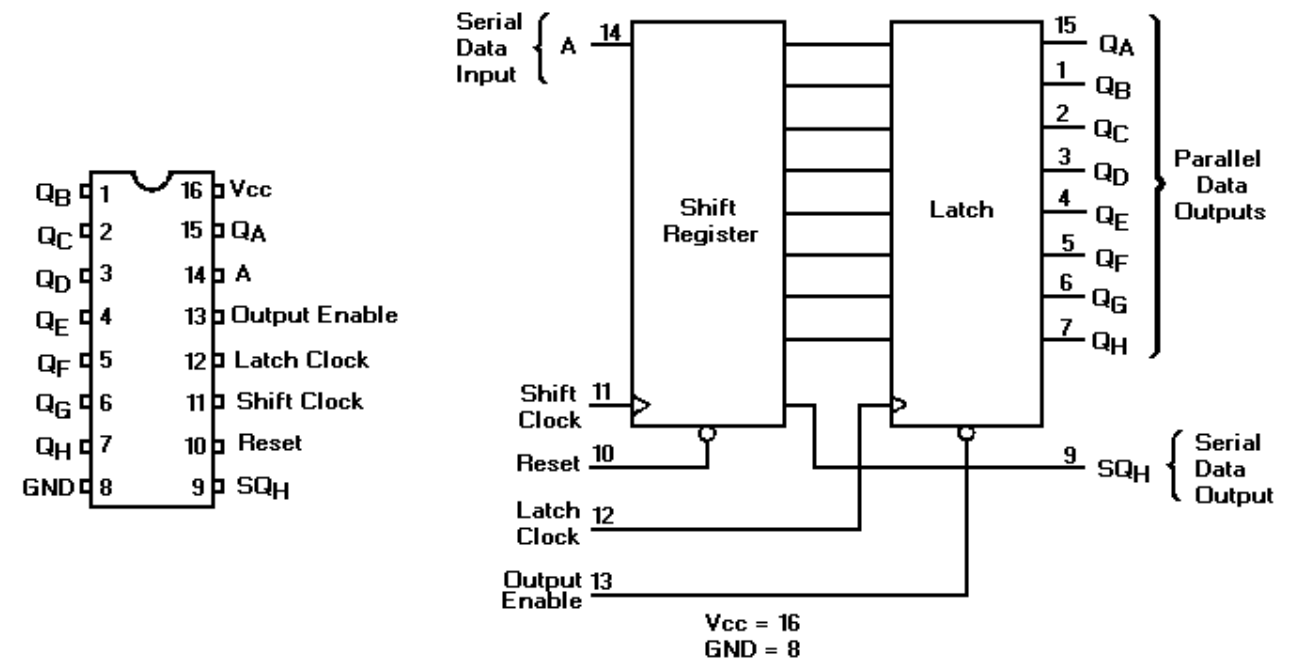

Figure 3 - Block Diagram

LINEAR: POSITIVE VOLTAGE REGULATOR IC101



DIGITAL, 8 BIT SHIFT REGISTER IC102



RS-485 TRANSCEIVER IC204

DIGITAL: BILATERAL SWITCH IC205

LINEAR: POSITIVE VOLTAGE REGULATOR IC207

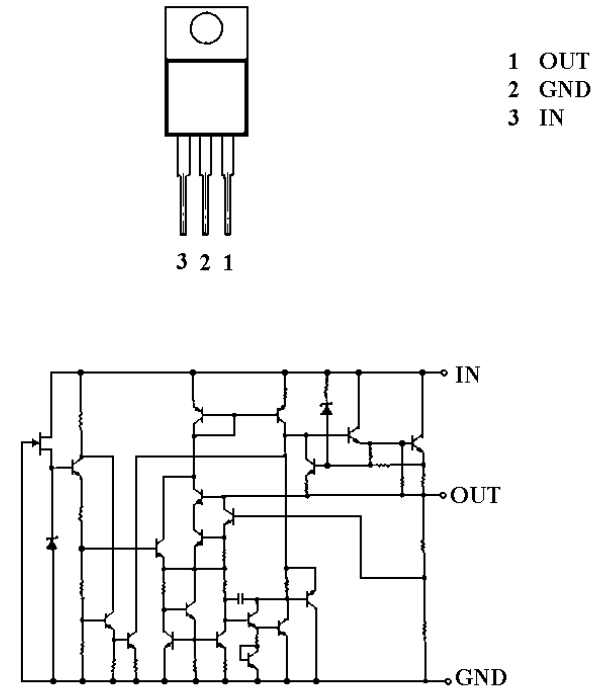
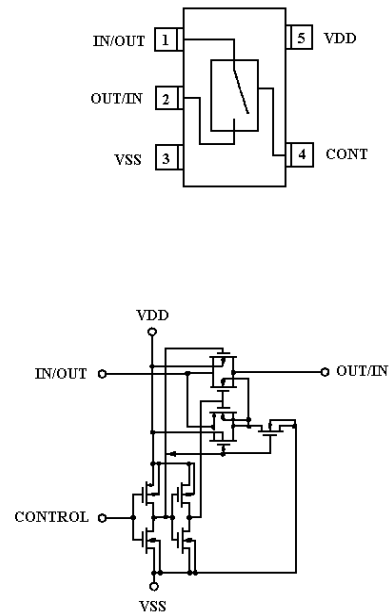
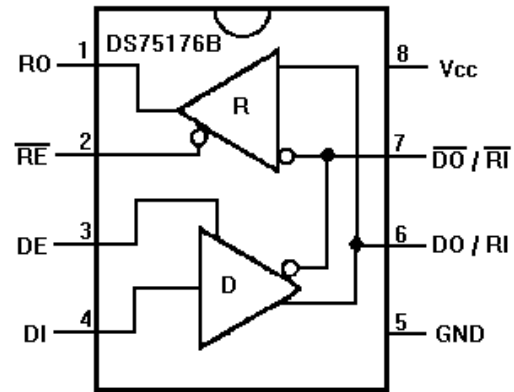

LINEAR; SYSTEM RESET IC206

LINEAR: POSITIVE VOLTAGE REGULATOR IC208

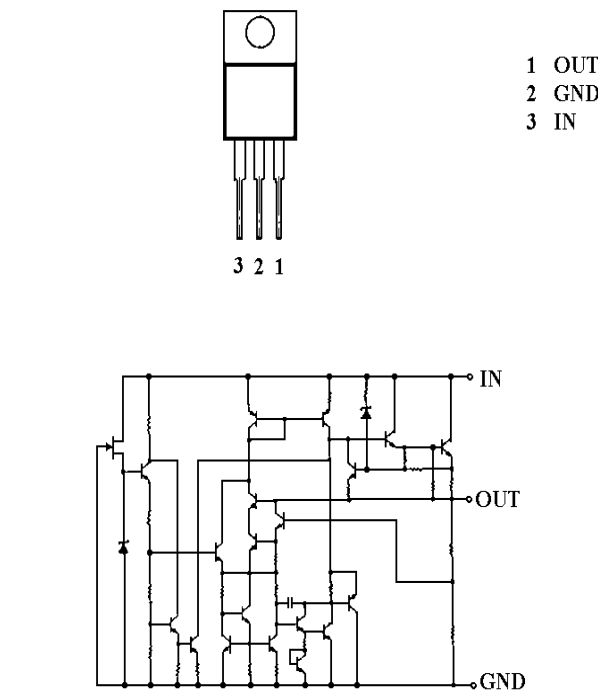
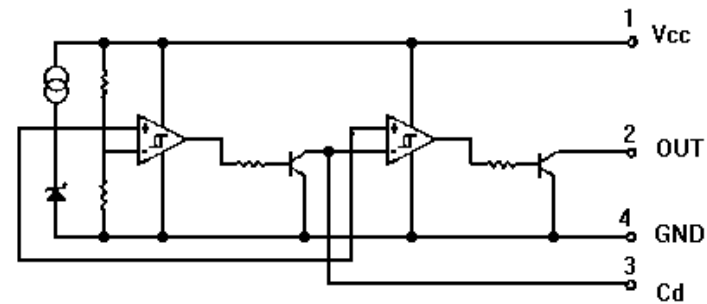
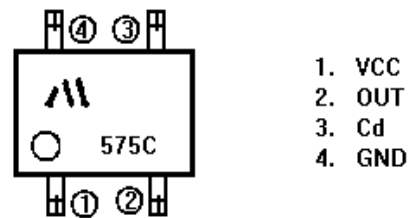

DIGITAL: VFD CONTROLLER IC209

LINEAR: PHOTOCOUPLER IC210, IC211

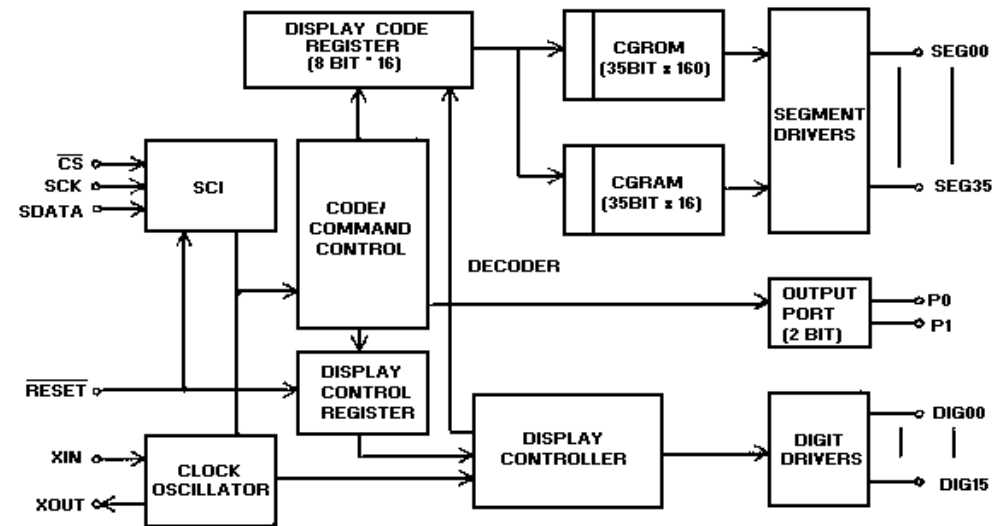
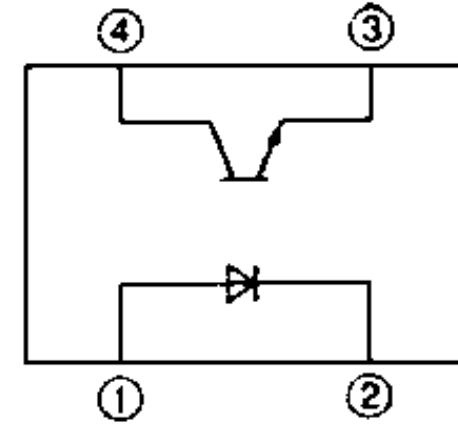
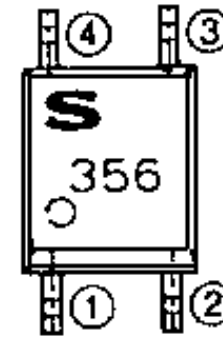
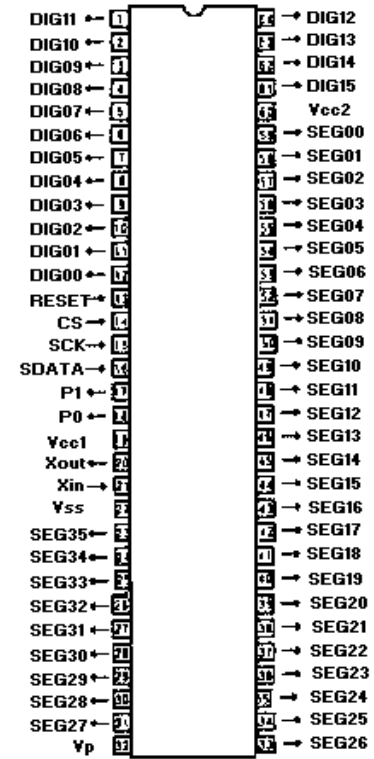

CONTROL UNIT
344A458IP1/CMD-556BL
(SCAN MODEL LOCAL TYPE)

SYMBOL	PART NO.	DESCRIPTION
A1	NOTE: Parts listed are for reference only. Refer to Service Section for serviceable parts.	SWITCH CIRCUIT CDF-368B.
A2		PANEL CONTROL CMC-638.
PC1		FPC.
PC2		FPC.
S1		ROTARY SWITCH KER16-28.
S2		VOLUME V12M4-5(PVB)S(12V2A)15F.

CONTROL UNIT
344A458IP2/CMD-556BR
(SCAN MODEL REMOTE TYPE)

SYMBOL	PART NO.	DESCRIPTION
A1	NOTE: Parts listed are for reference only. Refer to Service Section for serviceable parts.	SWITCH CIRCUIT CDF-368B.
A2		PANEL CONTROL CMC-638.
A3		RIA NQZ-4882
PC1		FPC.
PC2		FPC.
S1		ROTARY SWITCH KER16-28.
S2	VOLUME V12M4-5(PVB)S(12V2A)15F.	

CONTROL UNIT
344A458IP3/CMD-556ML
(SYSTEM MODEL LOCAL TYPE)

SYMBOL	PART NO.	DESCRIPTION
A1		SWITCH CIRCUIT CDF-368M.
A2		PANEL CONTROL CMC-638.
PC1		FPC.
PC2		FPC.
S1		ROTARY SWITCH KER16-28.
S2		VOLUME V12M4-5(PVB)S(12V2A)15F.

CONTROL UNIT
344A458IP4/CMD-556MR
(SYSTEM MODEL REMOTE TYPE)

SYMBOL	PART NO.	DESCRIPTION
A1		SWITCH CIRCUIT CDF-368M.
A2		PANEL CONTROL CMC-638.
A3		RIA NQZ-4882
PC1		FPC.
PC2		FPC.
S1		ROTARY SWITCH KER16-28.
S2	VOLUME V12M4-5(PVB)S(12V2A)15F.	

PANEL CONTROL
CMC-638
(Used in P1, P2, P3, P4)

SYMBOL	PART NO.	DESCRIPTION
		----- CAPACITORS -----
C201 Thru C226		Ceramic: 100 pF ±5% 50 VDCW temp coef +350/-1000 PPM.
C227 And C228		Ceramic: 27 pF ±5% 50 VDCW temp coef +350/-1000 PPM.
C229 And C230		Ceramic: 0.1 µF +80/-20%, 25 VDCW.
C231 And C232		Polypropylene: 10 µF ±20% 16 VDCW.
C233		Ceramic: 1000 pF ±10% 50 VDCW temp coef 15%.
C234		Ceramic: 100 pF ±5% 50 VDCW temp coef +350/-1000 PPM.
C235		Ceramic: 0.1 µF +80/-20%, 25 VDCW.
C236		Electrolytic: 1 µF ±20% 16V.
C237		Polypropylene: 10 µF ±20% 16 VDCW.
C238		Ceramic: 0.1 µF +80/-20%, 25 VDCW.
C239		Polypropylene: 10 µF20% 16 VDCW.
C240 And C241		Ceramic: 0.1 µF +80/-20%, 25 VDCW.
C242		Polypropylene: 10 µF ±20% 16 VDCW.
C243 Thru C247		Ceramic: 100 pF ±5% 50 VDCW temp coef +350/-1000 PPM.
C248		Ceramic: 0.01 µF ±10% 50 VDCW, temp coef ±15%.
C249		Ceramic: 100 pF ±5% 50 VDCW temp coef +350/-1000 PPM.
C250		Electrolytic: 1 µF ±20% 16V.
C251		Polypropylene: 10 µF20% 50 VDCW.
C252		Tantalum: 47 µF ±20% 16 VDCW.
C253		Tantalum: 3.3 µF ±20% 16 VDCW.
C254		Ceramic: 1000 pF ±10% 50 VDCW temp coef ±15%.
C255		Ceramic: 0.01 µF ±10% 50 VDCW, temp coef ±15%.
C256		Ceramic: 0.1 µF +80/-20%, 25 VDCW.
C257		Tantalum: 22 µF ±20% 16 VDCW.
		----- DIODES -----
CD201		Optoelectronic: orange sim to TOSHIBA TLO205.
CD202		Optoelectronic: red sim to TOSHIBA TLR205.
CD203		Silicon fast recovery (2 diodes in cathode common); sim to TOSHIBA ISS184.
CD204 Thru CD219		Silicon fast recovery (2 diodes in series); sim to TOSHIBA 1SS226.
CD220		Zener: 5.1 V; sim to ROHM RLZ5.1B.
CD221		Silicon Epitaxial Planar Diode: sim to ROHM RLS92.
CD222		Silicon Epitaxial Planar Diode: sim to ROHM RLS245.
CD223		Zener: 5.1 V; sim to ROHM RLZ5.1B.
CD226		Silicon fast recovery (2 diodes in series); sim to TOSHIBA 1SS226.
		----- INTEGRATED CIRCUITS -----
IC201		Linear, Dual OP AMP; sim to NEW JRC NJM3404M.
IC202		Digital: EEPROM; sim to ATMEL AT24C04N-10SI.
IC203		Digital: Microcomputer; sim to HITACHI HD643308RC28F.
IC204		RS-485 Transceiver: sim to NS DS75176BM.
IC205		Digital: Bilateral; sim to MOTOROLA SC14S66F.
IC206		Linear: System Reset IC; sim to MITSUMI PST575CMT.

SYMBOL	PART NO.	DESCRIPTION
IC207		Linear: Positive Voltage Regulator; sim to NEW JRC NJM7805A.
IC208		Linear: Positive Voltage Regulator; sim to NEW JRC NJM7809A.
IC209		Digital: VFD Controller; sim to MITSUBISI M66004FP.
IC210 And IC211		Linear: Photocoupler; sim to SHARP PC356T.
		----- CONNECTORS -----
J201		Connector: 12 pins.
J202		Connector: 30 pins.
J203		Connector: 18 pins.
		----- COILS -----
L201 And L202		Choke Coil: 10 µH .
		----- RESISTORS -----
R201 And R202		Metal film: 470 ohms ±5%, 150 VDCW 1/10W.
R203		Metal film: 100 ohms ±5%, 150 VDCW 1/2W.
R204 And R205		Metal film: 1K ohms ±5%, 150 VDCW 1/4W.
R206		Metal film: 560K ohms ±5%, 150 VDCW 1/4W.
R207 Thru R219		Metal film: 100 ohms ±5%, 150 VDCW 1/2W.
R220		Metal film: 47 ohms ±5%, 200 VDCW 1/2W.
R221		Metal film: 100 ohms ±5%, 200 VDCW 1/4W.
R222		Metal film: 4.7K ohms ±5%, 150 VDCW 1/10W.
R223 Thru R242		Metal film: 10K ohms ±5%, 150 VDCW 1/10W.
R243		Metal film: 4.7k ohms ±5%, 150 VDCW 1/10W.
R244		Metal film: 100 ohms ±5%, 150 VDCW 1/10W.
R245 And R246		Metal film: 4.7k ohms ±5%, 150 VDCW 1/10W.
R247		Metal film: 1K ohms ±5%, 150 VDCW 1/10W.
R248 And R249		Metal film: 10K ohms ±5%, 150 VDCW 1/10W.
R250 Thru R253		Metal film: 100 ohms ±5%, 150 VDCW 1/10W.
R254		Metal film: 10K ohms ±5%, 150 VDCW 1/10W.
R255		Metal film: 15K ohms ±5%, 150 VDCW 1/10W.
R256		Metal film: 2.2K ohms ±5% 150 VDCW.1/10W.
R257		Metal film: 100 ohms ±5%, 150 VDCW 1/10W.
R258		Metal film: 33K ohms ±5%, 150 VDCW 1/10W.
R259		Metal film: 68 ohms ±5%, 200 VDCW 1/4W.
R260		Metal film: 1.8k ohms ±5%, 150 VDCW 1/10W.
R261 And R263		Metal film: 22K ohms ±5%, 150 VDCW 1/10W.
R264		Metal film: 2.7K ohms ±5%, 150 VDCW 1/10W.
R265		Metal film: 22K ohms 5%, 150 VDCW 1/10W.
R266		Metal film: 2.7K ohms ±5%, 150 VDCW 1/10W.
R267		Metal film: 22K ohms 5%, 150 VDCW 1/10W.
R268		Metal film: 2.7K ohms ±5%, 150 VDCW 1/10W.
		----- SWITCH -----
S201		Slide switch: sim to SMK JSC1210-0111.
		----- TRANSFORMER -----
T201		Transformer: sim to SUMIDA IS625.

SYMBOL	PART NO.	DESCRIPTION
		----- TRANSISTOR -----
TR201		Phototransistor: sim to SHARP PT370.
TR202 And TR203		Silicon NPN: sim to NEC 2SD596 (DV3.)
TR204 And TR205		Silicon, NPN: sim to SANYO 2SC3398 (DTC114EK)
TR206 And TR207		Silicon, PNP: sim to NEC 2SB624 (BV3).
TR208		Silicon, NPN: sim to TOSHIBA 2SC2712.
TR209		Silicon, NPN: sim to TOSHIBA 2SC2873.
TR210 And TR211		N-Channel Field Effect: sim to NEC 2SK1582.
TR212		Silicon, NPN: sim to NEC 2SC3736.
TR213		N-Channel Field Effect: sim to NEC 2SK1582.
		----- VACUUM FLUORESCENT DISPLAY -----
VFD201		VFD: sim to ISE ELECTRONICS DH0827A.
		----- CRYSTAL -----
X201		Crystal: F=7.3728 MHz.

SWITCH CIRCUIT
CDF-368B
(Used in P1, P2)

SYMBOL	PART NO.	DESCRIPTION
-----CAPACITORS-----		
C101 Thru C103		Ceramic: 0.1 F ±5% 50 VDCW, temp coef 0±30 PPM.
C104 Thru C110		Ceramic: 1000 pF +80%, -20% 50 VDCW, temp coef +22%, -82%.
----- DIODES-----		
CD101 Thru CD103		Silicon: fast recovery (2 diodes in cathode common); sim to TOSHIBA 1SS300.
CD104 Thru CD105		Optoelectronic: orange, sim to CITIZEN CL-150D-CD.
CD106		Optoelectronic: red, sim to CITIZEN CL-150UR-CD.
CD107 And CD108		Optoelectronic: orange, sim to CITIZEN CL-150D-CD.
CD109		Optoelectronic: red, sim to CITIZEN CL-150UR-CD.
CD110 And CD111		Optoelectronic: orange, sim to CITIZEN CL-150D-CD.
CD112		Optoelectronic: red, sim to CITIZEN CL-150UR-CD.
CD113 And CD114		Optoelectronic: orange, sim to CITIZEN CL-150D-CD.
CD115		Optoelectronic: red, sim to CITIZEN CL-150UR-CD.
CD116 And CD117		Optoelectronic: orange, sim to CITIZEN CL-150D-CD.
----- INTEGRATED CIRCUITS -----		
IC101		Linear: Positive Voltage Regulator; sim to TOSHIBA TA78L05F.
IC102		Digital, 8 BIT Shift Register; sim to MOTOROLA MC74HC595AF.
----- CONNECTORS-----		
J101		Connector: 30 pins.
J102		Connector: 9 pins.
----- RESISTORS-----		
R101		Metal film: 390 ohms ±5%, 100 VDCW 1/8W.
R102		Metal film: 3.3K ohms ±5%, 100 VDCW 1/8W.
R103		Metal film: 470 ohms ±5%, 100 VDCW 1/8W.
R104		Metal film: 3.3K ohms ±5%, 100 VDCW 1/8W.
R105		Metal film: 470 ohms ±5%, 100 VDCW 1/8W.
R106		Metal film: 3.3K ohms ±5%, 100 VDCW 1/8W.
R107		Metal film: 470 ohms ±5%, 100 VDCW 1/8W.
R108 And R109		Metal film: 3.3K ohms ±5%, 100 VDCW 1/8W.
----- TRANSISTOR-----		
TR101 Thru TR104		Silicon NPN: sim to SANYO 2SC3398-TB.

REMOTE INTERFACE ADAPTER
NQZ-4882
(Used in P2, P4)

SYMBOL	PART NO.	DESCRIPTION
-----CAPACITORS-----		
		Electrolytic: 100 µF ±20%, 25 VDCW.
----- CONNECTORS -----		
J1		Connector: 25 Pins.
J2		Connector: 18 Pins.
J3		Connector: 25 Pins.

SWITCH CIRCUIT
CDF-368M
(Used in P3, P4)

SYMBOL	PART NO.	DESCRIPTION
C101 thru C104	NOTE: Parts listed are for reference only. Refer to Service Section for serviceable parts.	Ceramic: 0.1 uF ±5% 50 VDCW, temp coef 0±30 PPM.
C105 thru C111		Ceramic: 1000pF +80%, -20% 50 VDCW, temp coef +22%, -82%.
----- DIODES -----		
CD101 thru CD106		Silicon: fast recovery (2 diodes in cathode common); sim to TOSHIBA 1SS300.
CD107		Optoelectronic: orange, sim to CITIZEN CL-150D-CD.
CD108		Optoelectronic: red, sim to CITIZEN CL-150UR-CD.
CD109		Optoelectronic: orange, sim to CITIZEN CL-150D-CD.
CD110		Optoelectronic: red, sim to CITIZEN CL-150UR-CD.
CD111		Optoelectronic: orange, sim to CITIZEN CL-150D-CD.
CD112		Optoelectronic: red, sim to CITIZEN CL-150UR-CD.
CD113		Optoelectronic: orange, sim to CITIZEN CL-150D-CD.
CD114		Optoelectronic: red, sim to CITIZEN CL-150UR-CD.
CD115		Optoelectronic: orange, sim to CITIZEN CL-150D-CD.
CD116		Optoelectronic: red, sim to CITIZEN CL-150UR-CD.
CD117		Optoelectronic: orange, sim to CITIZEN CL-150D-CD.
CD118		Optoelectronic: red, sim to CITIZEN CL-150UR-CD.
CD119		Optoelectronic: orange, sim to CITIZEN CL-150D-CD.
CD120		Optoelectronic: red, sim to CITIZEN CL-150UR-CD.
CD121		Optoelectronic: orange, sim to CITIZEN CL-150D-CD.
CD122		Optoelectronic: red, sim to CITIZEN CL-150UR-CD.
CD123		Optoelectronic: orange, sim to CITIZEN CL-150D-CD.
CD124		Optoelectronic: red, sim to CITIZEN CL-150UR-CD.
CD125		Optoelectronic: orange, sim to CITIZEN CL-150D-CD.
CD126		Optoelectronic: red, sim to CITIZEN CL-150UR-CD.
CD127		Optoelectronic: orange, sim to CITIZEN CL-150D-CD.
CD128		Optoelectronic: red, sim to CITIZEN CL-150UR-CD.
CD129		Optoelectronic: orange, sim to CITIZEN CL-150D-CD.
CD130		Optoelectronic: red, sim to CITIZEN CL-150UR-CD.
CD131		Optoelectronic: orange, sim to CITIZEN CL-150D-CD.
CD132		Optoelectronic: red, sim to CITIZEN CL-150UR-CD.
CD133		Optoelectronic: orange, sim to CITIZEN CL-150D-CD.
CD134		Optoelectronic: red, sim to CITIZEN CL-150UR-CD.
CD135		Optoelectronic: orange, sim to CITIZEN CL-150D-CD.
CD136		Optoelectronic: red, sim to CITIZEN CL-150UR-CD.
CD137		Optoelectronic: orange, sim to CITIZEN CL-150D-CD.
CD138		Optoelectronic: red, sim to CITIZEN CL-150UR-CD.
CD139		Optoelectronic: orange, sim to CITIZEN CL-150D-CD.
CD140		Optoelectronic: red, sim to CITIZEN CL-150UR-CD.
----- INTEGRATED CIRCUITS -----		
IC101		Linear: Positive Voltage Regulator; sim to TOSHIBA TA78L05F.
IC102 and IC103		Digital, 8 BIT Shift Register; sim to MOTOROLA MC74HC595AF.

SYMBOL	PART NO.	DESCRIPTION
----- CONNECTORS -----		
J101		Connector: 30 pins.
J102		Connector: 9 pins.
----- RESISTORS -----		
R101		Metal film: 270 ohms ±5%, 100 VDCW 1/8W.
R102		Metal film: 3.3K ohms ±5%, 100 VDCW 1/8W.
R103		Metal film: 270 ohms ±5%, 100 VDCW 1/8W.
R104		Metal film: 3.3K ohms ±5%, 100 VDCW 1/8W.
R105		Metal film: 270 ohms ±5%, 100 VDCW 1/8W.
R106		Metal film: 3.3K ohms ±5%, 100 VDCW 1/8W.
R107		Metal film: 270 ohms ±5%, 100 VDCW 1/8W.
R108 thru R116		Metal film: 3.3K ohms ±5%, 100 VDCW 1/8W.
R117		Metal film: 390 ohms ±5%, 100 VDCW 1/8W.
R118		Metal film: 3.3K ohms ±5%, 100 VDCW 1/8W.
R119		Metal film: 270 ohms ±5%, 100 VDCW 1/8W.
R120 thru R123		Metal film: 3.3K ohms ±5%, 100 VDCW 1/8W.
----- TRANSISTOR -----		
TR101 thru TR116		Silicon NPN: sim to SANYO 2SC3398-TB.

PRODUCTION CHANGES

Changes in the equipment to improve performance or to simplify circuits are identified by a "Revision Letter", which is stamped after the model number on the unit. The revision stamped on the unit includes all previous revisions. Refer to the Parts List for the description of parts affected by these revisions.

REV. A - Control Unit 344A4581P1 thru P4

To improve "O" ring moisture seal. Added more silicone grease to the "O" ring. Refer to procedure in the appropriate Service Section.

REV. B - Control Unit 344A4581P1 thru P4

To eliminate "sneak" current path on S/L ON/OFF switched output. Deleted diode CD225.

REV. C - Control Unit 344A4581P1 thru P4

To improve multi-mode operation, software upgraded.

COMPONENT SIDE

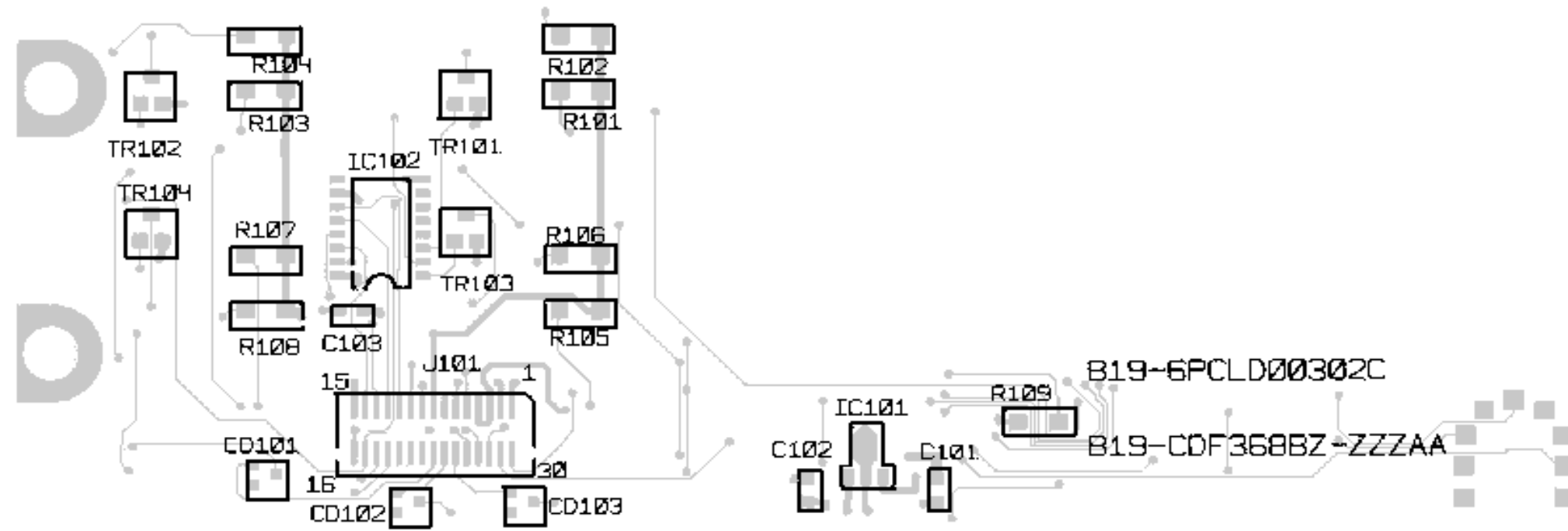

SOLDER SIDE

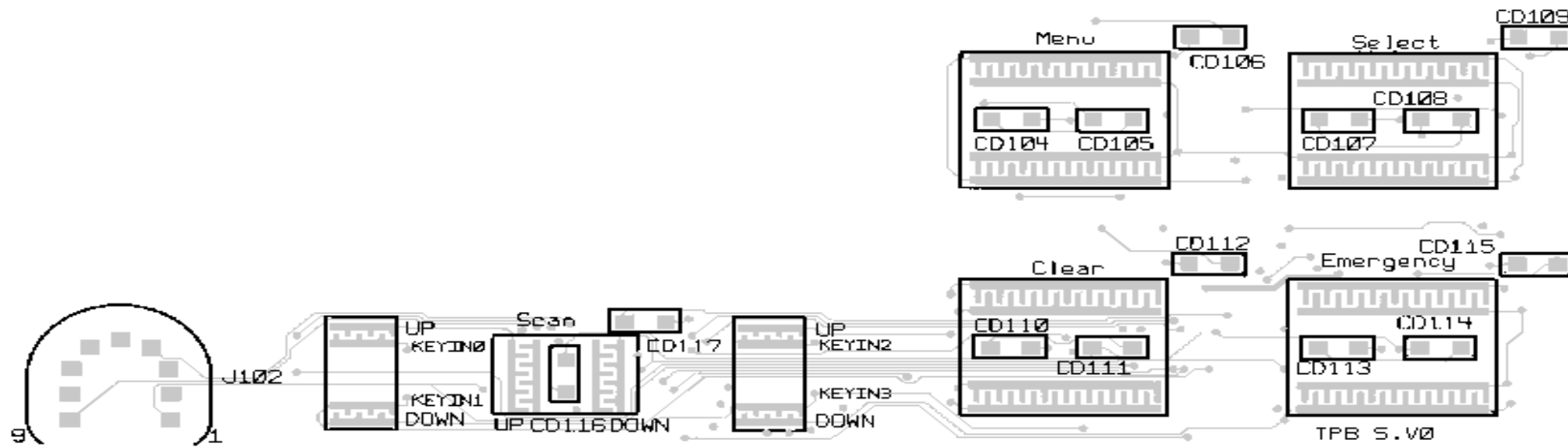

SWITCH CIRCUIT
CDF-368B

COMPONENT SIDE

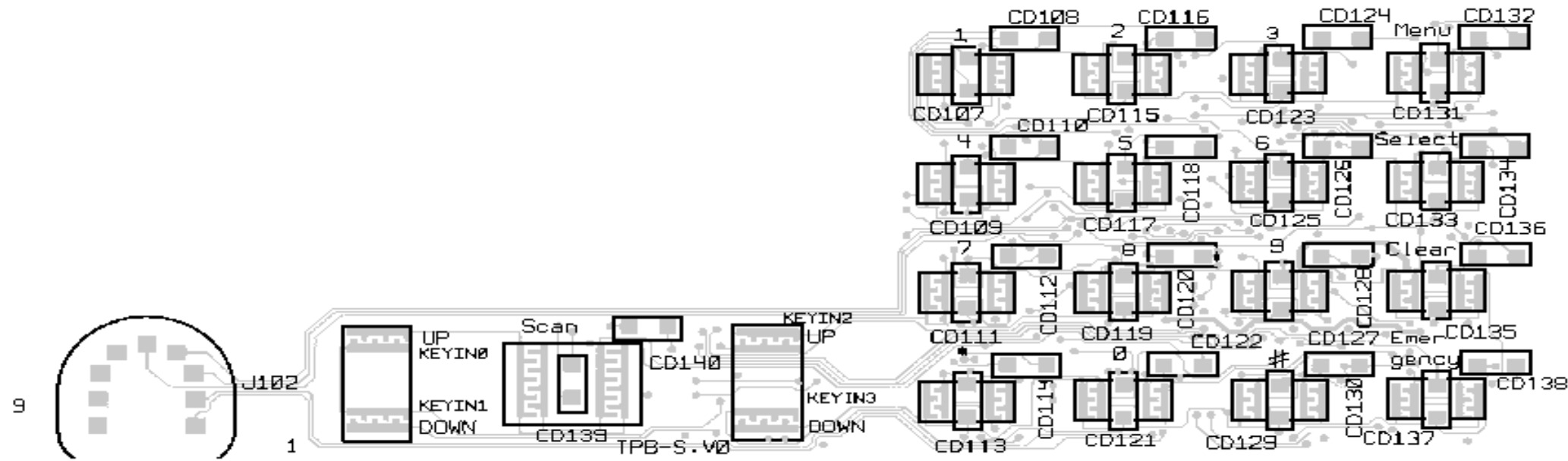

SOLDER SIDE

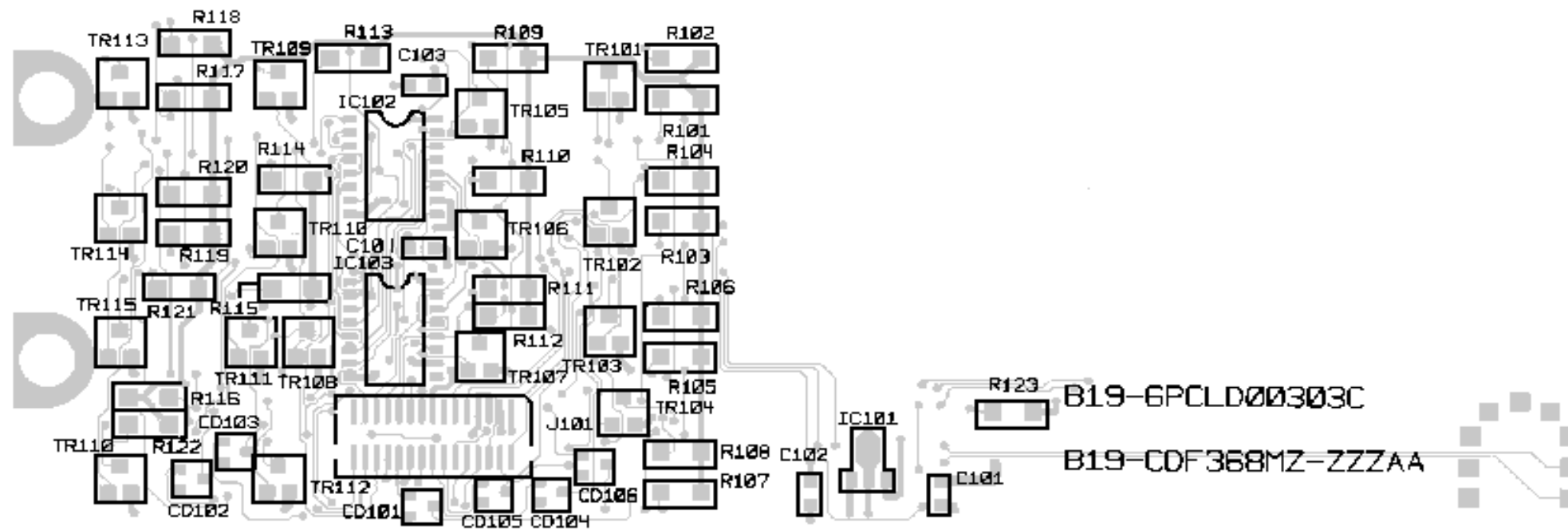

SWITCH CIRCUIT
CDF-368M

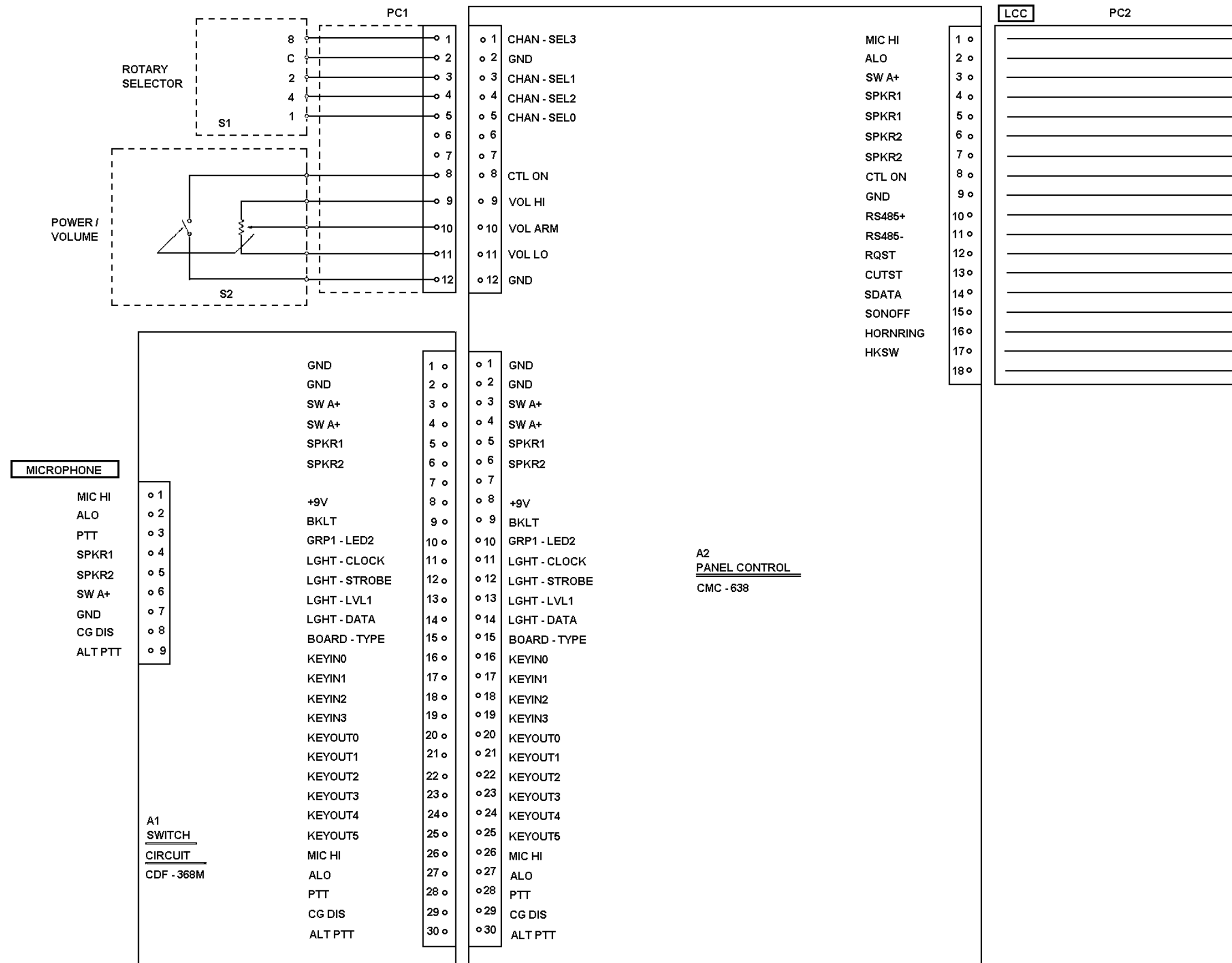

CONTROL UNIT (LOCAL TYPE)
(DD00-CDM-556ML)

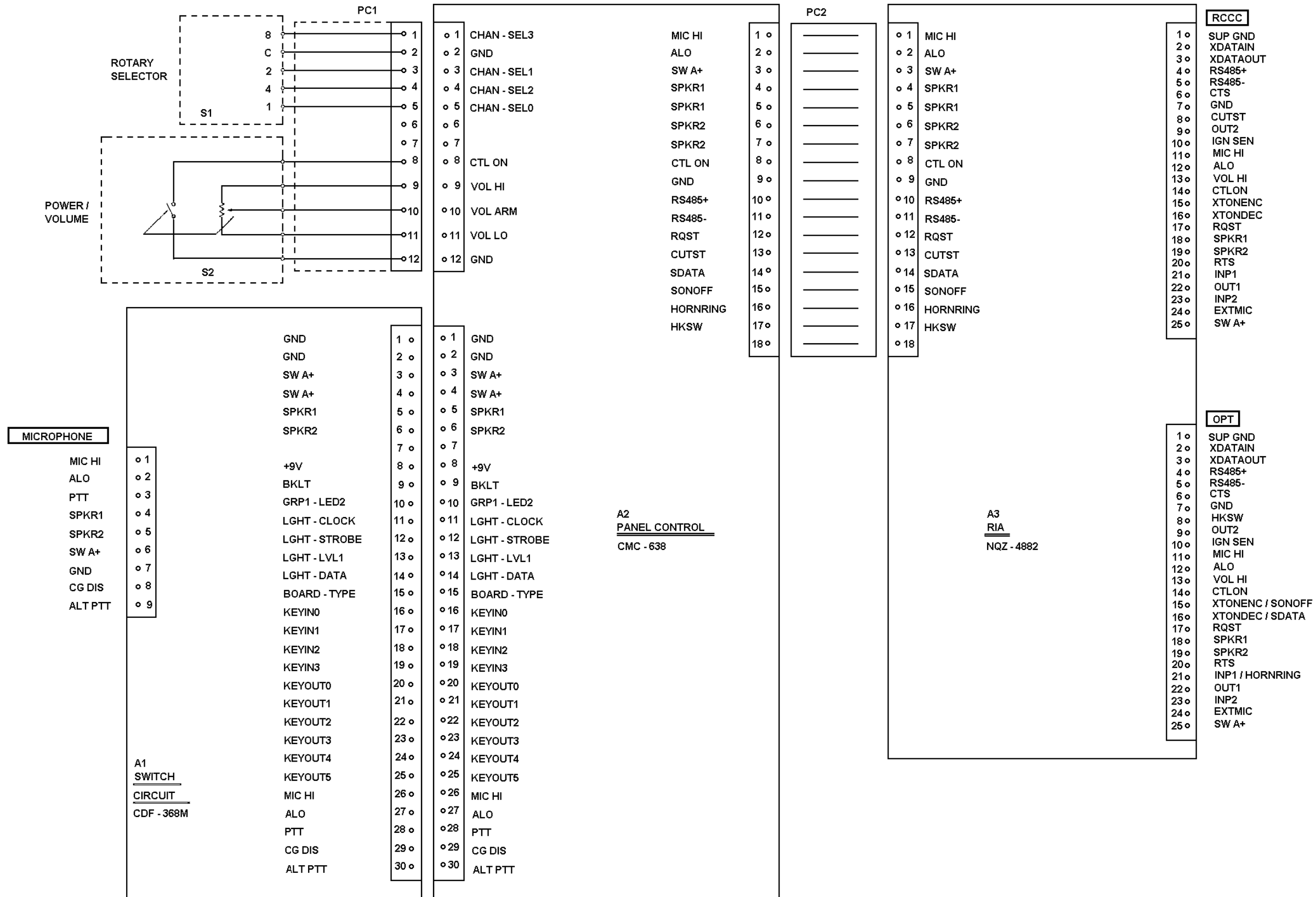

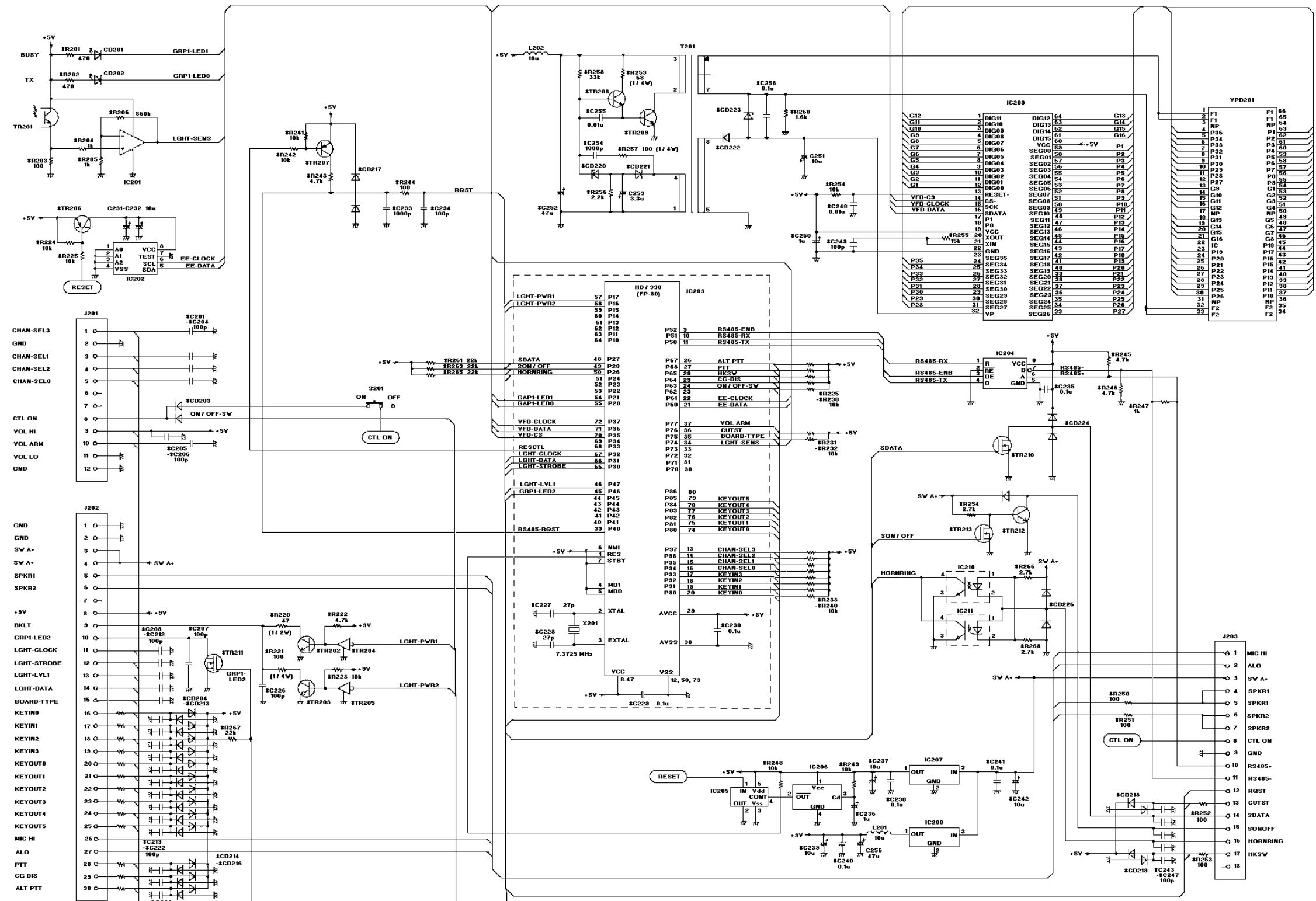

NOTES: "*" IDENTIFIES "CHIP" COMPONENTS (EXAMPLE: #R201)
 ALL RESISTORS ARE 1/8 WATT UNLESS OTHERWISE SPECIFIED.
 RESISTOR VALUES IN Ω UNLESS FOLLOWED BY MULTIPLIER k, CAPACITOR VALUES IN F UNLESS FOLLOWED BY MULTIPLIER μ OR p.

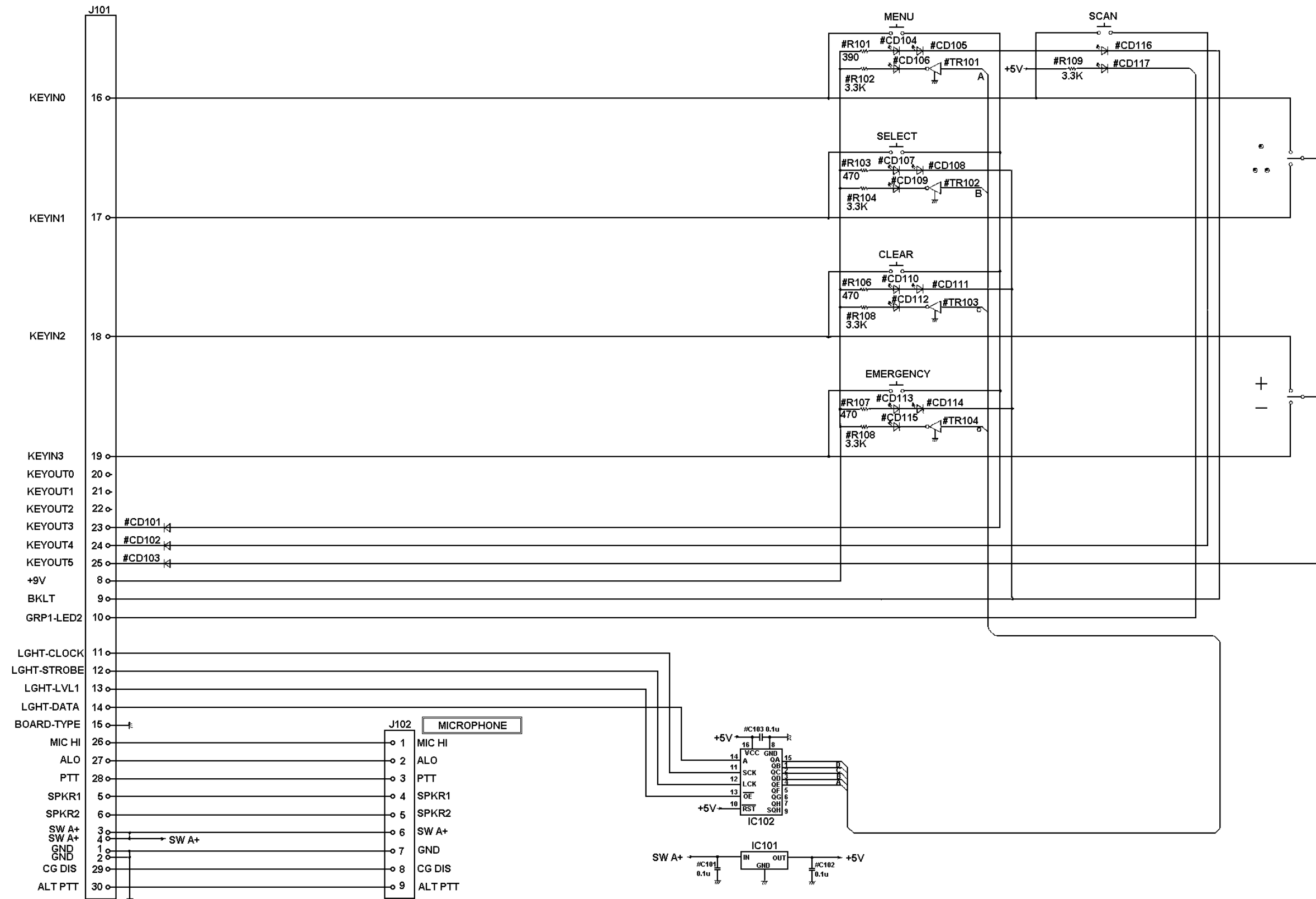

ASM NO. 819-CDF368BZ-ZZZAA
 PCS NO. 819-6PCLD00302

NOTES: "*" IDENTIFIES "CHIP" COMPONENTS (EXAMPLE: #R201)
 ALL RESISTORS ARE 1/16 WATT UNLESS OTHERWISE SPECIFIED.
 RESISTOR VALUES IN Ω UNLESS FOLLOWED BY MULTIPLIER K.
 CAPACITOR VALUES IN F UNLESS FOLLOWED BY MULTIPLIER μ OR p.

SWITCH CIRCUIT (BASIC MODEL)

(DD00-CDF-368B)

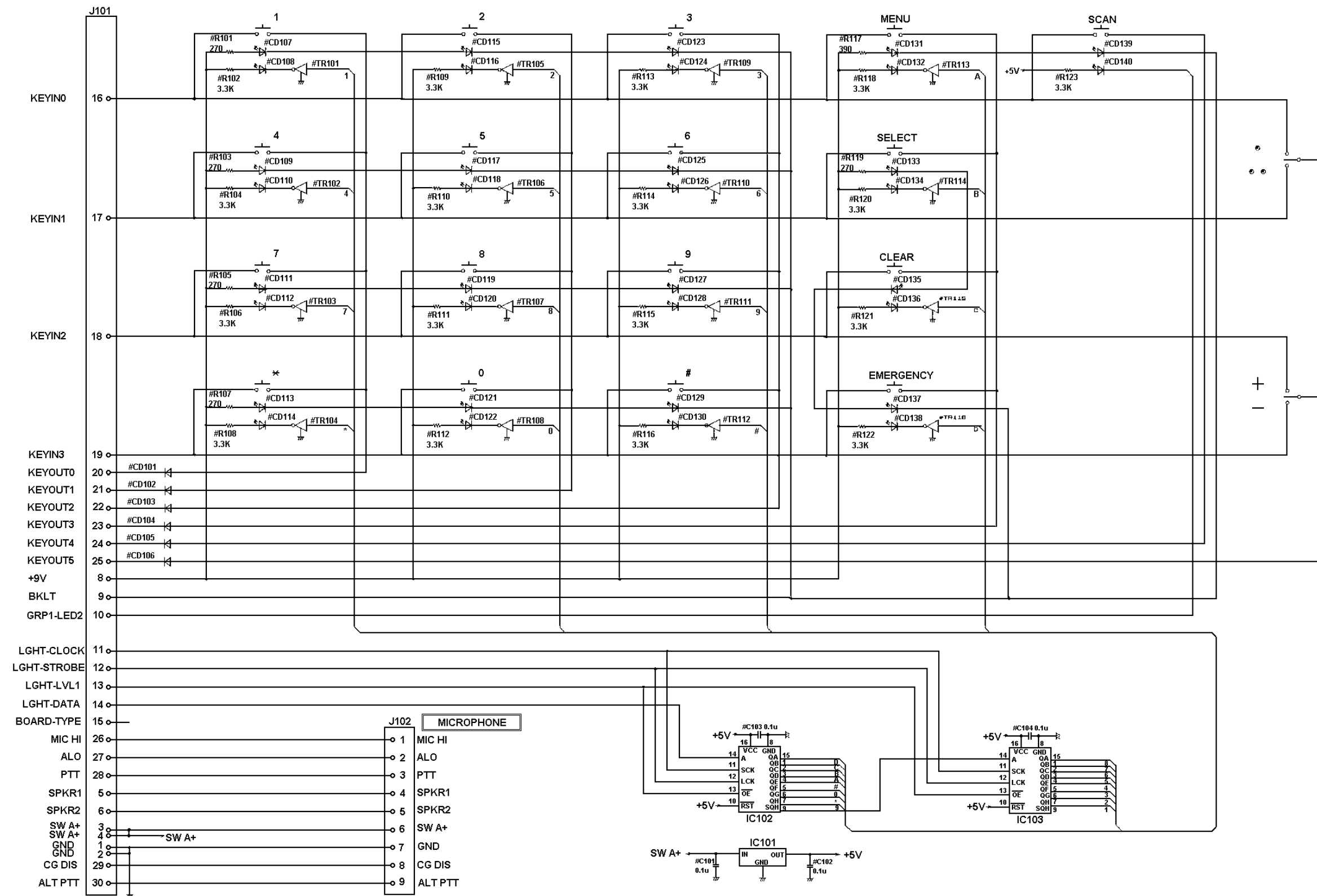

ASM NO. 819-CDF368MZ-ZZZAA
PCS NO. 819-6PCLD00303

NOTES: * IDENTIFIES "CHIP" COMPONENTS (EXAMPLE: #R201)
ALL RESISTORS ARE 1/16 WATT UNLESS OTHERWISE SPECIFIED.
RESISTOR VALUES IN Ω UNLESS FOLLOWED BY MULTIPLIER K, M, OR P.
CAPACITOR VALUES IN F UNLESS FOLLOWED BY MULTIPLIER μ OR p.

SWITCH CIRCUIT (MID MODEL)

(DD00-CDF-368M)