

**MAINTENANCE MANUAL
ORION
PA INTERFACE BOARDS
CMH-1231LB
CMH-1231L/H
CMH-1231E**

TABLE OF CONTENTS

	<u>Page</u>
DESCRIPTION	1
PARTS LISTS:	
LOW BAND PA INTERFACE (CMH-1231LB)	4
VHF/UHF/LOW POWER PA INTERFACE (CMH-1231L)	4
VHF/UHF HI POWER WER PA INTERFACE (CMH-1231H)	4
VHF/UHF EUROPEAN PA INTERFACE (CMH-1231E)	4
OUTLINE DIAGRAMS:	
LOW BAND PA INTERFACE (CMH-1231LB)	5
VHF/UHF/LOW POWER PA INTERFACE (CMH-1231L)	6
VHF/UHF HI POWER WER PA INTERFACE (CMH-1231H)	6
VHF/UHF EUROPEAN PA INTERFACE (CMH-1231E)	7
SCHEMATIC DIAGRAMS:	
LOW BAND PA INTERFACE (CMH-1231LB)	8
VHF/UHF/LOW POWER PA INTERFACE (CMH-1231L)	9
VHF/UHF EUROPEAN PA INTERFACE (CMH-1231E)	10

DESCRIPTION

PA Interface Boards CMH-1231LB, CMH-1231L/H and CMH-1231E interface power connections, speaker connections, PA module connections and most other connections of the **ORION** Mobile radio. Low band PA Board CMH-

1231LB consists of one forty pin RF Connector, P1001 and one thirty-seven pin connector, J1003.

VHF/UHF PA Interface boards consist of two, twenty-four pin, RF connectors, P1001 and P1002, and one thirty-seven pin connector J1003. Signals interfaced are defined in Table 1.

Table 1 - Interface Lead Definition

CONNECTOR J1003 PIN NUMBER	LEAD LABEL	SOURCE	DEFINITION	
1	SUP GND	Radio	Supply GND for accessories	
2	XDATAIN	External	MDT Serial Data 9.6 kbd maximum RS-232C compatible Specs.	Used for Programming Only
3	XDATAOUT	Radio	MDT Serial Data 9.6 kbd maximum RS-232C compatible Specs.	Used for Programming Only
4	RS485+	Bidirectional	Data signal between Radio Unit and Control Unit	
5	RS485-	Bidirectional	Second line of Radio Unit-Control unit data bus	
6	CTS	Radio	Clear-To-Send signal for MTD RS-232C compatible Spec.	Usage Optional
7	GND	Radio	Ground return for DC (2 amp. Max)	
8	FPROG	Control Unit	Field Programming Input Active=+12V, Inactive=0V Sink 50 ma	
9	OUT2	Radio	Accessory switch Active=0V, Inactive=O.C. Realy Driver Sink 500 ma.	(Must supply Reverse Kick Diode)
10	IGN SEN	Radio	Active=A+, Inactive= O.C.	
11	MIC HI	Control Unit	Microphone Audio (300-3000 Hz) 600 Ohm Load (AC) Carries 9 Vdc for Microphone Power (1360 ohm source impedance, DC)	55-110 mv for 60% Deviation
12	ALO	Radio	Ground return for MIC HI	
13	VOL HI	Radio	Low Power De-emphasized, volume controlled audio Drives 600 Ohms Load (AC coupled)	500 mv RMS typical at rated audio output
14	CTL ON	Control Unit	On/Off Control Active (0V), Inactive (O.C.)	
15	XTONEENC	External	External tone input (non-pre-emphasized)	2.2 k load
16	XTONEDEC	Radio	External tone output (non de-emphasized)	500 mv RMS typical
17	RQST	Bidirectional	REQUEST Signal for RS-485 Data Bus Active=0V, Inactive=O.C.	
18	SPKR1	Radio	Speaker Output Pins 18 and 19 are a balanced pair driving a 4 ohm speaker	DO NOT connect to ground.
19	SPKR2	Radio	Speaker Output Pins 18 and 19 are a balanced pair driving a 4 ohm speaker	DO NOT connect to ground.
20	RTS	External	Request-To-Send signal from MDT RS-232C compatible specs.	Usage optional

Continued

CONNECTOR J1003 PIN NUMBER	LEAD LABEL	SOURCE	DEFINITION	
21	INP1	External	Accessory Input Active=0V, Inactive=O.C. Source 10 ma maximum	22k pullup INTERNAL
22	OUT1	Radio	Same Spec as Pin 9	
23	INP2	External	Same Spec as Pin 21	
24	IGN A+	External	Input from Ignition Switch Connected to IGN SEN in Radio	
25	SW A+	Radio	Switched A+ Power 700 ma Maximum	
26	HKSW	External	External Hookswitch Input Active=0V, Inactive=O.C.	
27	EXTMIC	External	External Microphone Input 300-3000 Hz	
55 - 110 mv for 60% Deviation	2.2k Impedance AC coupled			
28	EXTRX	External	Input from receiver on 2nd radio Driven by VOL HI source 600 Ohm load AC coupled, 10 Hz minimum frequency	If used
29	FDISC	Radio	Filtered Discriminator Output Internal load 1k DC coupled	Not De-emphasized Used mainly for TEST
30	EXTALO	Radio	Analog GND For 2nd microphone	Optional
31	CUTST	2 Function	Signal Control Unit to self test	
32	A+/SPARE	2 Function	EUROPEAN Models Power A+ USA Models - Not Used	DO NOT Connect for USA Models
33	A+/SPARE	2 Function	EUROPEAN Models Power A+ USA Models - Not Used	DO NOT Connect for USA Models
34	A+/SPARE	2 Function	EUROPEAN Models Power A+ USA Models - Not Used	DO NOT Connect for USA Models
35	A-/SDATA	2 Function	EUROPEAN Models Power A+ USA Models Federal Signal Siren Interface	1200 Baud data for Siren/Light Control
36	A-/SONOFF	2 Function	EUROPEAN Models Power A- USA Models Federal Signal Siren Interface	On/Off Signal for Siren/Light Control
37	HORNRING		Federal Signal Siren Interface	Horn switch control - optional

**ORION LOW BAND PA INTERFACE
CMH-1231LB
(Used in 344A4576P1/P2) (60 Watt)
(Used in 344A4573P3/P4) (110 Watt)**

SYMBOL	PART NO.	DESCRIPTION
		-----CAPACITORS-----
C1003	NOTE: Parts listed are for reference only. Refer to Service Section for serviceable parts	Ceramic:1000 pF +200%,50 VDCW temp coef +20%,-55%
C1004		Ceramic:1000 pF +200%,50 VDCW temp coef +20%,-55%
C1005 thru C1019		Ceramic: 1000 pF ±10% 50 VDCW, temp coef ±15%.
C1020		Ceramic: 100 pF ±5% 50 VDCW, temp coef 0±60PPM.
C1021 thru C1040		Ceramic: 1000 pF ±10% 50 VDCW, temp coef ±15%.
		-----CONNECTORS-----
J1003		Connector:D-SUB 37 PIN (FEMALE)
P1001		Connector: SMT 40 PIN (MALE)
		-----FLEXIBLE PCB-----
PC1001		H-6PCLD00350B.
		-----WIRES-----
ZC1001		H-6ZCLD00169
ZC1002		H-6ZCLD41060
ZC1003		H-6ZCLD41060

*COMPONENTS, ADDED, DELETED OR CHANGED BY PRODUCTION CHANGES

**ORION PA INTERFACE
CMH-1231L
(Used in 344A4572P3, P4, P5) (VHF)
(Used in 344A4573P3, P4, P5) (UHF)**

SYMBOL	PART NO.	DESCRIPTION
		-----CAPACITORS-----
C1005 thru C1019	NOTE: Parts listed are for reference only. Refer to Service Section for serviceable parts	Ceramic: 1000 pF ±10% 50 VDCW, temp coef ±15%.
C1020		Ceramic: 100 pF ±5% 50 VDCW, temp coef 0±60PPM.
C1021 thru C1040		Ceramic: 1000 pF ±10% 50 VDCW, temp coef ±15%.
		-----CONNECTORS-----
J1003		Connector.
P1001 and P1002		Connector: RF.
		--- PRINTED CIRCUIT BOARD ---
PC1001		H-6PCLD00327.

*COMPONENTS, ADDED, DELETED OR CHANGED BY PRODUCTION CHANGES

**ORION INTERFACE
CMH-1231H
(Used in 344A4572P6, P7, P8) (VHF)
(Used in 344A4573P6, P7, P8) (UHF)**

SYMBOL	PART NO.	DESCRIPTION
		-----CAPACITORS-----
C1005 thru C1019	NOTE: Parts listed are for reference only. Refer to Service Section for serviceable parts	Ceramic: 1000 pF ±10% 50 VDCW, temp coef ±15%.
C1020		Ceramic: 100 pF ±5% 50 VDCW, temp coef 0±60PPM.
C1021 thru C1040		Ceramic: 1000 pF ±10% 50 VDCW, temp coef ±15%.
		-----CONNECTORS-----
J1003		Connector.
P1001 and P1002		Connector: RF.
		--- PRINTED CIRCUIT BOARD ---
PC1001		H-6PCLD00314B.

*COMPONENTS, ADDED, DELETED OR CHANGED BY PRODUCTION CHANGES

**ORION INTERFACE
CMH-1231E
(Used in 344A4572, P1, P2) (VHF)
(Used in 344A4573P1, P2) (UHF)**

SYMBOL	PART NO.	DESCRIPTION
		-----CAPACITORS-----
C1003 thru C1016	NOTE: Parts listed are for reference only. Refer to Service Section for serviceable parts	Ceramic: 1000 pF ±10% 50 VDCW, temp coef ±15%.
C1017		Ceramic: 100 pF ±5% 50 VDCW, temp coef 0±60PPM.
C1018 thru C1033		Ceramic: 1000 pF ±10% 50 VDCW, temp coef ±15%.
		-----FERRITE BEAD-----
FB1001 thru FB1008		Ferrite Bead: B-20F-28.
		---- FLEXIBLE PRINTED CIRCUIT BOARD
FPC1001		H-6PCLD00320B
		-----CONNECTORS-----
J1003		Connector.
P1001 and P1002		Connector: RF.
		-----COAXIAL CABLE-----
ZC1001		H-6ZCLD00128

*COMPONENTS, ADDED, DELETED OR CHANGED BY PRODUCTION CHANGES

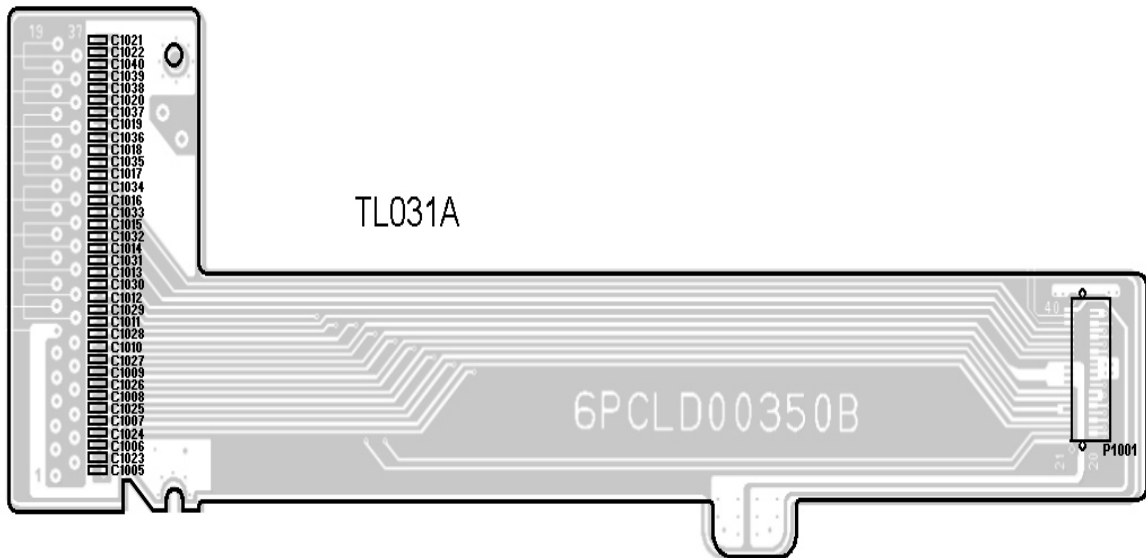

LOW BAND PA INTERFACE

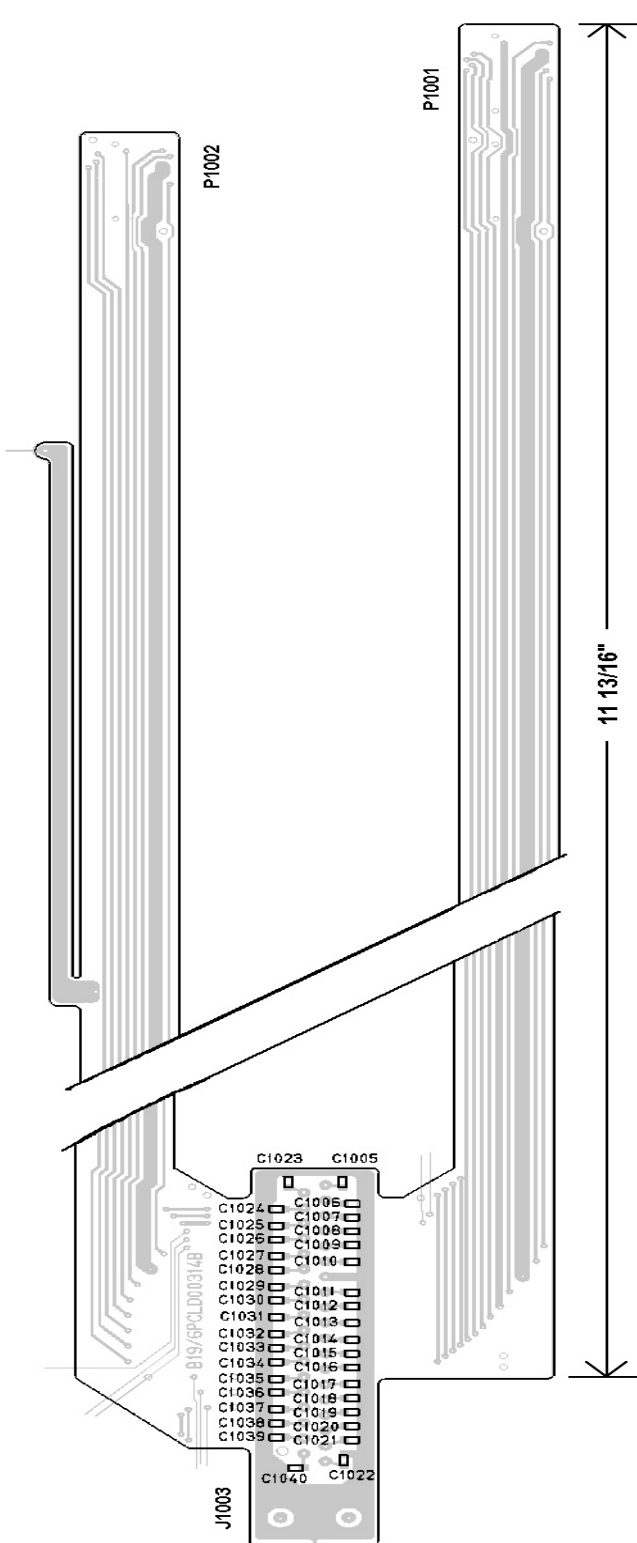

LOW POWER PA INTERFACE

(B19/6PCLD00327, Rev. 0)

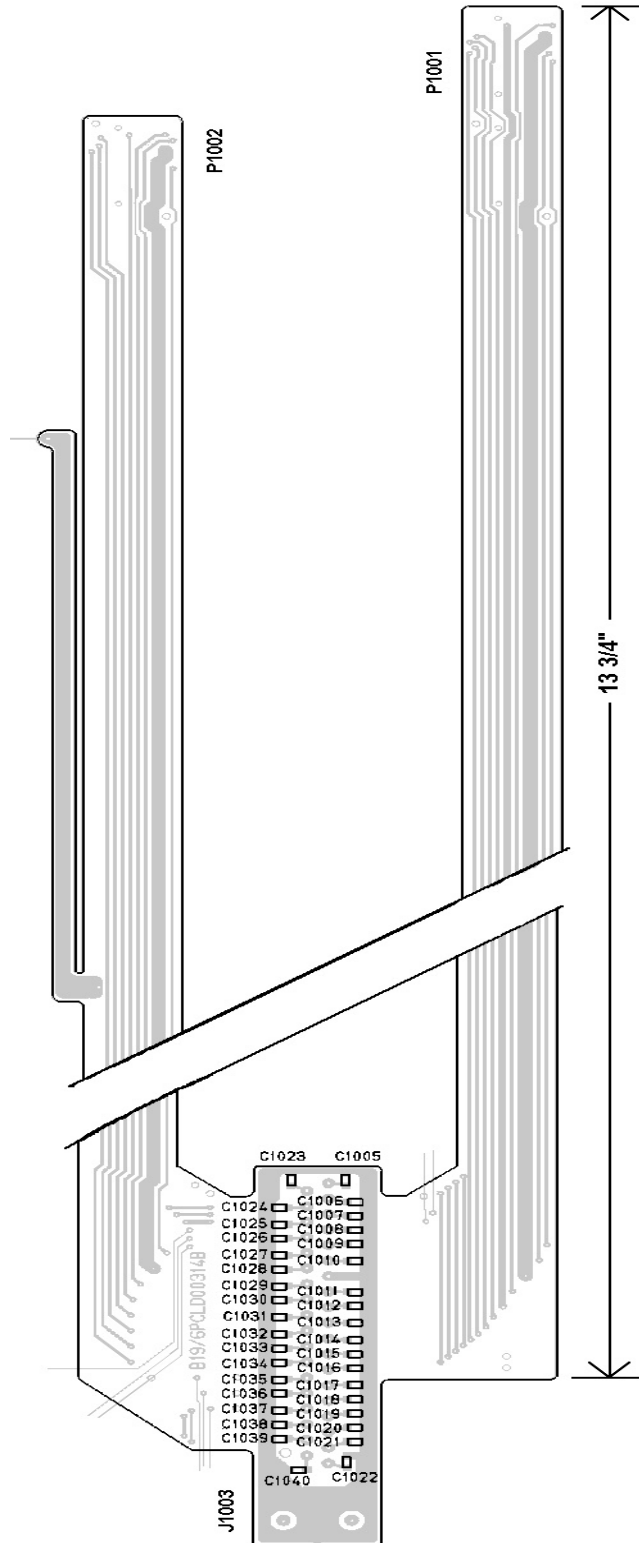

HIGH POWER PA INTERFACE

(B19/6PCLD00314, Rev. 0)

COMPONENT SIDE

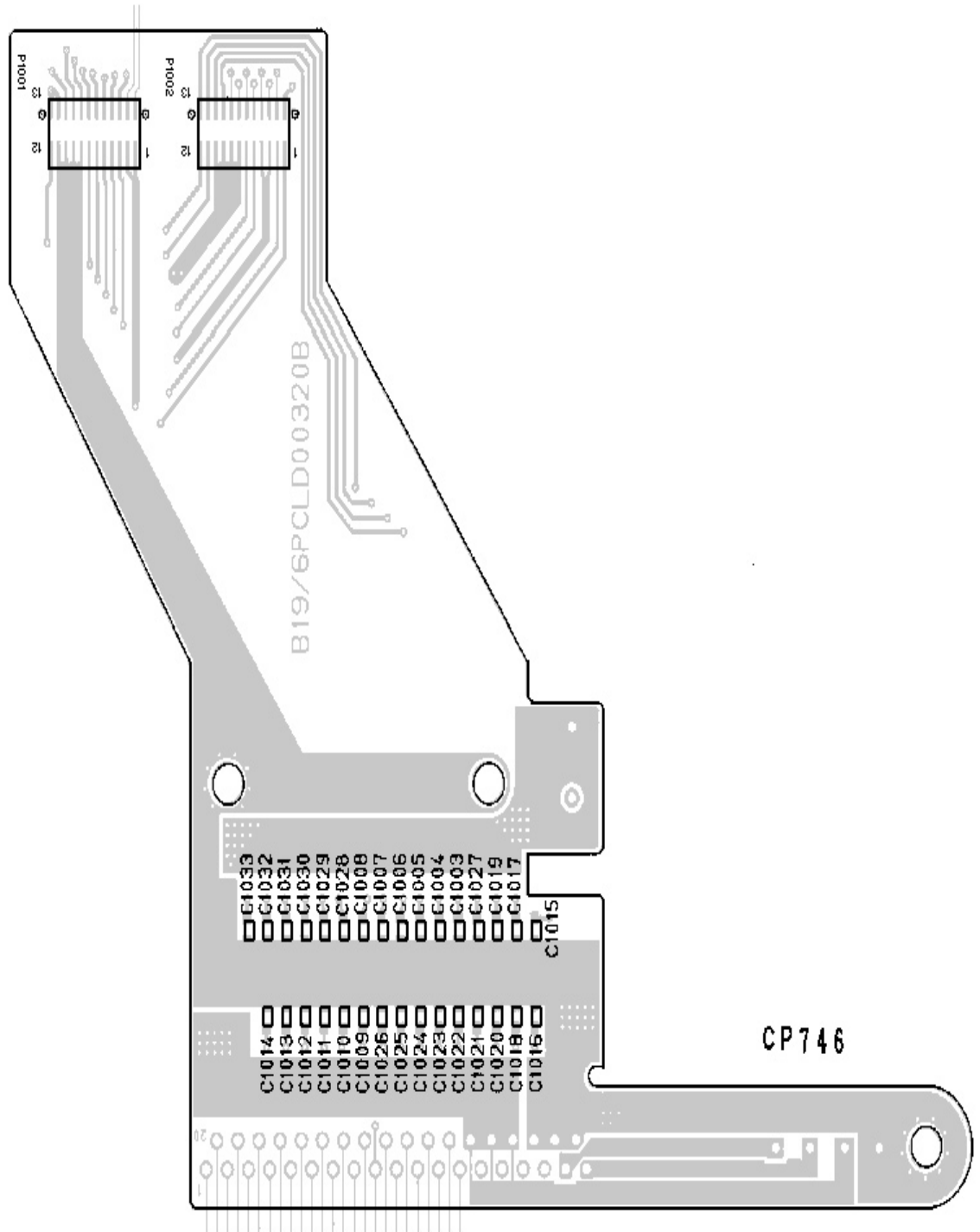

EUROPEAN PA INTERFACE

(B19/6PCLD00320B)

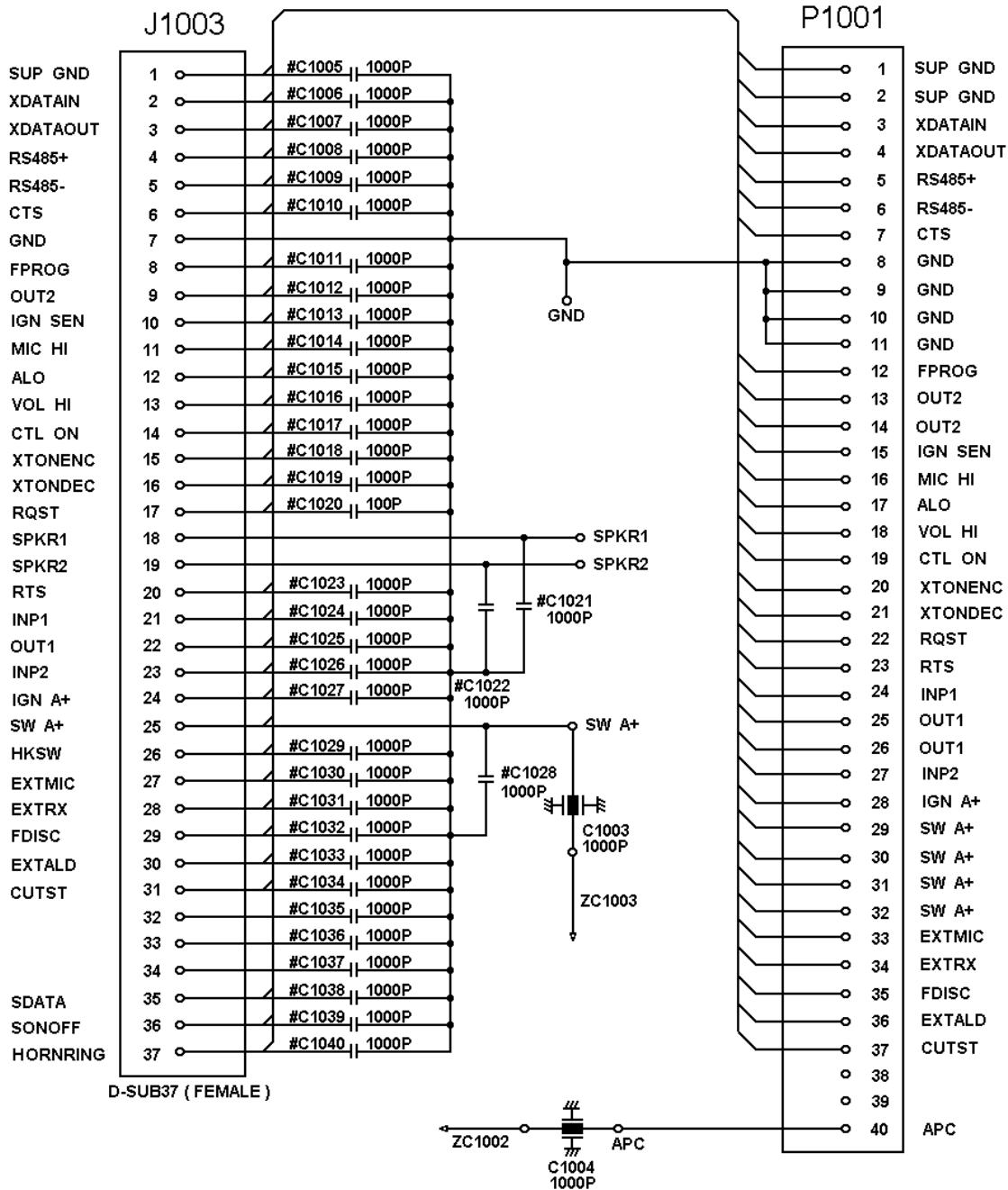

LOW BAND PA INTERFACE

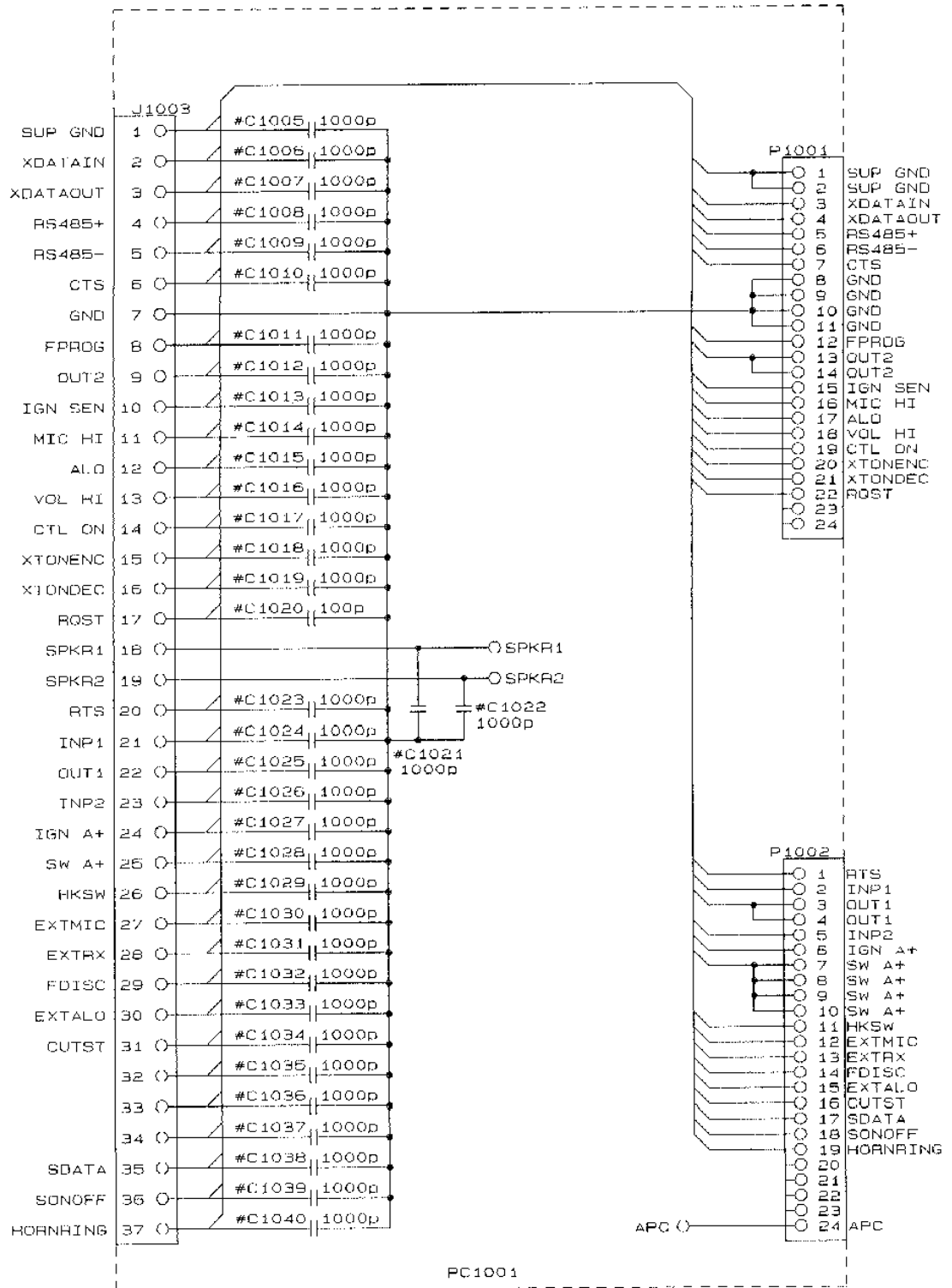

PA INTERFACE

(DD00-CMH-1231L/H)

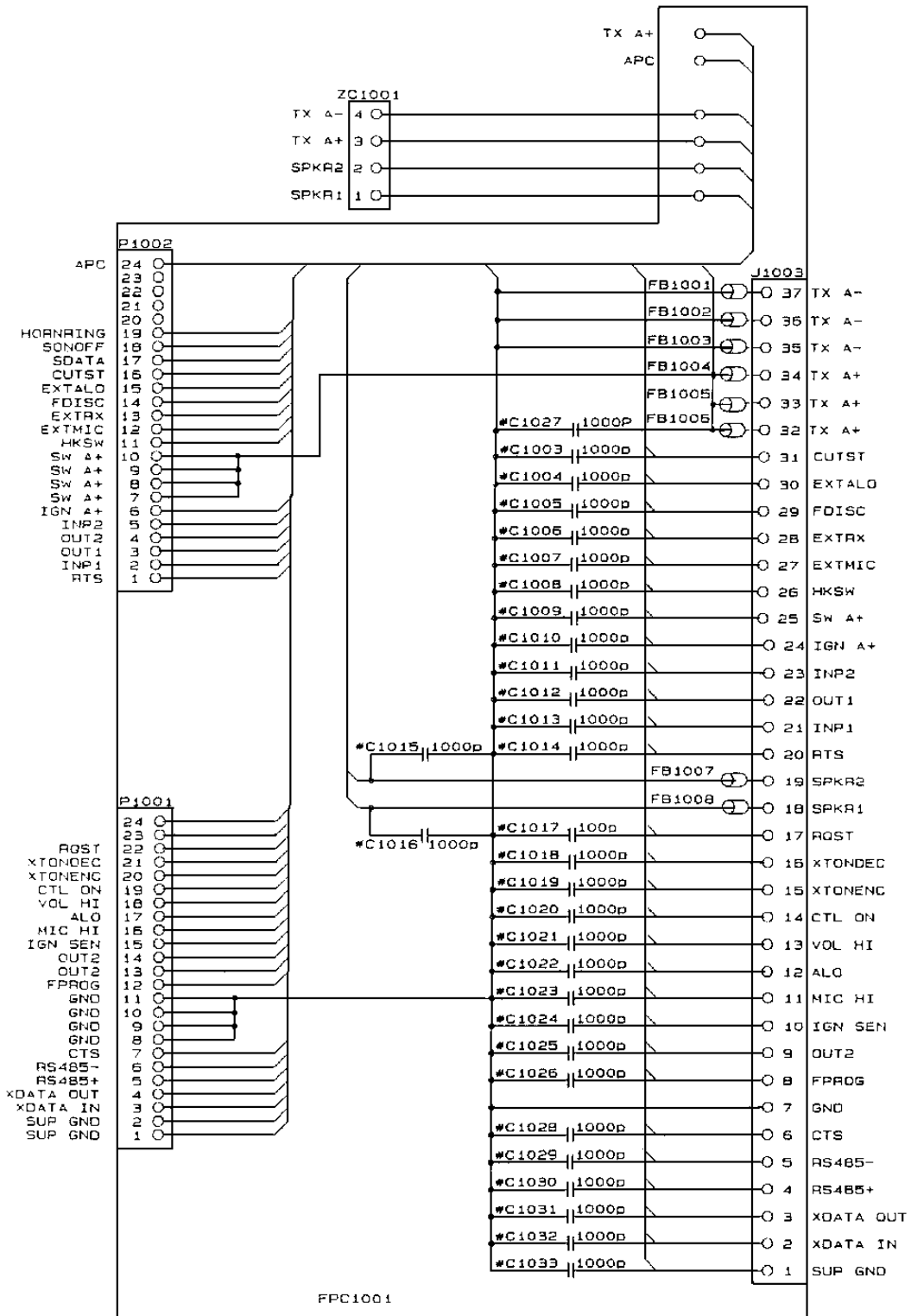

EUROPEAN PA INTERFACE

(DD00-CMH-1231E)

This page intentionally left blank

Ericsson Inc.

Private Radio Systems

Mountain View Road

Lynchburg, Virginia

1-800-528-7711 (Outside USA, 804-528-7711)

Printed in U.S.A.