



Mobile Communications



MDX™ SERIES

(Conventional Mobile Radio)
MOBILE RADIO

Installation Manual

TABLE OF CONTENTS

INTRODUCTION	3
UNPACKING AND CHECKING EQUIPMENT	3
PLANNING THE INSTALLATION	5
EQUIPMENT REQUIRED	6
INSTALLATION IN VEHICLES POWERED BY LIQUEFIED (LP) GAS	7
MOUNTING LOCATION	7
INSTALLATION	8
RUNNING CABLES	8
MOUNTING THE RADIO	11
MICROPHONE HANGER	12
MICROPHONE	14
MOBILE OPTIONS INSTALLATION	14
ANTENNA - OPTION PMAN1_	14
OPTION CABLE KIT - OPTION PMCD7Z (19C851585P14)	15
POWER CABLE - OPTION PMCD9A (19B801358P17)	18
MICROPHONE, MIL SPEC - OPTION PMMC3W (344A4528P55)	18
NOISE SUPPRESSION KIT - OPTION PMPD1A (19A148539G1)	18
ALARM (HORN) RELAY KIT - OPTION PMSU1C (19A705499P1)	19
EXTERNAL SPEAKER KIT - OPTION PMZM1K	21
BRAMCO DECODER INSTALLATION NOTES	22
OPTION INTERCONNECTION DIAGRAMS	23

INTRODUCTION

This manual contains installation instructions for the MDX Mobile Radio series and associated accessories. These instructions cover the mounting and cabling of the radio; interconnection diagrams are provided at the back of the manual for reference. Before installation, the radio should be programmed using an IBM compatible personal computer and the following items:

Serial Programming Interface Module Kit and Programming Cable	TQ3370 TQ3372
MDX Series Programming Software (Conventional Mobile Radio)	TQ3346

UNPACKING AND CHECKING EQUIPMENT

When ready for installation, carefully unpack the radio and identify each item in the shipping container as listed below. If damage has occurred to the equipment during shipment, file a claim with the carrier immediately. The available options for the MDX Mobile Radio series are covered in Table 1.

<input type="checkbox"/> MDX Mobile Radio	
<input type="checkbox"/> Microphone	344A4528P1
<input type="checkbox"/> Microphone hanger	344A4678P1
<input type="checkbox"/> Power cable, 9 feet	19B801358P18
<input type="checkbox"/> Mounting bracket kit	19A138051G11
<input type="checkbox"/> Operator's Manual	LBI-39012
<input type="checkbox"/> Installation Manual	LBI-39013

Table 1 - MDX Mobile Radio Series Optional Accessories

Option	Description	Part Number
PMAN1R	Roof mount antenna with TNC connector	
PMCC02	Universal tone cable (used with V8001, V8022, V8024, each).	
PMCC9M	External speaker cable, 18 inches	19A149590P8
PMCD1W	External speaker cable, 16 feet, requires option PMZM1K and PMCD7Z	19A149590P10
PMCD7C	9' power cable	
PMCD7Z	External option cable, 2 feet	19C851585P14
PMCD9A	Power cable, 18 feet	19801358P17
PMLS1F	Speaker, MIL-STD-810C & D, 5" x 5", requires options PMCD7Z & PMCC9M	19A149590P1
PMMC3X	Desk microphone for station use.	19C851086P14
PMMA1L	Desk mounting wedge for station use.	19C851685G2
PMMA1M	Spare mounting bracket	
PMMC5K	DTMF microphone	
PMMK3D	Round pushbutton kit with commonly used legends. Includes button extraction tool.	344A4254G2
PMPD1A	Noise suppression kit	19A148539G1
PMPS1C	Power supply, 120/240V, 50/60 Hz, 13 A. For station use.	19A704647P2
PMPS1D	Power supply, 240V AC, 50/60 Hz, 13 A. For station use.	19A704647P3
PMSU1C	Alarm (horn) relay kit, requires option PMCD7Z	19A705499P1
PMSU5A	Public address relay kit & external speaker kit.	
PMZM1K	External speaker kit, requires option PMCD7Z, includes options PMLS1F and PMCC9M	
PMZM5R	Microphone, MIL SPEC	
PMZM55	Remote mount kit	
V5018	Slide & mounting brackets	
V5026	Slide & mounting brackets	
V5027	Slide & mounting brackets	
V5028	Slide & mounting brackets	
V8001	DTMF encoder	

PLANNING THE INSTALLATION

Before starting, plan the radio installation carefully so that it will be:

- safe for the operator and passengers.
- convenient for the operator to use.
- neat.
- protected from water damage.
- easy to service.
- out of the way of auto mechanics.
- out of the way of passengers.

It is suggested that the radio be installed by one of the many authorized General Electric Service Stations located throughout the United States. These experienced service stations can provide a proper radio installation and make any final adjustments that may be needed.

WARNING

Interference with Vehicular Electronics - Electronic fuel injection systems, electronic anti-skid braking systems, electronic cruise control systems, etc., are typical of the types of electronic devices which may be prone to malfunction due to the lack of protection from radio frequency energy present when transmitting. If the vehicle contains such equipment, consult the dealer for the make of vehicle and enlist his aid in determining if such electronic circuits will perform normally when the radio is transmitting.

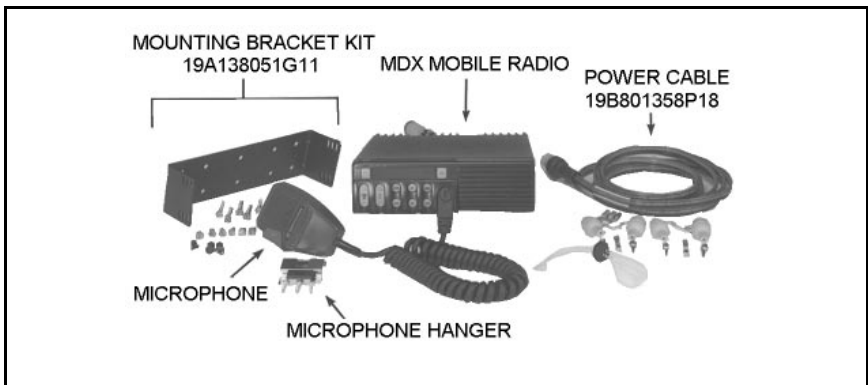

Figure 1 - MDX Components and Mounting Hardware

EQUIPMENT REQUIRED

The equipment required for installing the MDX Mobile Radio is listed below:

- Electric drill for drilling mounting holes.
- Drills and circle cutters as follows:
 - No. 31 (1/8-inch) drill for No. 8 self-tapping screws.
 - No. 27 (9/64-inch) drill for No. 10 self-tapping screws.
 - 5/8-inch drill or circle cutter for power cable.
 - 3/4-inch circle cutter, hole saw or socket punch for antenna (optional).
- Phillips and flat-blade screwdrivers, and 1/4-inch and 5/16-inch hex-head drivers for mounting screws.
- No. 15 Torx® driver (ST0606).
- No. 15 Torx® tamper-proof driver (ST0618) if latch security screw (supplied in hardware kit) is used.
- No. 25 Torx® driver (ST0610).
- POZIDRIV® driver for mounting screws.

Torx® is a registered trademark of CAMCAR Division TEXTRON, Inc.

POZIDRIV® is a registered trademark of Phillips International Company.

CAUTION

Be careful to avoid damaging some vital part (fuel tank, transmission housing, etc.) of the vehicle when drilling mounting holes. Always check to see how far the mounting screws will extend below the mounting surface before installing.

CAUTION

If pilot holes must be drilled, remove all metal shavings from drilling holes before installing screws.

WARNING

Radio installations in vehicles powered by liquefied petroleum gas must conform to the following requirements.

INSTALLATION IN VEHICLES POWERED BY LIQUEFIED (LP) GAS

Radio installation in vehicles powered by liquefied petroleum gas with the LP-gas container in the trunk or other sealed-off space within the interior of the vehicle must conform to the National Fire Protection Association Standard NFPA 58 which requires that:

- Space containing radio equipment shall be isolated by a seal from the space containing the LP-gas container and its fittings.
- Outside filling connections shall be used for the LP-gas container.
- The LP-gas container space shall be vented to the outside of the vehicle.

MOUNTING LOCATION

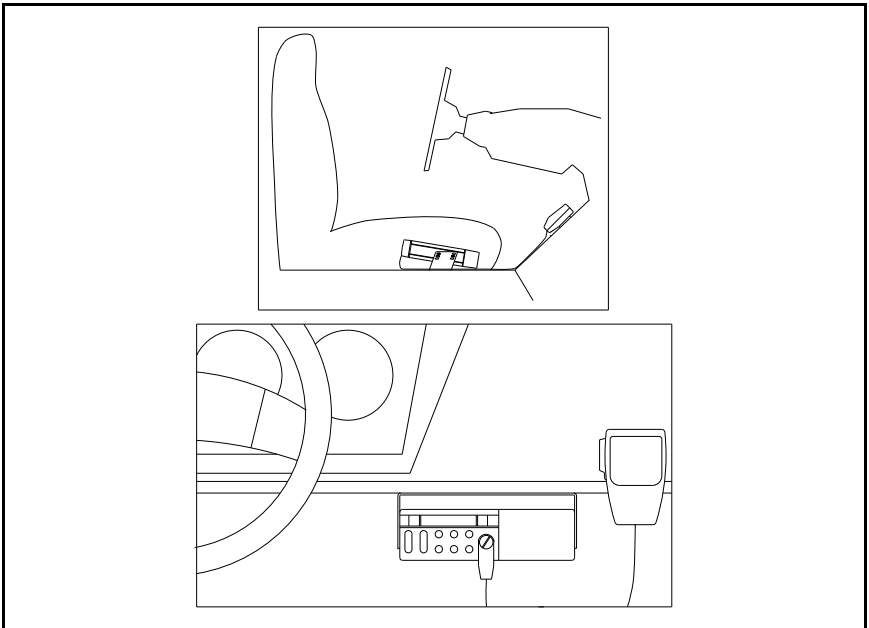

Figure 2 - Typical Hump Or Dash Mount

WARNING

For passenger safety, mount the radio securely so that the unit will not break loose in the event of a collision. This is especially important in station wagons, vans and similar type installations where a loose radio could be extremely dangerous to the vehicle occupants.

INSTALLATION

RUNNING CABLES

To assure the feasibility of the planned cable routings, it is suggested that the cables be run before mounting the radio. Be sure to leave some slack in each cable going to the radio so that the radio may be pulled out for servicing with the power applied and antenna attached.

Try to route the cables away from locations where they will be exposed to heat (exhaust pipes, mufflers, tailpipes, etc.), battery acid, sharp edges, or mechanical damage or where they will be a nuisance to automobile mechanics, the driver, or passengers. Keep wiring away from electronic computer modules, other electronic modules and ignition circuits to help prevent interference to these components and radio equipment.

In addition, try to utilize existing holes in the fire wall and trunk wall and the channels above or beneath the doors. Also, channels through door and window columns that are convenient for running cables may be used, unless planning to install rigid or flexible conduit in which to run the cables.

Power And Ignition Cable

The power cable consists of a red lead, an orange lead, a black lead, a 3 pin systems plug, and a set of fuses and fuse holders to be installed as indicated in Figure 3.

To install the power cable, drill a 5/8 inch hole in the firewall for the cable run and insert the rubber grommet. Starting with the plug end of the cable at the location of the radio, run the three cable leads through the hole. Secure the cable at several locations within the engine compartment.

To install the fuses:

1. Cut off 12 to 18 inches from the red and orange wires.
2. Strip back the insulation approximately 3/8 of an inch on each end of the wires.
3. Lubricate the wire tips with liquid soap to insert the wires into the fuse holders. Pull the wire ends through the small opening at the end of each fuse holder section and crimp a fuse connector to each wire.

4. Push the prepared fuse connectors into each section of the fuse holders. Place the fuse into a fuse holder section until it seats within the connector. Connect the fuse holder sections to insure a tight fit and connection.

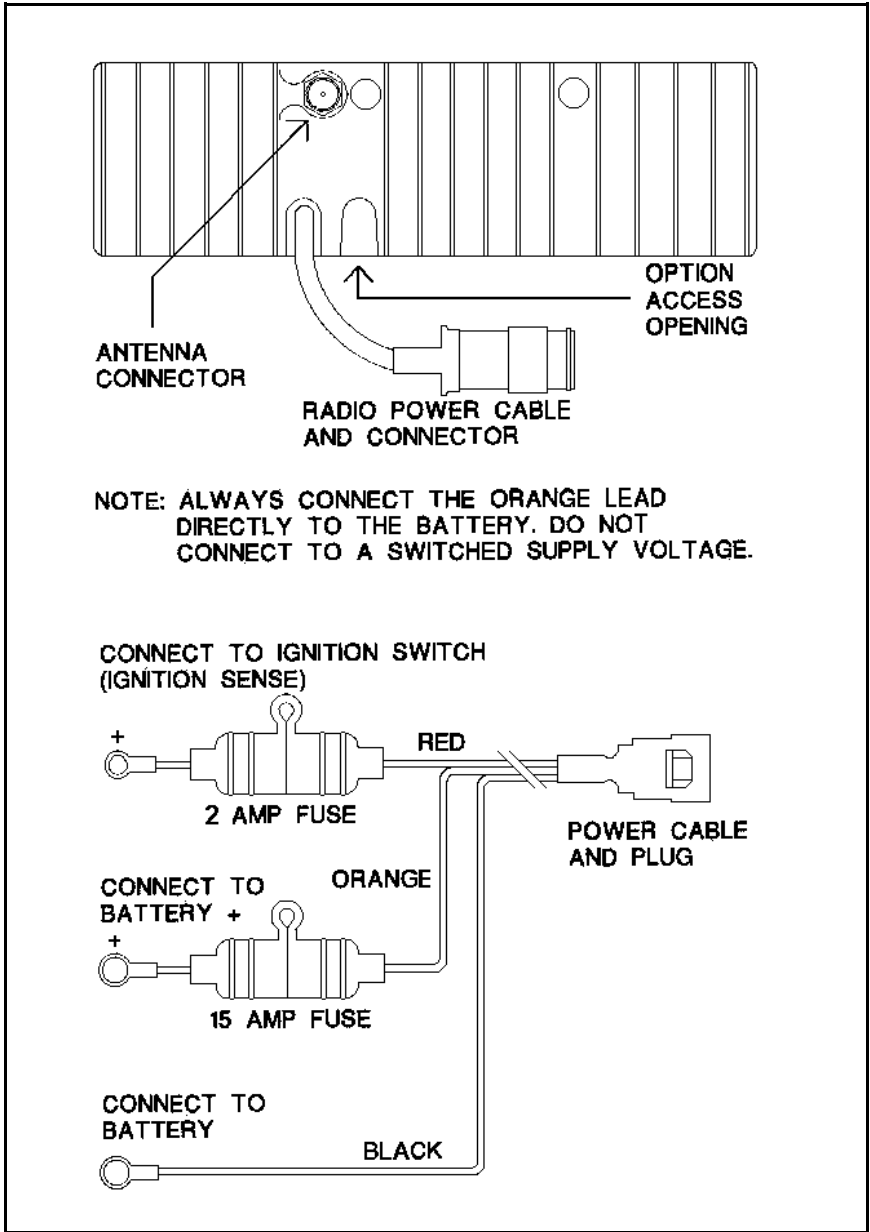

Figure 3 - Power Cable

Connect the orange fused lead to the positive (+) battery terminal, and black to the negative (-) battery terminal. Always locate the fuse as close to the battery as possible.

Connect the red fused lead to the ignition "on" sense point (preferably an "Accessory" point on the fuse panel that is switched on when the ignition switch is in the accessory position and in the "run" position). Locate the fuse as close as possible to the accessory point.

NOTE

With some accessory points, the voltage only drops when the ignition switch is in the START position. A connection point should be used where the voltage is completely off when the ignition switch is in the START position.

NOTE

In some installations an additional noise suppression filter such as option PMPD1A (19A148539G1) may be needed for satisfactory performance.

CAUTION

Certain problems may be encountered when accessory equipment is connected to the ignition or accessory lines of the vehicle, where these lines may have large filter capacitors or a leakage path present.

If the radio does not turn off within a reasonable amount of time after the ignition is turned off, first try a different accessory or ignition sense pickup point in the vehicle. Many vehicles have more than one circuit that is switched by the ignition switch, and one may be available that does not have large filter capacitors or a leakage path present.

If a different pickup point cannot be found, then add a 470-ohm 1-watt resistor from the ignition sense pickup point to ground. This will discharge the capacitor(s) or reduce the leakage voltage to a low value. Current drain through this resistor will be minimal (less than 0.03A) when the ignition is switched on.

Coil any surplus cables and secure them out of the way with the retaining strap provided. Be sure to leave some slack in the cables going to the radio so that it may be pulled out for servicing with power applied.

MOUNTING THE RADIO

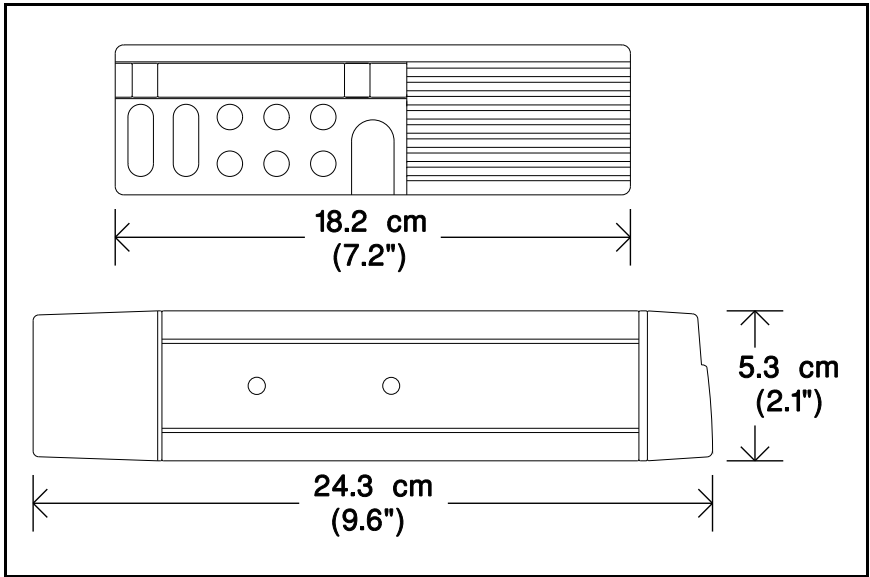
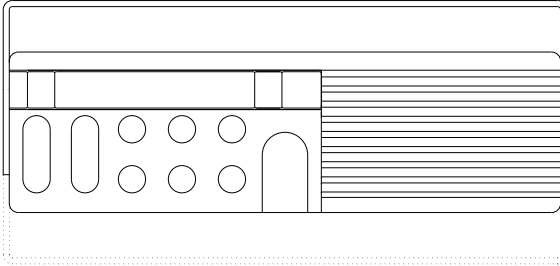

Figure 4 - Mounting Dimensions

Use the supplied mounting bracket as a template to locate the positions for each of the drill holes. Mount the radio as shown in Figure 5. Be sure to leave enough room at the rear of the radio for the cable connections.

TO MOUNT BRACKET, DRILL NO. 24 (9/64 INCH) PILOT HOLES, USE FOUR NO. 10 x 5/8 INCH SCREWS FOR MOUNTING. (USE NO. 10 x 1-1/2 INCH SCREWS IF NEEDED).

THE DOTTED OUTLINES SHOW A SECOND POSITIONING OPTION FOR MOUNTING THE RADIO TO THE TRUNK FLOORBOARD OR FOR HUMP MOUNTING.



RADIO MAY BE TILTED BY USING THE APPROPRIATE HOLES IN THE MOUNTING BRACKET.

ATTACH BRACKET WITH FOUR m4 x 8 mm HEX HEAD SCREWS SUPPLIED. NO. 20 Torx.

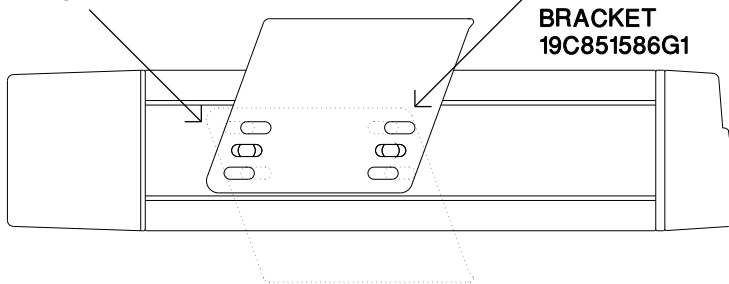

Figure 5 - Mounting Bracket Installation

MICROPHONE HANGER

Mount the microphone hanger in a location convenient to the operator where it will not interfere with the safe operation of the vehicle or be a hazard to the vehicle passengers. The microphone hanger is designed to be mounted with the open end of the mounting button slot pointed upward. The microphone hanger is shown in Figure 6.

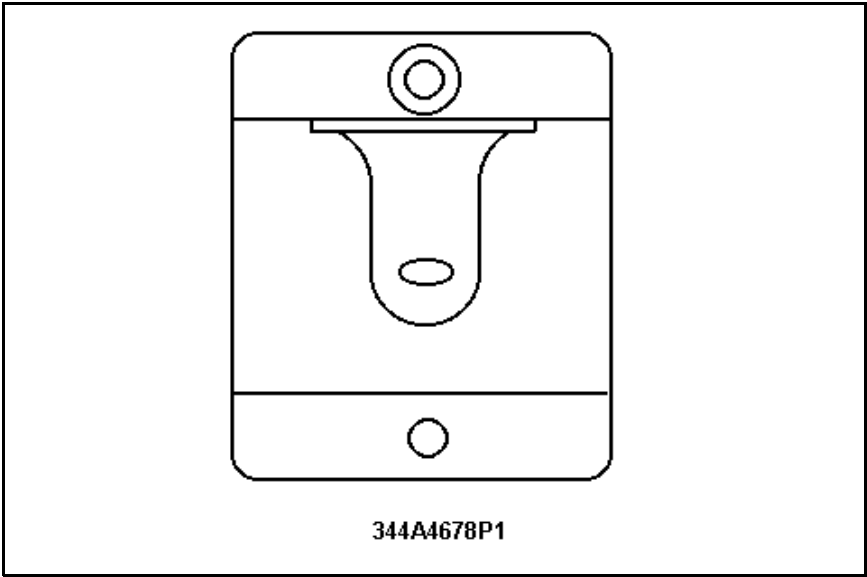

Figure 6 - Microphone Hanger

NOTE

If mounting on a surface covered with carpet, punch holes with a small punch then make a small slit in the carpet, insert a short piece of metal tubing and drill through the tubing.

Use the following procedure to mount the microphone hanger:

1. Use the hanger as a template to mark the screw locations and drill the three small pilot holes.
2. Use the two self tapping screws to mount the hanger in an upright position.

MICROPHONE

The microphone connects to the MDX Mobile Radio using a plug found at the end of its attached cable. Match the pins on this plug to the pin socket on the radio and press in the plug being sure not to damage the pins. Once the plug is seated, tighten down the plug using the thumbscrew on the mic connector. To remove the plug reverse this procedure.



Figure 7 - MDX Mobile Radio With Microphone

MOBILE OPTIONS INSTALLATION

ANTENNA - OPTION PMAN1R

Installation instructions for the antenna are packaged with the antenna. The antenna must be installed in accordance with good engineering practice for optimum results.

A permanent mount type of antenna should be located in the center of the roof or center of rear deck. Glass mounted antennas should be kept as high as possible in the top center of the rear window. Some states have laws restricting vision obstructing items from the windows. Be familiar with local laws before installing glass mount antennas.

Try to route the cable away from locations where it will be exposed to heat, sharp edges or mechanical damage, and where it will be out of the way of the driver, passengers or vehicles mechanics. Wherever possible, existing holes in the trunk wall, and the channels above or beneath doors and window columns should be utilized.

Avoid routing the antenna cable near any electronic modules or along side any vehicle wiring.

Connect the antenna cable to the TNC connector on the radio being careful not to twist the cable.

Option Cable PMCD7Z (19C851585P14)

The Option Cable brings all option connections from the System Board through the back of the radio to the outside. This cable is required with all external options (except the Remote Mount Option). Supplied with the Option Cable is the empty connector housing which plugs into P2 of the Option Cable. Pins supplied on the ends of the wires of each option (Molex #39-00-0060) are inserted into this connector housing. Refer to the Interconnection Diagram in the back of this manual. See Figure 8 for pin locations.

1. Remove the bottom cover of the radio as described previously for Options NPCP1D and NPCP1F.
2. Remove the rubber plug from the slotted opening in the rear of the radio adjacent to the power cable.
3. Plug the Option Cable into J905A on the System Board and push the strain relief on the cable into the slotted opening. Refer to Figure 11.
4. Before replacing the Bottom Cover, Check to see if the particular option being added requires unplugging the internal speaker or changing a jumper (Refer to the section describing the option).

WIRE CONNECTION CHART	
PINS	FUNCTION
P2-1	A-
P2-2	A-/SPEAKER LO
P2-3	SPEAKER HI
P2-4	MIC HI
P2-5	SWITCHED A +
P2-6	GE STAR
P2-7	PTT
P2-8	CG DISABLE
P2-9	SW SPKR HI
P2-10	AUDIO MUTE
P2-11	VOL-SQ HI
P2-12	MIC LO
P2-13	RELAY
P2-14	SPARE

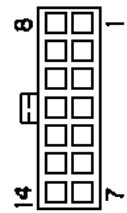
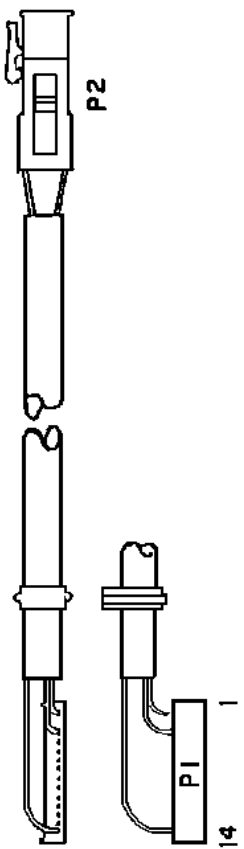

REAR VIEW OF
CONNECTOR HOUSING
(INSERT WIRING THIS SIDE)

Figure 8 - Option Cable Pin Locations

Universal Tone Cable Option PMCC02 (19C851585P19)

The Universal Tone Cable requires the Option Cable (Option PMCD7C). P1 of the Universal Tone Cable plugs into P2 of the Option Cable. The Universal Tone Cable Option provides all option connections on P2 and a 9-pin Winchester connector for connecting to external tone encoders or decoders. See Figure 9

If the tone decoder requires switching the internal speaker, remove the radio bottom cover and cut the PC run between holes 6 and 7 on the System Board.

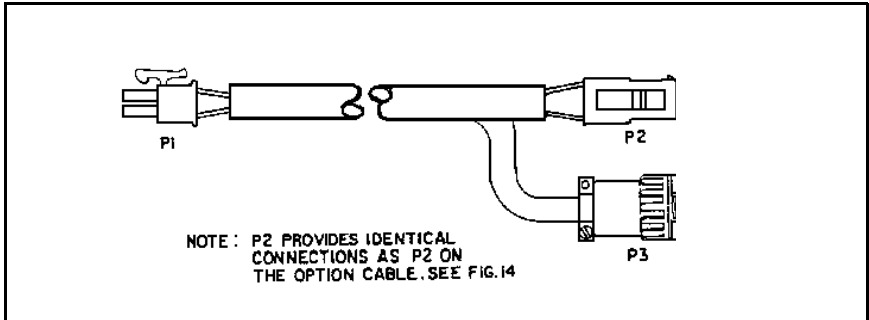

Figure 9 - Tone Cable Pin Location

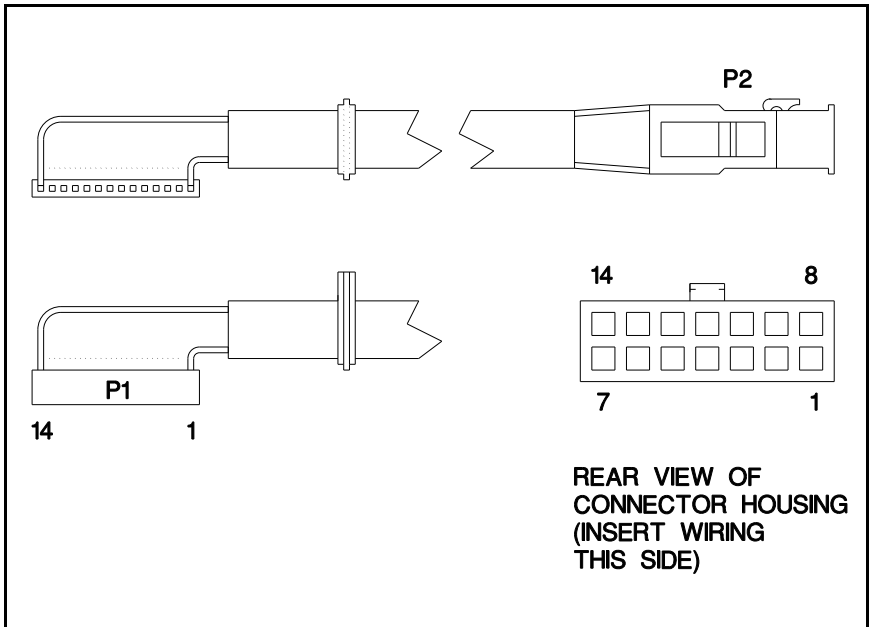

Figure 10- Option Cable Pin Locations

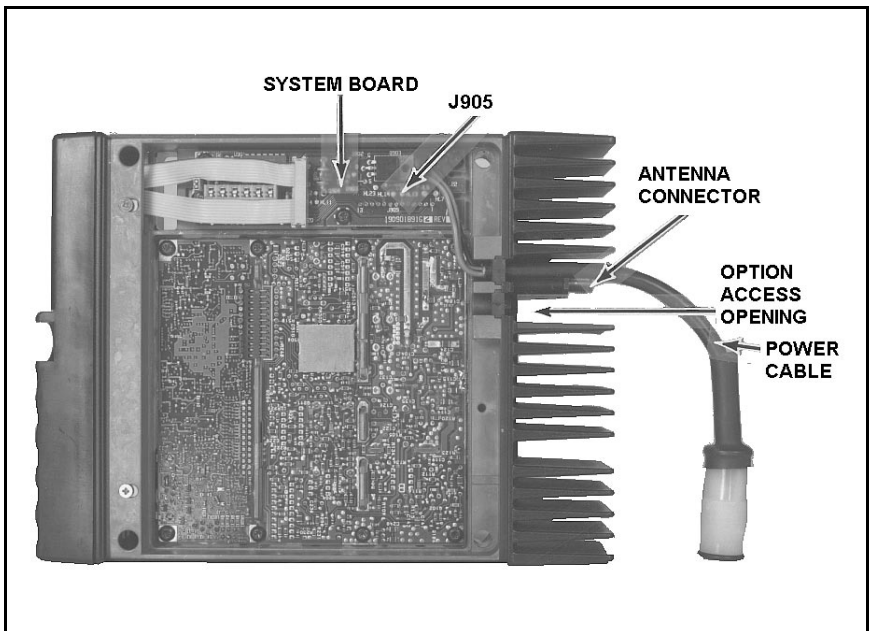

Figure 11 - Bottom View (Cover Removed)

POWER CABLE (18 FEET) - OPTION PMCD9A (19B801358P17)

Refer to the power and ignition cable installation section starting on page 8 to install this optional power cord.

MICROPHONE, MIL SPEC - OPTION PMMC3W (344A4528P55)

Refer to the microphone installation section on page 14 to install this optional microphone.

NOISE SUPPRESSION KIT - OPTION PMPD1A (19A148539G1)

Refer to the noise suppression kit option installation manual that is included with this option and the interconnection diagrams at the back of this manual.

Table 2 - Option Cable Connections

Pins	Function
P2-1	A-
P2-2	SPEAKER LO
P2-3	SPEAKER HI
P2-4	MIC HI
P2-5	SW A+
P2-6	$\overline{\text{SERIAL REQUEST (GE-STAR)}}$
P2-7	$\overline{\text{PTT}}$
P2-8	$\overline{\text{CG DISABLE}}$
P2-9	SW SPEAKER HI
P2-10	$\overline{\text{AUDIO MUTE}}$
P2-11	VOLUME-SQUELCH HI
P2-12	MIC LO
P2-13	$\overline{\text{RELAY}}$
P2-14	SPARE

ALARM (HORN) RELAY KIT - OPTION PMSU1C (19A705499P1)

Requires the use of option cable kit - option PMCC3N. The alarm relay kit option consists of the following items:

- (1) Relay (19A149299P1)
- (1) Fuse holder
- (1) Fuse, 1 amp, 250 volt
- 4 feet red wire, AWG #18 with Ring Tongue Terminal for 3/8 stud
- 6 feet black wire, AWG #18 with Molex #39-00-0060 terminal
- (5) Insulated 1/4 inch spade tab receptacles
- (1) Ring Tongue Terminal for 3/8 inch stud
- (1) #8 x 3/4 long Type A sheet metal screw
- (1) Nut Plate for #8 screw

1. Install the option cable kit - option PMCD7Z in the radio.
2. Fasten the relay in the desired location, close to the voltage source, using one #8 x 3/4 inch self-tapping screw.

3. Crimp an insulated 1/4 inch spade tab receptacle to one end of the #18 red wire. Connect the receptacle to relay lug #86. Cut the red lead so the fuse assembly is close to the voltage source. Install the fuse holder. Attach the other end of the fuse lead to the voltage source with appropriate hardware. See Figure 12.
4. Insert the black wire with the Molex terminal into pin 13 of the option connector housing supplied with the option cable. Plug the connector into the option cable.
5. Crimp an insulated 1/4 inch spade tab receptacle to the other end of the black wire. Connect the receptacle to relay lug #85.
6. Connect the horn or light circuit to lugs #30 and #87 (not 87a) using the insulated 1/4 inch spade tab receptacles.

NOTE

The relay contact make/break current and voltage rating is 30 amps at 16 volts.

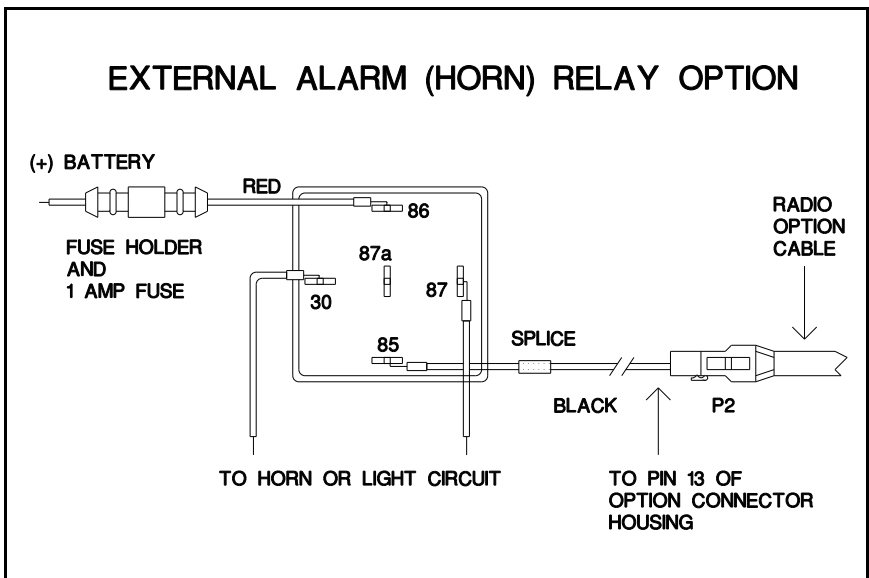

Figure 12 - External Alarm Relay

EXTERNAL SPEAKER KIT - OPTION PMZM1K

The external speaker kit includes a speaker (option PMLS1F) and an external speaker cable (option PMCC9M). External speaker cable (option PMCD1W) is available for use with this kit to place the external speaker up to 16 feet further away from the radio. Installation of this kit requires the option cable kit - option PMD7Z.

1. Mount the speaker so it is directed to the operator but does not cause interference with his vision. It also should not present a hazard in the event of an accident. The speaker may be mounted on the lower edge of the instrument panel, the fire wall, or above the windshield in some trucks. Use the mounting bracket as a template for locating the mounting holes, and mount the speaker as shown in Figure 13.
2. Install the option cable PMCD7Z if not already present.
3. Pins are supplied on the ends of the external speaker cable option PMCC9M. Push these pins into sockets 2 and 9 of the connector housing supplied with the option cable. Refer to Figure 10 and Table 2.
4. Plug the connector housing into P2 of the option cable.
5. Connect the plug end of the external speaker cable to the speaker. If installing the external speaker cable option PMCD1W connect it between the speaker and the plug end of the external speaker cable option PMCC9M.

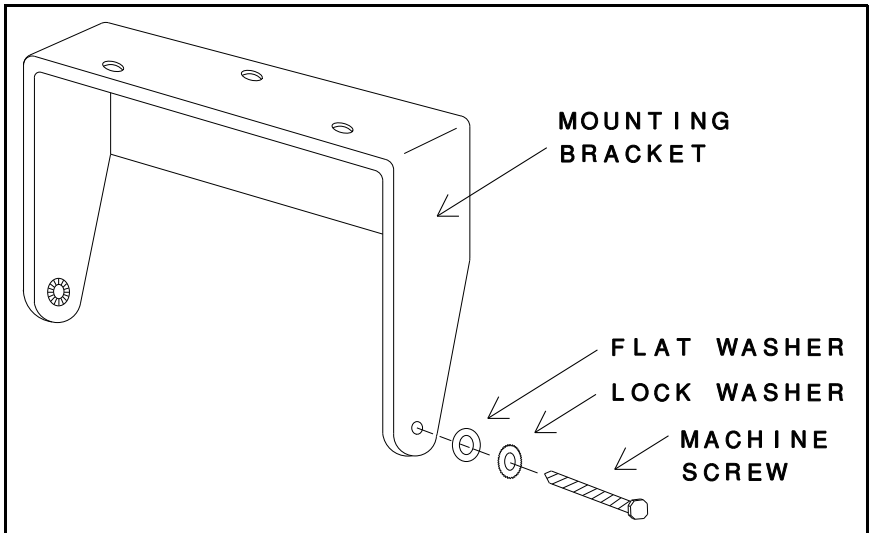

Figure 13 - Mounting The External Speaker

BRAMCO DECODER INSTALLATION NOTES

For proper operation of Bramco decoders with the MDX radio, the following modifications must be made.

Bramco Type 99 Decoder option V8022 (19A149258P11)

On the decode board:

1. Cut one end of R120 (20 ohm, 2W resistor)
2. Remove U5 and replace it with a 74HCN04 or 74HCW4.
3. Install jumper JU1 in B position.

On the switch board install jumpers as follows:

J101 in B position
J102 in A position
J103 in A position

Bramco DTMF Decoder option V8024 (19A149258P10)

On the switch board:

1. Cut one end of R101 (20 ohm 2W resistor)
2. Install jumpers J101 in A position, J102 in A position, J103 in A position.

OPTION INTERCONNECTION DIAGRAM

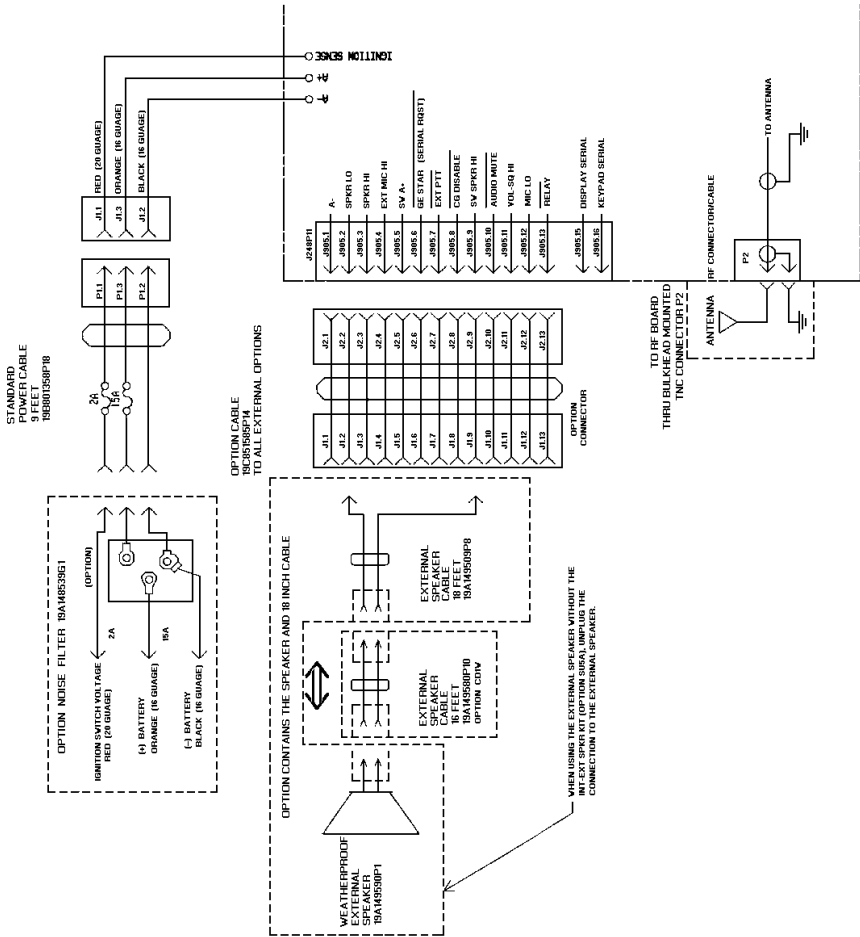

(188D5198, Sh. 1, Rev. 0)

OPTION INTERCONNECTION DIAGRAM

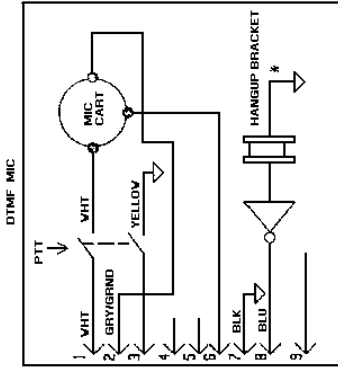

* NOTE: DTMF MIC HANGER MUST BE GROUNDED TO VEHICLE GROUND (NEGATIVE GROUND VEHICLES SYSTEMS).

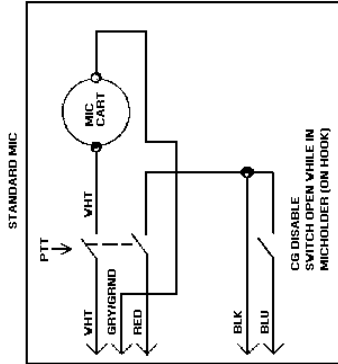

J4456P1
MIC_HI
MIC_LO
PTTFLASH_WPP
DISPLAY SERIAL
KEYPAD SERIAL
SW_A*
A*
CG_DIS/HOOK_SW
HS_RX_AUDIO
J1001.1
J1001.2
J1001.3
J1001.4
J1001.5
J1001.6
J1001.7
J1001.8
J1001.9

MDX
SIMPLEX MOBILE

OPTION INTERCONNECTION DIAGRAM

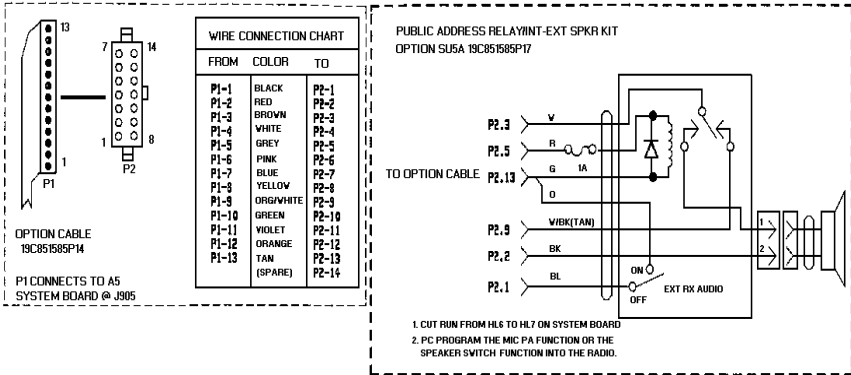

OPTION NUMBER	OPTIONS AVAILABLE	EGE NUMBER
AVR	ANTENNA, UHF / VHF, ROOFTOP TNC	19B202568P6
CD7W	POWER CABLE, 3 FEET	19B301358P18
CD3A	POWER CABLE, 18 FEET	19B301358P17
MCSM,MCSN	STANDARD MICROPHONE	344A4528P1
MCSM,MCSZ	MIL SPEC MICROPHONE	344A4528P55
MH1A	MIC HANGER	344A4528P1
MCSM,MCSA	DTMF MIC	344A4511P1
LSIF,LSH	WATER-PROOF SPEAKER 5" X 5"	19A19598P1
CS3M	EXTERNAL SPEAKER CABLE, 18 INCHES	19A19598P8
CDIV	EXTERNAL SPEAKER CABLE, 16 FEET (REQUIRES CC3M)	19A19598P10
ZMIK,ZMST	SPEAKER KIT (LSIF, CC3M)	—
CD7Z	OPTION CABLE	19C851585P14
PDIA	NOISE SUPPRESSION KIT	19A14853G1
S01C	HOWL ALARM RELAY KIT	19A705439P1
TQ337Z	PC PROGRAMMER CABLE	19B801417P3
TQ3373	PC PROGRAMMING SOFTWARE (EDACS, GEMARC&CONV)	—
TQ3346	PC PROGRAMMING SOFTWARE (GEMARC&CONV)	—
#	MOUNTING BRACKET KIT	19A128051G11
ZM5S	18 FEET REMOTE MOUNT KIT	—
SU5A	PUBLIC ADDRESS RELAY/EXT SPEAKER RELAY KIT	19C851585P17
CY1B	DC REMOTE CONTROL	19A704688P7
TQ3370	PC PROGRAMMING/FLASH INTERFACE BOX	19D438367G2
ZM5R,ZM5U	MIC AND HANGER, MIL SPEC.	—
VS826	QUICK RELEASE SLIDE MOUNT KIT	—

OPTIONS ARE STANDARD

NOTE 1
FOR A COMPLETE LISTING OF OPTIONS SEE YOUR AUTHORIZED EGE DEALER.

OPTION INTERCONNECTION DIAGRAM

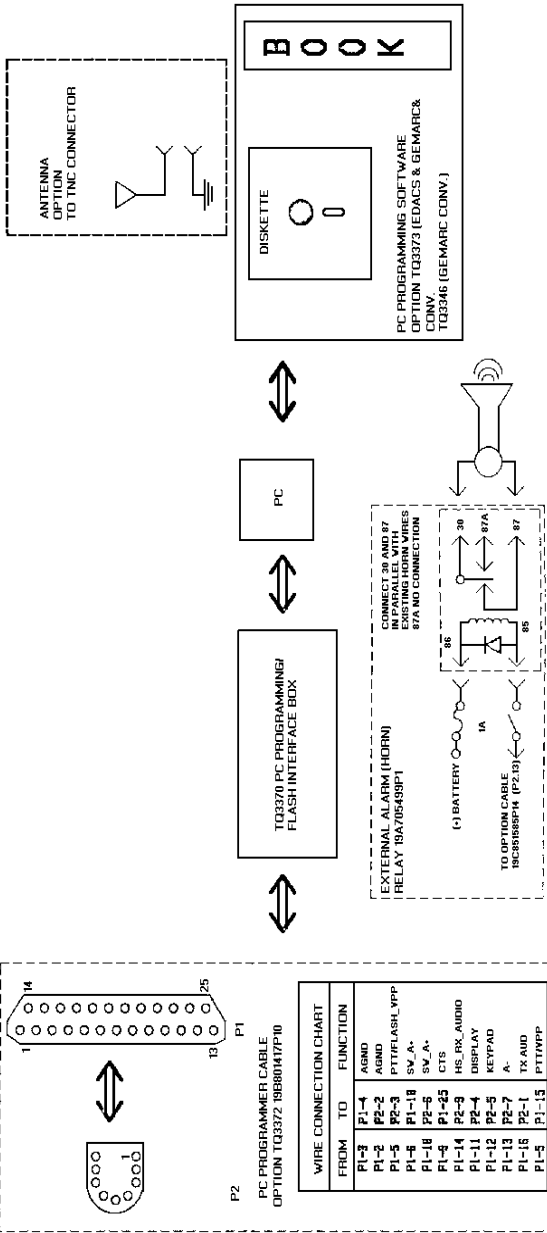

(188D5198, Sh. 3, Rev. 0)

OPTION INTERCONNECTION DIAGRAM

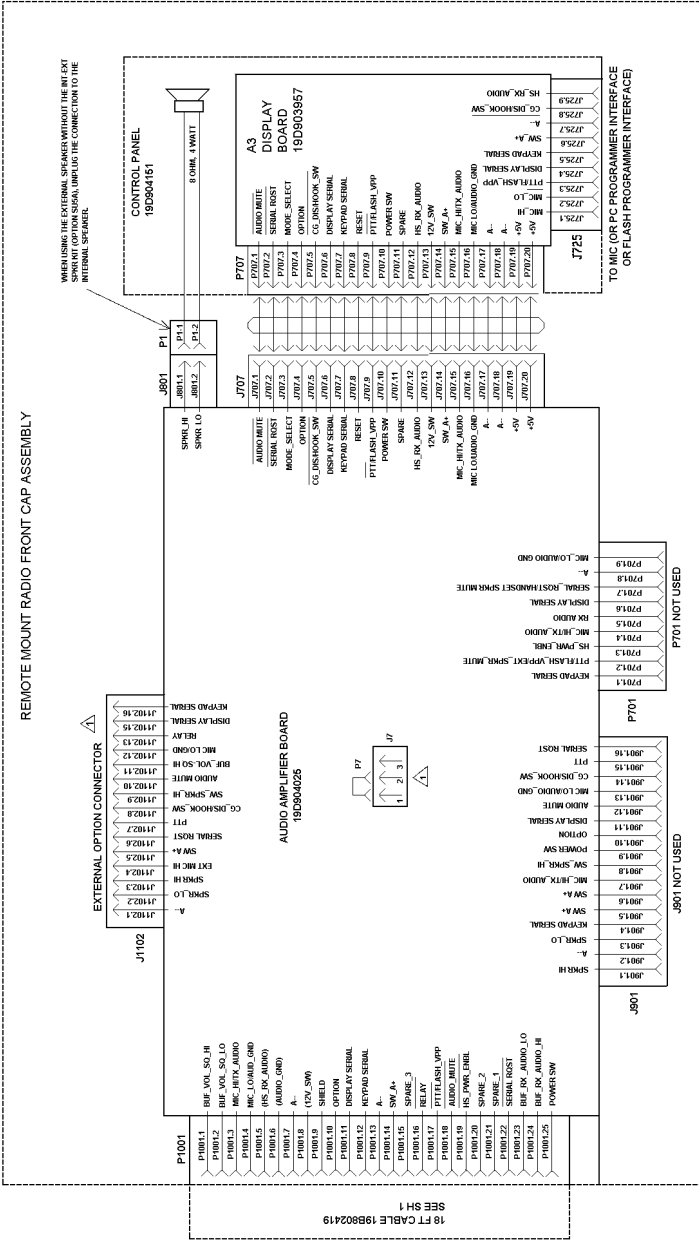



Ericsson GE Mobile Communications Inc.
Mountain View Road • Lynchburg, Virginia 24502