

# Maintenance Manual

MDX™

VHF MOBILE RADIO

## TABLE OF CONTENTS

RF BOARD . . . . .	LBI-39019
SYSTEM BOARD . . . . .	LBI-38842
AUDIO/LOGIC BOARD . . . . .	LBI-39016
AUDIO AMPLIFIER BOARD . . . . .	LBI-38844
FRONT CAP ASSEMBLY . . . . .	LBI-38850
PA BOARD . . . . .	LBI-31921
SERVICE SECTION . . . . .	LBI-39020

**TABLE OF CONTENTS**

	<u>Page</u>
SPECIFICATIONS . . . . .	2
DESCRIPTION . . . . .	3
RF BOARD . . . . .	3
Synthesizer . . . . .	3
Transmitter . . . . .	3
Receiver . . . . .	3
POWER AMPLIFIER BOARD . . . . .	3
AUDIO/LOGIC BOARD . . . . .	3
FRONT CAP ASSEMBLY . . . . .	3
SYSTEM BOARD . . . . .	3
ACCESSORIES AND OPTIONS . . . . .	3
PC PROGRAMMER OPTIONS . . . . .	3
PC PROGRAMMED OPTIONS . . . . .	3
Carrier Control Timer (CCT) . . . . .	3
Channel Guard . . . . .	3
Squelch Tail Elimination (STE) . . . . .	4

**TABLE OF CONTENTS - Cont.**

	<u>Page</u>
HARDWARE AND HARDWARE OPTIONS . . . . .	4
CABLE . . . . .	4
NOISE SUPPRESSION KIT . . . . .	4
POWER CABLE . . . . .	4
EXTERNAL SPEAKER . . . . .	4
EXTERNAL ALARM . . . . .	4
RADIO OPERATION . . . . .	4
USER INTERFACE . . . . .	4
PUBLIC ADDRESS OPTION OPERATION . . . . .	7
TYPE 99 OPTION OPERATION . . . . .	8
PARTS LIST . . . . .	10
ASSEMBLY DIAGRAM . . . . .	10
INTERCONNECTION DIAGRAM . . . . .	13

**NOTICE!**

This manual covers Ericsson and General Electric products manufactured and sold by Ericsson Inc.

**NOTICE!**

Repairs to this equipment should be made only by an authorized service technician or facility designated by the supplier. Any repairs, alterations or substitution of recommended parts made by the user to this equipment not approved by the manufacturer could void the user's authority to operate the equipment in addition to the manufacturer's warranty.

**NOTICE!**

The software contained in this device is copyrighted by the Ericsson Inc. Unpublished rights are reserved under the copyright laws of the United States.

This manual is published by **Ericsson Inc.**, without any warranty. Improvements and changes to this manual necessitated by typographical errors, inaccuracies of current information, or improvements to programs and/or equipment, may be made by **Ericsson Inc.**, at any time and without notice. Such changes will be incorporated into new editions of this manual. No part of this manual may be reproduced or transmitted in any form or by any means, electronic or mechanical, including photocopying and recording, for any purpose, without the express written permission of **Ericsson Inc.**

**SPECIFICATIONS\***

**GENERAL**

	<u>FCC</u>	<u>DOC</u>
Regulatory Approval	AXATR-328-B2 (150-175 MHz)	TR-328
	AXATR-328-A2 (136-153 MHz)	TR-328
Operating Voltage	13.8 Volts *20%	
Battery Drain		
Receiver (13.8 Vdc)		
Off	0.01 Amperes (Maximum)	
Squelched	0.75 Amperes (Maximum)	
Unsquelched	3.5 Amperes (Maximum at 10 Watts audio, External Speaker)	
Transmitter (13.8 Vdc)	10.5 Amperes (Maximum at 40 Watts RF)	
Channel Spacing	25/30 kHz (6.25 or 5 kHz resolution)	
Frequency Stability	± 2.5 PPM (± 0.00025%)	
Temperature Range	-30°C to 60°C (-22°F to +140°F)	
Dimensions (H X W X D)		
(Less Accessories)		
Height	5.3 cm (2.1 inches)	
Width	18.2 cm (7.2 inches)	
Depth	24.0 cm (9.5 inches)	
Weight	3.0 kg (6.6 pounds)	
Antenna Impedance	50 Ohms	
<b>TRANSMITTER</b>		
Frequency Range		
Low Split Radio	136.0 to 153.0 MHz	
High Split Radio	150.0 to 174.0 MHz	
Output Power	40 Watts (Intermittent duty cycle; EIA 20%)	

**SPECIFICATIONS\* - Cont.**

Audio Sensitivity	110 mV RMS (typical)
Spurious and Harmonics	Less than -16 dBm
Audio Distortion	5% maximum
Modulation Limiting	±5 kHz (Maximum)
FM Hum and Noise	-45 dB
Audio Frequency Response	Within +1, -3 dB of a 6 dB/octave pre-emphasis curve from 300-3000 Hz

**RECEIVER**

Frequency Range	
Low Split Radio	136.0 to 153.0 MHz
High Split Radio	150.0 to 174.0 MHz
Acceptable Frequency Displacement	± 2.5 kHz minimum
Sensitivity (12 dB SINAD)	-116 dBm maximum
Spurious Rejection	-80 dB maximum
Image Rejection	-70 dB maximum
Adjacent Channel Selectivity	-80 dB maximum at ± 30.0 kHz
Intermodulation Distortion	-75 dB maximum
Audio Frequency Response	Within +1/ -3 dB from 500 Hz to 2500 Hz, 6 dB/octave attenuation from 300-500 Hz, 12 dB/octave attenuation from 2500-3000 Hz (per EIA/TIA-603)
Audio Output	10 Watts (External Speaker); 4 Watts (Internal Speaker) 7.5 Watts (External Speaker with remote mount kit)
Audio Distortion	5% maximum at 1 kHz
Hum and Noise	-45 dB maximum

**ENVIRONMENTAL**

STANDARD	METHODS PROCEDURES		
	Mil-810C	Mil-810D	Mil-810E
High Temperature	501.1/Proc 2	501.2/Proc 2	501.3/Proc 2
Low Temperature	502.1/Proc 2	502.2/Proc 2	502.3/Proc 2
Low Pressure	500.1/Proc 1	500.2/Proc 1	500.3/Proc 1, 2
Solar Radiation	505.1/Proc 1	505.2/Proc 1	505.3/Proc 1
Temperature Shock	503.1/Proc 2	503.2/Proc 1	503.3/Proc 1
Vibration	514.2/C8, P1	514.3/Proc 8	514.4/C8, P1

Continued

Continued

STANDARD	METHODS PROCEDURES		
Mechanical Shock	516.2/Proc 1	516.3/Proc 1-6	516.4/Proc 1-6
Humidity	507.1	507.2	507.3
Salt Fog	509.1/Proc 1	509.2/Proc 1	509.3/Proc 1
Blowing Dust	510.1/Proc 1	510.2/Proc 1	510.3/Proc 1
Driven Rain	506.1/Proc 1	506.2/Proc 1	506.3/Proc 1

**U.S. Forest Service**

Vibration: Methods 7.15.1 and 8.11.1

**EIA**

Vibration: RS152B Method 14.3 and RS206C Method 24.2  
Shock: RS152B Method 15 and RS204C Method 25

\* These specifications are intended primarily for use by a service technician. Refer to the appropriate Specification Sheet for complete specifications.

## DESCRIPTION

The VHF MDX™ Mobile Radio is a synthesized, wide band radio that uses integrated circuits and microcomputer technology to provide high performance in conventional communications systems. The VHF MDX Mobile radio provides 40 Watts of RF power output in the 136-153 MHz or 150-174 MHz bands.

This radio operates in the conventional mode and can operate with tone Channel Guard, Digital Channel Guard, or carrier squelch, depending on personality programming. The Channel Guard range is 67.0 to 210.7 Hz. Squelch Tail Elimination (STE) is used with Channel Guard to eliminate squelch tails at the receiving radio by phase shifting the transmitted Channel Guard tone when the Push-To-Talk (PTT) switch is released.

All radio functions are stored in a programmable Electrically Erasable PROM (EEPROM).

- Serial Programming Interface Module TQ3370
- Programming Cable (19B801417P10) TQ3372
- MDX Series Programming Software TQ3346

With the interface equipment and software, the computer can be used to program (or re-program) customer system frequencies, Channel Guard tones and options. Selection of options is done during radio initialization using the PC programmer.

The VHF MDX Mobile Radio assembly contains the following circuit boards and assemblies:

- Power Amplifier 19C851540
- RF Board 19D904958
- System Board 19D901891
- Audio/Logic Board 19D903963
- Audio Amplifier Board 19D904025
- Front Cap Assembly 19D904151

The circuit boards are all mounted on a main casting to provide easy access for servicing. Interconnect plugs are used to connect the boards to eliminate pinched wires and other wiring problems.

## RF BOARD

The RF Board includes the programmable frequency synthesizer, transmitter exciter, receiver front-end and Intermediate Frequency (IF) circuitry.

## Synthesizer

The synthesizer circuit generates all transmit and receive RF frequencies. The synthesizer frequency is controlled by the microprocessor located on the Audio/Logic Board. Frequency stability is maintained by a temperature compensated reference oscillator module. Transmit audio is processed on the Audio/Logic Board and applied to the synthesizer to modulate the Voltage Controlled Oscillator (VCO) and the Temperature Controlled Xtal (crystal) Oscillator (TCXO). The buffered VCO output drives both the transmitter exciter and the receiver mixer.

## Transmitter

The transmitter consists of a fixed-tuned exciter module, PA module and a power control circuit. The PA module provides RF output to drive the antenna. The power control circuit controls the PA module to maintain constant output power across the band. The RF output level is internally adjustable for rated power. A thermistor control circuit protects the PA from overheating by linearly reducing the power output level with increasing temperature.

## Receiver

The dual conversion receiver circuit consists of a front-end section, 45 MHz first IF, a 455 kHz second IF and Frequency Modulation (FM) detector. All audio processing and squelch functions are accomplished on the Audio/Logic Board.

## POWER AMPLIFIER BOARD

The PA Board amplifies the RF board output, then connects it back to the RF board where it is coupled through a PIN diode antenna switch, a low-pass filter and a directional coupler to provide 40 watts power output at the antenna connector.

## AUDIO/LOGIC BOARD

The Audio/Logic Board provides all audio and digital processing of the receive and transmit audio for digital processing by the Logic Board. This board also contains audio filtering, conventional analog tone processing and the receiver squelch. The Audio/Logic Board controls the operation of the radio and digitally processes the receiver and transmit audio. The board contains a microprocessor and associated memory circuits including an Electrically Programmable Read Only Memory (EPROM) for controlling the processor and a programmable "personality" memory, an EEPROM to store customer frequencies, tones and options. The microprocessor provides control data to the Audio Signal Processor (ASP) conventional tone generation and detection, frequency data for the synthe-

sizer and sends and receives data to/from another microprocessor on the Display Board for the alphanumeric LED display.

## SYSTEM BOARD

The system board controls the main input power to the radio. The IGNITION SENSE input lead provides the necessary signals to the MOSFET switching circuit. The board also interfaces all option connections from the internal boards in the radio with the optional items outside of the radio. All external options for the radio, interconnect to the System Board through the back of the radio using an optional cable.

## FRONT CAP ASSEMBLY

The Front Cap Assembly contains the Audio Amplifier Board. This board provides audio compression for the received audio in the discriminator internal/external speaker audio paths. A 10-watt power amplifier is provided on the board to drive a 4-ohm external speaker or the 8-ohm internal speaker.

## ACCESSORIES AND OPTIONS

### PC PROGRAMMER OPTIONS

The radio is programmed using an IBM compatible Personal Computer (PC) equipped with an RS-232 serial interface unit and the cable between the PC and the unit. An auxiliary power supply for the unit is also included but is not needed to program the radio.

Option TQ3372 provides the MDX VHF radio programming cable between the PC interface unit and the radio microphone jack.

### PC PROGRAMMED OPTIONS

#### Carrier Control Timer (CCT)

The Carrier Control Timer turns off the transmitter after the microphone PTT switch has been keyed for a pre-programmed time period. A pulsing alert tone warns the operator to unkey and then key again the PTT to continue the transmission. The timer can be programmed, using the PC programmer. Any time period between 0 seconds and 4.1 minutes can be programmed in 10 second increments. The timer can be enabled or disabled for each channel.

#### Channel Guard

Channel Guard provides a means of restricting calls to specified radios through the use of a Continuous Tone Coded Squelch System (CTCSS), or a Continuous Digital Coded Squelch System (CDCSS). Tone frequencies range from 67.0 Hz to 210.7 Hz in 0.1 Hz steps. There are 83 standard PC programmable digital codes. The Channel Guard tone frequencies and codes are software programmable. Both tone frequencies and digital codes may be used. These codes and frequencies are listed in Table 1- Channel Guard Tone Frequencies and Table 2- Digital Channel Guard Codes.

#### NOTE

To reverse the polarity of the digital Channel Guard codes, in the PC programmer, type i (inverted) before the code number, i.e. i023.)

Table 1 - Standard Tone Frequencies (Hz)

67.0	71.9	74.4	77.0	79.7	82.5	85.4	88.5	91.5	94.8	97.4
100.0	103.5	107.2	110.9	114.8	118.8	123.0	127.3	131.8	136.5	141.3
146.2	151.4	156.7	162.2	167.9	173.8	179.9	186.2	192.8	203.5	210.7
1. Do not use 179.9 Hz or 118.8 Hz in areas served by 60 Hz power distribution systems (or 100.0 Hz or 151.4 Hz in areas supplied with 50Hz power). Hum modulation of co-channel stations may "false" Channel Guard decoders. 2. Do not use adjacent Channel Guard tone frequencies in systems employing multiple Channel Guard tones. Avoid same-areas co-channel use of adjacent Channel Guard tones whenever possible. As stated in EIA Standard RS-220, there is a possibility of decoder falsing. 3. To minimize receiver turn-on time delay, especially in system using Channel Guard repeaters or receiver voting, choose the highest usable Channel Guard tone frequency. Do not use tones below 100 Hz when it is necessary to meet the receiver response time requirements of EIA Standard RS-220.										

Table 2 - Digital Channel Guard Codes

PRIMARY CODE	EQUIVALENT CODE	PRIMARY CODE	EQUIVALENT CODE	PRIMARY CODE	EQUIVALENT CODE
023	340 766	251	236 704 742	632	123 657
025		261	227 567	565	307 362
026	566	263	213 736	654	163 460 607
031	374 643	265	171 426	662	363 436 443 444
032		271	427 510 762	664	344 471 715
043	355	306	147 303 761	703	150 256
047	375 707	311	330 456 561	712	136 502
051	520 771	315	321 673	723	235 611 671
054	405 675	331	372 507	731	447 473 474 744
065	301	343	324 570	732	164 207
071	603 717 746	346	616 635 724	734	066
072	470 701	351	353 435	743	312 515 663
073	640	364	130 641	754	076 203
074	360 721	365	107	<b>036</b>	137
114	327 615	371	217 453 530	<b>053</b>	
115	534 674	411	117 756	<b>122</b>	535
116	060 737	412	127 441 711	<b>145</b>	525
125	173	413	133 620	<b>212</b>	253
131	572 702	423	234 563 621 713	<b>225</b>	536
132	605 634 714	431	262 316 730	<b>246</b>	542 653
134	273	432	276 326	<b>252</b>	661
143	333	445	222 457 575	<b>255</b>	425
152	366 415	464	237 642 772	<b>266</b>	655
155	233 660	465	056 656	<b>274</b>	652
156	517 741	466	144 666	<b>325</b>	550 626
162	416 553	503	157 322	<b>332</b>	433 552
165	354	506	224 313 574	<b>356</b>	521
172	057	516	067 720	<b>446</b>	467 511 672
174	142 270	532	161 345	<b>452</b>	524 765
205	135 610	546	317 614 751	<b>454</b>	513 545 564
223	350 475 750	606	153 630	<b>455</b>	533 551
226	104 557	612	254 314 706	<b>462</b>	472 623 725
243	267 342	624	075 501	<b>523</b>	647 726
244	176 417	627	037 560	<b>526</b>	562 645
245	370 554	631	231 504 636 745		

NOTE:  
Primary codes in bold are unique Ericsson codes.

**Squelch Tail Elimination (STE)**

STE is used with tone and digital Channel Guard to eliminate squelch tails. The STE burst is transmitted when the microphone PTT switch is released. The receiving radio decodes the burst and mutes the receiver audio for 250 ms. This mute time allows the transmission to end and to mute the squelch tail. The radio looks for STE on the received signal when the microphone is either on or off-hook.

**HARDWARE AND HARDWARE OPTIONS**

The location and placement of system hardware options is shown on MDX Conventional Mobile Radio Interconnection Diagram 188D5198.

**CABLE OPTION PMCD7ZE**

Cable Option PMCD7Z (19D851585P14) is used to bring all option connections from the system Board through the back of the radio to the outside. This cable is required with all external options.

**NOISE SUPPRESSION KIT OPTION PMPD1A**

Noise Suppression Kit, Option PMPD1A, consist of filter 19A148539G1 and Installation Manual LBI-31363. This kit is available for installations where excessive alternator or electrical noises, present on the power cable, do not permit the radio to operate properly. Refer to the Interconnect Diagram for the radio and options.

**POWER CABLE OPTION PMCD9A**

The 18-foot Power Cable Option, PMCD9A (19B801358P17) is available for installations requiring more than the standard 9-foot cable.

**EXTERNAL SPEAKER OPTION PMZM1T**

External Speaker and Cable Option PMZM1T, provides the user a 5-inch waterproof speaker in a LEXAN housing. Option PMCC9M is an 18-inch interconnecting cable for the speaker. The 10-Watt amplifier drives the speaker 4-ohm impedance. The speaker leads are connected to Pins 2 and 9 of Cable option PMCD7Z (19D851585P14), using 18-inch external speaker cable option PMCC9M (19A149590P8), included in the option PMCD7Z. A 16-foot cable option PMCD1W (19A149590) is also available.

When using the external speaker, the internal speaker should be disconnected. The internal/external speaker switch option PMPL3D allows use of both speakers (Refer to the Interconnection Diagram 188D5198).

**EXTERNAL ALARM HORN RELAY OPTION PMSU1C**

External Alarm Horn Relay Option PMSU1C (19A705499P1) can sound the vehicle horn when a call is received. The option connects to Pin 13 of cable option PMCD7Z (19C851585P14) and is enabled through the front panel switch.

**RADIO OPERATION**

A complete set of operating instructions for the MDX VHF radio are provided in Operator's Manual LBI-39012. A copy of LBI-39012 is provided with each radio.

In the conventional mode of operation, the user selects a channel and communicates on that channel in the conventional mode. A system refers to a set of channels and a channel is a transmit/receive radio frequency pair.

The exact operation of any radio depends upon the operating mode, the programming of the radio and the particular radio system. Most features described in these operating instructions can be enabled or disabled through programming. Both of these important factors must be considered when addressing the following instructions.

**USER INTERFACE**

Operating controls are located on the radio front panel and microphone.

The Front panel Light Emitting Diode (LED) display provides radio status and communication control information for the operator. The keypad is used for activation of various features and functions.

**Turning The Radio On/Off**

The radio is turned On/Off by pressing the PWR button in the upper left corner of the front panel. To turn the radio OFF press the PWR button again.

**SCAN OPERATION**

The SCAN function allow monitoring up to 16 receive channels. The scanned channels may be any frequency within the frequency band limits of the radio and may be Channel Guard protected (tone/digital). All scan functions are retained in memory, even if the 12 Volt battery is disconnected.

Any channel may be scanned with or without a priority level. One channel may be programmed for Priority 1 (P1) and another for Priority 2 (P2) with any or all remaining channels programmed as non-priorities.

**RECEIVER SCAN RATE**

The scan rate for the radio will vary depending upon the number of channels programmed into the scan list and whether or not Channel Guard is programmed. When scanning 16 inactive channels, the priority channels are sampled 11 times/second and the non-priority channels 3 times/second. The scan rate will be faster when fewer channels are programmed into can memory.

Scan operation will be determined by the following conditions:

- **PRIORITY 1, PRIORITY 2 AND NON-PRIORITY PROGRAMMED**

The Priority 1, Priority 2 and up to 14 remaining channels will be scanned. Once a carrier is detected and if programmed, the correct Channel Guard is decoded, the LED display will indicate that channel. Sampling of the Priority 1 and Priority 2 channels continues while receiving a message. Should a Priority 1 or 2 channel carrier with the correct Channel Guard be detected while a non-priority channel is being received, the applicable indicator, P1 or P2 lights and the channel is switched to the Priority 1 or 2 channel regardless of what is being received on the non-priority channel.

- **NON-PRIORITY PROGRAMMED**

Up to 16 non-priority channels may be scanned. Once a carrier is detected or correct Channel Guard is decoded, the digital display will indicate the channel. Scan will stop and remain on the channel until the carrier disappears; after a few seconds scanning resumes. The channels are scanned in descending order.

## TO PROGRAM SCAN CHANNELS AND SELECT PRIORITY

The selection of scan channels and priority is front panel programmable the programmed flex key or menu mode.

**NOTE**

The following, details how to add/delete channels using the flex key mapped to scan add/delete. The alternative is to select "SCAN A/D" in the menu mode. Select the desired channel using the "-" button and add/delete channels using the "+" button.

- **NON-PRIORITY (S)**

1. Confirm that the radio is turned on. If not, press the **POWER** switch.
2. If the **SCAN** indicator is lit, press and release the **SCAN** switch to disable the scan function.
3. Select the desired channel using the **CHANNEL UP** and **DOWN** switch.

4. Press the programmed flex key, mapped to scan add/delete, to add the channel to the scan list. The **S** indicator will be shown in the display to indicate that the channel is now in the scan program.
5. Repeat steps 2 through 4 for each channel, up to 16, to be added to the scan list.

- **PRIORITY 2 (P2)**

1. With scan off, select the desired **P2** channel.
2. Press the programmed flex key, mapped to scan add/delete, twice. The displayed channel will now become the Priority 2 channel and the P2 indicator will light to indicate that the channel is now in the scan list as priority 2.

**NOTE**

A previous channel with priority will become a non-priority scan channel when a new priority channel is programmed.

- **PRIORITY 1 (P1)**

The Priority 1 channel may be added to the scan list by one of three methods by PC programming the radio personality. Normally **P1** is added using the front control panel (**Method 1**).

- **Method 1: FRONT PROGRAMMABLE**

1. With scan off, select the desired P1 channel.
2. Press the programmed flex key, mapped to scan add/delete, three times. The displayed channel will now become the Priority 1 channel and the **P1** indicator will light to indicate that the channel is now in the scan list as priority 1.

- **Method 2: FIXED P1 OPTION**

The **P1** channel is PC programmed into the radio personality.

- **Method 3: SELECTED CHANNEL OPTION**

This option is PC programmed into the radio personality. Each time the scan function is turned on by pushing the **SCAN** switch, the **P1** channel becomes the channel in the display (the **SELECTED** channel).

## DELETE SCAN CHANNEL (S, P1, P2)

1. Confirm that the radio is on. If not, press the power switch.
2. If **SCN** indicator is lit, press and release the **SCAN** switch to disable scan function.
3. Select the desired channel to be removed from the scan list using the **CHANNEL UP** or **DOWN** switches.
4. Press the programmed flex key, mapped to scan add/delete, until all scan indicators (**S**, **P1** and **P2**) are off. This removes the selected channel from the scan list.
5. Repeat preceding steps 2 through 4 for each channel to be removed from the scan list.

## REVIEWING THE SCAN LIST

1. Confirm that the radio is turned on. If not, press the **POWER** switch.
2. If the **SCAN** indicator is lit, press and release the **SCAN** switch to disable the scan function.
3. Select each channel (one at a time) using the **CHANNEL UP** or **DOWN** switch and confirm channels included on the scan list. The scan indicators (**S**, **P1**, **P2**) will light for each channel programmed.

## USING THE RADIO WITH SCAN

### THE SELECTED CHANNEL

The **SELECTED** channel is the channel in the display when scan is turned on by pushing the **SCAN** switch. When a signal is not being received, the radio reverts to this channel for transmitting. When a signal is being received, the radio reverts to this channel for transmitting. When a signal is being received, the radio can be PC programmed to either revert to the **SELECTED** channel or remain on the received channel.

The **SELECTED** channel does not necessarily have to be a channel in the scan list. The **SELECTED** channel will be temporarily entered into the scan list and scanned until the **SELECTED** channel is changed.

When scan is turned off by pushing the **SCAN** switch, the radio will return to the **SELECTED** channel.

## DISPLAY

### Channel Indicator

While no signal is being received, the channel indicator will always show the **SELECTED** channel. When an active channel is received, the channel indicator will show the received channel.

### SCN Indicator

When the **SCAN** button is pushed, the radio will light the **SCAN** indicator and begin scanning. The **SCN** indicator will flash when the microphone is placed off-hook to show the radio is no longer scanning (only if the radio is PC programmed not to scan off-hook).

## TRANSMITTING WHILE IN SCAN

Transmitter operation in scan is determined by the PC programming of the radio personality. A flow chart is provided in this section to summarize the scan operation the following description.

### Off-Hook Scan Not Enabled (default):

With off-hook scan not enabled (normal default condition), all scanning will stop when the microphone is placed off-hook. The **SCN** indicator will flash to show all scanning has stopped. If a signal is not being received when the microphone is placed off-hook, the radio will transmit on the **SELECTED** channel. If a signal is being received when the microphone is placed off-hook, the radio can be PC programmed (using the "scan transmit option" to either stay on the receive channel or revert to the **SELECTED** channel. When the microphone is placed back on-hook, the radio will immediately start scanning, even if the received channel was still active.

### Off Hook Scan Enabled:

With off-hook scan enabled, moving the microphone off-hook will not affect scan operation. The radio will continue scanning. If a signal is not being received, the radio will transmit on the **SELECT** channel. If a signal is being received, the radio can be PC programmed (using the "scan transmit channel" option) to either stay on the receive channel or revert to the **SELECTED** channel when the microphone PTT is keyed.

## MONITOR (CLR) SWITCH OPERATION IN SCAN

The CLR switch does not operate while scanning inactive channels. When a channel becomes active, the CLR switch operates only during the scan hang time after the channel activity disappears.

## CHANNEL CHANGES IN SCAN

Pushing the channel switches (UP or DOWN) while scan is turned on will change the SELECTED channel assignment. If a signal is being received and the channel switches are pushed, the radio will revert to the new SELECTED channel assignment. The channel indicator display will show the new assignment. After 2 seconds, if no activity appears on the new SELECTED channel, scanning will resume. If the SELECTED Channel is changed to a channel not in the scan list, the new channel will be temporarily added to the scan list until the SELECTED channel is changed again.

### Temporary Channel Deletions:

The SCAN function must be turned off to make any permanent changes (additions, deletions, priorities) to the scan list. While in scan, temporary channel deletions may be made to the scan list. The original scan list will be back in effect by either turning scan off (by pushing the SCAN switch) or by turning the radio power off and back on.

When the radio stops scanning on an active channel, the channel may be temporarily deleted by pressing the programmed flex key mapped to scan add/delete. The radio will immediately resume scanning while skipping over the temporarily deleted channel.

Temporary deletions cannot be made until the radio stops on an active channel. P1 and P2 channels cannot be temporarily deleted.

## PC PROGRAMMING SCAN OPTIONS

### 1. Scan Hang Time:

A scan hang time is applied after the carrier on an active channel disappears and after releasing the transmitter PTT. The hang time prevents momentary signal fades from resuming scan (which would cause big gaps in the receive audio) and allows time to respond to a received call. The hang time also prevents the radio from immediately leaving the channel and resuming scan when the PTT is released to allow time for a return call. The scan hang time is normally 2 seconds in length and PC programmed.

programmable from 0.3 to 5 seconds on 0.1 seconds steps. If no other channel activity occurs during this time, scanning will then resume. The priority channels are still being sampled during the hang time.

### 2. Hang Time After PTT Release:

**YES** (default): If off-hook scan is enabled, after the PTT is released, the radio will not stay on channel but will immediately resume scanning. The scan hang time will still be applied after a received carrier disappears.

**NO**: If off-hook scan is enabled, when the PTT is released, the radio will not stay on channel but will immediately resume scanning. The scan hang time will still be applied after a received carrier disappears.

### 3. Scan For Channel Guard:

**YES**: The radio will stop scanning only on active channels with the correct Channel Guard. If a scan channel has Channel Guard programmed, the radio will scan only on noise squelch operation for that channel.

**NO**: The radio will ignore Channel Guard and scan only on noise squelch operation.

### 4. Scan Transmit Channel:

**SELECTED** channel (default): The radio will always revert to SELECTED channel when the microphone PTT is keyed or when the microphone is placed off-hook (if off-hook scan is disabled). If signals not being received, the radio will transmit on the SELECTED channel.

### 5. Off-Hook Scan Enable:

**NO**: (default): The radio will stop scanning and flash the SCN indicator when the microphone is off-hook. See the "scan transmit channel" description above to program where the radio will transmit.

**YES**: The radio will continue scanning with the microphone off-hook. See the "scan transmit channel" description above to program where the radio will transmit.

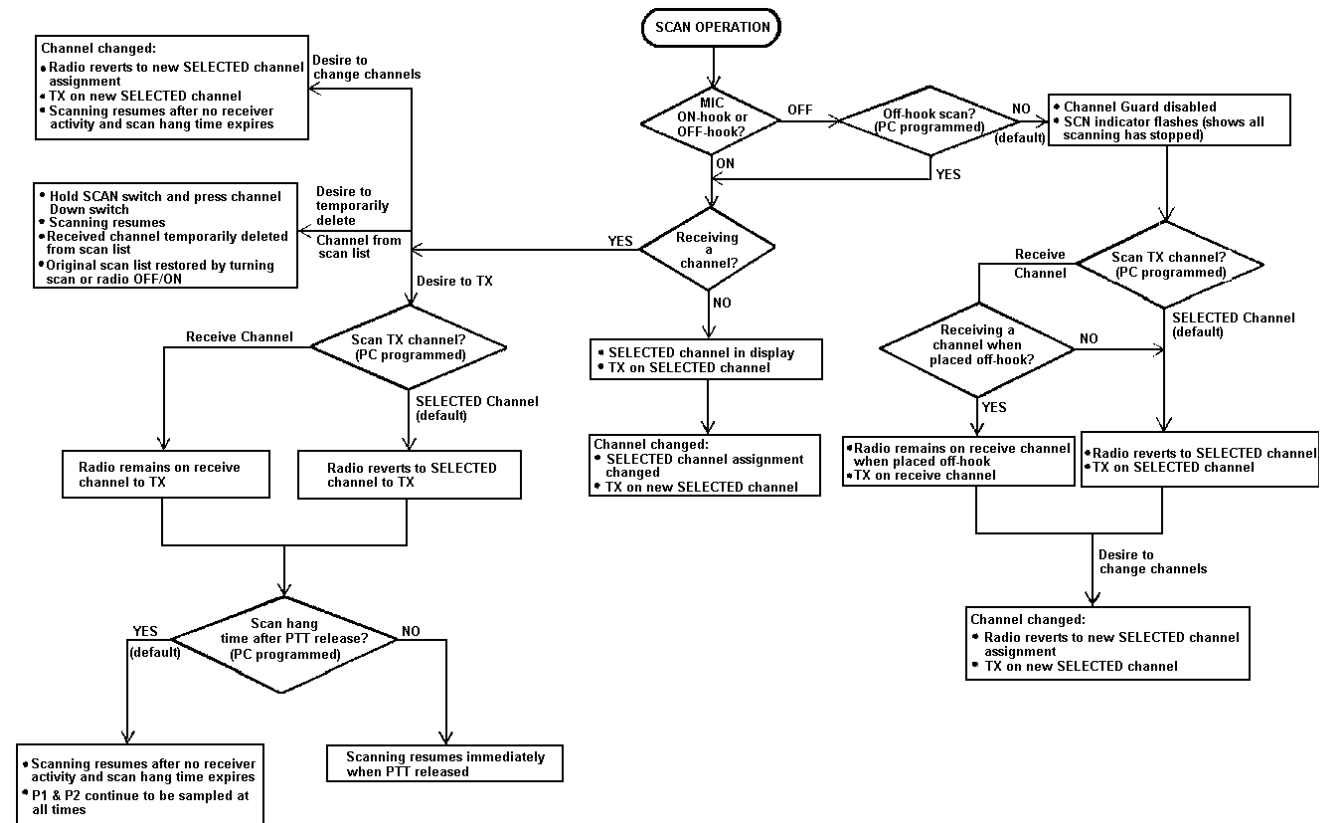

Figure 1 - Scan Operation Flow Chart

### 6. Priority 1 Channel Programming:

- Method 1 - Front programmable (default)

P1 is added to the scan list using the front control panel.

- Method 2 - Fixed P1 Option

P1 channel is PC programmed into the radio personality.

- Method 3 - SELECTED channel option:

The P1 channel follows the SELECTED channel. Each time the scan function is turned on by pushing the SCAN switch, the P1 channel will then follow any changes in the SELECTED channel assignment when the channel switches are pushed.

## DETAILED SCAN OPERATION

The scan operation is controlled by the Audio /Logic Board and provides for scanning any or all of up to 16 channels. The scanned channels may be located anywhere within the frequency band of the radio and can include two priority channels (P1 and P2).

If desired, all 16 channels can be scanned with or without priority level. When SCAN is enabled, scanning of the selected channels starts immediately. Scan time is approximately 15 to 160 milliseconds per channel, depending upon whether Channel Guard has been programmed for a particular scan channel. If a carrier is not detected, the scan time is 15 milliseconds. If a carrier is detected and Channel Guard is programmed for the channel, the scan time is 75-175 milliseconds, depending upon how close the Channel Guard tone is to the desired tone. Typical value is less than 175 milliseconds.

Priority 1 (P1) and Priority 2 (P2) channels, if present, are not part of the non-priority channel scan list (S1, S2, S3,...) and are treated separately. If there is no activity on any of the scanned channels, then the scan sequence is as shown in the following example.

Example 1: (More than four Non-priority channels, i.e., six channels)  
P1-P2-S6-S5-S4-S3-P1-P2-S2-S1-S6-S5-P1-P2-S4-S3-S2-S1-P1-P2-...

Example 2: (Four or less Non-Priority channels, i.e., three channels)  
P1-P2-S3-S2-S1-P1-P2-S3-S2-S1-P1-P2-S3-S2-S1-P1-P2-S3-S2-S1-...

Therefore, the scan sequence is: Scan P1 and P2 programmed. Then scan up to four non-priority channels before scanning P1 and P2 again. If more than four (4) non-priority channels exist, then scan will wrap around, continuously scanning four channels of the non-priority list between each P1, P2

scan sequence. If the number of non-priority channels is less than or equal to four, then all non-priority channels will be scanned between each P1, P2 scan.

As an added example, consider channels 1-8 to be scanned channels, with P1 being channel 1 and P2 being channel 8. The scanning order then would be:

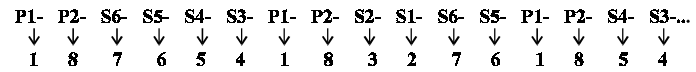

Since it takes approximately 15 to 160 milliseconds to scan each channel, then each Priority channel is sampled every 0.09 to 0.96 seconds and the non-priority channels are sampled at least once every 0.12 to 1.28 seconds. If Channel Guard is programmed for a channel, but no carrier is detected, the scan time for that channel is 15 milliseconds.

**SCANNING (Stopped On A Valid SCAN Channel):**

Once a carrier is detected, the channel display will indicate that channel. If the channel is a non-priority channel and there are no priority channels, then scanning is halted. If only a Priority 2 (P2) channel is present, then it is scanned every 5 seconds if it has Channel Guard programmed and carrier is detected and every second otherwise. If there is only a Priority 1 (P1) channel, then it is sampled every 2.5 seconds if it has Channel Guard and carrier is detected and every 500 milliseconds otherwise. If there are P1 and P2 Priority channels, the sample rate will vary.

In order to show the various scan conditions, the following conditions are used:

**NOTE**

The following conditions are shown while listening to a Non-Priority channel. The "ts" is the "hole" or audio blanking time in the signal being heard while the radio is checking the priority channels for activity.

**CONDITION 1: P1 and P2 have Channel Guard Programmed**

- a. No carriers detected on P1 or P2  
P1-P1-P2-P1-P1-P2-P1-P1-P2-...  
tb (time between samples) =500 msec  
ts (time of sample) =32 msec
- b. Carrier on P1 detected/wrong Channel Guard  
P1-P2-P2-P2-P2-P2-P1-P2-P2-P2-P2-P1-...  
tb=1 second  
ts=32 msec for P2  
75-175 msec for P2

- c. Carrier on P2 detected/wrong Channel Guard  
P1-P2-P1-P1-P1-P1-P1-P1-P1-P1-P2-P1-...  
tb=500 msec  
ts=32 msec for P1  
75-175 msec for P2
- d. Carrier on P1 and P2 detected/both wrong Channel Guard  
P1-P1-P2-P1-P1-P2-P1-P1-P2-...  
tb=2.5 seconds  
ts=75-175 msec
- e. Carrier on P1 and right Channel Guard  
Stop scan, display P1
- f. Carrier on P2 and right Channel Guard  
Display P2, scan P1  
P1-P1-P1-P1-P1-P1-...  
tb=500 msec  
ts=32 msec
- g. Carrier on P2 with right Channel Guard, carrier/wrong Channel Guard on P1  
P1-P1-P1-P1-P1-...  
tb=2.5 seconds  
ts=75-175 msec

**CONDITION 2: Priority 1 has Channel Guard Programmed, Priority 2 does not.**

- a. No carriers detected on P1 or P2  
P1-P1-P2-P1-P1-P2-P1-P1-P2-...  
tb (time between samples) =500 msec  
ts (time of samples) =32 msec
- b. Carrier on P1 detected/wrong Channel Guard  
P1-P2-P2-P2-P2-P2-P1-P2-P2-P2-P2-P1-P2-...  
tb=1 second  
ts=32 msec for P2  
75 -175 msec for P1
- c. Carrier on P1 detected/right Channel Guard  
Stop on P1, stop scan
- d. Carrier on P2  
Stop on P2, scan P1  
P1-P1-P1-P1-...  
tb=500 msec  
ts= 32 msec
- e. Carrier on P2 and P1 with wrong Channel Guard on P1  
Stop on P2, scan P1  
P1-P1-P1-P1-P1-...  
tb=2.5 seconds  
ts=75-175 msec

**CONDITION 3: P2 has Channel Guard, P1 does not**

- a. No carriers detected on P1 or P2  
P1-P1-P2-P1-P1-P2-P1-P1-P2-...  
tb (time between samples) =500 msec  
ts (time of samples) =32 msec
- b. Carrier on P2 detected/wrong Channel Guard  
P1-P2-P1-P1-P1-P1-P1-P1-P1-P1-P2-P1-...  
tb=500 msec  
ts=32 msec for P1  
ts=32 msec  
75-175 msec for P2
- c. Carrier on P2 detected/right Channel Guard  
Stop on P2, scan P1  
P1-P1-P1-P1-P1-P1-...  
tb=500 msec  
ts=32 msec
- d. Carrier on P1 detected  
Stop on P1, stop scan

**CONDITION 4: P1 and P2 with no Channel Guard**

- a. No carriers detected on P1 or P2  
P1-P1-P2-P1-P1-P2-P1-P1-P2-...  
tb (time between samples) =500 msec  
ts (time of sample) =32 msec
- b. Carrier on P2  
P1-P1-P1-P1-P1-P1-...  
tb=500 msec  
ts=32 msec
- c. Carrier on P1  
Stop on P1, stop scan

**PUBLIC ADDRESS OPTION OPERATION**

If the Public Address Option is present, the radio may be used as public address amplifier. Press the programmed flex key or scroll through the menu to select the PA option (Scan must be off). The LED display will show "Pub Addr". When the microphone is keyed, the radio no longer transmits, but allows the microphone audio to feed the speaker. Adjust the VOLUME for the desired level. Press the programmed flex key or scroll through the menu a second time to disable the PA option. The display will return to normal channel display. Changing channels or turning on Scan will also turn the operation off.

The Public Address microphone audio normally feeds an external speaker. An **ON/OFF** switch, which is mounted on or near the radio, allows selecting either the internal or external speaker for the receiver audio. The **ON/OFF** switch turns the receiver audio on or off to the external speaker. This switch still functions for the receiver audio with the PA option disabled.

**TYPE 99 OPTION OPERATION**

If the Type 99 option is present, selective calling is possible. Press the programmed flex key or scroll through the menu to select the T99 decoder option (Scan must be off). The LED display will show "T99 ON" or "T99 OFF" for 2 seconds. During that time subsequent pressing of the flex key or Group/SEL buttons will toggle the T99 state between OFF and ON.

When a T99 call is received, the entire display will alternate between "T99" and the normal channel display and an alert tone will sound. If a call has been received and the display is flashing, **CLR** must be pressed before the T99 option can be turned off.

**DETAILED TYPE 99 OPERATION AND PROGRAMMING**

The optional Type 99 Control Panel provides individual, group and super group call decode. The Motorola Formatted two-tone sequential signaling schemes can also be decode.

In Type 99 Tone systems, calls will not be heard from the receiver until the proper two tones are detected. When the second tone is decoded and recognized as correct, an alert tone sounds during the remaining portion of the second tone. The receiver audio path opens and remains open to receive messages until the decoder is reset. The display will also flash to show a call has been received.

The MDX radio can be PC programmed with up to three separate tables of tones. Either the Ericsson GE Type 99 format or the Motorola format can be assigned to each tone table. The tone decoder can be enabled individually for each channel. Once enabled, one of the three tone tables can be selected for each channel. After choosing a tone table, the call formats must be specified: Individual, Group and Super Group for the Ericsson GE format or Individual, Group and Quick-Call (In Motorola tone systems) allows communication between all radios in a system.



**ERICSSON GE TYPE 99 FORMAT**

Tone frequencies in the Ericsson GE tone system fall within the range of 517.5 to 997.5 Hz.

**NOTE**

A round-off error will occur when entering the tone frequencies. This error is less than 0.2% and will not cause any decoding problems. For example, if the standard tone frequency of 517.5 Hz is entered, the actual decoder frequency will be 517.4 Hz. This new frequency will appear on the screen in the tone tables.

In the Ericsson GE tone format, the first tone may be from tone group A (for individual or Group calls) or from tone group C (for Super Group calls). The second tone may be from tone group B (for individual calls) or from tone group D (for Group and Super Group calls). The Ericsson GE tone format is illustrated as follows:

**ERICSSON GE TYPE 99 FORMAT**

**INDIVIDUAL CALL FORMAT**

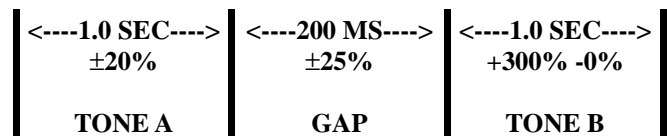

**GROUP CALL FORMAT**

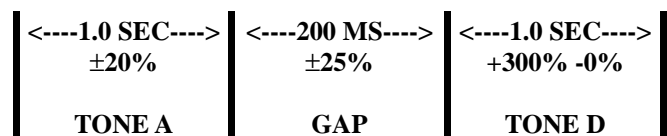

**SUPER GROUP CALL FORMAT**

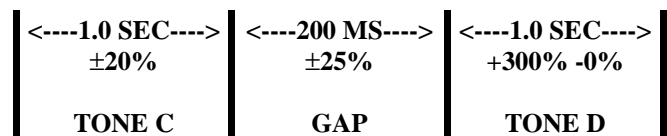

For example, assume the paging number to be **123**. The first digit of the paging number is a **1**. Look in Table 3 and read down the column labeled "**100's Digits**" to a 1. Read horizontally across to the column labeled "**10's Digit**". The tone group is **B**. The second digit of the paging number is a **2**. The tone number is **B2**. Look in Table 3 and down the column labeled "**Tone Designator**" to find B2. Read horizon-

tally across to the column labeled "**Tone Frequency**". The first tone frequency is 787.5 Hz.

To determine the second tone frequency look in Table 3 and as before, find the first digit of the paging number.

The second tone group is A. The third digit of the paging number is a 3 and the Tone Designator is A3. In Table 3 read down the column labeled "**Tone designator**" and find A3. Read horizontally across to the column labeled "**Tone Frequency**". The second tone frequency is 802.5 Hz.

For different paging numbers, locate the first digit in the "**100's Digit**" column and determine the tone frequencies as described in the example. For a complete description of tone applications see **DATAFILE BULLETIN DF-5000-3A**.

Tone D is the diagonal tone used (Ericsson GE tone systems only) when the first and second tone frequencies are the same. The standard frequency for Tone D is 742.5 Hz, but may be programmed with any tone frequency.

Table 3 - Tone Groups

100's DIGIT	10's DIGIT	1's DIGIT
	For 1st Tone	For 2nd Tone
0	A	A
1	B	A
2	B	B
3	A	B
4	C	C
5	C	A
6	C	B
7	A	C
8	B	C
9	Not Used	

Table 4 - Tone Generator Frequencies

TONE GROUP	TONE DESIGNATOR	TONE FREQUENCIES
A	A0	682.5 Hz
	A1	592.5 Hz
	A2	757.5 Hz
	A3	802.5 Hz
	A4	847.5 Hz
	A5	892.5 Hz
	A6	937.5 Hz
	A7	547.5 Hz
	A8	727.5 Hz
	A9	637.5 Hz
B	B0	652.5 Hz
	B1	607.5 Hz
	B2	787.5 Hz
	B3	823.5 Hz
	B4	877.5 Hz
	B5	922.5 Hz
	B6	967.5 Hz
	B7	517.5 Hz
	B8	562.5 Hz
	B9	697.5 Hz
C	C0	667.5 Hz
	C1	712.5 Hz
	C2	772.5 Hz
	C3	817.5 Hz
	C4	862.5 Hz
	C5	907.5 Hz
	C6	952.5 Hz
	C7	532.5 Hz
	C8	577.5 Hz
	C9	622.5 Hz
Diagonal Tone		742.5 Hz

**MOTOROLA FORMAT**

Tone Frequencies in the Motorola tone system fall within the range 288.5 to 1433.4 Hz.

**NOTE**

Tone frequencies above 1000 Hz must be rounded off to the nearest Hz when programming the tone tables. For example, the standard tone frequency of 1153.4 Hz must be entered as 1153 Hz. Also, the program will cause a round-off error of ±0.2 Hz for frequencies below 1000 Hz. These errors will not cause any decoding problems.

In the Motorola tone format, the first tone may be one to three tones: **A** for individual call, **B** for Quick-Call and **C** for Group Call. The second or final tone is **B** in all cases.

The Motorola tone format is illustrated as follows:

**INDIVIDUAL CALL FORMAT**

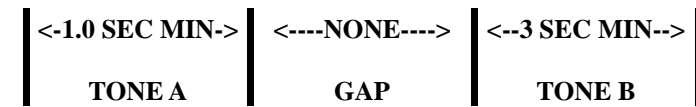

**GROUP CALL FORMAT**

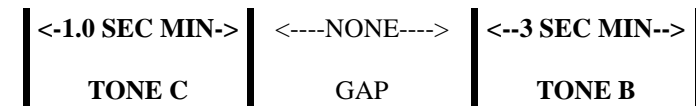

**QUICK CALL FORMAT**

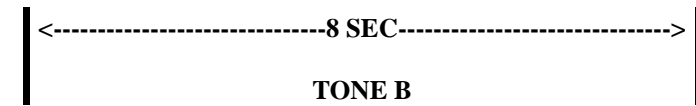

**INDIVIDUAL CALL**

Tables 4 & 5 may also be used to determine the tone frequencies. The first digit of the code determines the tone groups used in the code (See Table 4). Then Table 5 is used to determine the actual tone frequencies.

For a code of 124, the tone groups used are shown in Table 4. Tone A and Tone B are both located in Tone Group 1 and Tone B is tone number 4. Refer to the following examples for additional information.

**EXAMPLE 1 - Code 098:**

The "0" in Table 4 (First Digit of Code) shows that Tone A is Tone Group 4 and Tone B is Tone Group 2 (See Table 5).

Tone number 9 in Tone Group 4 is 524.6 Hz  
Tone number 8 in Tone Group 2 is 879.0 Hz

**EXAMPLE 2 - Code 265:**

The digit "2" in Table 5 shows that both Tone A and Tone B are both in Tone Group 2.

Tone number 6 is 788.5 Hz  
Tone number 5 is 746.8 Hz

Table 5 - Motorola Type Code Numbers

First Digit of Code	Group From Which Tone A Is Selected	Group From Which Tone B Is Selected
1	1	1
2	2	2
3	1	2
4	4	4
5	5	5
6	2	1
7	4	5
8	5	4
9	2	4
0	4	2
A	3	3

**GROUP CALL (Quick-Call Format)**

In Group Call application, the Tone Group is determined by table 7, while the frequency is determined by Table 6. Refer to the following examples.

**NOTE**

Group Call code numbers range from 00 to 99. However, there are several group calls with the same Tone B frequency. This limits the total number of groups called to 40.

**EXAMPLE 1 - Group Call Code 07 (also code 27 and 37):**

The digit "0" in Table 7 shows the Tone B is in Tone Group 2 (TG2) along with 20 to 29 and 30 to 39. Tone number 7 in Tone Group 2 is 832.5 Hz (See Table 6).

**EXAMPLE 2 - Group Call Code 98 (also code 48 and 88):**

The digit "9" in Table 7 shows that Tone B is in Tone Group (TG4) along with 40 to 49 and 80 to 89. Tone number 8 in Tone Group 4 is 496.8 Hz.

Table 6 - Motorola Tone Frequencies and Groups

Tone No.	Tone Group 1	Tone Group 2	Tone Group 3	Tone Group 4	Tone Group 5	Tone Group 6
1	349.0 Hz	600.9 Hz	288.5 Hz	339.6 Hz	584.8 Hz	1153.4 Hz
2	368.5 Hz	634.5 Hz	296.5 Hz	358.6 Hz	617.4 Hz	1185.2 Hz
3	389.0 Hz	669.9 Hz	305.7 Hz	378.6 Hz	651.9 Hz	1217.8 Hz
4	410.8 Hz	707.3 Hz	313.0 Hz	399.8 Hz	688.3 Hz	1251.4 Hz
5	433.7 Hz	746.8 Hz	953.7 Hz	422.1 Hz	726.8 Hz	1285.8 Hz
6	457.9 Hz	788.5 Hz	979.9 Hz	445.7 Hz	767.4 Hz	1321.2 Hz
7	483.5 Hz	832.5 Hz	1006.9 Hz	470.5 Hz	810.2 Hz	1357.6 Hz
8	510.5 Hz	879.0 Hz	1034.7 Hz	496.8 Hz	855.5 Hz	1395.0 Hz
9	539.0 Hz	928.1 Hz	1063.2 Hz	524.6 Hz	903.2 Hz	1433.4 Hz
0	330.5 Hz	569.1 Hz	1092.4 Hz	321.7 Hz	553.9 Hz	1122.5 Hz

Table 7 - Motorola Group Call Tone Groups (TG)

Tone Number	Tone Group
00-09	TG2
10-19	TG1
20-29	TG2
30-39	TG2
40-49	TG4
50-59	TG5
60-69	TG1
70-79	TG5
80-89	TG4
90-99	TG4

MDX™ VHF MOBILE RADIO ASSEMBLY  
19D904183P5 ( Issue 1

SYMBOL	PART NO.	DESCRIPTION
<b>APPLICATION ASSEMBLY 19D904183</b>		
-----ASSEMBLIES-----		
A1	19D904958G1	RF Board (136-153 MHz)
A1	19D904958G2	RF Board (150-174 MHz)
A3	19D901891G3	System Board
A4	19D904025G2	Audio Amplifier Board
A5	19D903963G2	Audio/Logic Board
	19C851540G1	Power Amplifier Board (136-153 MHz)
	19C851540G2	Power Amplifier Board (150-174 MHz)
-----KITS-----		
	344A4253G1	Hardware Kit (No. 1)
	344A4254G1	Hardware Kit (No. 2) Keycap
	344A4255G1	Hardware Kit (No. 3) (136-153 MHz) RF Board
	344A4255G2	Hardware Kit (No. 3) (150-174 MHz) RF Board
	344A2456G1	Hardware Kit (No. 4) (136-153 MHz) PA Board
	344A2456G2	Hardware Kit (No. 4) (150-174 MHz) PA Board
-----CABLES-----		
	19A705301P6	Cable, Antenna
	19A704884P3	Cable, J1 to J103
	19B704884P4	Cable, J2 to J102
	19B801467P1	Cable, J3 to J705 to J704
	19A705235P3	Cable, Ribbon, J901 on Audio Amplifier to J902 on System Board
	19B801454P38	Cable, Antenna to J7
	19B801454P37	Cable, TX to J101
	19B802397P1	Cable, Handset
-----MISCELLANEOUS-----		
	19D904027P1	Casting
	19C337683G2	Bracket
	19D904185G1	Cover, Bottom
	19D904186G1	Cover, Top
	19D904187G1	Panel, Front
	19B801358P18	Cable, 9 Foot, Power
	19B235310P10	Nameplate, Combination

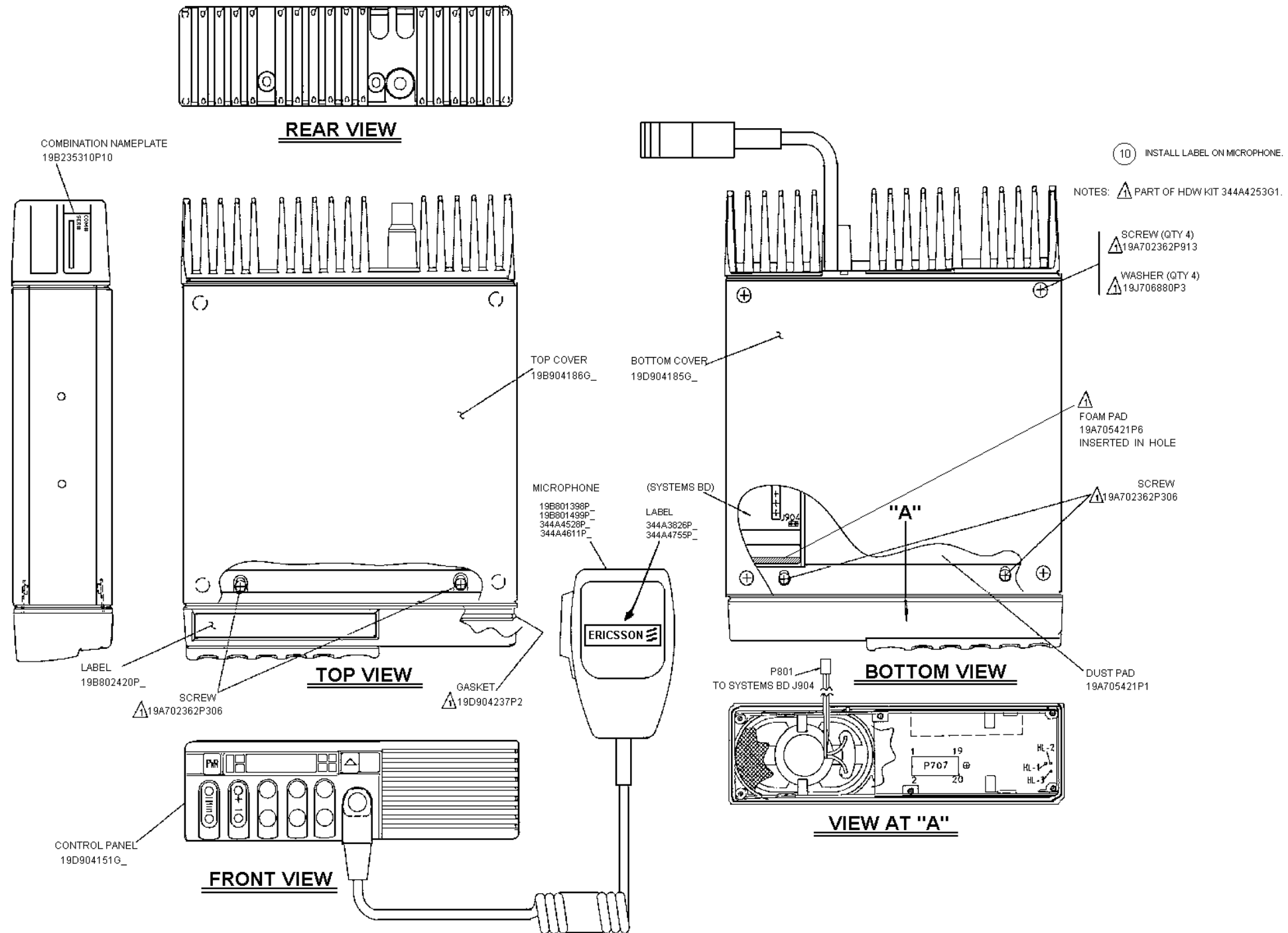

MDX VHF Mobile Radio

(19D904183, Sh. 2, Rev. 12)

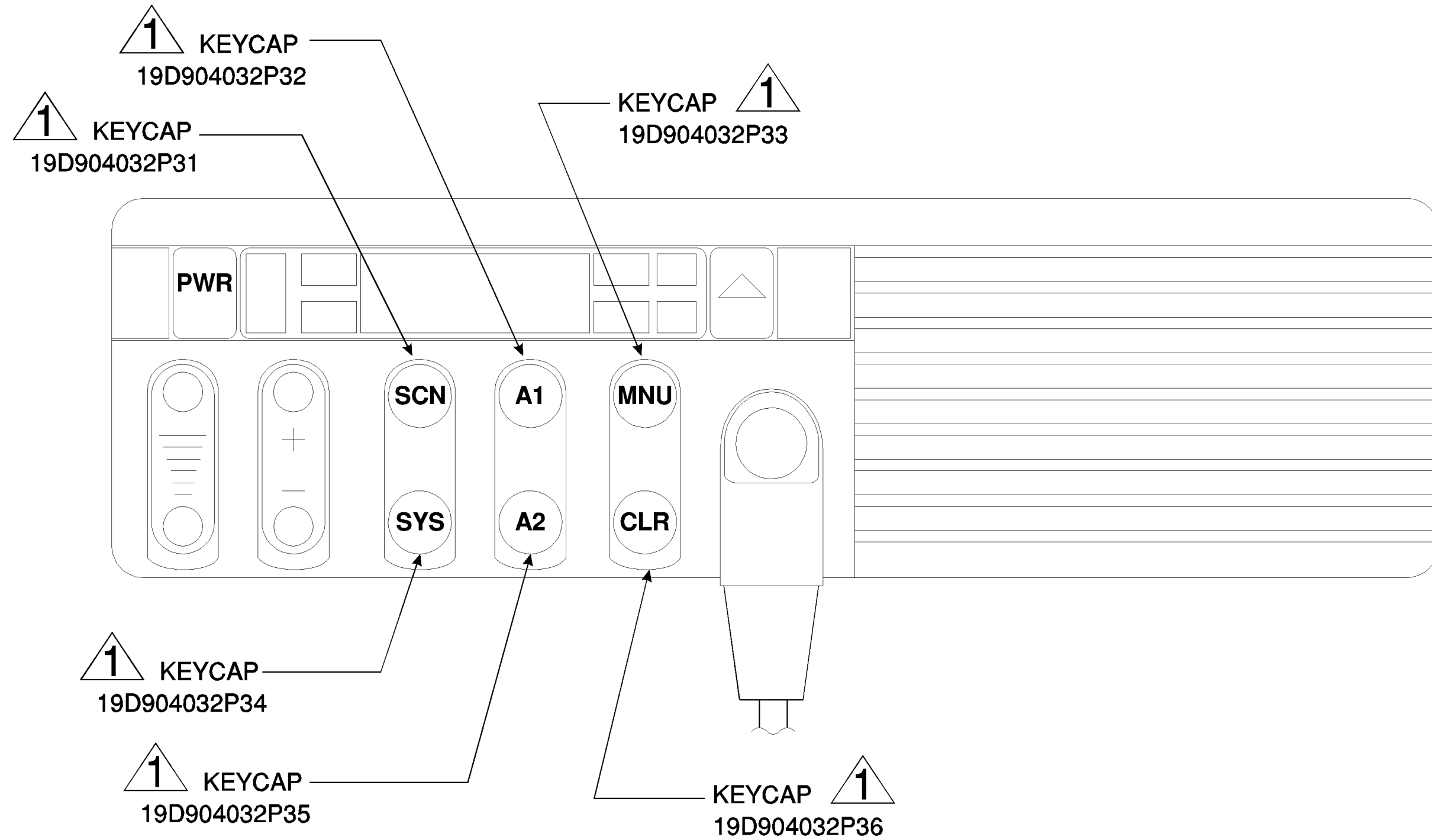

**MDX CONVENTIONAL (SIMPLEX)**

**MDX VHF Mobile Radio**

(19D904183, Sh. 5, Rev. 12)

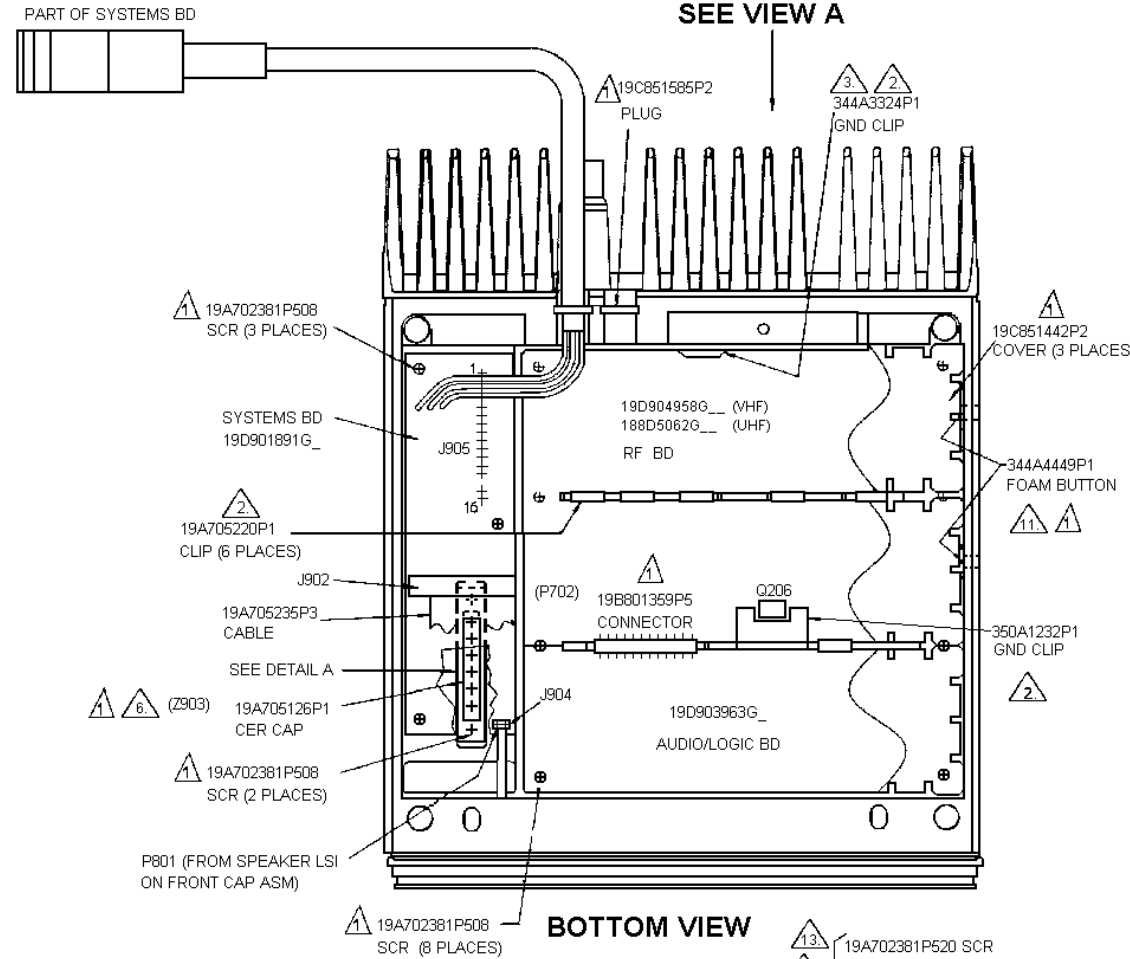
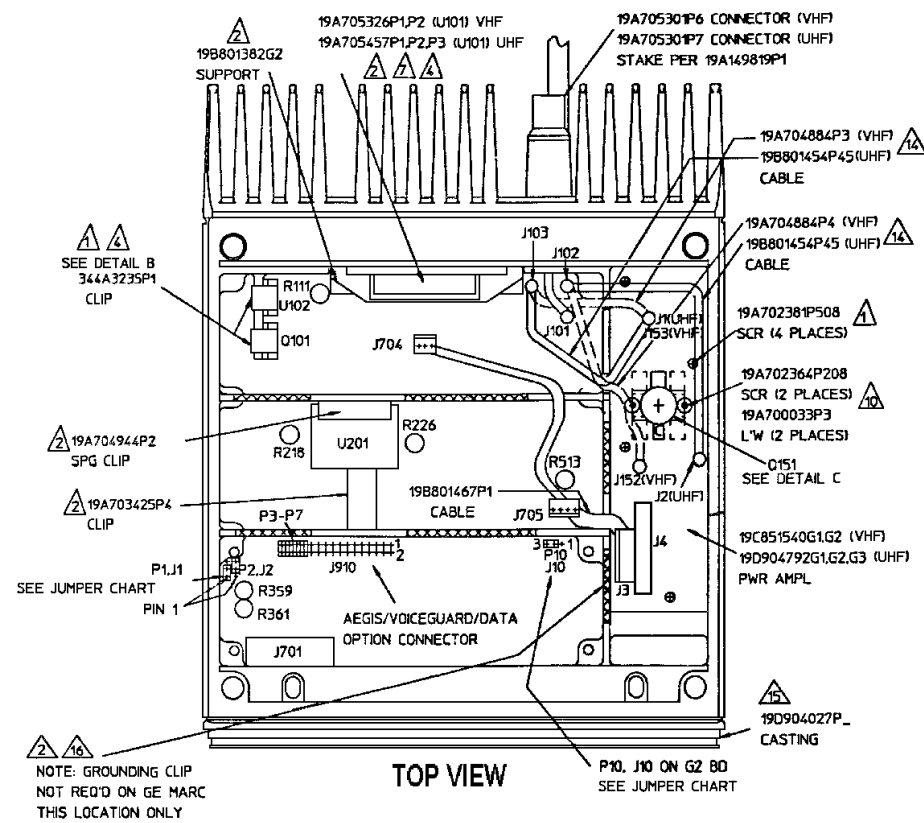

- 5 MDX CONVENTIONAL, UHF & VHF
- NOTES:
- 1 PART OF MDX MARRIAGE HARDWARE KIT 344A4253G1.
  - 2 PART OF RF BD HARDWARE KIT 344A4255G3,4,5,9 (UHF) PART OF RF BD HARDWARE KIT 344A4255G1,2 (VHF) 344A3324P1 GND CLIP NOT USED ON VHF UNITS. 350A1232P1 GND CLIP NOT USED ON VHF UNITS.
  - 3 INSTALL BETWEEN PWB AND CASTING, SOLDER TO PWB.
  - 4 APPLY SILICONE GREASE (19A701337P1) TO PA MOD, Q101 AND U102 ON RF BD AND Q151 ON PA BD ALSO U801 AND U727 ON AUDIO AMPLIFIER BD.
  - 6 LUBRICATE Z903 PINS WITH GREASE (19A704532P1).
  - 7 INSTALL U101 FLUSH TO PWB AND FASTEN WITH SUPPORT TO CASTING BEFORE SOLDERING LEADS TO PWB. TOP OF U101 SHALL NOT EXTEND MORE THAN 0.25 ABOVE ADJACENT CASTING.
  - 8 RECOMMENDED ASSEMBLY PROCEDURE FOR Q151. A. ASSEMBLE ALL MOUNTING HARDWARE LOOSE. B. ALIGN LEADS ON DEVICES WITH MICROSTRIP. POSITION THEM SO THAT MAXIMUM AMOUNT OF LEAD IS IN CONTACT WITH MICROSTRIP. C. PRE TIN LEADS, THEN SOLDER LEADS TO MICROSTRIP USING 2% SILVER. D. TIGHTEN MOUNTING HARDWARE. TORQUE TO 0.6 N.M. (6 IN. LBS.)
  - 9 CARE MUST BE USED IN SOLDERING LEADS OF Q151 TO BD. (A1) TO AVOID SHORTING SOLDER TABS TOGETHER.
  - 10 PART OF PA BD KIT 344A4256G3, 4, 5 (UHF) PART OF PA BD KIT 344A4256G1, 2 (VHF)
  - 11 APPLY OVER TWO HOLES ON INSIDE OF CASTING.
  - 12 P1001 PART OF REMOTE MOUNT.
  - 13 WEATHERPROOF HOLES AROUND SCREWS USING RTV162 (19A701648P2).
  - 14 ROUTE THE TWO PA CABLES AS SHOWN, J103-J153 CABLE THROUGH THE LARGE NOTCH NEAREST HEATSINK. J102-J152 CABLE THROUGH SMALL NOTCH.
  - 15 SECURE GASKET TO CASTING USING RTV3140.
  - 16 19B803825P1 CLIP, GND. 6 PLACES. DENOTED BY CROSS HATCH.

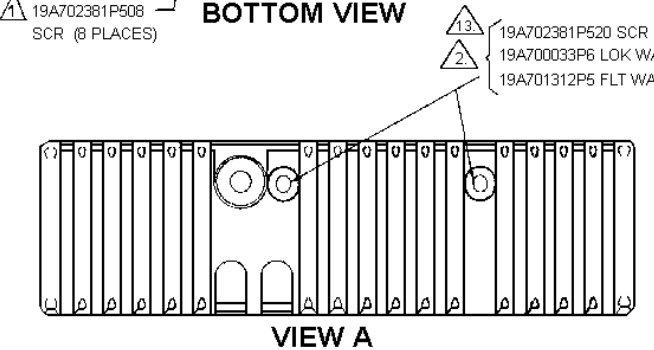
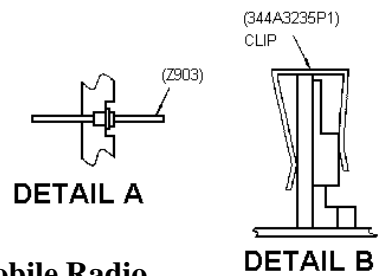
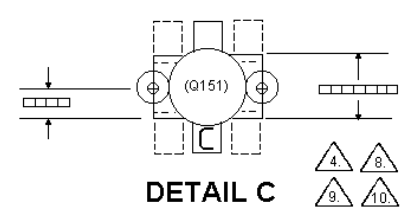
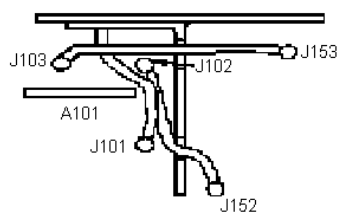
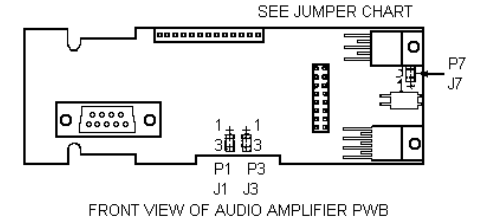
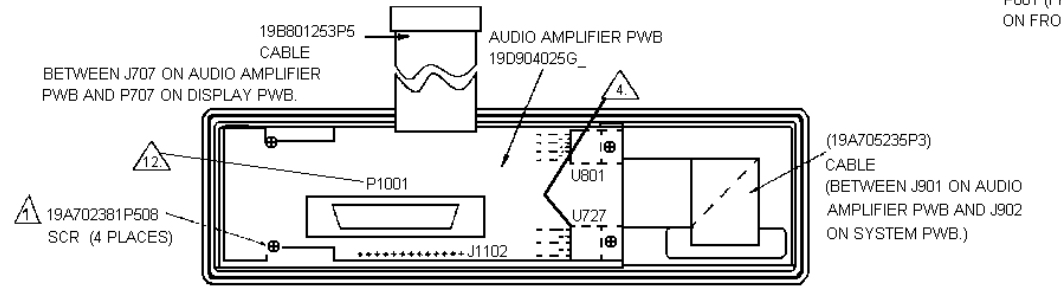

**AUDIO/LOGIC BD JUMPER CHART**

JUMPER	INSTALLATION	NOTES
P1	J1-1&2	BASE BOOST DISABLED
P2	J2-2&3	TX SIDETONE NEG. POLARITY
P3	J910-23 & 24	NO OPTION INSTALLED
P4	J910-25 & 26	NO OPTION INSTALLED
P5	J910-27 & 28	NO OPTION INSTALLED
P6	J910-29 & 30	NO OPTION INSTALLED
P7	J910-31 & 32	NO OPTION INSTALLED
P10	NOT INSTALLED	MDX, 900 MHZ UHF, VHF

**AUDIO AMPLIFIER BD JUMPER CHART**

JUMPER	INSTALLATION	NOTES
P1	J1-1&2	12V SW PW. CONTROLLED
P3	J3-1&2	MODE SELECT HIGH
P7	J7-2&3	SWITCHED SPKR HI AUDIO

**MDX VHF Mobile Radio**

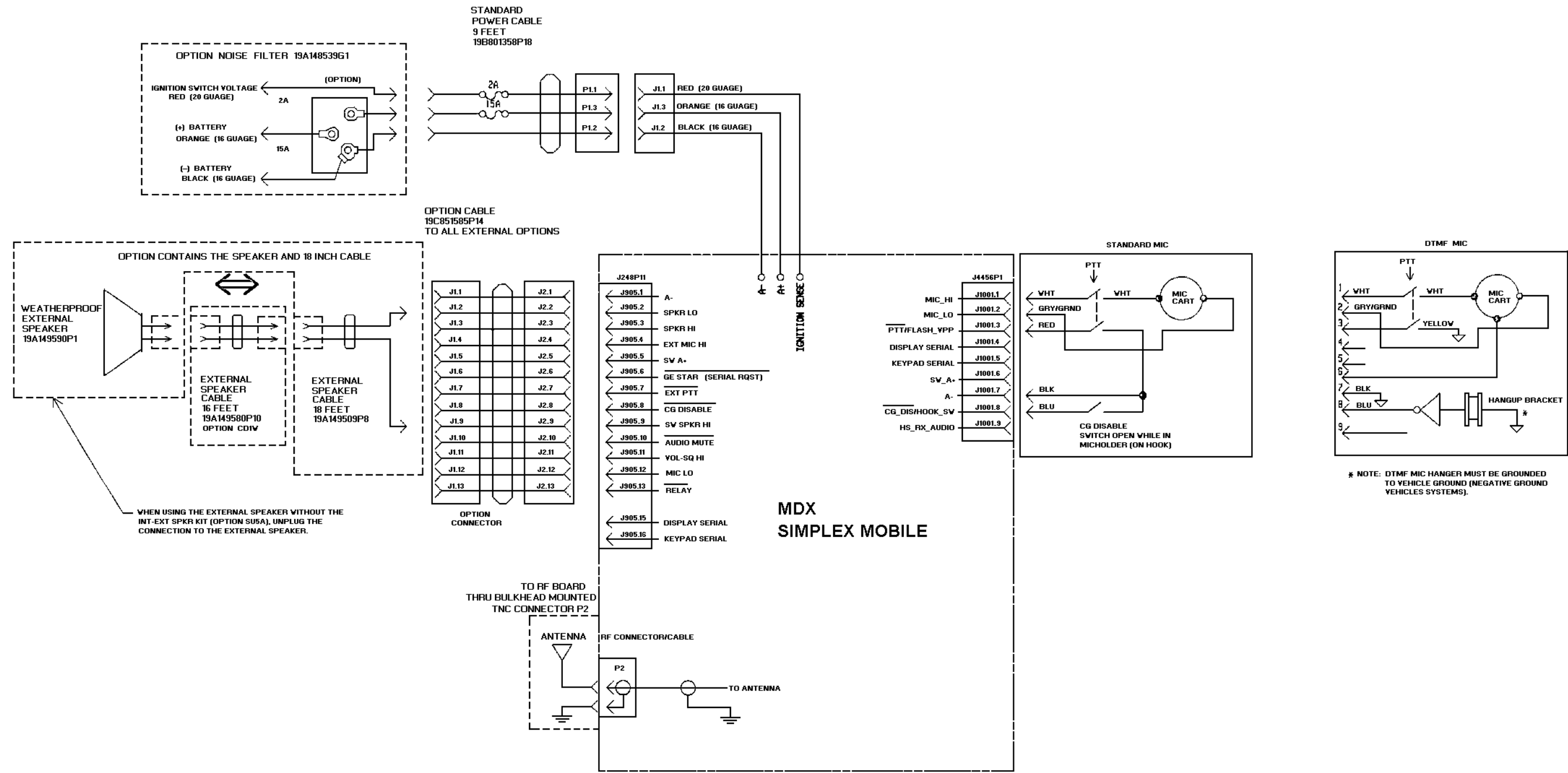

OPTION NUMBER	OPTIONS AVAILABLE	EGE NUMBER
AVIR	ANTENNA, UHF / VHF, ROOFTOP TNC	19B203568P6
CD7V	POWER CABLE, 9 FEET	19B301358P18
CD3A	POWER CABLE, 18 FEET	19B301356P17
MC5P,MC5N	STANDARD MICROPHONE	344A4528P1
MC3V,MC3Z	MIL SPEC. MICROPHONE	344A4528P55
MN1A	MIC HANGER	344A4678P1
MC5K,MC5A	DTMF MIC	344A4611P1
LS1F,LS1H	WATER-PROOF SPEAKER 5" X 5"	19A149590P1
CC9M	EXTERNAL SPEAKER CABLE, 18 INCHES	19A149590P8
CD1V	EXTERNAL SPEAKER CABLE, 16 FEET (REQUIRES CC9M)	19A149590P10
ZMIK,ZM5T	SPEAKER KIT (LS1F, CC9M)	---
CD7Z	OPTION CABLE	19C851585P14
PD1A	NOISE SUPPRESSION KIT	19A148539G1
SUIC	HORN ALARM RELAY KIT	19A705499P1
TQ3372	PC PROGRAMMER CABLE	19B801417P9
TQ3373	PC PROGRAMMING SOFTWARE (EDACS, GEMARC&CONV)	---
TQ3346	PC PROGRAMMING SOFTWARE (GEMARC&CONV)	---
#	MOUNTING BRACKET KIT	19A138051G11
ZM5S	18 FEET REMOTE MOUNT KIT	---
SU5A	PUBLIC ADDRESS RELAY/EXT SPEAKER RELAY KIT	19C851585P17
CY1B	DC REMOTE CONTROL	19A704666P7
TQ3370	PC PROGRAMMING/FLASH INTERFACE BOX	19D438367G2
ZMSR,ZM5U	MIC AND HANGER, MIL SPEC.	---
YS826	QUICK RELEASE SLIDE MOUNT KIT	---

\* OPTIONS ARE STANDARD

NOTE 1  
FOR A COMPLETE LISTING OF OPTIONS SEE YOUR AUTHORIZED EGE DEALER.

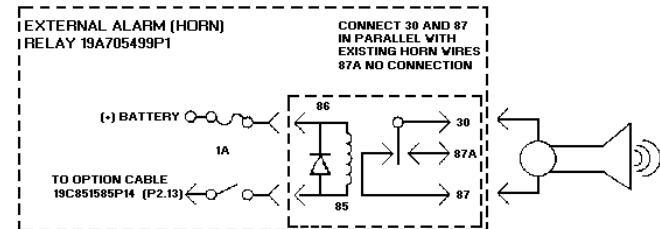
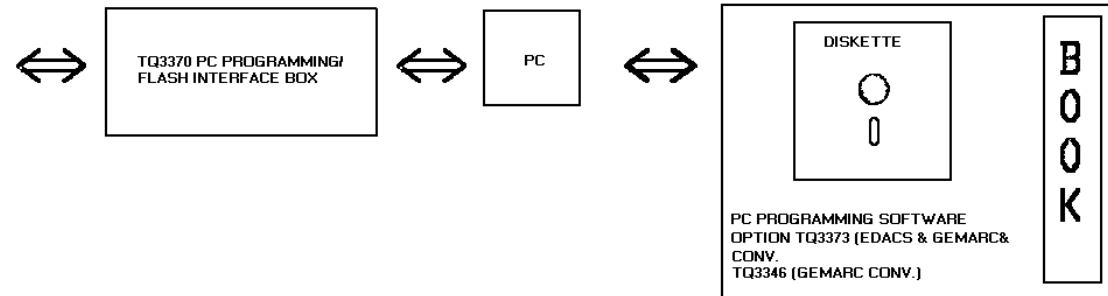
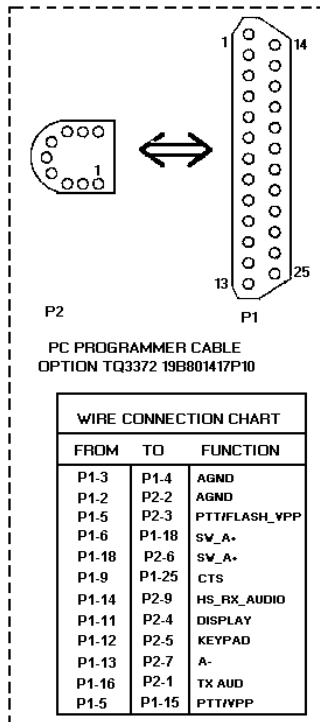
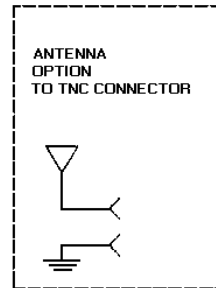
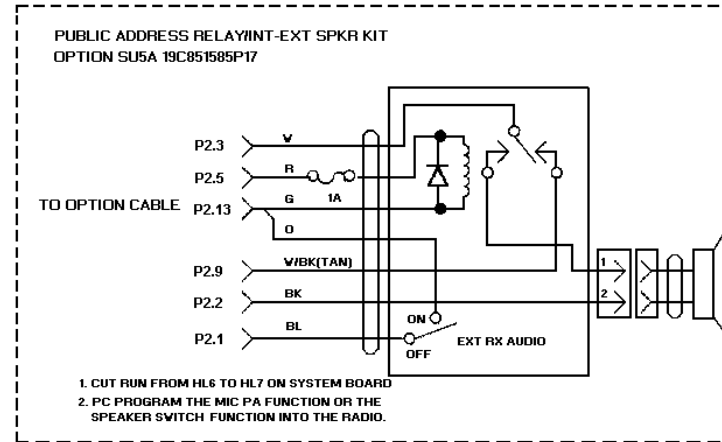
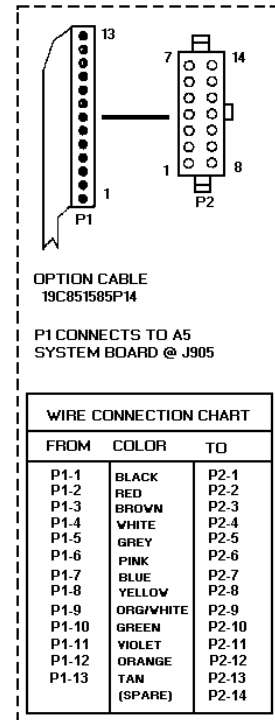

MDX VHF Mobile Radio

(188D5198, Sh. 3, Rev. 0)

