

MAINTENANCE MANUAL

FOR

800 MHz TRANSMITTER SYNTHESIZER MODULE

19D902780G5

TABLE OF CONTENTS

	<u>Page</u>
DESCRIPTION	
GENERAL SPECIFICATIONS	Front Cover
CIRCUIT ANALYSIS	1
VOLTAGE CONTROLLED OSCILLATOR	1
FREQUENCY DOUBLER	1
RF AMPLIFIERS	1
REFERENCE BUFFER AMPLIFIER	1
PRESCALER AND SYNTHESIZER	1
LOOP BUFFER AMPLIFIERS	2
AUDIO FREQUENCY AMPLIFIER	2
VOLTAGE REGULATORS	2
LOGIC CIRCUITRY	2
BLOCK DIAGRAM	2
MAINTENANCE	2
TEST PROCEDURE	3
ALIGNMENT PROCEDURE	3
TROUBLESHOOTING	3
PARTS LIST	4&5
IC DATA	6
OUTLINE DIAGRAM	7
ASSEMBLY DIAGRAM	8
SCHEMATIC DIAGRAM	9

DESCRIPTION

The principle function of the Transmitter Synthesizer Module is to provide the RF excitation for input to the MASTR III station power amplifier. The output of the synthesizer is a frequency modulated signal at the desired frequency. The module contains the following functional blocks:

- A voltage controlled oscillator.
- RF Buffer and Divide by 2 Prescaler.
- A chain of integrated circuit RF Amplifiers.
- A reference buffer amplifier.
- Dual modulus prescaler and synthesizer integrated circuits.
- Loop amplifier and active loop filter.
- An audio amplifier and a pre-modulation integrator.
- IC voltage regulator for +5 Vdc. A discrete component regulator for +10 Vdc.
- Logic circuitry: address decoder, input signal gates, and a lock indicator circuit.

Table 1 - General Specifications

ITEM	SPECIFICATION
FREQUENCY RANGE	851-870 MHz
LOCK RANGE	500 kHz
CHANNEL SPACING	12.5 kHz
RF POWER OUT(50 Ohm load)	10 to 13 dBm (10 to 20 mW)
RF HARMONICS	< -30 dBc
NON-HARMONIC SPURS	
1 to 200 MHz	<- 90 dBc
200 MHz to 1 GHz	< -60 dBc
CARRIER ATTACK TIME	< 50 mSec
REFERENCE INPUT	
Input level	0 dBm \pm 1.5 dB
Input impedance	50 Ohm
Frequency	5 to 17.925 MHz (must be integer divisible by channel spacing)
MODULATION SENSITIVITY	5 kHz peak dev/1 Vrms, Adjustable
AF INPUT IMPEDANCE	600 Ohm
AF RESPONSE	
10 Hz	\pm 1.5 dB
1000 Hz	0 dB reference
3 kHz	\pm 1.5 dB
10 Hz SQUARE WAVE MODULATION	
Sq Wave Droop	<10%
HUM & NOISE	-53 dB
POWER REQUIREMENTS	13.8 Vdc @325 mA

CIRCUIT ANALYSIS

VOLTAGE CONTROLLED OSCILLATOR

Amplifier U1 and associated circuitry comprise a low noise voltage controlled oscillator. The oscillation frequency is determined by a temperature compensated dielectric resonator/metallic cavity combination. The oscillator is designed to operate at twice the station transmitter frequency in order to maintain a relatively small cavity size. The resonator is inductively coupled to the amplifier U1. Also, the oscillator output signal is provided by inductive coupling within the cavity.

Two methods of changing the oscillator frequency are provided:

- 1) Mechanical tuning
- 2) Electrical tuning

Mechanical frequency adjustment is provided by a tuning screw which penetrates the oscillator cavity. Frequency change is caused by the interaction of the screw and the internal cavity fields. Mechanical adjustments over the full 19 MHz range is available.

Electrical frequency adjustment is provided by two voltage variable capacitance diodes (varicaps), D1 and D2. These diodes are inductively coupled to the resonator. Both the synthesizer control voltage and AF voltage for modulation are applied to the diodes. Electrical tuning is restricted to a 500 kHz range.

BUFFER AMPS AND DIVIDE BY 2 PRESCALER

The output of the Voltage Controller Oscillator is fed to MMIC Amplifier U901, which buffers the signal and drives ECL Prescaler U902. This divide by 2 device converts the signal from 1702-1740 MHz, down to 851-870 MHz. The output of U902 is buffered by MMIC Amplifier U903 and fed to a chain of RF amplifiers.

RF AMPLIFIERS

The RF Amplifiers begins with resistive splitter R201-R204, R216-R218. The output of the splitter at R203 is attenuated by 10 dB and provides match to drive MMIC amplifier U201 into compression. U201 drives output amplifier U202 into compression, with a gain of about 9 dB. The output amplifier is followed by a bandpass filter (FL201), a lowpass filter (C216, C217, L203) and resistive attenuator (R213-R215). These circuits suppress harmonic content, and provide a good 50 ohm port at J2. The final output at the front panel BNC Connector (J2) is nominally 11.5 dBm, and drives the station power amplifier.

The other output of the resistive splitter at R218 is attenuated by 10 dB and drives MMIC compression amplifier U203. This amplifier drives the synthesizer prescaler, providing a feedback signal for the synthesizer phase locked loop.

REFERENCE BUFFER AMPLIFIER

Transistor Q401 and associated components comprise an amplifier for the 12.8 MHz reference signal. The reference oscillator is located in the receiver synthesizer module of a MASTR III station. The 0 dBm reference signal is fed through the front panel BNC Connector J1. R405 provides a 50 ohm load to the reference oscillator. The output of the reference signal amplifier is fed directly to the synthesizer integrated circuit. The output level is approximately 3 V peak-to-peak AC.

PRESCALER & SYNTHESIZER

Integrated circuit U402 is the heart of the synthesizer. It contains the necessary frequency dividers and control circuitry to synthesize output frequencies by the technique of dual modulus prescaling. U402 also contains an analog sample and hold phase detector and a lock detector circuit.

On board U402 are three programmable dividers which are loaded serially using the clock, data, and enable inputs (pins 11, 12, and 13 respectively). A serial data stream on data input pin 12 is shifted into internal shift registers by low

to high transitions on the clock input pin 11. A logic high on enable pin 13 then transfers the program information from the shift registers to the divider latches.

The 12.8 MHz reference signal applied to pin 2 of U402 is divided by the 14-bit "R" divider within the integrated circuit. In the case of the 800 MHz transmitter synthesizer, R=1024 in order to divide the 12.8 MHz signal down to 12.5 kHz (Fr.). This provides synthesizer steps of 12.5 kHz required to cover both 12.5 kHz and 25 kHz channel spacings.

The 7-bit "A" divider and 10-bit "N" divider serve to process the loop feedback signal provided by the Voltage controlled oscillator (by way of the dual modulus prescaler U401). Therefore the output of the "N" divider (Fv) is a divided version of the voltage controlled oscillator output.

Synthesizer integrated circuit U402 also contains logic circuitry to control the dual modulus prescaler U401. This prescaler is characterized by $P/(P+1) = 128/129$. Under locked conditions the voltage controlled oscillator output frequency $F_{out} = N_{total} * F_r$, where $N_{total} = N * P + A$. N and A must be programmed properly for any given synthesizer output frequency.

Example:

$$\begin{aligned} \text{For Desired } F_{out} &= 860 \text{ MHz} \\ \text{with } F_r &= 12.5 \text{ kHz} \\ \text{and } P &= 128 \end{aligned}$$

$$N_{total} = F_{out}/F_r = 68800$$

Assuming A=0, the $N = N_{total}/P = 537.5$ but N must be integer, therefore $N = 537$

The fractional part of N_{total}/P is accounted for by A

$$A = N_{total} - N * P = 64$$

In this example, the locked synthesizer output frequency is 860 MHz. The prescaler output nominally will be equal to $860 \text{ MHz}/P = 6.71875 \text{ MHz}$. This frequency is further divided down to Fv by the "N" divider in U402. Fv is then compared with Fr in the phase detector.

The phase detector output is a voltage which is proportional to the phase difference between Fv and Fr. This phase detector output serves as the loop error signal. This error voltage forces the voltage controlled oscillator to whatever frequency is required to keep Fv and Fr locked (identical).

TEST PROCEDURE

(Steps 5, 6, and 7 can be done using a modulation analyzer or 800 MHz receiver with 750µs de-emphasis switchable in or out.

1. Lock synthesizer at 860.5 MHz using software provided in the service parts kit.
 - Verify lock (flag = high).
 - Verify front panel LED is off.
2. Measure output frequency.
 - Verify frequency = 860.5000 MHz ±500 Hz.
3. Measure harmonic content (1721 MHz).
 - Verify 2nd harmonic is < -30 dBc.
4. Measure RF power output into 50 ohm load.
 - Verify 10 to 13 dBm (10 to 20 mW).
5. Measure AF distortion with standard modulating signal input.
 - Verify <5%.
6. Measure Hum and Noise relative to 0.44 kHz average deviation, (de-emphasis on).
 - Verify < -55dB
7. Measure AF response at 300 Hz, 1 kHz (ref) and 3 kHz, (de-emphasis off).
 - Verify within ±1.5 dB with respect to 1 kHz reference.
8. Verify lock at different frequencies.
 - a. Lock synthesizer at 860.0 MHz. Verify LED is off.
 - b. Lock synthesizer at 860.25 MHz. Verify LED is off.
 - c. Lock synthesizer at 860.75 MHz. Verify LED is off.
 - d. Lock synthesizer at 861.0 MHz. Verify LED is off.

SERVICE NOTES

The following service information applies when aligning, testing, or troubleshooting the TX Synthesizer:

- Standard Modulating Signal = 1 kHz sinusoidal voltage, 0.6 Vrms at the module input terminals (600 ohm R_{in}).
- Logic Levels:
Logic 1 = high = 4.5 to 5.5 Vdc
Logic 0 = Low = 0 to 0.5 Vdc
- Transmitter Synthesizer Address = A0 A1 A2 = 110
- Synthesizer data input stream is as follows:

14-bit "R" divider most significant bit (MSB) = R13 through "R" divider least significant bit (LSB) = R0

10-bit "N" divider MSB = N9 through "N0" divider, LSB = N0

7-bit "A" divider MSB = A6 through "A0" divider, LSB = A0

Single high Control bit (last bit)

Latched When Control Bit = 1

DATA ENTRY FORMAT

Latched When Control Bit = 1

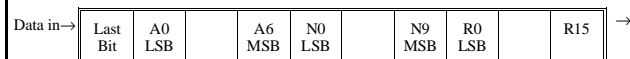

For the transmitter synthesizer, 12.5 kHz channel spacing
 R = 1024
 N = integer part of (frequency in kHz)/(320)
 A = (frequency in kHz)/(5) - 12.8*N
 All numbers must be converted to binary.

- ANT_REL line must be logic low (0V) in order to lock synthesizer.
- Synthesizer lock is indicated by the extinguishing of the front panel LED indicator and a logic high on the fault flag line (J3 pin 13C).
- Always verify synthesizer lock after each new data loading.

ALIGNMENT PROCEDURE

1. Apply +13.8 Vdc. Verify the current drain on the 13.8 volt supply is 860.5 MHz <400 mA.
2. Lock the synthesizer at 860.5 MHz <400 mA. Adjust trimmer slug until Vtest (23A) reads 5.0 ±0.05V.
3. Lock synthesizer at 860.5 MHz for the following three adjustments.
 - Set VR602 for 4.5 kHz peak deviation with a standard modulating signal applied to the audio input.

- Set VR601 for 4.5 kHz peak deviation with 0.6 Vrms, 10 Hz sine wave audio applied to module AF input.
- Apply a 10 Hz 0.85 Vpk square wave (same peak value as 0.6 rms (sine wave) to module AF input. Adjust VR601 slightly for the flattest demodulated square wave using a modulation analyzer or receiver (no de-emphasis) and an oscilloscope. The maximum net variation in voltage over 1/2 cycle is ±10%.

TROUBLESHOOTING

A troubleshooting guide is provided showing typical measurements at the various test points.

TROUBLESHOOTING GUIDE

SYMPTOM	CHECK (CORRECT READINGS SHOWN)	INCORRECT READING INDICATES DEFECTIVE COMPONENT
SYNTHESIZER FAILS TO LOCK	Check DC voltages +5 V @ U301 Pin 1 +10V @ Q301 collector Check 12.8 MHz reference signal 3V P-P, 12.8 MHz @ U402 Pin 2 Check oscillator signal 11.5 ±1.5 dBm 850 to 870 MHz at front panel BNC Check prescaler output 1V P-P, 6.7 MHz @ U401 Pin 4 Check CLOCK, DATA, ENABLE While loading frequency data into synthesizer Check 8V logic signals @ Pins 11, 12, 13 of U402 Check Phase detector output 12.5 kHz random signal @ U402 Pin 15	U301 or associated components U301, Q301, Q302 or associated components No reference signal to front panel BNC or Q401 Proceed to "Low/No RF output" below U203, U401 Wrong address or U701, U702, Q701, Q702, Q703 U402, U501
Low/No RF Output	Check oscillator Check RF chain	
No Modulation	Check AF amplifier Apply 1V, 1 kHz signal to TX/Audio/Hi Check 1V signal @ U601 Pin 7	U601

**UHF TRANSMITTER SYNTHESIZER MODULE
19D902780G5
ISSUE 1**

SYMBOL	PART NUMBER	DESCRIPTION
		----- MISCELLANEOUS -----
2	19D902508P4	Chassis.
3	19D902509P2	Cover.
4	19D902555P1	Handle.
6	19A702381P506	Screw, thread forming: TORX, No. M3.5-.6 x 6.
7	19A702381P513	Screw, thread forming: TORX, No. M3.5 - 0.6 X 13.
8	19B235310P1	Nameplate.
11	19A702381P508	Screw, thd. form: No. 3.5-0.6 x 8.
12	19D902824P1	Casting.
22	19D902509P6	Cover.
23	19A702381P508	Screw, thd. form: No. 3.5-0.6 x 8.
24	19D904877P1	Cover.
25	19C852430P1	Screw: Tuning.
26	19A701800P1	Stop nut.
27	RTMUA50101/2	Screw, tuning.
28	RTMUA50101/3	Spacer.
29	SBA401040/0250	Screw: Nylon.
30	19A702381P1406	Screw: M2.5 x 6, Thread Forming, Pan Head, Torx Drive, Zinc Plated.
		TRANSMITTER SYNTHESIZER BOARD 19D902779G5
		----- CAPACITORS -----
C1	19A705205P2	Tantalum: 1 μ F, 16 VDCW; sim to Sprague 293D.
C2		Ceramic: 0.01 μ F \pm 10%, 50 VDCW.
C3 thru C6	19A702236P28	Ceramic: 12 pF \pm 5%, 50 VDCW, temp coef 0 \pm 30 PPM. <small>50%, 50 VDCW, temp coef 0 30 PPM.</small>
C7	19A702052P14	Ceramic: 0.01 μ F \pm 10%, 50 VDCW.
C8	19A705205P2	Tantalum: 1 μ F, 16 VDCW; sim to Sprague 293D.
C9 and C10	19A702236P28	Ceramic: 12 pF \pm 5%, 50 VDCW, temp coef 0 30 PPM.
C201 and C202	19A702236P38	Ceramic: 33 pF \pm 5%, 50 VDCW, temp coef 0 \pm 30 PPM/ $^{\circ}$ C.
C203	19A702052P14	Ceramic: 0.01 μ F \pm 10%, 50 VDCW.
C204 thru C206	19A702236P38	Ceramic: 33 pF \pm 5%, 50 VDCW, temp coef 0 \pm 30 PPM/ $^{\circ}$ C.
C207	19A702052P14	Ceramic: 0.01 μ F \pm 10%, 50 VDCW.
C211 and C212	19A702236P38	Ceramic: 33 pF \pm 5%, 50 VDCW, temp coef 0 \pm 30 PPM/ $^{\circ}$ C.
C213	19A702052P14	Ceramic: 0.01 μ F \pm 10%, 50 VDCW.
C214 and C215	19A702236P38	Ceramic: 33 pF \pm 5%, 50 VDCW, temp coef 0 30 PPM/ $^{\circ}$ C.
C216 and C217	19A702236P12	Ceramic: 3.0 pF \pm 0.25 pF, 50 VDCW; temp coef 0 \pm 30 PPM.
C301	19A702061P99	Ceramic: 1000 pF \pm 5%, 50 VDCW, temp coef 0 \pm 30 PPM/ $^{\circ}$ C.
C302	19A702052P14	Ceramic: 0.01 μ F \pm 10%, 50 VDCW.

SYMBOL	PART NUMBER	DESCRIPTION
C303 and C304	19A705205P13	Tantalum: 4.7 μ F, 10 VDCW; sim to Sprague 293D.
C305	19A705205P7	Tantalum: 10 μ F, 25 VDCW; sim to Sprague 293D.
C306	19A705205P2	Tantalum: 1 μ F, 16 VDCW; sim to Sprague 293D.
C307	19A705205P6	Tantalum: 10 μ F, 16 VDCW; sim to Sprague 293D.
C314 and C315	19A705205P6	Tantalum: 10 μ F, 16 VDCW; sim to Sprague 293D.
C316	19A702052P14	Ceramic: 0.01 μ F \pm 10%, 50 VDCW.
C401	19A702052P14	Ceramic: 0.01 μ F \pm 10%, 50 VDCW.
C402	19A702061P99	Ceramic: 1000 pF \pm 5%, 50 VDCW, temp coef 0 \pm 30 PPM/ $^{\circ}$ C.
C403 thru C405	19A702052P14	Ceramic: 0.01 μ F \pm 10%, 50 VDCW.
C406	19A702061P99	Ceramic: 1000 pF \pm 5%, 50 VDCW, temp coef 0 \pm 30 PPM/ $^{\circ}$ C.
C407	19A702052P14	Ceramic: 0.01 μ F \pm 10%, 50 VDCW.
C408	19A702061P99	Ceramic: 1000 pF \pm 5%, 50 VDCW, temp coef 0 \pm 30 PPM/ $^{\circ}$ C.
C409	19A705205P6	Tantalum: 10 μ F, 16 VDCW; sim to Sprague 293D.
C410	19A702052P33	Ceramic: 0.1 μ F \pm 10%, 50 VDCW.
C411	19A705205P6	Tantalum: 10 μ F, 16 VDCW; sim to Sprague 293D.
C412	19A702052P14	Ceramic: 0.01 μ F \pm 10%, 50 VDCW.
C413	19A702052P108	Ceramic: 0.01 μ F \pm 10%, 50 VDCW.
C414	19A702061P69	Ceramic: 220 pF \pm 5%, 50 VDCW, temp coef 0 \pm 30 PPM/ $^{\circ}$ C.
C415	19A705205P2	Tantalum: 1 μ F, 16 VDCW; sim to Sprague 293D.
C502	19A705205P2	Tantalum: 1 μ F, 16 VDCW; sim to Sprague 293D.
C503	19A702052P33	Ceramic: 0.1 μ F \pm 10%, 50 VDCW.
C504	19A702061P99	Ceramic: 1000 pF \pm 5%, 50 VDCW, temp coef 0 \pm 30 PPM/ $^{\circ}$ C.
C505	19A703684P3	Polyester: 2.2 μ F, 50 VDCW.
C506	19A702250P113	Polyester: 0.1 μ F \pm 10%, 50 VDCW.
C507	19A702052P33	Ceramic: 0.1 μ F \pm 10%, 50 VDCW.
C508	19A702250P113	Polyester: 0.1 μ F \pm 10%, 50 VDCW.
C602	19A705205P6	Tantalum: 10 μ F, 16 VDCW; sim to Sprague 293D.
C603	19A702061P99	Ceramic: 1000 pF \pm 5%, 50 VDCW, temp coef 0 30 PPM/ $^{\circ}$ C.
C604	19A705205P2	Tantalum: 1 μ F, 16 VDCW; sim to Sprague 293D.
C605	19A703684P3	Polyester: 2.2 μ F, 50 VDCW.
C606	19A705205P6	Tantalum: 10 μ F, 16 VDCW; sim to Sprague 293D.
C701 thru C712	19A702061P61	Ceramic: 100 pF \pm 5%, 50 VDCW, temp coef 0 \pm 30 PPM.
C714 and C715	19A702061P99	Ceramic: 1000 pF \pm 5%, 50 VDCW, temp coef 0 \pm 30 PPM/ $^{\circ}$ C.
C716 and C717	19A702061P99	Ceramic: 1000 pF \pm 5%, 50 VDCW, temp coef 0 \pm 30 PPM/ $^{\circ}$ C.
C901 thru C903	19A702236P28	Ceramic: 12 pF \pm 5%, 50 VDCW, temp coef 0 \pm 30 PPM.
C904	19A702052P14	Ceramic: 0.01 μ F \pm 10%, 50 VDCW.

SYMBOL	PART NO.	DESCRIPTION
C905	19A702236P28	Ceramic: 12 pF \pm 5%, 50 VDCW, temp coef 0 \pm 30 PPM.
C906	19A702236P38	Ceramic: 33 pF \pm 5%, 50 VDCW, temp coef 0 \pm 30 PPM/ $^{\circ}$ C.
C907	19A702052P14	Ceramic: 0.01 μ F \pm 10%, 50 VDCW.
C908 thru C910	19A702236P38	Ceramic: 33 pF \pm 5%, 50 VDCW, temp coef 0 \pm 30 PPM/ $^{\circ}$ C.
C911	19A702052P14	Ceramic: 0.01 μ F \pm 10%, 50 VDCW.
C912	19A702236P38	Ceramic: 33 pF \pm 5%, 50 VDCW, temp coef 0 \pm 30 PPM/ $^{\circ}$ C.
		----- DIODES -----
CR701	19A703595P10	Optoelectric: Red LED; sim to HP HLMP-1301-010.
D1 and D2	RKZ320603	Diode: Variable capacitance.
D401	19A703561P2	Silicon, fast recovery (2 diodes in series).
		----- FILTERS -----
FL201	19A704888P1	Bandpass Filter, 851-871 MHz; sim to: Murata DFC3R861P020BTD.
		----- JACKS -----
J1 and J2	19A115938P24	Coaxial Connector.
J3	19B801587P7	Connector, DIN: 96 male contacts, right angle mounting; sim to AMP 650887-1.
		----- INDUCTORS -----
L1 and L2	19A705470P8	Coil, Fixed: 39 nH; sim to Toko 380NB-39nM.
L202	19A705470P5	Coil, Fixed: 22 nH; sim to Toko 380NB-22nM.
L203	344A4540P100	Inductor, surface mount: 10 nH \pm 5%.
L301	19A705470P8	Coil, Fixed: 39 nH; sim to Toko 380NB-39nM.
L501	19A705470P8	Coil, Fixed: 39 nH; sim to Toko 380NB-39nM.
		----- TRANSISTORS -----
Q301	19A149542P2	Silicon, PNP: sim to Motorola MJD32C.
Q302	19A700076P2	Silicon, NPN: sim to MMBT3904, low profile.
Q401	19A704708P2	Silicon, NPN: sim to NEC 2SC3356.
Q501	19A700076P2	Silicon, NPN: sim to MMBT3904, low profile.
Q701 thru Q705	19A700076P2	Silicon, NPN: sim to MMBT3904, low profile.
		----- RESISTORS -----
R1 and R2	19B801251P510	Metal film: 51 ohms \pm 5%, 1/10 w.
R201	19B800607P180	Metal film: 18 ohms \pm 5%, 1/8 w.
R202	19B800607P270	Metal film: 27 ohms \pm 5%, 1/8 w.
R203	19B800607P100	Metal film: 10 ohms \pm 5%, 1/8 w.
R204	19B800607P101	Metal film: 100 ohms \pm 5%, 1/8 w.
R208	19B800607P151	Metal film: 150 ohms \pm 5%, 1/8 w.
R209	19B801486P101	Metal film: 100 ohms, \pm 5%, 1/2w.
R213	19B800607P331	Metal film: 330 ohms \pm 5%, 1/8 w.
R214	19B800607P150	Metal film: 150 ohms \pm 5%, 1/8 w.
R215	19B800607P331	Metal film: 330 ohms \pm 5%, 1/8 w.
R216	19B800607P270	Metal film: 27 ohms \pm 5%, 1/8 w.
R217	19B800607P101	Metal film: 100 ohms \pm 5%, 1/8 w.

SYMBOL	PART NO.	DESCRIPTION
R218	19B800607P100	Metal film: 10 ohms \pm 5%, 1/8 w.
R219	19B800607P121	Metal film: 120 ohms \pm 5%, 1/8 w.
R223	19B800607P510	Metal film: 51 ohms \pm 5%, 1/8 w.
R224	19B800607P181	Metal film: 180 ohms \pm 5%, 1/8 w.
R225	19B800607P271	Metal film: 270 ohms \pm 5%, 1/8 w.
R301 thru R303	19B800607P100	Metal film: 10 ohms \pm 5%, 1/8 w.
R304	19B800607P470	Metal film: 47 ohms \pm 5%, 1/8 w.
R305	19B800607P103	Metal film: 10K ohms \pm 5%, 1/8 w.
R306	19B800607P222	Metal film: 2.2K ohms \pm 5%, 1/8 w.
R307	19A702931P230	Metal film: 2000 ohms \pm 1%, 200 VDCW, 1/8 w.
R308	19A702931P230	Metal film: 2000 ohms \pm 1%, 200 VDCW, 1/8 w.
R313 and R314	19B800607P100	Metal film: 10 ohms \pm 5%, 1/8 w.
R401	19B800607P330	Metal film: 33 ohms \pm 5%, 1/8 w.
R402	19B800607P102	Metal film: 1K ohms \pm 5%, 1/8 w.
R403	19B800607P104	Metal film: 100K ohms \pm 5%, 1/8 w.
R404	19B800607P561	Metal film: 560 ohms \pm 5%, 1/8 w.
R405	19B800607P510	Metal film: 51 ohms \pm 5%, 1/8 w.
R406	19B800607P151	Metal film: 150 ohms \pm 5%, 1/8 w.
R407	19B800607P104	Metal film: 100K ohms \pm 5%, 1/8 w.
R408	19B800607P100	Metal film: 10 ohms \pm 5%, 1/8 w.
R409	19B800607P222	Metal film: 2.2K ohms \pm 5%, 1/8 w.
R410 and R411	19B800607P472	Metal film: 4.7K ohms \pm 5%, 1/8 w.
R412	19B800607P473	Metal film: 47K ohms \pm 5%, 1/8 w.
R415	19B800607P473	Metal film: 47K ohms \pm 5%, 1/8 w.
R416	19B800607P150	Metal film: 15 ohms \pm 5%, 1/8 w.
R417	19B800607P331	Metal film: 330 ohms \pm 5%, 1/8 w.
R418	19B800607P681	Metal film: 680 ohms \pm 5%, 1/8 w.
R419	19B800607P103	Metal film: 10K ohms \pm 5%, 1/8 w.
R420	19B800607P154	Metal film: 150K ohms \pm 5%, 1/8 w.
R421	19B800607P103	Metal film: 10K ohms \pm 5%, 1/8 w.
R502	19B800607P103	Metal film: 10K ohms \pm 5%, 1/8 w.
R503	19B800607P224	Metal film: 220K ohms \pm 5%, 1/8 w.
R504	19B800607P150	Metal film: 15 ohms \pm 5%, 1/8 w.
R505	19B800607P104	Metal film: 100K ohms \pm 5%, 1/8 w.
R506	19B800607P224	Metal film: 220K ohms \pm 5%, 1/8 w.
R507	19B800607P104	Metal film: 100K ohms \pm 5%, 1/8 w.
R509	19B800607P473	Metal film: 47K ohms \pm 5%, 1/8 w.
R510	19B800607P103	Metal film: 10K ohms \pm 5%, 1/8 w.
R511	19B800607P101	Metal film: 100 ohms \pm 5%, 1/8 w.
R512	19B800607P473	Metal film: 47K ohms \pm 5%, 1/8 w.
R513	19B800607P100	Metal film: 10 ohms \pm 5%, 1/8 w.
R514	19B800607P222	Metal film: 2.2K ohms \pm 5%, 1/8 w.
R515	19B800607P224	Metal film: 220K ohms \pm 5%, 1/8 w.
R516 and R517	19B800607P102	Metal film: 1K ohms \pm 5%, 1/8 w.
R518	19B800607P472	Metal film: 4.7K ohms \pm 5%, 1/8 w.
R601	19A702931P176	Metal film: 604 ohms \pm 1%, 200 VDCW, 1/8 w.
R602	19B800607P223	Metal film: 22K ohms \pm 5%, 1/8 w.
R603	19B800607P104	Metal film: 100K ohms \pm 5%, 1/8 w.
R604	19B800607P470	Metal film: 47 ohms \pm 5%, 1/8 w.
R605	19B800607P104	Metal film: 100K ohms \pm 5%, 1/8 w.

*COMPONENTS, ADDED, DELETED OR CHANGED BY PRODUCTION CHANGES

SYMBOL	PART NO.	DESCRIPTION
R606	19B800607P333	Metal film: 33K ohms $\pm 5\%$, 1/8 w.
R607	19B800607P100	Metal film: 10 ohms $\pm 5\%$, 1/8 w.
R608	19B800607P104	Metal film: 100K ohms $\pm 5\%$, 1/8 w.
R609	19B800607P472	Metal film: 4.7K ohms $\pm 5\%$, 1/8 w.
R610	19B800607P105	Metal film: 1M ohms $\pm 5\%$, 1/8 w.
R611	19B800607P105	Metal film: 1M ohms $\pm 5\%$, 1/8 w.
R612	19B800607P184	Metal film: 180K ohms $\pm 5\%$, 1/8 w.
R701 thru R706	19B800607P102	Metal film: 1K ohms $\pm 5\%$, 1/8 w.
R707 thru R709	19B800607P473	Metal film: 47K ohms $\pm 5\%$, 1/8 w.
R710 thru R712	19B800607P103	Metal film: 10K ohms $\pm 5\%$, 1/8 w.
R713	19B800607P102	Metal film: 1K ohms $\pm 5\%$, 1/8 w.
R714	19B800607P103	Metal film: 10K ohms $\pm 5\%$, 1/8 w.
R715	19B800607P473	Metal film: 47K ohms $\pm 5\%$, 1/8 w.
R716	19B800607P103	Metal film: 10K ohms $\pm 5\%$, 1/8 w.
R722	19B800607P473	Metal film: 47K ohms $\pm 5\%$, 1/8 w.
R723	19B800607P391	Metal film: 390 ohms $\pm 5\%$, 1/8 w.
R724	19B800607P102	Metal film: 1K ohms $\pm 5\%$, 1/8 w.
R725 thru R727	19B800607P273	Metal film: 27K ohms $\pm 5\%$, 1/8 w.
R901	19B800607P121	Metal film: 120 ohms $\pm 5\%$, 1/8 w.
R902	19B800607P331	Metal film: 330 ohms $\pm 5\%$, 1/8 w.
R903	19B800607P150	Metal film: 15 ohms $\pm 5\%$, 1/8 w.
R904	19B800607P331	Metal film: 330 ohms $\pm 5\%$, 1/8 w.
R905	19B800607P151	Metal film: 150 ohms $\pm 5\%$, 1/8 w.
R906	19B800607P181	Metal film: 180 ohms $\pm 5\%$, 1/8 w.
R907	19B800607P271	Metal film: 270 ohms $\pm 5\%$, 1/8 w.
----- INTEGRATED CIRCUITS -----		
U1	19A705537P2	Analog: MMIC, sim to Avantek MSA0886.
U201	19A705927P1	Silicon, bipolar: sim to Avantek MSA-0611.
U202	344A3907P1	Analog: MMIC, sim to Avantek MSA1105.
U203	19A705927P1	Silicon, bipolar: sim to Avantek MSA-0611.
U301	19A704971P8	Voltage Regulator, Positive: sim to Motorola MC78M05CDT.
U302	19A116297P7	Linear: Dual Op Amp; sim to MC4558CD.
U401	19A149944P201	Digital : Prescaler, sim to MC12022A.
U402	19B800902P5	Synthesizer, custom: CMOS, serial input.
U403	19A702293P3	Linear: Dual Op Amp; sim to LM358D.
U501	19A702293P3	Linear: Dual Op Amp; sim to LM358D.
U502	19A702705P4	Digital: Quad Analog Switch/Multiplexer; sim to 4066BM.
U601	19A116297P7	Linear: Dual Op Amp; sim to MC4558CD.
U701	19A703483P302	Digital: Quad 2-Input NAND Gate; sim to 74HC00.
U702	19A703471P320	Digital: 3-Line To 8-Line Decoder; sim to 74HC138.
U705	19A703483P302	Digital: Quad 2-Input NAND Gate; sim to 74HC00.
U901	19A705927P1	Silicon, bipolar: sim to Avantek MSA-0611.
U902	RYT102217	Silicon, bipolar. Prescaler, divide by 2.
U903	19A705927P1	Silicon, bipolar: sim to Avantek MSA-0611.
----- VOLTAGE REGULATORS -----		
VR601 and VR602	19B235029P7	Variable Resistor: 5K, 0.5 W.

**U201 And U203
U901 and U903
19A705927P1**
Silicon Bipolar MMIC

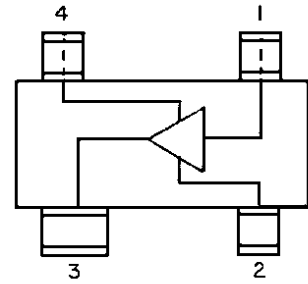

PIN 1. RF INPUT
2. GROUND
3. RF OUTPUT AND BIAS
4. GROUND

**U1
19A705537P2
U202
344A3907P1**
Silicon Bipolar MMIC

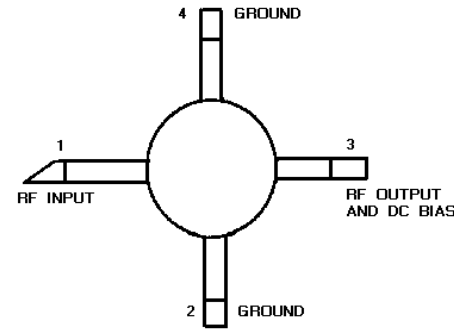

**U301
19A70497188**
+5V Regulator

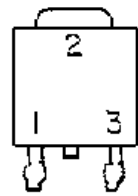

PIN	FUNCTION
1	INPUT
2	GROUND
3	OUTPUT

**U302 & U601
19A116297P7**
Dual Wide Band Op-Amp

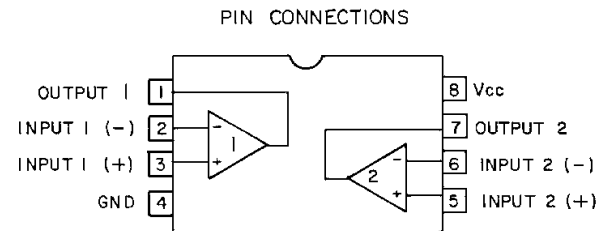

**U902
RYT102217**
Prescaler ÷2

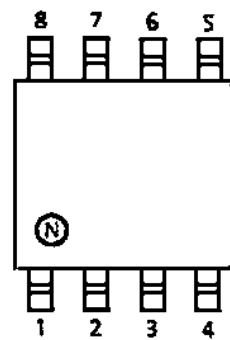

PIN CONNECTION

1. U_s
2. Input
3. Bypass
4. GND
5. GND
6. NC
7. Output
8. NC

**U403, U501
19A702293P3**
Operational Amplifier

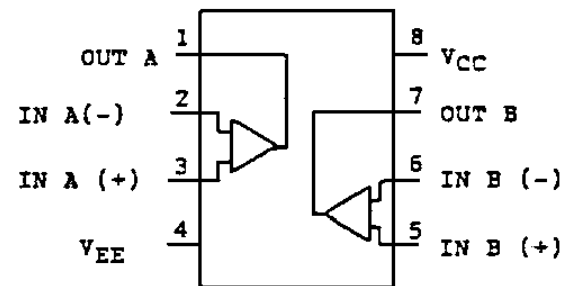

**U401
19A149944P201**
Dual Modulus Prescaler

FUNCTION TABLE		
SW	MC	DIVIDE RATIO
H	H	64
H	L	65
L	H	128
L	L	129

SW: H = V_{cc} L = OPEN
MC: H = 2.0V TO V_{cc}
L = GND TO 0.8V

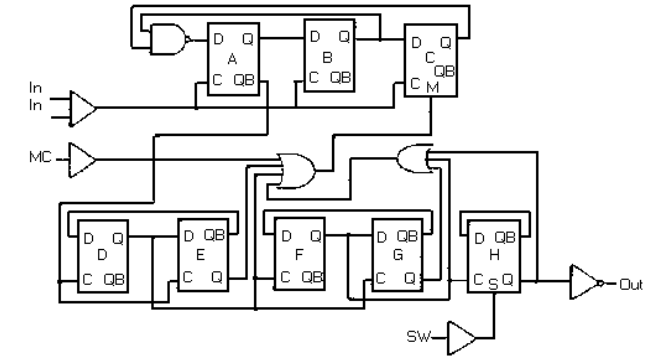

**U402
19B800902P5**
Synthesizer

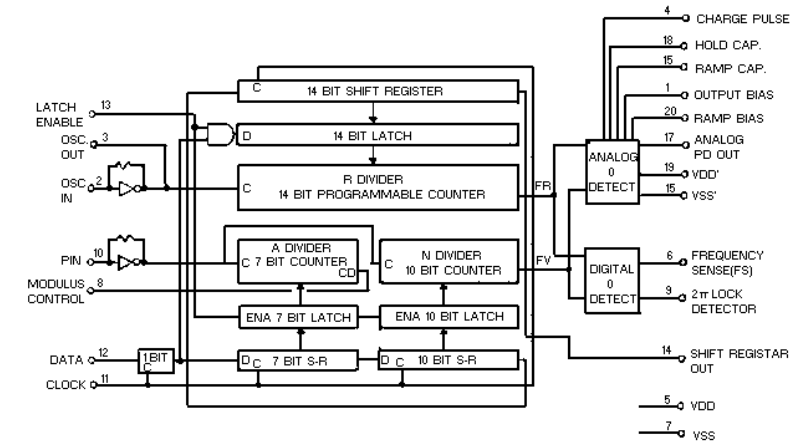
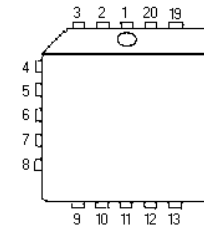

**U502
19A702705P4**
Quad Analog Switch

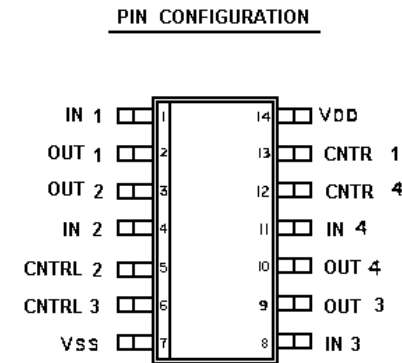

LOGIC DIAGRAM

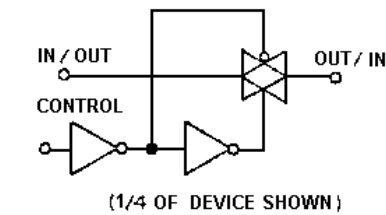

CONTROL	SWITCH
0	OFF
1	ON

U701 & U705
19A703483P302
Quad 2-Input NAND Gate

PIN ASSIGNMENT

A1	1	14	V _{CC}
B1	2	13	B4
Y1	3	12	A4
A2	4	11	Y4
B2	5	10	B3
Y2	6	9	A3
GND	7	8	Y3

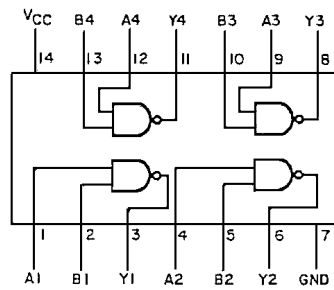

U702
19A703471P120
Address Decoder

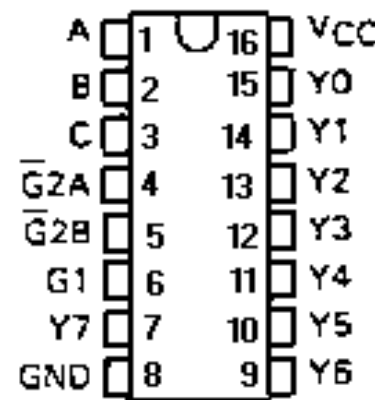
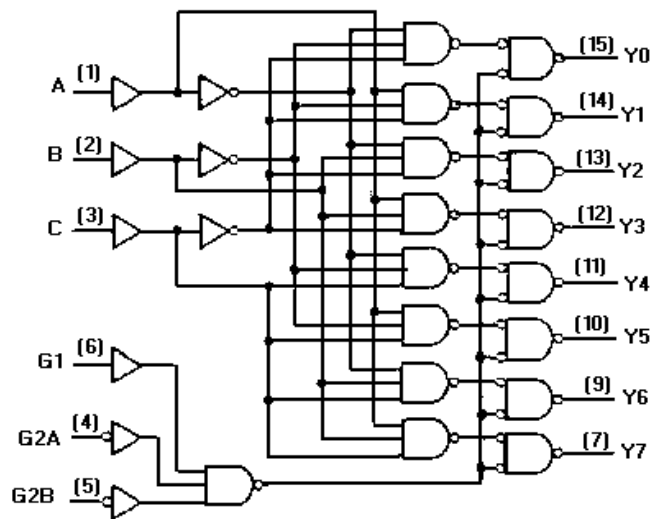

FUNCTION TABLE

ENABLE INPUTS			SELECT INPUTS			OUTPUTS							
G1	G2A	G2B	C	B	A	Y0	Y1	Y2	Y3	Y4	Y5	Y6	Y7
X	H	X	X	X	X	H	H	H	H	H	H	H	H
X	X	H	X	X	X	H	H	H	H	H	H	H	H
L	X	X	X	X	X	H	H	H	H	H	H	H	H
H	L	L	L	L	L	L	H	H	H	H	H	H	H
H	L	L	L	L	H	H	L	H	H	H	H	H	H
H	L	L	L	H	L	H	H	L	H	H	H	H	H
H	L	L	H	L	L	K	H	H	K	L	H	H	H
H	L	L	H	L	H	H	H	H	H	H	L	H	H
H	L	L	H	H	L	H	H	H	H	H	H	L	H
H	L	L	H	H	H	H	H	H	H	H	H	L	H

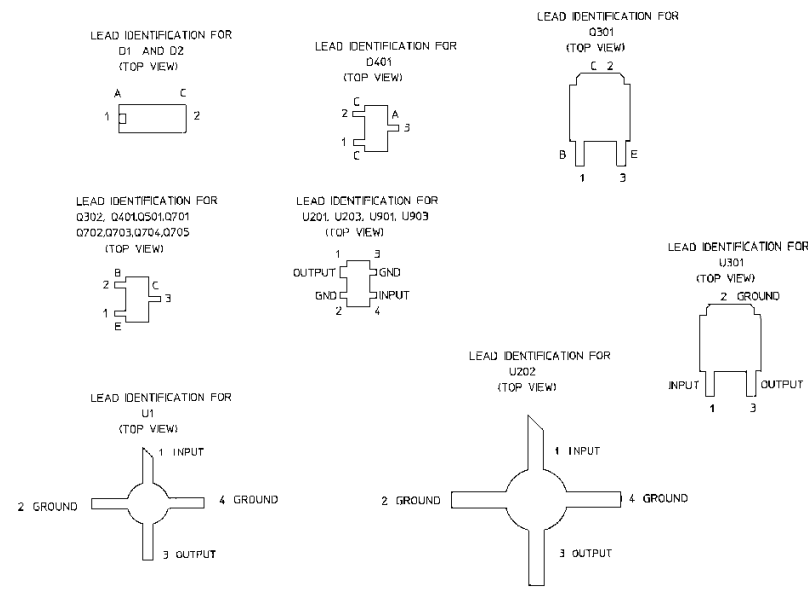
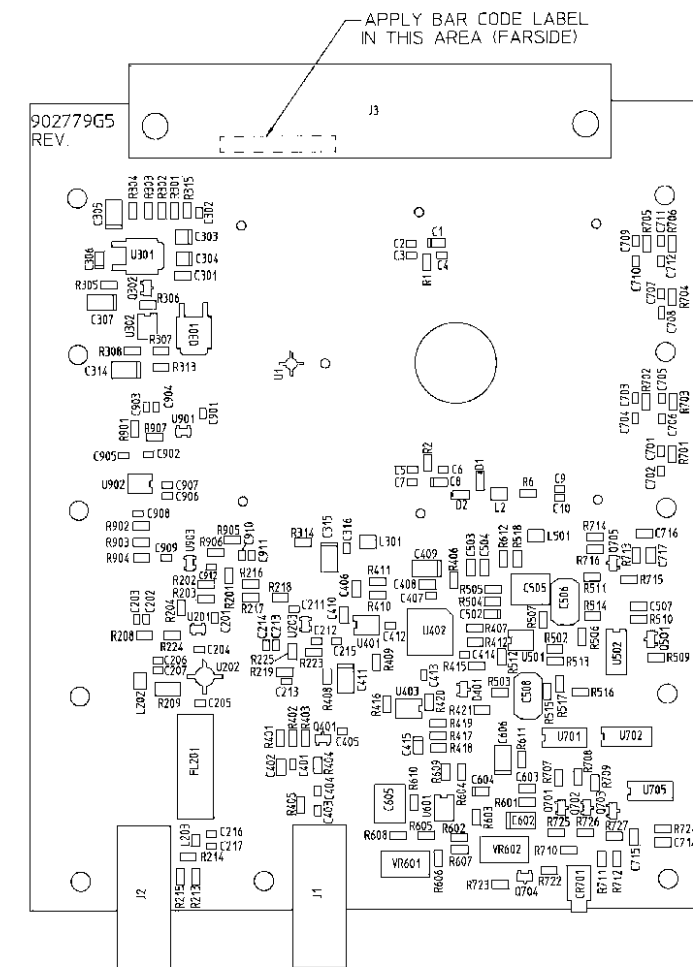

800 MHz TRANSMITTER SYNTHESIZER BOARD
19D902779G5

(19D902779, Sh. 3, Rev. 0)

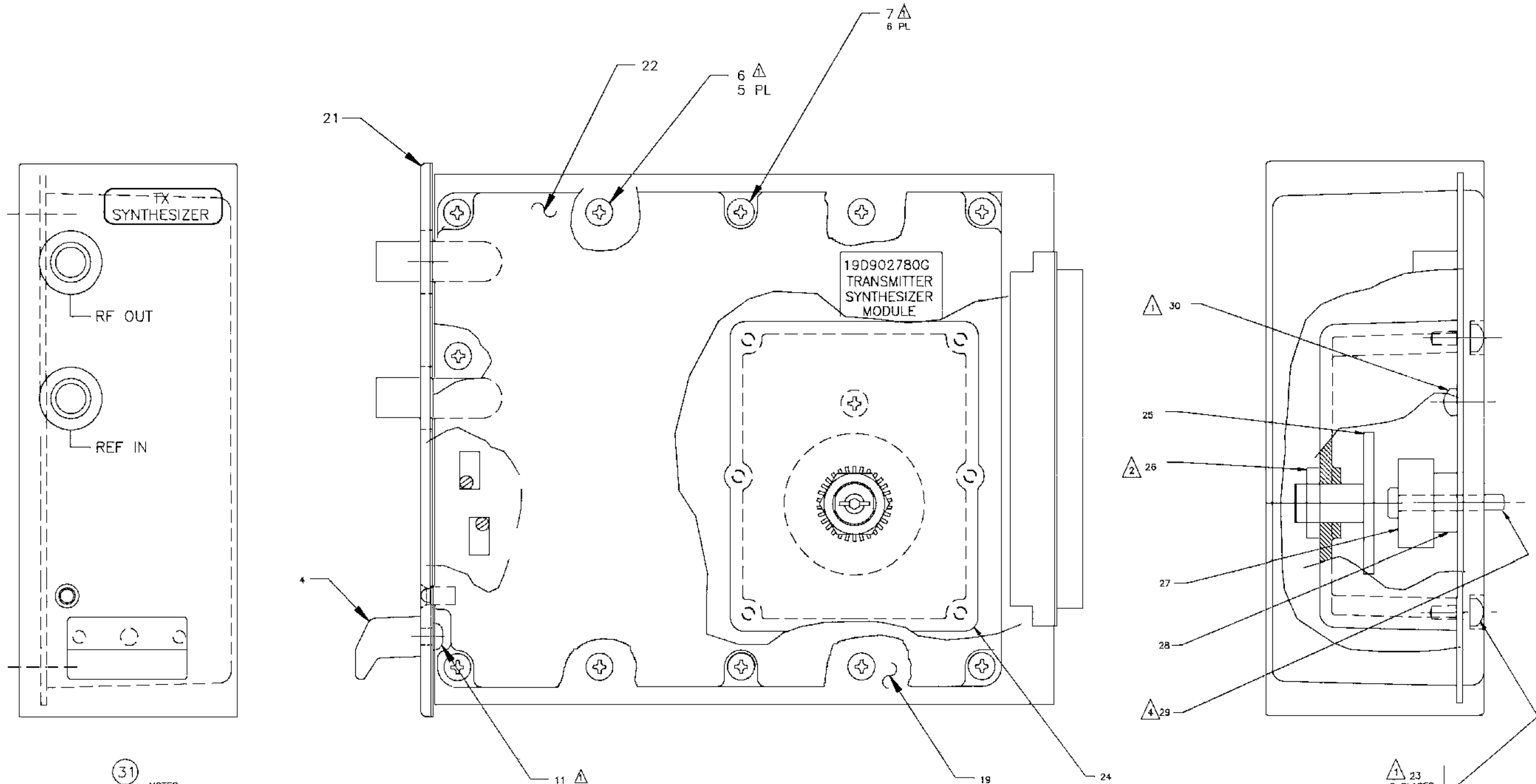

- 31 NOTES:
- ▲ TORQUE SCREWS, ITEMS 6, 7 AND 23, TO 15.5 ± 1.3 INCH POUNDS.
TORQUE SCREW, ITEM 11, TO 20 ± 1.3 INCH POUND.
TORQUE SCREW, ITEM 30, TO 6 ± 1 INCH POUNDS.
 - ▲ TIGHTEN TUNING NUT, ITEM 26 SO THAT TORQUE ON TUNING SCREW, ITEM 25 IS 100 IN. OZ. AT MIDDLE OF TUNING RANGE WITH POINTS ON TUNING NUT BETWEEN RAISED SERRATIONS ON COVER, ITEM 24.
 - ▲ TORQUE SCREW, ITEM 29 TO 3 INCH POUNDS AND LOCK THREADS USING ADHESIVE PER EGE PROCESS P7C-EA147. THEN TRIM SCREW FLUSH TO .050 MAX. ABOVE SURFACE OF ITEM 21.

▲ 23
6 PLACES
TO MOUNT
ITEM 24

800 MHz TRANSMITTER SYNTHESIZER MODULE
19D902780G5

(19D902780, Sh. 2, Rev. 1)

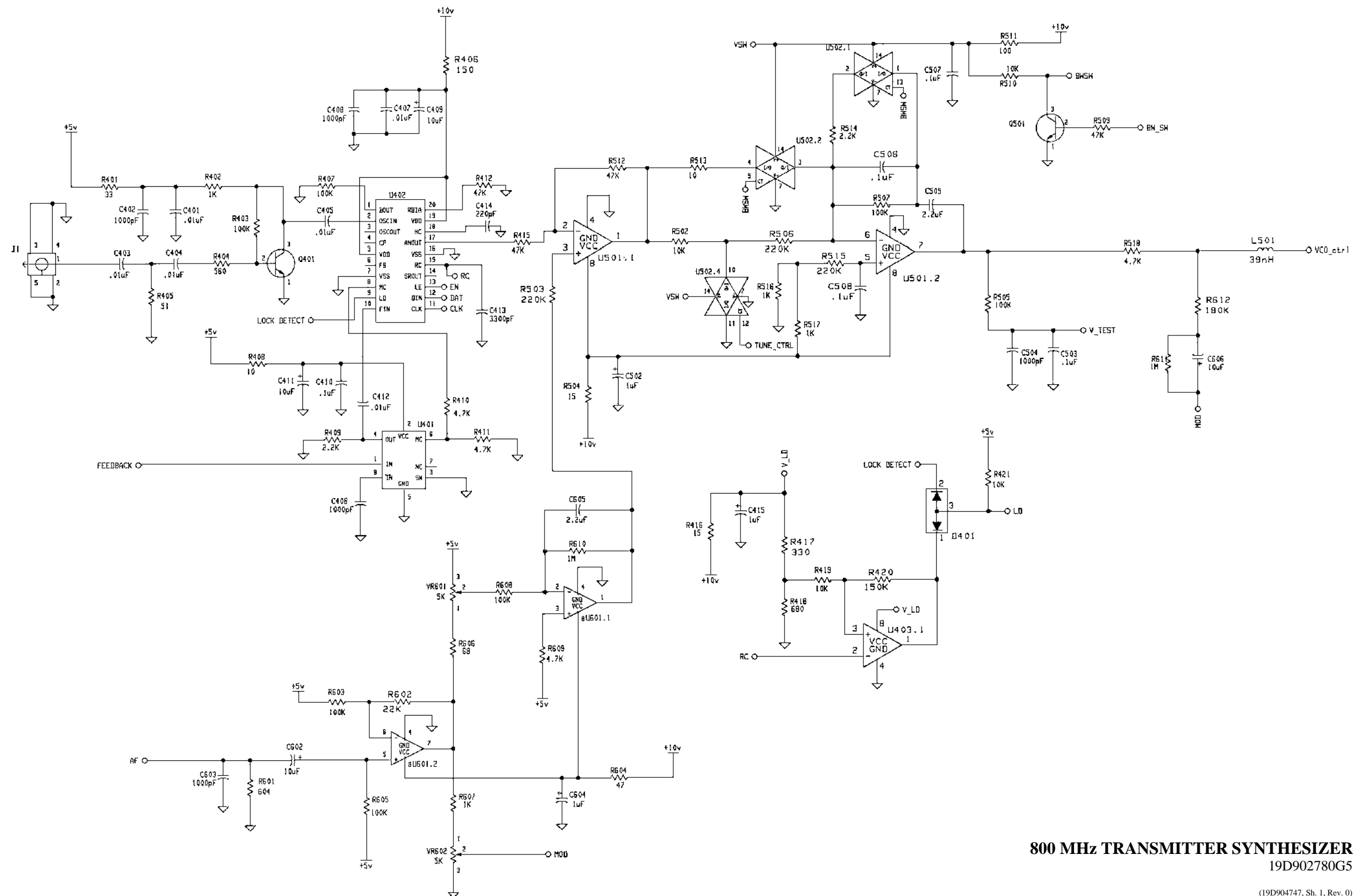

800 MHz TRANSMITTER SYNTHESIZER

19D902780G5

(19D904747, Sh. 1, Rev. 0)

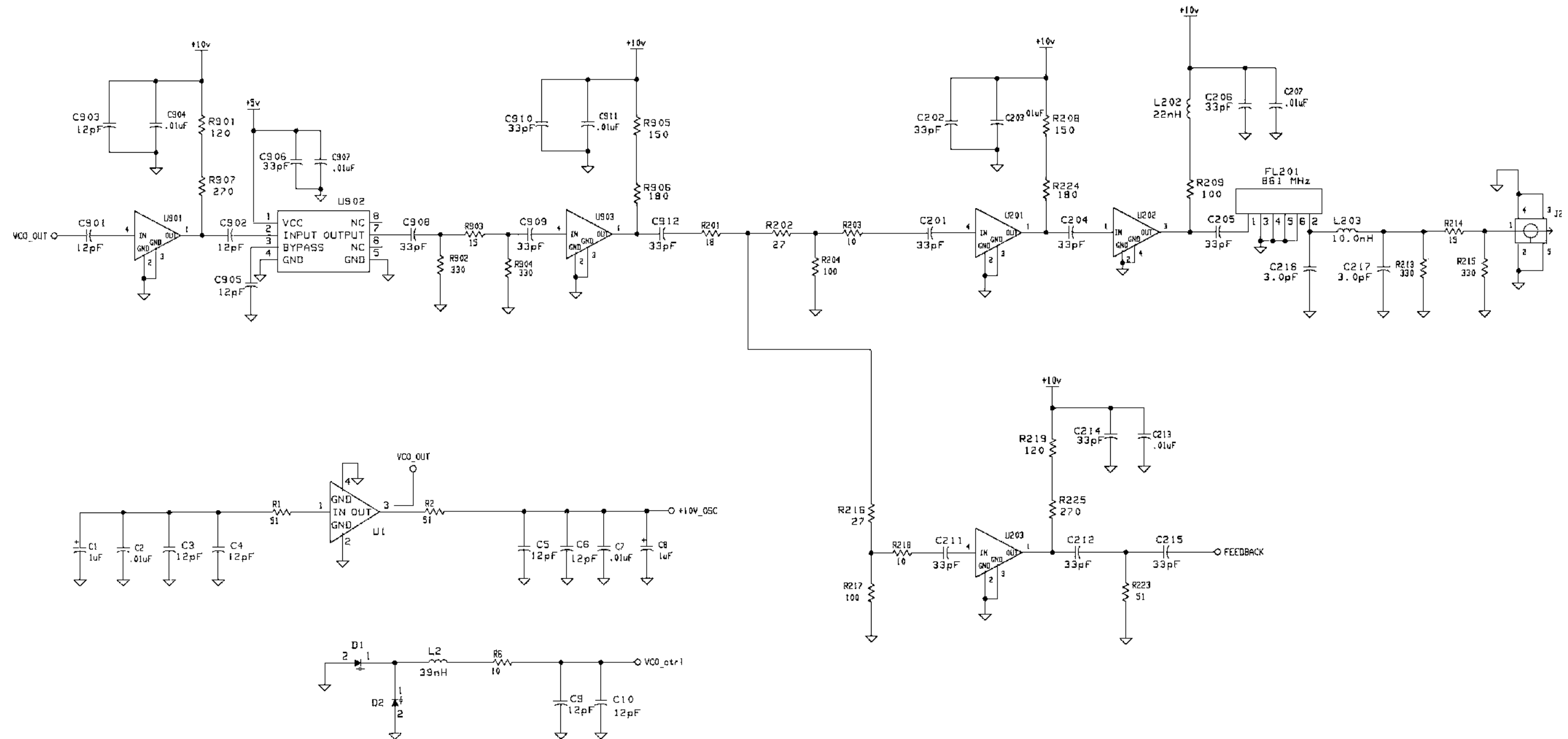

800 MHz TRANSMITTER SYNTHESIZER
19D902780G5

(19D904747, Sh. 2, Rev. 0)

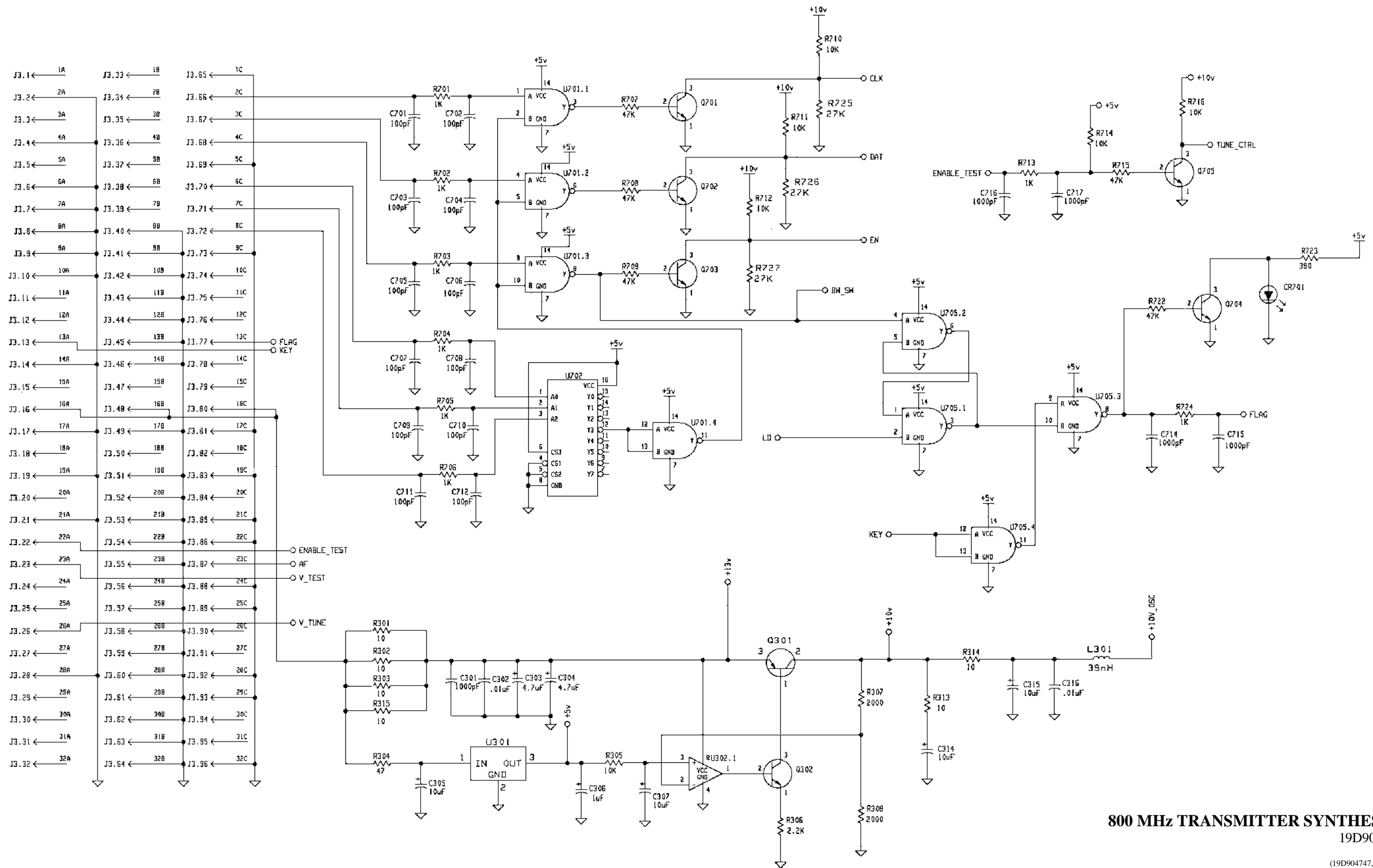

800 MHz TRANSMITTER SYNTHESIZER
19D902780G5

(19D904747, Sh. 3, Rev. 0)