



MAINTENANCE MANUAL

851-870 MHz, 100 WATT POWER AMPLIFIER

19D901841G3

TABLE OF CONTENTS

	<u>Page</u>
SPECIFICATIONS	Front Cover
DESCRIPTION	1
CIRCUIT ANALYSIS	1
Power Amplifier	1
Power Control	1
INTERCONNECTION DIAGRAM	2
OUTLINE DIAGRAMS	
Power Amplifier	4
Power Control Board	6
Buffer Amplifier Assembly	10
SCHEMATIC DIAGRAMS	
Power Amplifier	5
Power Control Board	7
Power Amplifier	10
Power Amplifier Fan Assembly	11
PARTS LIST	8

SPECIFICATIONS*

POWER OUTPUT	100 Watts (adjustable from 50 watts to rated power output).
FCC FILING	AXATR-329
SPURIOUS AND HARMONIC EMISSION (per EIA RS-152-B Par. 4)	-13dBm output (conducted) -13dBm (Radiated)
DUTY CYCLE	Continuous
RF OUTPUT IMPEDANCE	50 ohms

*These specifications are intended primarily for the use of the serviceman. Refer to the appropriate Specification Sheet for the complete specifications.

WARNING

Although the highest DC voltage supplied to the transmitter is + 24VDC, high currents may be drawn under short circuit conditions. These currents can heat metal objects such as tools, rings, watchbands, etc., enough to cause burns. Be careful when working near energized 24 Volt circuits!

High level RF energy in the transmitter Power Amplifier assembly can cause RF burns upon contact. **KEEP AWAY FROM THESE CIRCUITS WHEN THE TRANSMITTER IS ENERGIZED!**



Ericsson GE Mobile Communications Inc.
Mountain View Road • Lynchburg, Virginia 24502

DESCRIPTION

The 19D901841G3 800 MHz power amplifier assembly used in MASTR III station applications uses seven RF power devices to provide a maximum of 100 watts output power. R11 on the Power Control Board (19D901803G3) provides adjustment of the output power over a 3 dB range (50W to 100W).

The power amplifier assembly consists of an RF board with all the amplifier stages and an output detector, a power control board, and an isolator. A driver amp board is also located on the P.A. cover.

Supply voltage from the system board is connected to TB1 and decoupled by C6.

CIRCUIT ANALYSIS

DRIVER AMP

The driver amplifier board is located in a shielded enclosure mounted to the fan cover of the power amplifier assembly. This driver amp amplifies the +10dB (10mW) signal from the Tx synthesizer to +20 dB (100mW).

The function of the 800 MHz Buffer Amplifier is to increase the power level from the MASTR III Exciter module to a level sufficient to drive the 100 Watt MASTR II Power Amplifier.

The circuit is powered from the T/R shelf's +13 V supply. This is connected to the board at J3.6, and powers the 8V regulator, U1. The output of U1 is switched to the amplifier circuit via Q2, which is turned on by a +5V signal applied to J3.2.

A +10 dBm RF signal is supplied at J2, and this drives the MMIC, U2, via the attenuator network R9-R11. The output of U2 drives the GaAs FET transistor, Q3. The nominal +20 dBm output of U3 appears at J1.

POWER AMPLIFIER

The driver amp output (100mW) is coupled to the amplifier input connector J1 by a 50 ohm coaxial cable. L1, C1, C2, and the base microstrip form the input matching circuit for Q1. Control voltage is applied to Q1 through a collector feed network consisting of C3, C4, and L3.

Interstage matching between Q1 and Q2 is provided by L4, L5, C6, C8, C9, and C10. Control voltage is applied to Q2 through a collector feed network consisting of Z1, C11-C13,

and L7. The output of Q2 is matched to the input of Q3 by L8, L9, C30, C15, and the base microstrip.

Supply voltage for Q3 is applied through collector feed network Z2, C16-C18, and L11. The output of Q3 is matched to 50 ohms by microstrip W2. This output is applied to a Wilkinson divider consisting of microstrips W4 and W5. R1 provides isolation between the signal paths.

Input matching for Q4 and Q5 is provided by microstrips W8 and W9. Supply voltage is applied to Q4 and Q5 by collector feed networks Z3, Z4, C20-C25, L12, and L13. Microstrips W12 and W13 provide output matching.

The outputs of Q4 and Q5 are summed by a Wilkinson combiner consisting of W16, W17, and R3. The output of the combiner is connected to pin 1 of circulator U1.

WARNING

The RF Power Transistors used in the transmitter contain Beryllium Oxide, a TOXIC substance. If the ceramic, or other encapsulation is opened, crushed, broken, or abraded, the dust may be hazardous if inhaled. Use care in replacing transistors of this type.

NOTE

This amplifier is not field repairable. Should service become necessary, the complete power amplifier assembly must be returned to the factory for servicing.

A directional coupler, W19, and detector CR1 provide a voltage, proportional to the power out, to the power control.

POWER CONTROL

On the Power Control Board, the voltage from the detector is compared to a stable DC reference voltage in a high gain comparator, U2A. The comparator drives a DC amplifier, Q4 and pass transistor Q6 that supplies control voltage to the RF board.

Thermistor RT1 is connected to the PA heatsink and, by controlling the operation of Q2 and Q3, provides a power cut-back for ambient temperatures that exceed 70 degrees centigrade. Conduction of Q3 gradually decreases the power set voltage applied to Q4. The DC reference voltage is provided by Q1, U3, R17-19, and C5.

In other special applications of this power control board, U2-B, CR1, and Q5 provide a low power alarm. U1 is used to select one of four individually adjustable power levels.

In a MASTR III station application, the binary input select lines of U1 are hardwired to select power level 0 (PLO), which is adjusted by R11. R2, R5, and R8 will have no effect on the PA output power and should be set fully CCW.

R1, R4, R7, and R10 are factory adjusted values.

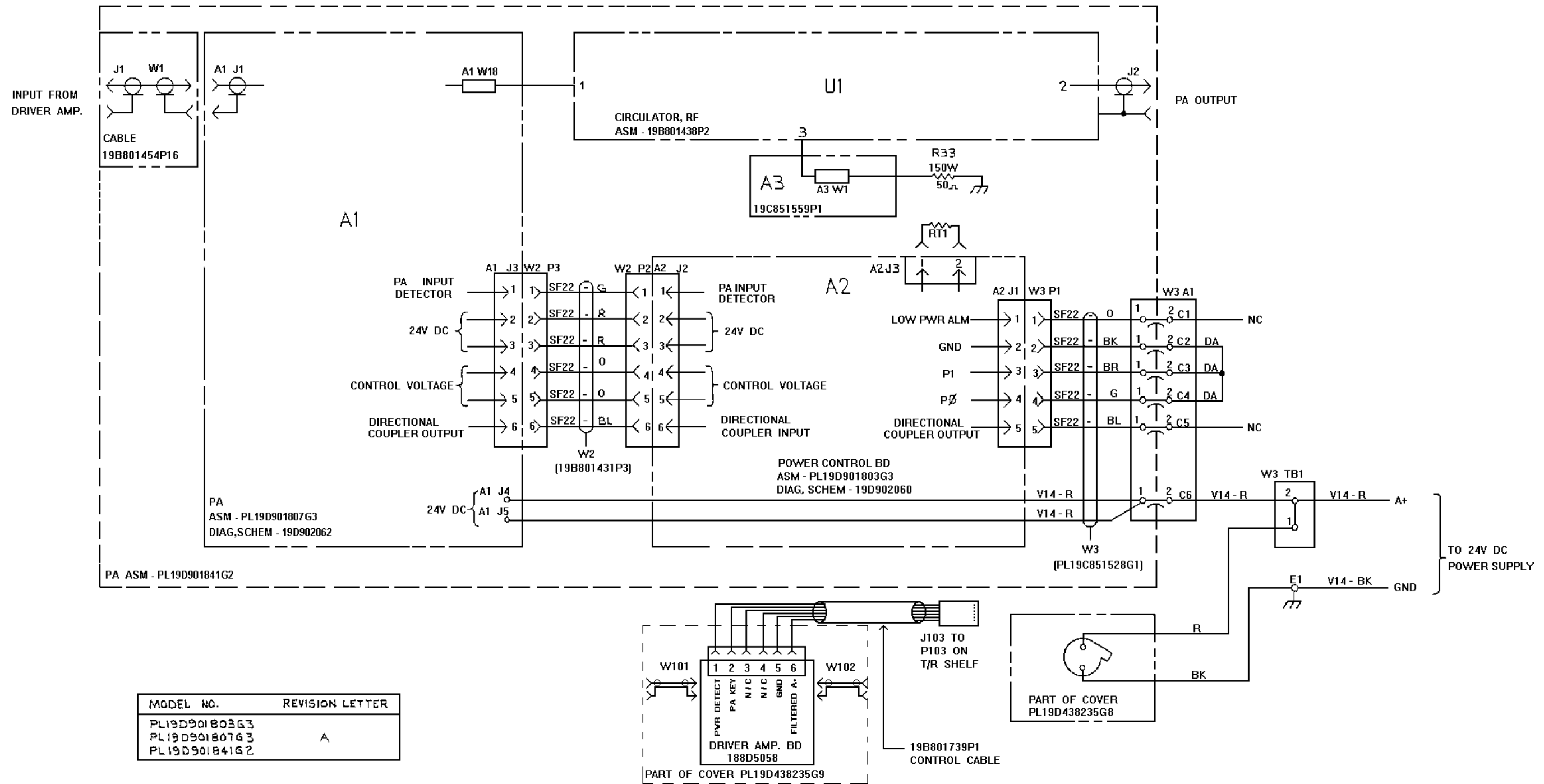

**POWER AMPLIFIER
19D901841G3**

(19D902064, Sh. 1, Rev. 1)

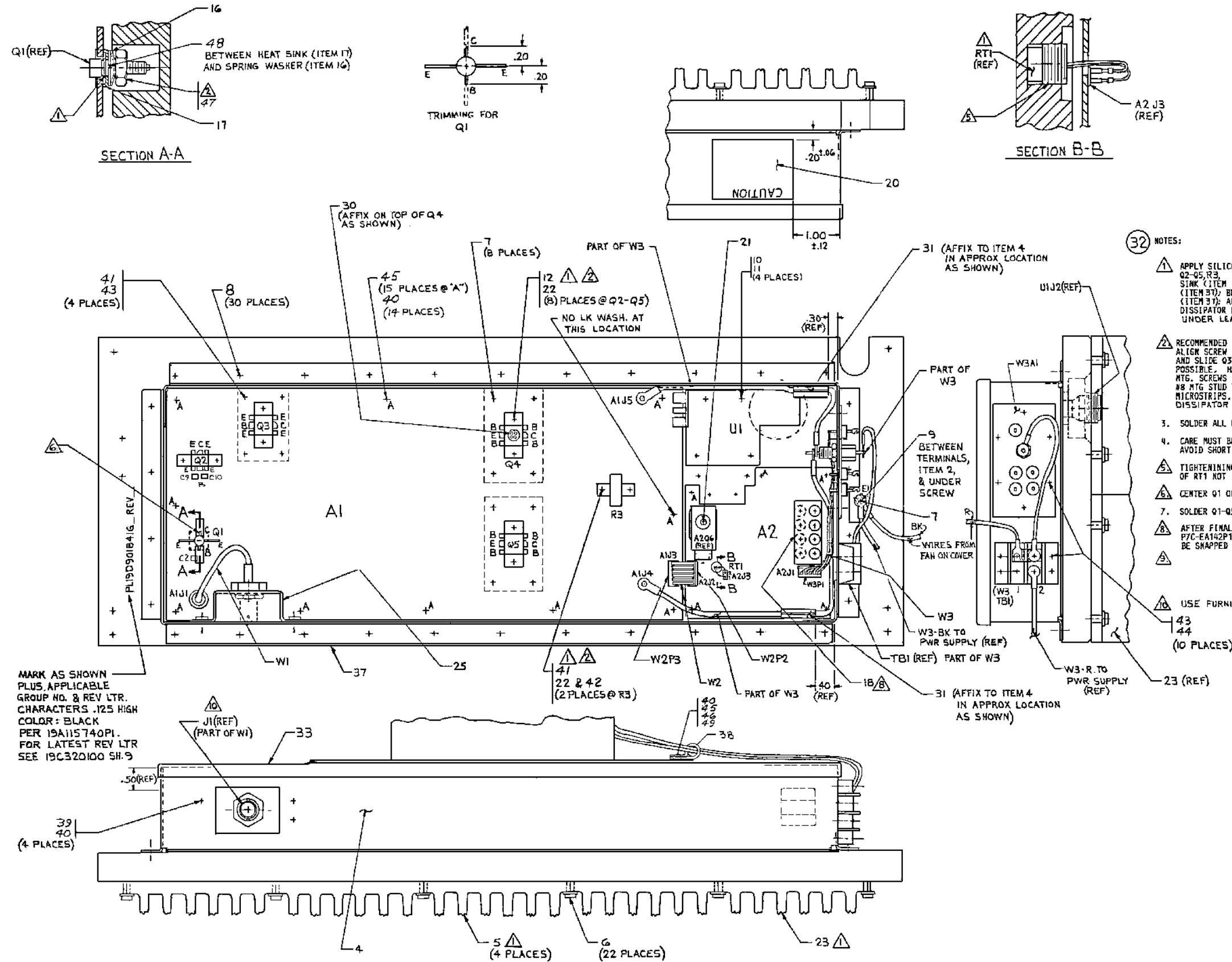

**POWER AMPLIFIER
19D901841G3**

(19D901841, Sh. 2, Rev.)

COMPONENT SIDE

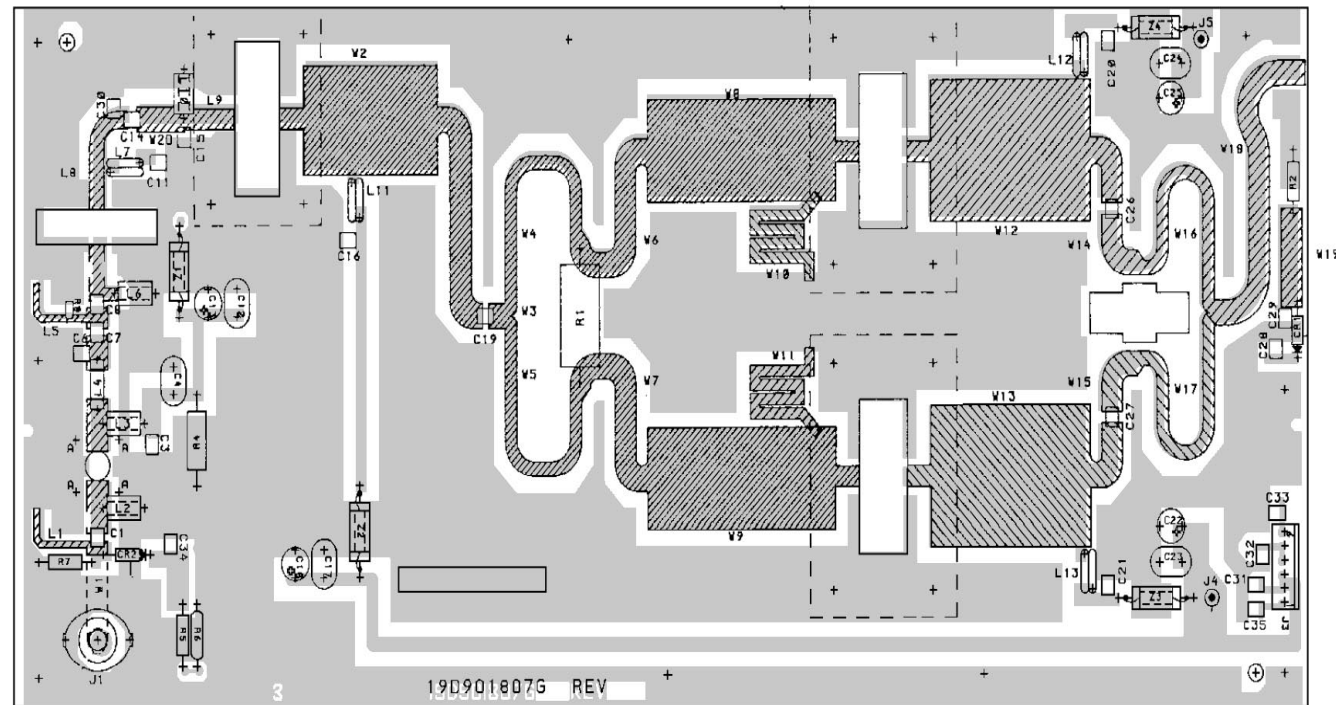

SOLDER SIDE

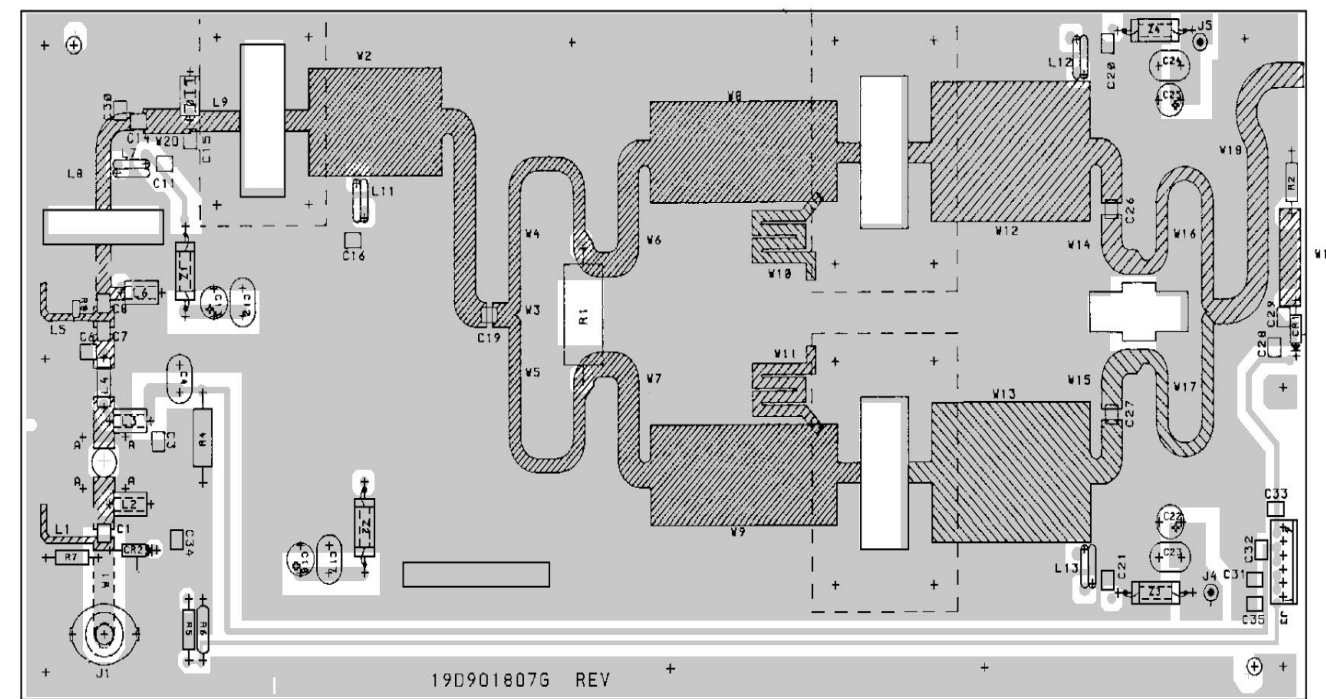

15 NOTES:

1. SOLDER ALL ELECTRICAL CONNECTIONS.
2. COMPONENT LEADS TO PROTRUDE .060 MAX. BELOW SOLDER SIDE OF BOARD.
3. INDICATES FRONT OF COMPONENT AUTO-INSERTION MACHINES.
4. THE FOLLOWING ITEMS ARE MOS DEVICES REQUIRING SPECIAL CARE PER 19A701294: U1.

POWER AMPLIFIER
19D901841G3

(19D901807, Sh. 2, Rev. 6)
(19D705468, Sh. 1, Rev. 3)
(19A705468, Sh. 2, Rev. 1)

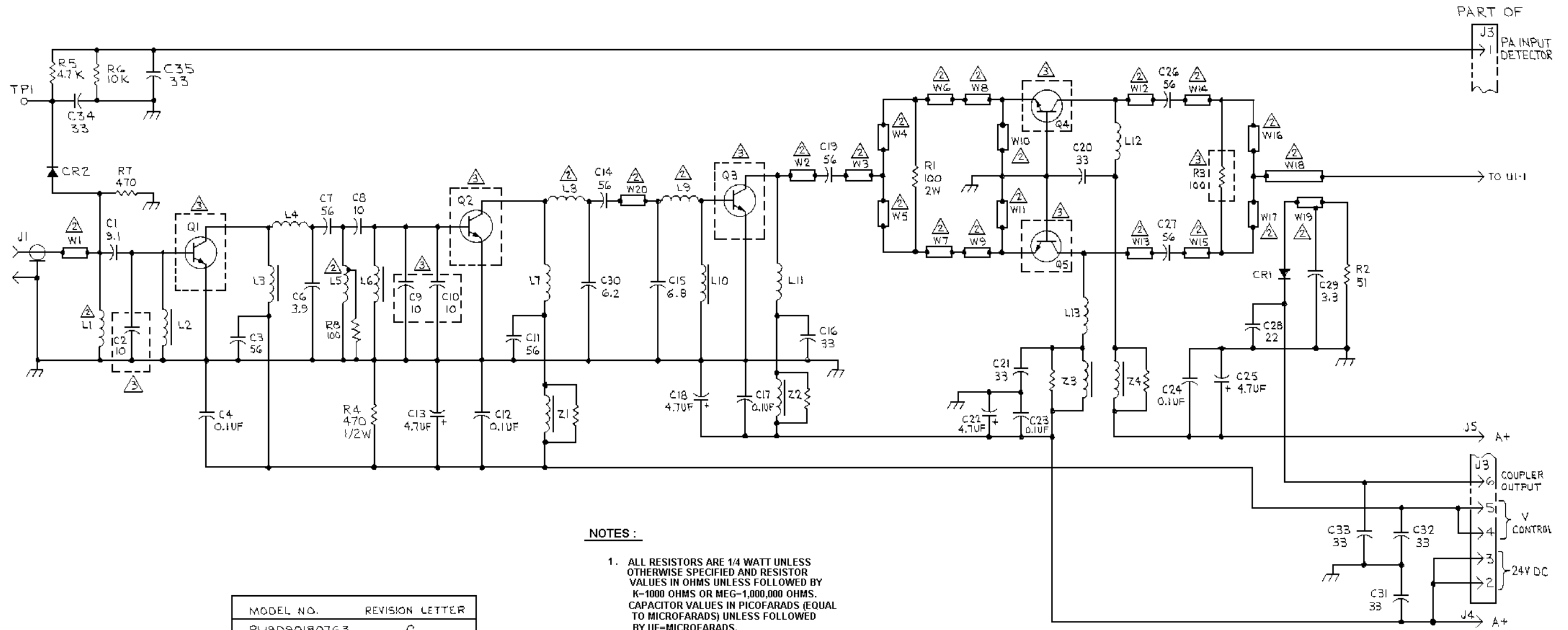

MODEL NO.	REVISION LETTER
PL13D90180T6 3	C

NOTES :

1. ALL RESISTORS ARE 1/4 WATT UNLESS OTHERWISE SPECIFIED AND RESISTOR VALUES IN OHMS UNLESS FOLLOWED BY K=1000 OHMS OR MEG=1,000,000 OHMS. CAPACITOR VALUES IN PICO FARADS (EQUAL TO MICROFARADS) UNLESS FOLLOWED BY UF=MICROFARADS.

- Ⓜ PART OF PWB.
- Ⓝ PART OF NEXT HIGHER ASM.

**POWER AMPLIFIER
19D901841G3**

(19D902062, Rev. 4)

COMPONENT SIDE

SOLDER SIDE

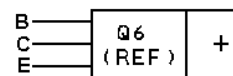
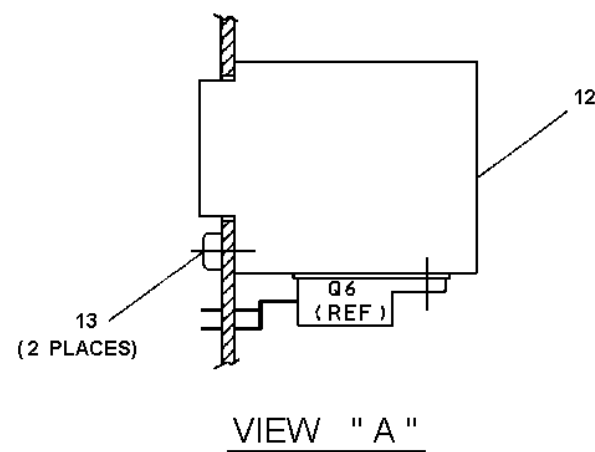
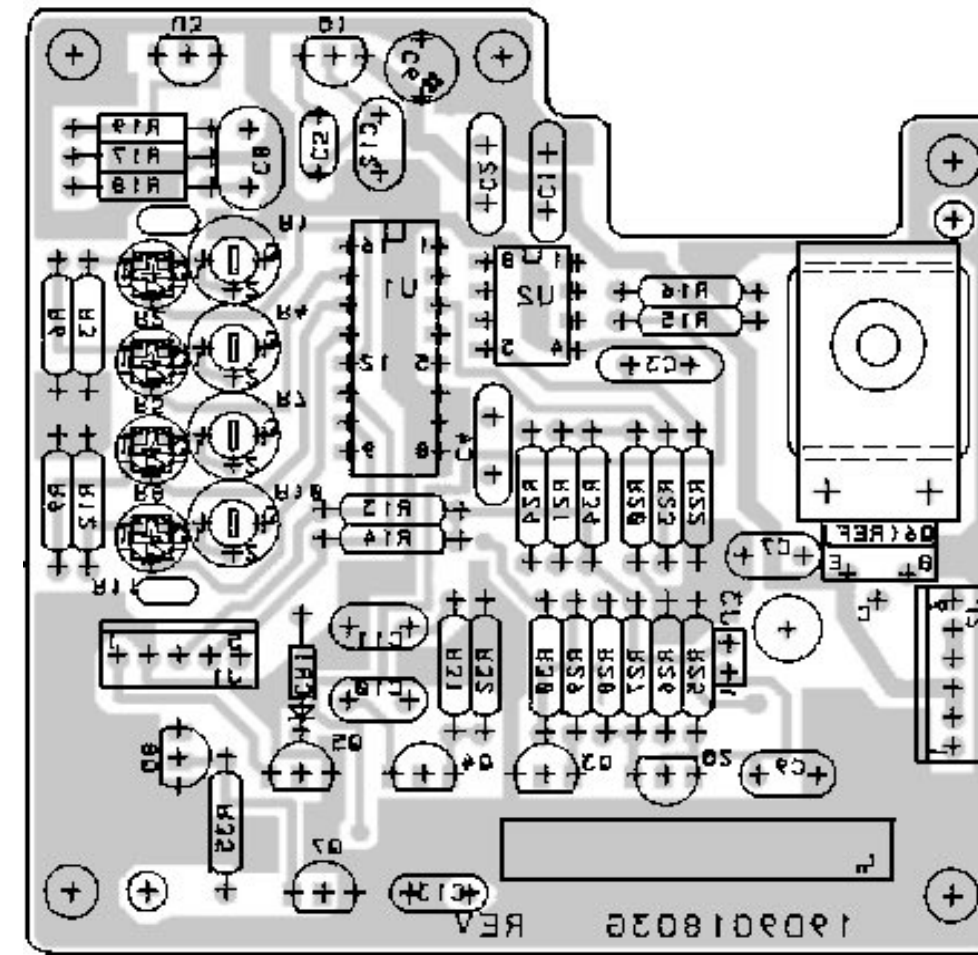
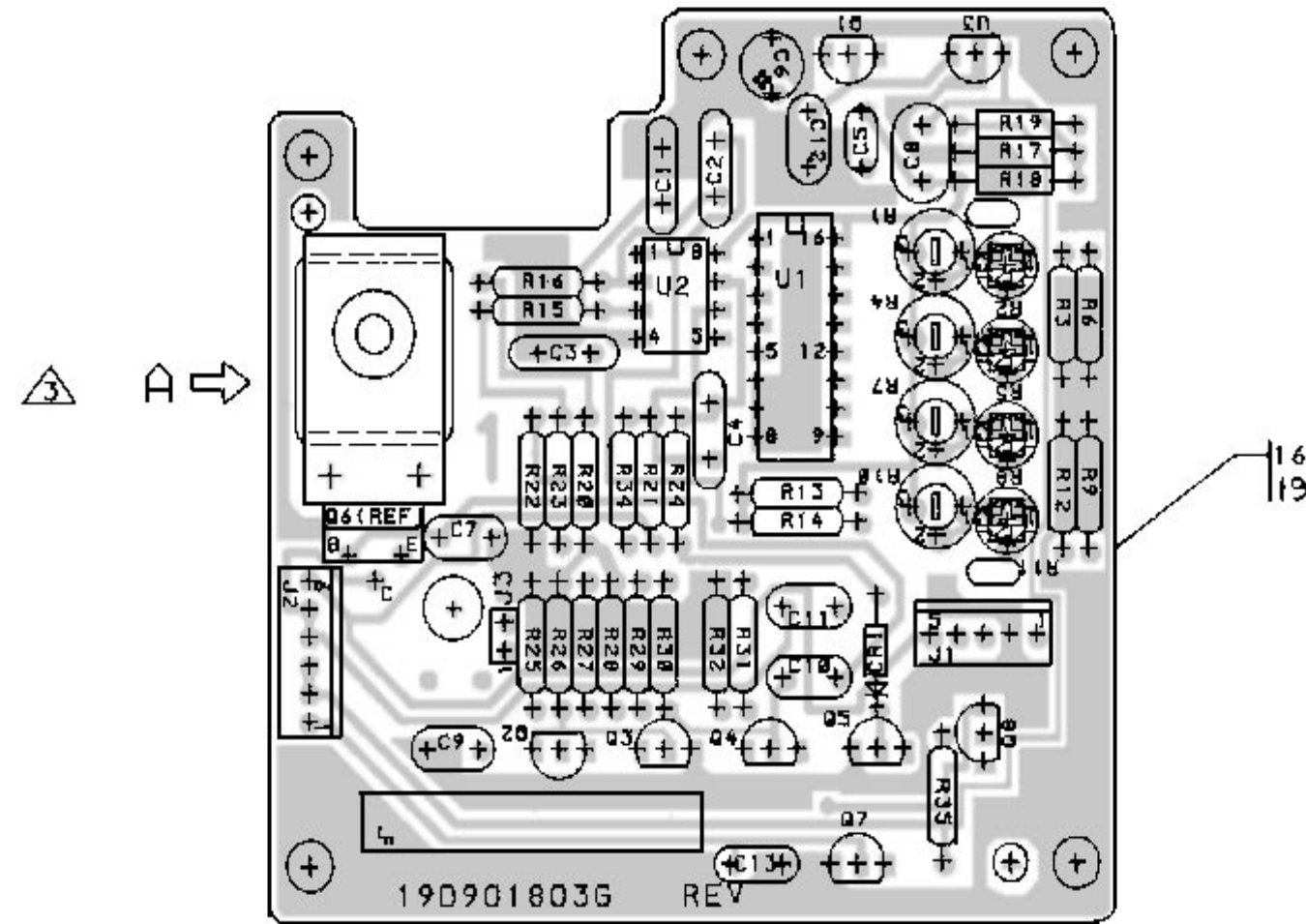

LEAD IDENTIFICATION FOR Q1-Q5, Q7 AND Q8

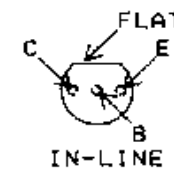

TOP VIEW

NOTE: CASE SHAPE IS DETERMINING FACTOR FOR LEAD IDENTIFICATION.

LEAD IDENTIFICATION FOR U3

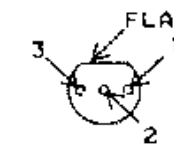

TOP VIEW

NOTE: CASE SHAPE IS DETERMINING FACTOR FOR LEAD IDENTIFICATION.

POWER AMPLIFIER
19D901803G3

(19D901803, Sh. 1, Rev. 1)
(19D902059, Component Side, Rev. 1)
(19D902059, Solder Side, Rev. 1)

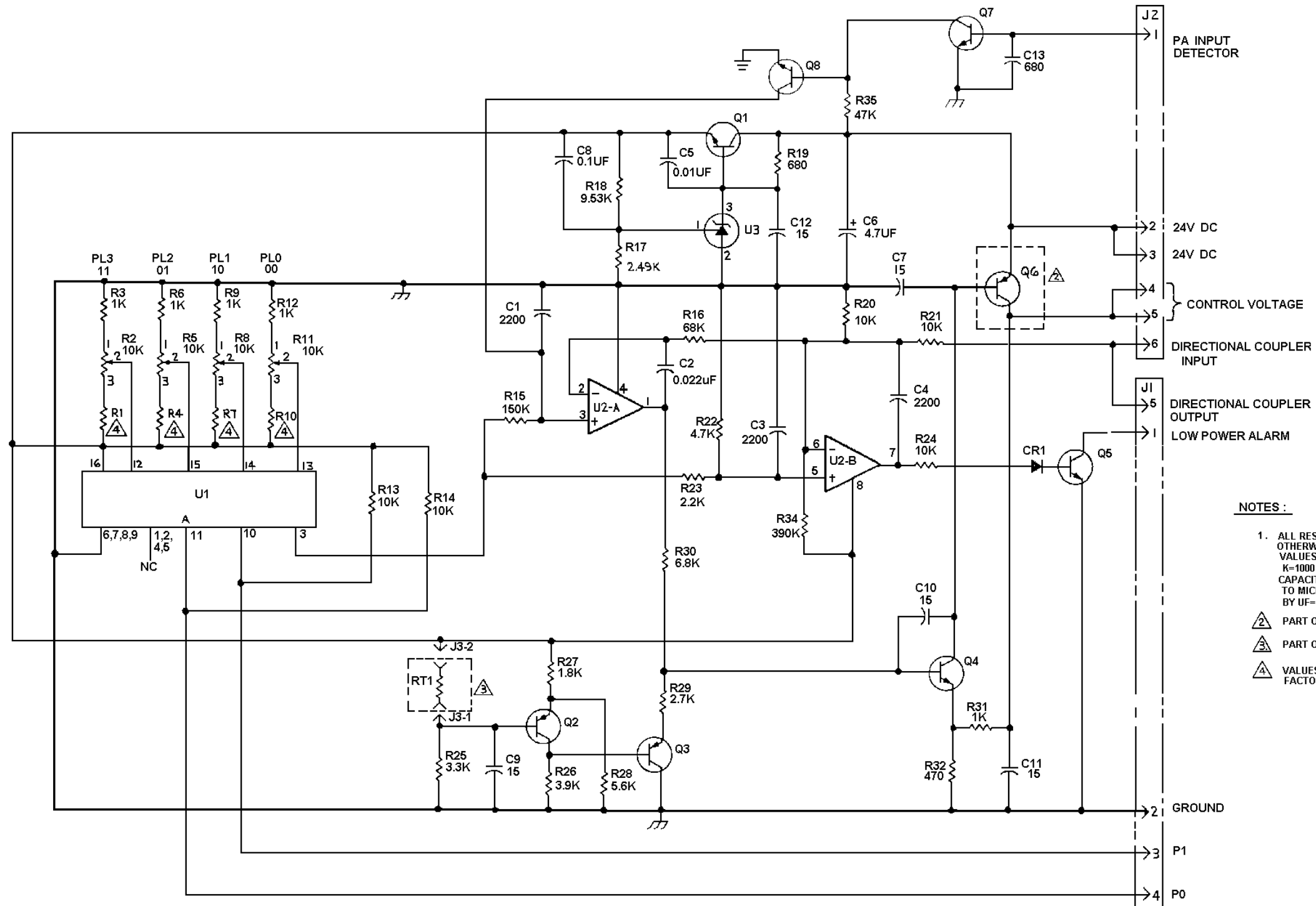

NOTES :

1. ALL RESISTORS ARE 1/4 WATT UNLESS OTHERWISE SPECIFIED AND RESISTOR VALUES IN OHMS UNLESS FOLLOWED BY K=1000 OHMS OR MEG=1,000,000 OHMS. CAPACITOR VALUES IN PICO FARADS (EQUAL TO MICROFARADS) UNLESS FOLLOWED BY UF=MICROFARADS.
2. PART OF HEAT SINK ASM PL19B801427
3. PART OF NEXT HIGHER ASM.
4. VALUES OF R1, R4, R7 & R10 ARE FACTORY ADJUSTED.

MODEL NO.	REVISION LETTER
PL19D901803G3	B

POWER CONTROL BOARD
19D901803G3

851-870 MHz 100 WATT POWER AMPLIFIER
19D901841G3
ISSUE 2

SYMBOL	PART NUMBER	DESCRIPTION
A1		Power Amplifier Board 19D901807G3
		----- CAPACITORS -----
C1	19A702232P12	Ceramic: 9.1 pF ±5%, 50 VDCW.
C3	19A702232P31	Ceramic: 56 pF ±5%, 50 VDCW.
C4	19A702250P113	Polyester: 0.1 μF ±10%, 50 VDCW.
C6	19A702232P3	Ceramic: 3.9 pF .25 pF, 50 VDCW.
C7	19A702232P31	Ceramic: 56 pF ±5%, 50 VDCW.
C8	19A705108P13	Mica Chip: 10 pF %5, 500 VDCW, temp coef 0 + 200 PPM/C.
C9 and C10	19A705108P13	Mica Chip: 10 pF %5, 500 VDCW, temp coef 0 + 200 PPM/C.
C11	19A702232P31	Ceramic: 56 pF ±5%, 50 VDCW.
C12	19A702250P113	Polyester: 0.1 μF ±10%, 50 VDCW.
C13	19A701534P6	Tantalum: 4.7 μF ±20%, 35 VDCW.
C14	19A702232P31	Ceramic: 56 pF ±5%, 50 VDCW.
C15	19A705108P9	Mica: 6.8 pF .25 pF, 500 VDCW.
C16	19A705108P25	Mica Chip: 33 pF ±5%, 500 VDCW, temp coef 0 + 50 PPM/C.
C17	19A702250P113	Polyester: 0.1 μF ±10%, 50 VDCW.
C18	19A701534P6	Tantalum: 4.7 μF ±20%, 35 VDCW.
C19	19A702232P31	Ceramic: 56 pF ±5%, 50 VDCW.
C20 and C21	19A705108P25	Mica Chip: 33 pF ±5%, 500 VDCW, temp coef 0 + 50 PPM/C.
C22	19A701534P6	Tantalum: 4.7 μF ±20%, 35 VDCW.
C23 and C24	19A702250P113	Polyester: 0.1 μF ±10%, 50 VDCW.
C25	19A701534P6	Tantalum: 4.7 μF ±20%, 35 VDCW.
C26 and C27	19A702232P31	Ceramic: 56 pF ±5%, 50 VDCW.
C28	19A702232P21	Ceramic: 22 pF ±5%, 50 VDCW.
C29	19A702232P1	Ceramic: 3.3 pF .25 pF, 50 VDCW.
C30	19A705108P8	Mica: 6.2 pF .25 pF, 500 VDCW.
C31 thru C35	19A705108P25	Mica Chip: 33 pF ±5%, 500 VDCW, temp coef 0 + 50 PPM/C.
		----- DIODES -----
CR1 and CR2	19A700047P3	Silicon: 100 mW; sim to 1N6263.
		----- JACKS -----
J1	19A700049P2	Connector, receptacle; 500 VDCW maximum; sim to NTT-1058.
J2		PART OF U1
J3	19A704852P32	Printed wire, two part: 6 contacts, sim to Molex 22-29-2061.
J4 and J5	19A134263P1	Contact, electrical: sim to Selectro 229-1082-00-0-590.
		----- INDUCTORS -----
L1		PART OF PWB
L2	19A701091G1	Coil.
L3	19A701091G1	Coil.
L4	19A701006P7	Strap.

SYMBOL	PART NUMBER	DESCRIPTION
L5		PART OF PWB
L6	19A701091G1	Coil.
L7	19A136533P2	Coil.
L8 and L9		PART OF PWB
L10	19A701091G1	Coil.
L11 thru L13	19A136533P2	Coil.
		----- TRANSISTORS -----
Q1	19A703479P1	N Channel, field effect. sim to RF 2060.
Q2	19A703480P4	Silicon, NPN: Sim to MRF-891.
Q3	19A705125P1	Silicon, NPN: Sim to MRF-895.
Q4 and Q5	19A705125P2	Silicon, NPN: Sim to MRF-898.
		----- RESISTORS -----
R1	19A700111P39	Composition: 100 ohms ±5%, 2w.
R2	19A700106P32	Composition: 51 ohms ±5%, 1/4w.
R3	19A143832P1	Power: 100 ohms ±5%, 75w.
R4	19A700113P55	Composition: 470 ohms ±5%, 1/2 w.
R5	H212CRP247C	Deposited carbon: 4.7K ohms ±5%, 1/4 w.
R6	H212CRP310C	Deposited carbon: 10K ohms ±5%, 1/4 w.
R7	19A700106P55	Composition: 470 ohms ±5%, 1/4 w.
R8	19B800607P101	Metal film: 100 ohms ±5%, 1/8 w.
		----- INTEGRATED CIRCUITS -----
U1	19B802097P2	Circulator: 120 Watts.
		----- CABLES -----
W1 thru W20		PART OF PWB
		----- FILTER -----
Z1	19A701091G2	Filter.
Z2 thru Z4	19A701092G1	Filter.
	19B801426P2	Plate Support.
	19B801426P1	Plate Support.
A2		Power Control Board 19D901803G3
		----- CAPACITORS -----
C1	19A700233P9	Ceramic: 2200 pF, ±20%, 50 VDCW.
C2*	T644ACP322K	Polyester: 0.022 μF ±10%, 50 VDCW.
C3 and C4	19A700233P9	Ceramic: 2200 pF, ±20%, 50 VDCW.
C5	T644ACP310K	Polyester: .010 μF ±10%, 50 VDCW.
C6	19A701534P6	Tantalum: 4.7 μF ±20%, 35 VDCW.
C7	19A701624P12	Ceramic, disc: 15 pF ±5%, 500 VDCW, temp coef 0 PPM 30.
C8	19A702250P113	Polyester: 0.1 μF ±10%, 50 VDCW.
C9 thru C12	19A701624P12	Ceramic, disc: 15 pF ±5%, 500 VDCW, temp coef 0 PPM 30.
C13	19A700233P6	Ceramic: 680 pF ±20%, 50 VDCW.
		----- DIODES -----
CR1	19A700028P1	Silicon: 75 mA, 75 PIV; sim to 1N4148.

SYMBOL	PART NUMBER	DESCRIPTION
		----- JACKS -----
J1	19A704852P31	Connector: 5 contacts; sim to Molex 22-29-2051.
J2	19A704852P32	Printed wire, two part: 6 contacts, sim to Molex 22-29-2061.
J3	19A700072P1	Printed wire: 2 contacts rated @ 2.5 amps; sim to Molex 22-03-2021.
		----- TRANSISTORS -----
Q1	19A700023P2	Silicon, NPN: sim to 2N3904.
Q2 and Q3	19A700022P2	Silicon, PNP: sim to 2N3906.
Q4 and Q5	19A700023P2	Silicon, NPN: sim to 2N3904.
Q6	19A700055P1	Silicon, PNP. (Included with Heat Sink Assembly 19B801427G4).
Q7 and Q8	19A700023P2	Silicon, NPN: sim to 2N3904.
		----- RESISTORS -----
R1	19A134248P4	Variable, cermet, 4 turns: 25K ohms ±10%, 1/2 w; sim to Bourns 3339P-1-253.2 w; sim to Bourns 3339P-1-253.
R2	19B800779P10	Variable: 10K ohms 2±5%, 100 VDCW, .3 watt
R3	H212CRP210C	Deposited carbon: 1K ohms ±5%, 1/4 w.
R4	19A134248P4	Variable, cermet, 4 turns: 25K ohms ±10%, 1/2 w; sim to Bourns 3339P-1-253.2 w; sim to Bourns 3339P-1-253.
R5	19B800779P10	Variable: 10K ohms 2±5%, 100 VDCW, .3 watt
R6	H212CRP210C	Deposited carbon: 1K ohms ±5%, 1/4 w.
R7	19A134248P4	Variable, cermet, 4 turns: 25K ohms ±10%, 1/2 w; sim to Bourns 3339P-1-253.2 w; sim to Bourns 3339P-1-253.
R8	19B800779P10	Variable: 10K ohms 2±5%, 100 VDCW, .3 watt
R9	H212CRP210C	Deposited carbon: 1K ohms ±5%, 1/4 w.
R10	19A134248P4	Variable, cermet, 4 turns: 25K ohms ±10%, 1/2 w; sim to Bourns 3339P-1-253.2 w; sim to Bourns 3339P-1-253.
R11	19B800779P10	Variable: 10K ohms 2±5%, 100 VDCW, .3 watt
R12	H212CRP210C	Deposited carbon: 1K ohms ±5%, 1/4 w.
R13 and R14	H212CRP310C	Deposited carbon: 10K ohms ±5%, 1/4 w.
R15	H212CRP415C	Deposited carbon: 0.15M ohms ±5%, 1/4 w.
R16	H212CRP368C	Deposited carbon: 68K ohms ±5%, 1/4 w.
R17	19A701250P239	Metal film: 2490 ohms ±1%, 250 VDCW, 1/4 watt.
R18	19A701250P295	Metal film: 9.53K ohms ±1%, 1/4 w.
R19	H212CRP168C	Deposited carbon: 680 ohms ±5%, 1/4 w.
R20 and R21	H212CRP310C	Deposited carbon: 10K ohms ±5%, 1/4 w.
R22	H212CRP247C	Deposited carbon: 4.7K ohms ±5%, 1/4 w.
R23	H212CRP222C	Deposited carbon: 2.2K ohms ±5%, 1/4 w.
R24	H212CRP310C	Deposited carbon: 10K ohms ±5%, 1/4 w.
R25	H212CRP233C	Deposited carbon: 3.3K ohms ±5%, 1/4 w.
R26	H212CRP239C	Deposited carbon: 3.9K ohms ±5%, 1/4 w.
R27	H212CRP218C	Deposited carbon: 1.8K ohms ±5%, 1/4 w.
R28	H212CRP256C	Deposited carbon: 5.6K ohms ±5%, 1/4 w.
R29	H212CRP227C	Deposited carbon: 2.7K ohms ±5%, 1/4 w.
R30	H212CRP268C	Deposited carbon: 6.8K ohms ±5%, 1/4 w.

SYMBOL	PART NUMBER	DESCRIPTION
R31	H212CRP210C	Deposited carbon: 1K ohms ±5%, 1/4 w.
R32	H212CRP147C	Deposited carbon: 470 ohms ±5%, 1/4 w.
R33	19A143832P	Power: 50 ohms ±5%, 150 watts (Used with A3).
R34	H212CRP439C	Deposited carbon: 0.39M ±5%, 1/4 w.
R35	H212CRP347C	Deposited carbon: 47K ohms ±5%, 1/4 w.
		----- THERMISTOR -----
RT1	19A702176G2	Thermistor: 40K ohms ±20%.
		----- INTEGRATED CIRCUITS -----
U1	19A700029P36	Digital: Single 8-Channel Multiplexer; sim to 4051B.
U2	19A701789P2	Linear: Dual Op Amp; sim to LM358.
U3	19A702939P2	Linear: Adjustable Shunt Regulator; sim to TL431CLP.
		----- MISCELLANEOUS -----
12	19B801427G4	Heat Sink.
13	19A702364P305	Machine screw: TORX DRIVE, M3-5 x 5.
		PA FAN ASSEMBLY 19D438235G9
2	19B234884G1	Fan Plate.
4	5493477P10	Fan Guard.
10	19B209268P1	Solderless Terminal.
11	19D901846G1	Cover
12	N402P7B6	Plain Washer.
13	5493477P7	Fan, Axial.
17	N80P13009B6	Machine Screw: No. 4-40 x 3/8.
18	N402P37B6	Plain Washer.
14	N404P13B6	Lockwasher: No. 6.
20	7141225P3	Nut, Hex.
25	19B801529G4	Cable.
26	19B801739P1	Cable, Control.
30	19A702364P306	Screw, Machine.
31	19A702364P408	Screw, Machine.
		BUFFER AMPLIFIER ASSEMBLY 188D5058G1
		----- CAPACITORS -----
C1	19A705205P12	Tantalum: 0.33 μF, ±20%, 25 VDCW.
C2	19A705205P2	Tantalum: 1.0 μF, ±20%, 10 VDCW.
C3	19A702052P5	Ceramic: 1000 pF, 50 VDCW, temp coef 0+30 PPM/°C.
C4	19A702236P52	Ceramic: 120 pF, 50 VDCW, temp coef 0+30 PPM/°C.
C5	19A702236P13	Ceramic: 3.3 pF 50 VDCW, temp coef 0+30 PPM/°C.
C6 and C7	19A702236P52	Ceramic: 120 pF, 50 VDCW, temp coef 0+30 PPM/°C.
C8	19A702236P13	Ceramic: 3.3 pF 50 VDCW, temp coef 0+30 PPM/°C.
C9	19A702236P52	Ceramic: 120 pF, 50 VDCW, temp coef 0+30 PPM/°C.
C10	19A702236P34	Ceramic: 22 pF, 50 VDCW, temp coef 0+30 PPM/°C.
		----- JACKS -----
J1 and J2	19A705512P1	Connector, RF: Male; sim to AMP 221111-1.
J3	19A704852P32	Connector: 6 pin .
		----- TRANSISTORS -----
Q1	19A700076P2	Silicon, NPN; sim to MMBT3904.

SYMBOL	PART NUMBER	DESCRIPTION
Q2	19A149542P2	Silicon, PNP: sim to MJD32C-1.
Q3	19A705924P1	FET; sim to Panasonic 2SK690.
Q4*	19A700076P2	Silicon, NPN; sim to MMBT3904.
Q5*	19A700059P2	Silicon, PNP: Low profile; sim to MMBT3906.
----- RESISTORS -----		
R1	19B800607P100	Metal Film: 10 ohms, ±5%, 1/8w.
R5 thru R7 R8	19B800607P103	Metal Film: 10K ohms, ±5%, 1/8w.
R9	19B800607P222	Metal Film: 2.2K ohms, ±5%, 1/8w.
R9	19B800607P121	Metal Film: 120 ohms, ±5%, 1/8w.
R10	19B800607P510	Metal Film: 51 ohms, ±5%, 1/8w.
R11	19B800607P121	Metal Film: 120 ohms, ±5%, 1/8w.
R12 and R13 R14	19B800607P270	Metal Film: 27 ohms, ±5%, 1/8w.
R14	19B800607P220	Metal Film: 22 ohms, ±5%, 1/8w.
R15*	19B800607P470 19B801251P180	Metal Film: 47 ohms, ±5%, 1/8w. OR Metal Film: 18 ohms, ±5%, 1/8w.
R16 and R17 R18*	19B800607P103	Metal Film: 10K ohms, ±5%, 1/8w.
R18*	19B800607P180	Metal Film: 18 ohms, ±5%, 1/8w.
R19*	19B800607P472	Metal Film: 4.7K ohms, ±5%, 1/8w.
R20*	19B800607P122	Metal Film: 1.2K ohms, ±5%, 1/8w.
R21*	19B800607P562	Metal Film: 5.6K ohms, ±5%, 1/8w.
----- INTERGRATED CIRCUITS -----		
U1	19A704971P10	Voltage Regulator: 8V; sim to MC78M08CDT.
U2	19A705926P1	MMIC: sim to Minicircuits MAR-45M.
----- CABLES -----		
W1	19A705075P1	Cable Assembly.
W2	19B801431P3	Cable.
W3	19C851528G1	Cable Assembly. Includes:
C1 thru C5 C6	5493392P7	Ceramic, feed thru: 1000 pF -0 +100%, 500 VDCW.
	19A116708P1	Ceramic: 0.01 µF -0 +100%, 500 VDCW, rated 20 amps; sim to Erie 327050X5W0103P.ps; sim to Erie 327050X5W0103P.
2	19B801425P1	Plate.
3	7139898P3	Nut, hex, brass: No. 1/4-28.
P1	19A700041P31	Shell.
----- MISCELLANEOUS -----		
2	19C301087P1	Terminal board.
3	19A704779P26	Contacts: 22-30 AWG; sim to Molex 08-55-0101, Qty of 10.
4	7143961P1	Bus bar: sim to Kulka No. 600.
6	19B209268P113	Terminal, solderless: sim to AMP 2-34835-4.
18	19B209268P115	Terminal: Ring Tongue, sim to AMP 34852.
30	N80P13006B6	Machine screw: Pan head, Phillips; No. 8-32 x 3/8"
35	344A3805P1	Contact: Crimp Type, sim to AMP 350650-1.
36	344A3804P1	Connector Cap.
W4	19B801454P16	Cable Assembly.

SYMBOL	PART NUMBER	DESCRIPTION
----- MISCELLANEOUS -----		
4	19B801424G1	Frame.
5	19B226212G1	Heat sink.
6	19B209103P410	Tap screw, hex head: No. 8-32 x 5/8.
7	19B201074P308	Tap screw, Phillips POZIDRIV: No. 6-32 x 1/2.
8	19B209103P306	Tap screw, hex head: No. 6-32 x 3/8.
9	N403P13B6	Lockwasher: No. 6.
10	N81P9012	Machine screw.
11	N414P11	Lockwasher, internal tooth: No. 4.
12	N44P9006B6	Machine screw, fillister head.
16	5492178P2	Washer, spring tension: sim to Wallace Barnes 375-20.
17	19A148323P1	Heat Sink.
18	19C851552P1	Power Limiter Guide.
20	NP280071	Nameplate. (CAUTION).
21	19B201074P320	Tap screw, Phillips POZIDRIV: No. 6-32 x 1-1/4.
22	N405P5B6	Lock Washer.
23	19B226212G5	Heat Sink
25	19A705097G2	Connector Support Assembly
30	19A705329P1	Temperature indicator: sim to Tempil Division of Big Three Industries Cat. No. BU-175/79. Industries Cat. No. BU-1X/78.
31	19A116552P3	Cable clip: sim to Richco KKC-4.
37	19B801423G3	Plate.
38	19A701863P13	Cable clip.
39	N80P13004B6	Screw, machine: Pan head; No. 6-32 x 1/4".
40	N404P13B6	Lockwasher, internal tooth: No. 6.
41	N80P9005B6	Machine screw, pan head, steel, No. 4-40UNC x 5/16".
42	N402P5B6	Washer: narrow, steel.
43	N404P11B6	Loackwasher, internal tooth, No. 4.
44	7141225P2	Nut, Hex: 4-40.
45	N80P13006B6	Machine screw: Pan head, Phillips; No. 8-32 x 3/8"
46	N402P7B6	Flatwasher, narrow: No. 6.
47	N210P15B6	Nut, hex: No. 8-32.
48	N402P8B6	Flatwasher, steel: No. 8.
49	7141225P3	Hex Nut: No. 6-32.
51	19D438235G9	Fan Assembly.
53	7776570P10	Connector Adapter

PRODUCTION CHANGES

Changes in the equipment to improve performance or to simplify circuits are identified by a "Revision Letter", which is stamped after the model number of the unit. The revision stamped on the unit includes all previous revisions. Refer to the Parts List for the descriptions of parts affected by these revisions.

REV. A - BUFFER AMPLIFIER ASSEMBLY 188D5058G1

To minimize variations in the output power level, Q4, Q5 and R18 thru R21 added. R15 was 33 Ohms and changed to 47 Ohms (19B800607P470).

REV. B - POWER CONTROL BOARD 19D901803G3

To reduce transmit rise time of power amplifier to reduce overshoot. C2 was 19A700223P9 ceramic 2200 pF.

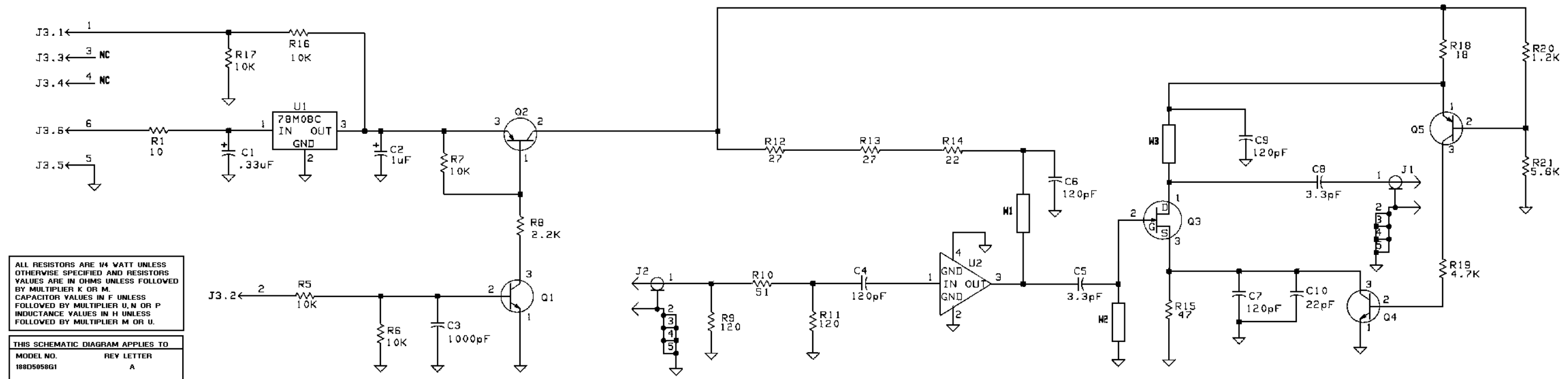

ALL RESISTORS ARE 1/4 WATT UNLESS OTHERWISE SPECIFIED AND RESISTORS VALUES ARE IN OHMS UNLESS FOLLOWED BY MULTIPLIER K OR M. CAPACITOR VALUES IN F UNLESS FOLLOWED BY MULTIPLIER U, N OR P INDUCTANCE VALUES IN H UNLESS FOLLOWED BY MULTIPLIER M OR U.

THIS SCHEMATIC DIAGRAM APPLIES TO	
MODEL NO.	REV LETTER
188D5058G1	A

(188D5056, Rev. 5)

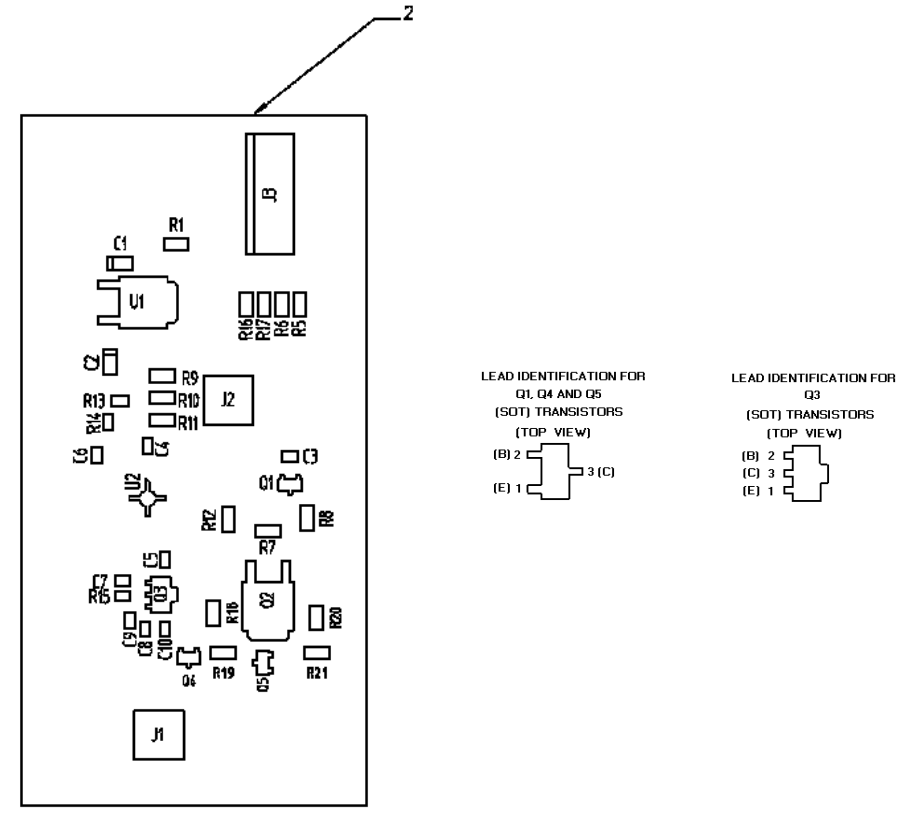

LEAD IDENTIFICATION FOR Q1, Q4 AND Q5 (SOT) TRANSISTORS (TOP VIEW)

LEAD IDENTIFICATION FOR Q3 (SOT) TRANSISTORS (TOP VIEW)

BUFFER AMPLIFIER
188D5056G1

(188D5058, Rev. 4)

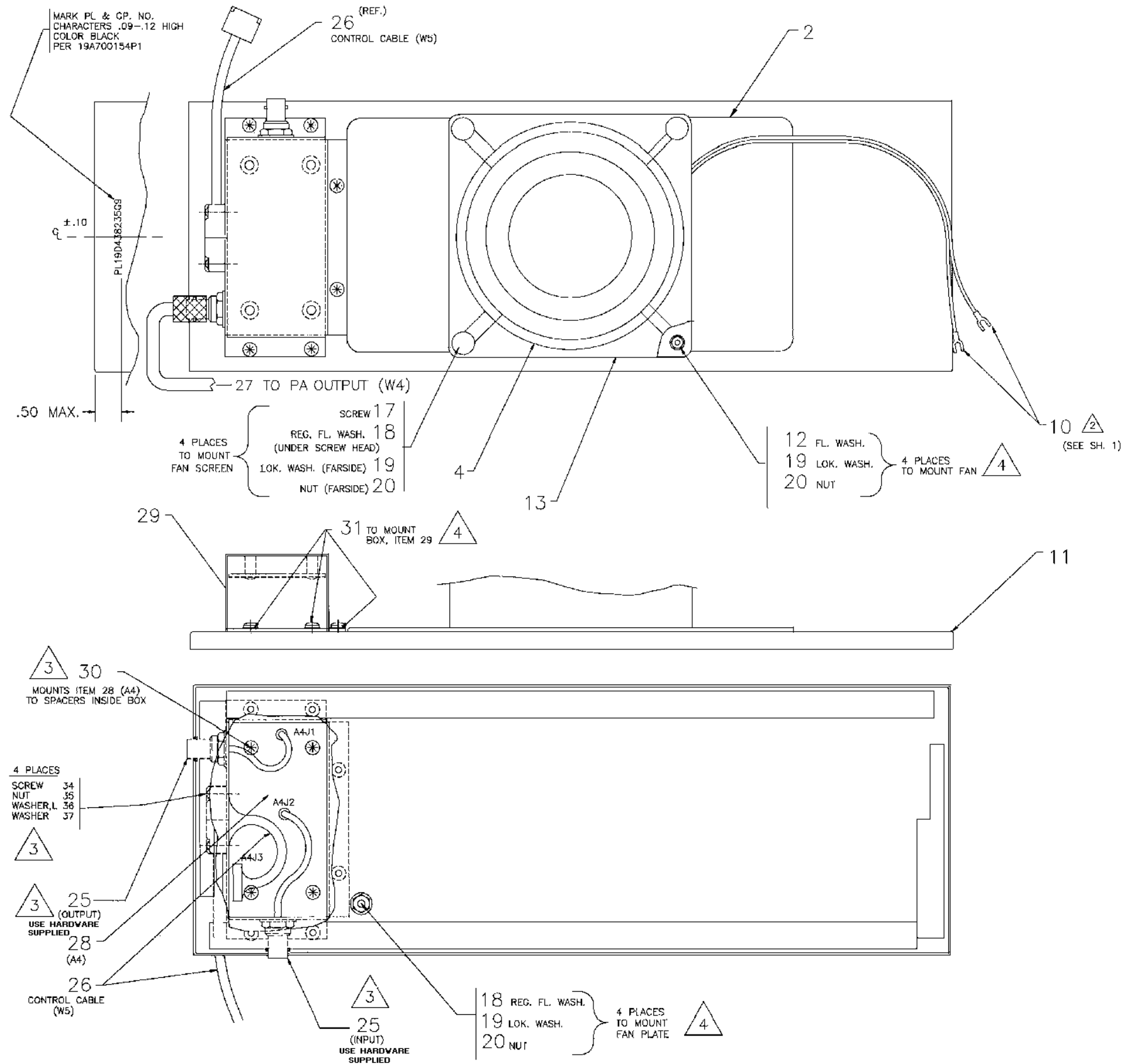

3 TORQUE HARDWARE TO 6 in lbs.

4 TORQUE HARDWARE TO 10 in lbs.

33 OTHERWISE SAME AS PART 1

POWER AMPLIFIER FAN ASSEMBLY
19D438235G9

(19D438235, Sh. 2, Rev. 1)