

MAINTENANCE MANUAL

**MDX
POWER AMPLIFIER BOARDS
19D904792G2 (403-440 MHz)
19D904792G1 (440-470 MHz)
19D904792G3 (470-512 MHz)**

TABLE OF CONTENTS

	<u>Page</u>
DESCRIPTION	1
CIRCUIT ANALYSIS	1
SERVICE NOTES	2
PARTS LIST	3
PRODUCTION CHANGES	3
OUTLINE DIAGRAM.....	4
SCHEMATIC DIAGRAM.....	5

DESCRIPTION

The Power Amplifier Board (A4) used in the MDX radio is housed in a cavity running parallel to the side of the radio main casting assembly. Refer to the combination manual for a complete mechanical layout of the radio.

The PA Board amplifies the driver output from the RF Board (approximately 13 watts) to a level of approximately 40 watts, over the frequency range of 403-512 MHz. There are no tuning adjustments on the board.

The board consist of a single stage RF power amplifier. Also included on the board are two multi-pin connectors used to distribute non-amplifier related signals in the radio. Two **SMB** connectors are used to apply drive to and take RF output from the amplifier. The 403-512 MHz range of frequencies is covered by three groups of PA Boards:

- 19D904792G2 (403-440 MHz)
- 19D904792G1 (440-470 MHz)
- 19D904792G3 (470-512 MHz)

CIRCUIT ANALYSIS

The driver output from the RF Board (13 watts, 50 ohms impedance) is matched to the base of transistor Q1 by capacitors C10, C11, C15 and a 50 ohm microstrip. Inductor L2 provides a bias return for class "C" operation. A network consisting of capacitor C19 and resistor R1 enhances stability.

Once the drive is amplified to approximately 45 watts by Q1, it is matched back up to 50 ohms by capacitors C7, C8, C12, C13/C17, C5/C18, C6 and the 50 ohm microstrip. Capacitor C4 is a DC blocking capacitor, which keeps DC voltage from appearing at the amplifier output.

Supply voltage (A+) is applied to the collector of power transistor Q1 through a network consisting of inductor L1 and capacitors C1, C2, C3, C14 and C16. In addition to enhancing stability, these components also prevent RF from getting onto the A+ line.

The amplifier output is fed back to the radio RF Board where it passes through the antenna switch, low pass filter and directional coupler before being applied to the antenna connector.

Supply voltage (A+) is applied through 6-pin connector J4 by feedthru capacitor assembly Z903. Other non-amplifier related signals are routed through the PA Board for distribution to other boards in the radio. These include A+, switched A+, relay and volume/squelch HI. A wiring harness plugs into connector J3 for this purpose.

SERVICE NOTES

This amplifier can be easily checked without removing it from the radio. RF input (at connector J1) and output (at connector J2) impedances are 50 ohms.

Remove all power from the radio when servicing the PA Board. The radio power switch does not remove A+ power from the board.

There are 12 chip mica capacitors on this PA Board. If any are removed, replace them with a new part since they are easily damaged. Apply them in the exact positions shown in the outline diagram. Failure to do this will have an adverse effect on amplifier gain, bandwidth and efficiency.

PA TRANSISTOR REPLACEMENT

1. Remove the two retaining screws securing PA transistor Q1 to the chassis assembly.
2. Unsolder the six leads of the transistor and remove it from the printed wire board. Be careful not to damage the board.
3. Remove all excess solder from the board near Q1 and clean the board to allow the new transistor to be positioned properly. Refer to the Figure and trim the new transistor leads (if required) to the same lead lengths of the transistor just removed.

4. Apply silicon grease to the back of the replacement transistor and place the transistor in the mounting cutout. Make sure that the base and collector leads are not reversed.
5. Replace the transistor mounting screws, leaving them loose at this time. Align the leads on the transistor being replaced with the microstrip. Position each lead so that a maximum amount of lead is in contact with the microstrip. Tighten each mounting screw to 4 ± 1 inch-pounds.
6. "Tin" the 6 transistor leads and then using 2% silver solder. Solder each lead to the printed wire board.
7. **Torque** the mounting screws to **6 inch-pounds**. Remove any flux left on the circuit board.

NOTE

The PA transistor contains Beryllium Oxide, a **TOXIC** substance. If the ceramic or other encapsulation is opened, crushed, broken or abraded, the escaping dust may be hazardous if inhaled. Use care when replacing the transistor.

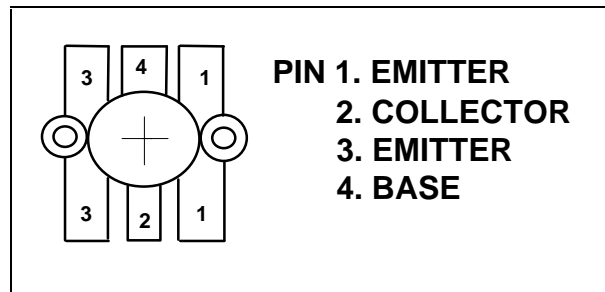

PA TRANSISTOR LEAD IDENTIFICATION

POWER AMPLIFIER BOARD
19D904792G2 (403-440 MHz)
19D904792G1 (440-470 MHz)
19D904792G3 (470-512 MHz)

Issue 4

SYMBOL	PART NUMBER	DESCRIPTION
----- CAPACITORS -----		
C1	19A702236P42	Ceramic: 47 pF ±5%, 50 VDCW, temp coef ±30 PPM.
C2	19A702052P33	Ceramic: 0.1 μF ±10%, 50 VDCW.
C3 and C4	19A705108P36	Mica Chip: 91 pF ±5%, 500 VDCW, temp coef 0 + 50 PPM.
C5	19A705108P201	Mica Chip: 1.0 pF ±0.25 pF, 500 VDCW, temp coef 0 + 200 PPM/°C. (G1, G2).
C5	19A705108P203	Mica : 1.5 pF ±0.25 pF, 500 VDCW, temp coef 0 + 200 PPM/°C. (G3).
C6	19A705108P11	Mica : 8.2 pF ±0.25 pF, 500 VDCW, temp coef 0 + 200 PPM/°C. (G1).
C6	19A705108P15	Mica: 12 pF ±5%, 500 VDCW. (G2).
C6	19A705108P9	Mica : 6.8 pF ±0.25pF, 500 VDCW, temp coef 0 + 200 PPM/°C. (G3).
C7 and C8	19A705108P23	Mica Chip: 27 pF ±5%, 500 VDCW, temp coef 0 + 100 PPM/°C. (G1).
C7 and C8	19A705108P24	Mica : 30 pF ±5%, 500 VDCW, temp coef 0 + 100 PPM/°C. (G2).
C7 and C8	19A705108P22	Mica : 24 pF ±5%, 500 VDCW, temp coef 0 + 100 PPM/°C. (G3).
C9	19A705108P35	Mica: 82 pF ±5%, 500 VDCW, temp coef 0 + 50 PPM/°C.
C10	19A705108P26	Mica : 36 pF ±5%, 500 VDCW, temp coef 0 + 100 PPM/°C. (G2).
C10	19A705108P23	Mica : 27 pF ±5%, 500 VDCW, temp coef 0 + 100 PPM/°C. (G1, G3).
C11	19A705108P11	Mica: 8.2 pF ±.25 pF, 500 VDCW, temp coef 0 + 200 PPM/°C. (G2).
C11	19A705108P9	Mica : 6.8 pF ±0.25pF, 500 VDCW, temp coef 0 + 200 PPM/°C. (G1).
C11	19A705108P13	Mica : 7.5 pF ±5%, 500 VDCW, temp coef 0 + 200 PPM/°C. (G3).
C12	19A705108P11	Mica : 8.2 pF ±0.25 pF, 500 VDCW, temp coef 0 + 200 PPM/°C. (G1).
C12	19A705108P7	Mica Chip: 5.6 pF ± 0.25 pF, 500 VDCW. (G3).
C12	19A705108P12	Mica : 9.1 pF ±5%, 500 VDCW, temp coef 0 + 200 PPM/°C. (G2).
C13	19A705108P12	Mica Chip: 9.1 ±5%, 500 VDCW, temp coef 0 + 200 PPM/°C. (G1).
C13	19A705108P10	Mica : 7.5 pF ±.25 pF, 500 VDCW, temp coef 0 + 200 PPM/°C. (G3).
C14	19A702052P28	Ceramic: 0.022 μF ±10%, 50 VDCW.

SYMBOL	PART NUMBER	DESCRIPTION
C15	19A705108P25	Mica Chip: 33 pF ±5%, 500 VDCW, temp coef 0 + 50 PPM/°C.(G1, G2).
C15	19A705108P25	Mica : 33 pF ±5%, 500 VDCW, temp coef 0 + 100 PPM/°C. (G1, G2).
C15	19A705108P24	Mica : 30 pF ±5%, 500 VDCW, temp coef 0 + 100 PPM/°C. (G3).
C16	19A701534P16	Tantalum: 6.8 μF, ±20%, 35 VDCW.
C17	19A705108P15	Mica : 12 pF ±5%, 500 VDCW, temp coef 0 + 100 PPM/°C. (G2).
C18	19A705108P208	Mica: 3 pF ±.25 pF, 500 VDCW, temp coef 0 + 200 PPM/°C. (G2).
----- JACKS -----		
J1 and J2	19A705512P1	Connector, RF, SMB series.
J3	19A700072P33	Printed wire: 7 contacts rated @ 2.5 amps; Sim to Molex 22-27-2071.
J4	19A705245P1	Printed wire: 6 contacts rated @ 2.5 amps; Sim to Molex 10-02-1062.
----- INDUCTORS -----		
L1	19B800891P2	Coil, RF Choke: sim to Paul Smith SK-890-1.
L2	19B800891P6	Coil, RF: .084 μH; sim to Paul Smith SK-890-1.
----- RESISTORS -----		
R1	19A700113P7	Composition: 4.7 ohms ±5%, 1/2 w. (Used in G1).
R1	19A700113P164	Composition: 1.2 ohms ±5%, 1/2 w. (Used in G2).
R1	19A700113P3	Composition: 3.3 ohms ±5%, 1/2 w. (Used in G3).
TX PA Kit 344A4256G4 (440-470 MHz)		
----- TRANSISTOR -----		
Q1	344A3948P1	Power Transistor, NPN, Silicon, 50 Watt, UHF
----- MISCELLANEOUS -----		
1	19A702364P208	Screw, Machine, Pan Head, Steel.
2	19A700033P3	Washer, lock, External tooth.

Production Changes

Changes in the equipment to improve or to simplify circuits are identified by a "Revision Letter", which is stamped after the model number of the unit. The revision stamped on the unit includes all previous revisions. Refer to the Parts List for descriptions of parts affected by these revisions.

Rev. A PA BOARD 19D904792G1-3

To improve radio performance at temperature extremes.
 C16 was 10μF (19A703314P10).
 C11 was 7.5pF (19A705108P10).

Rev. B PA BOARD 19D904792G3

To improve receiver sensitivity and reduce spurious response.
 R1 was 1.2 ohm (19A700113P164).

*COMPONENTS ADDED, DELETED OR CHANGED BY PRODUCTION CHANGES

COMPONENT SIDE

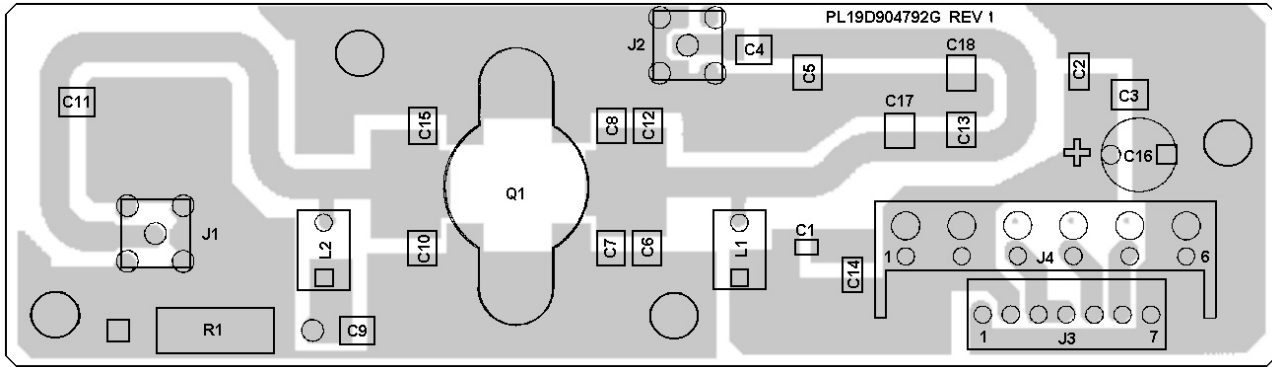

**Power Amplifier Board
19D904792G1, G2 & G3**

(19D904792, Rev. 2)
(19D904690, Component Side, Rev. 3)

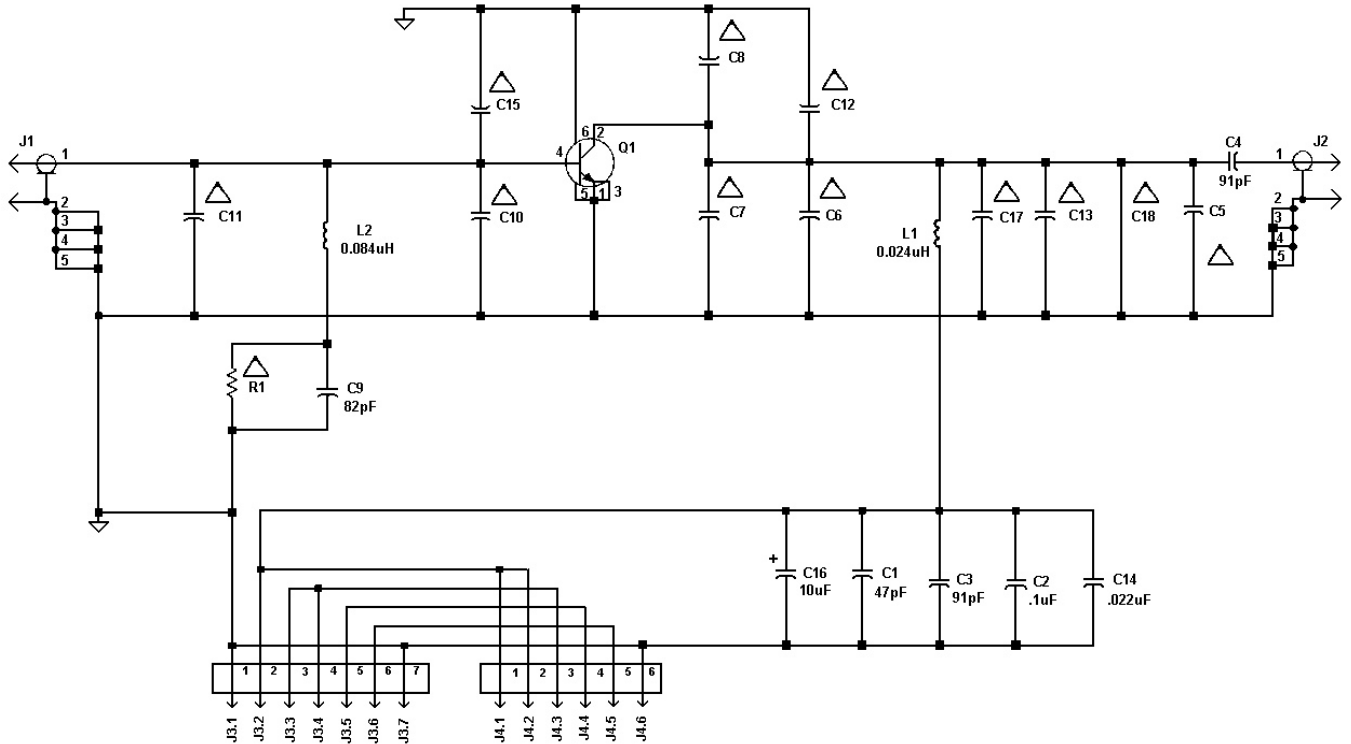

Ref. Des.	GROUP 7 440-470 MHz	GROUP 8 403-440 MHz	GROUP 9 470-512 MHz
C5	1.0 pF	1.0 pF	1.5 pF
C6	8.2 pF	12 pF	6.8 pF
C7	27 pF	30 pF	24 pF
C8	27 pF	30 pF	24 pF
C10	27 pF	36 pF	27 pF
C11	6.8 pF	8.2 pF	10 pF
C12	8.2 pF	12 pF	5.6 pF
C13	9.1 pF	—	7.5 pF
C15	33 pF	33 pF	30 pF
C17	—	12 pF	—
C18	—	3.0 pF	—
R1	4.7	1.2	3.3

For Groups 1 & 7 and 3 & 9 on PL19D904792 C13 and C5 will be used. For Groups 2 & 8 C17 and C18 will be used instead of C13 and C5.

**Power Amplifier
19D904792G1, G2 & G3**

(19D904791, Rev. 4)

THIS SCHEMATIC DIAGRAM APPLIES TO	
MODEL NO.	REV LETTER
19D904792G1	A
19D904792G2	A
19D904792G3	B

Ericsson Inc.
Private Radio Systems
Mountain View Road
Lynchburg, Virginia 24502
1-800-528-7711 (Outside USA, 804-528-7711)

Printed in U.S.A.