

Mobile Communications

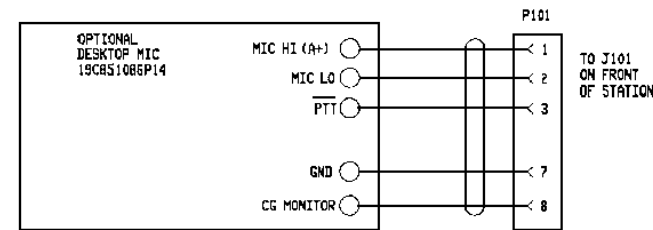

ORION Desk Top Station

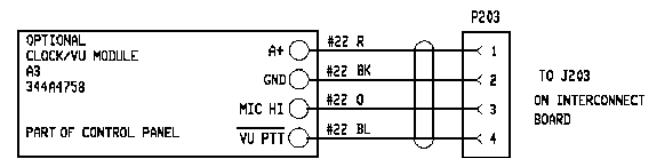
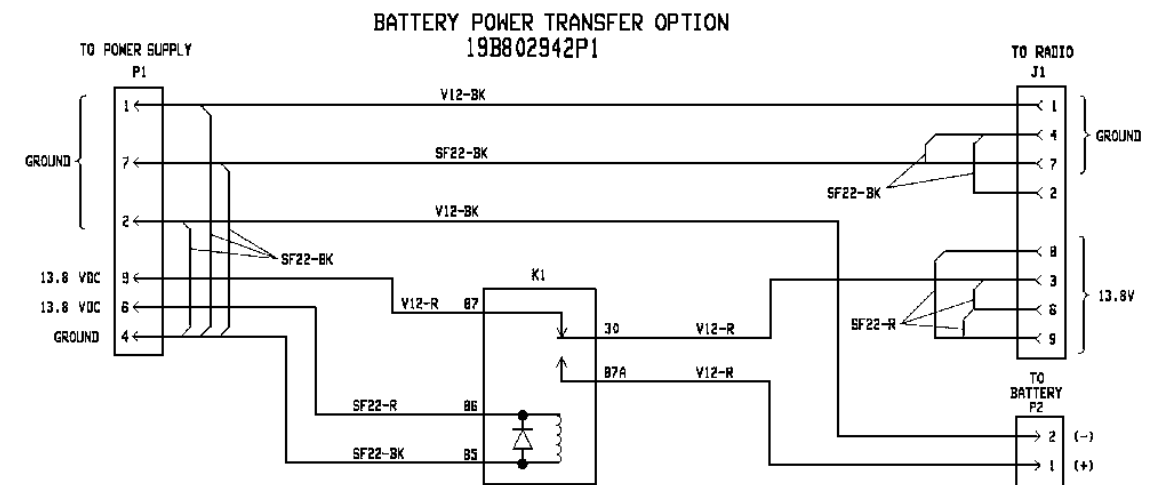

(188D5407, Sh. 3, Rev. 0)

TABLE OF CONTENTS

Interconnect Board LBI-39052
 Power Supply LBI-38751

TABLE OF CONTENTS

	<u>Page</u>
SYSTEM SPECIFICATIONS	1
DESCRIPTION	2
MECHANICAL PACKAGE	2
OPERATION	2
INTRODUCTION	2
OPERATION OF THE STANDARD STATION WITHOUT OPTIONS	2
ASSEMBLY DIAGRAM & PARTS LIST	3-4
INTERCONNECTION DIAGRAM	5

SYSTEM SPECIFICATIONS*

FREQUENCY RANGE	Refer to the applicable ORION Mobile Radio Maintenance Manual.
INPUT VOLTAGE	90-130 VAC @ 50/60 Hz 180-260 VAC @ 50/60 Hz (Standby Battery 13.8 VDC nominal)
AC INPUT POWER	500 watts @ 4 amperes (maximum)
Transmit	300 watts @ 2.4 amperes (maximum)
Receive	70 watts @ 1.8 amperes (maximum)
POWER OUTPUT RATINGS	Refer to the applicable ORION Mobile Radio Maintenance Manual. (The High Power ORIONS are not available in the Desk Top Station Application).
DUTY CYCLE (EIA)	Receiver 100%, Transmitter 20%
TEMPERATURE RANGE	-30°C to +60°C (-22°F to +140°F) (Performance specified per EIA)
SPEAKER	4 ohms
DIMENSIONS (HxWxD)	14x50x43 cm (5.5x20x17 inches)
WEIGHT	22.8 lbs less Mobile

* For detailed transmitter and receiver specifications, refer to the appropriate mobile maintenance manual.

PACKAGE NUMBERS

Package Number	Includes	Description
DSDX01	DSNN1F0 FC1E LA1T PS5Z CE9R CP5U AP5C	ORION Local Control Combination Number ORION Station Equipment EGE Label 30A, 120 VAC Power Supply ORION USA Power Cable Local Control Panel Application Assembly
DSDX08	DSNN1F0 FC1E LA1T PS5Z CE9R CP5W	ORION Local Control with Clock/VU Combination Number ORION Station Equipment EGE Label 30A, 120 VAC Power Supply ORION USA Power Cable Local Control Panel with Clock/VU
OPTIONS	DSSU3H DSZM1K	Standby Power Transfer Kit (Field Install) External Weatherproof Speaker and Cord Set (Delta Style)

APPLICABLE MAINTENANCE MANUALS

Installation Instruction	LBI-38977
Operator's Manual	LBI-38976
Interconnect Board	LBI-39052
Clock/VU Module	LBI-39032

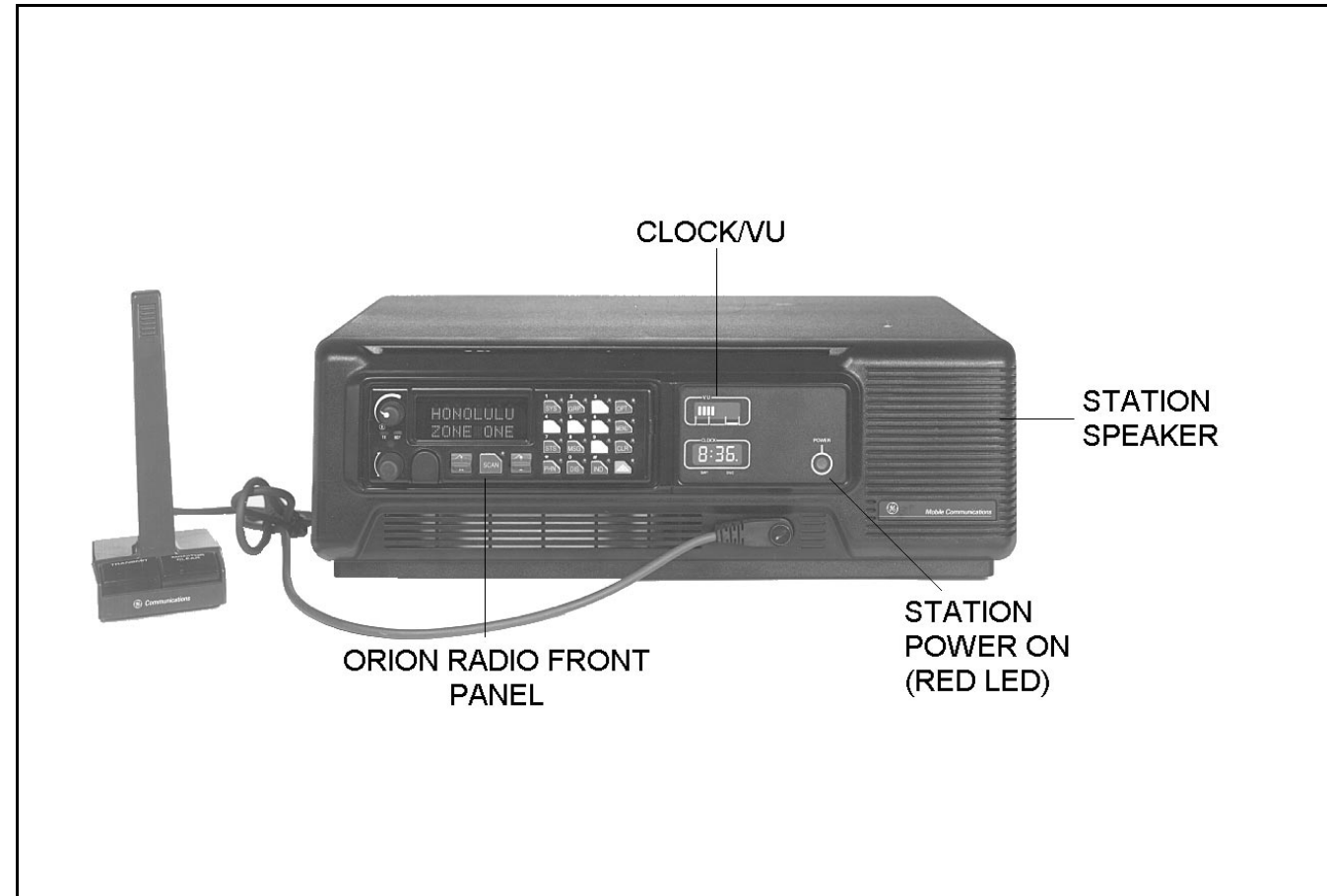

Figure 1 - Base Station Controls and Indicators

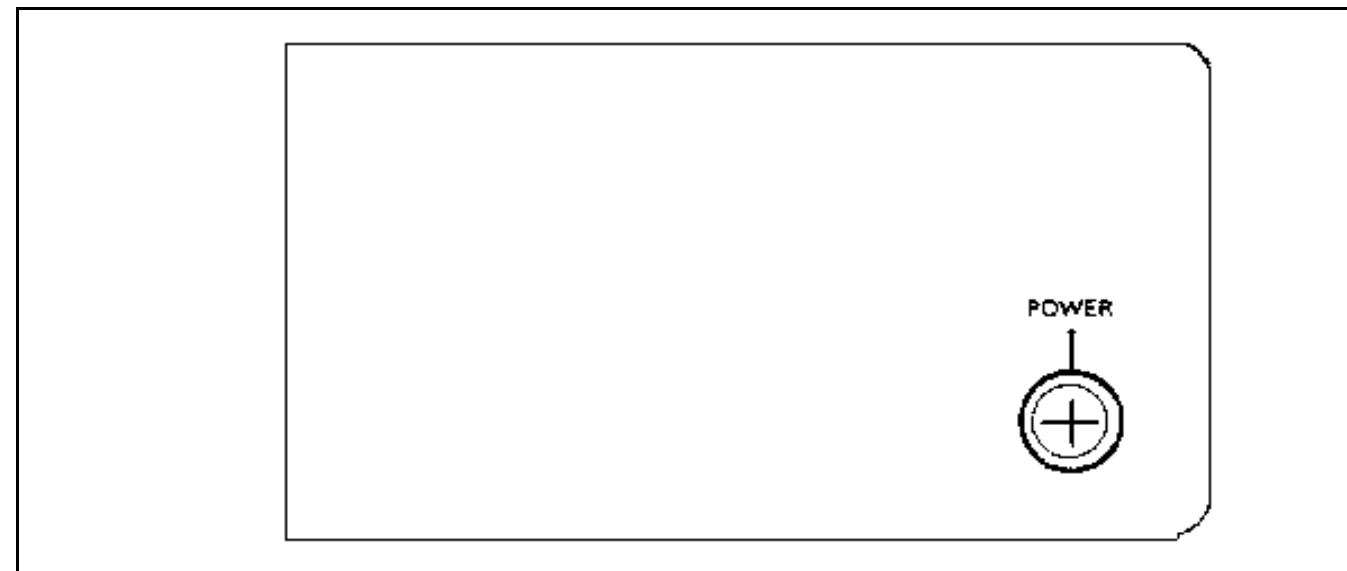

Figure 2 - Control Panel with Single LED Power Indicator

DESCRIPTION

The ORION Desk Top Station is an all solid state station for local/remote control operation. The most advanced manufacturing techniques are used to provide the highest quality and reliability.

The station is available in all frequency bands and up to mid power levels available in the ORION Mobile radio family.

MECHANICAL PACKAGE

The station is housed in an attractively styled Desk Top cabinet and operates over a wide range of AC power sources. The basic station consists of a Control Panel, a 30-ampere power supply, and an ORION mobile radio unit. The Desk Top Station operates from 120 or 240 VAC sources at 50/60 Hz. Input power variations of $\pm 20\%$ are tolerated (see Figures 1 and 2). The basic Desk Top Station package combination is equipped with:

- AC Power Supply (120/240 VAC, 50/60 Hz)
- Interconnect Board
- Speaker, 3.5 inches for improved radio audio quality
- Slow speed, low noise, 12 VDC fan

The transmitter power output of the Desk Top Station is the same as the selected mobile radio. The station meets all applicable radio EIA standards.

Interconnect Board

The Interconnect Board interconnects the radio in the Desk Top Station with the controls and options. See LBI-39052 for full details. When the radio and options are connected, the following functions are controllable:

- Receiver Muting (RX Mute)
- Audio Switching
- Local Keying
- Channel Guard Monitor
- Volume Adjustment
- Frequency Selection
- Voltage Regulator and Power Supply choice

The Interconnect Board is provided with jacks for connection to:

- Radio
- Control Panel
- Power Supply

- Station Speaker
- Station Fan
- Desk Top Microphone
- Clock/VU Module (Option)

A single transistor (Q201) is used to reduce the 13.8 VDC power supply voltage to a suitable voltage to power the station fan. Except for this transistor, the only other circuitry on the Interconnect Board consists of jack interconnections.

OPERATION

INTRODUCTION

The front panel of the Desk Top Station, as shown in Figure 1, includes the front of an ORION mobile radio, as well as a Control Panel. The station is assembled as a standard station with or without one of the combinations of options. The Control Panel is illustrated for each combination.

1. **Standard Desk Top Station, without Options** - The standard station has only a single red LED to indicate when the power supply is ON (see Figure 2).

The power supply ON/OFF switch is mounted on the rear of the station housing.

OPERATION OF THE STANDARD STATION WITHOUT OPTIONS

Operation of the standard station without any option begins with turning ON the POWER switch. The POWER switch is located on the rear of the power supply, accessible at the rear of the Desk Top Station housing. The POWER indicator lights, showing that the power supply is ON. The radio is NOT on yet. The Power Supply provides power to the station cooling fan. The fan is thermally controlled and is on only when there is sufficient heat inside the station cabinet. The radio has its own ON/OFF POWER switch.

The radio uses the Station Speaker mounted behind the front cap of the station. The radio has no internal speaker.

Further operation of the station is that of the ORION Mobile radio. Refer to the applicable Operator's Manual for more detailed information.

CLOCK/VU Option

See LBI-39032 for full details.

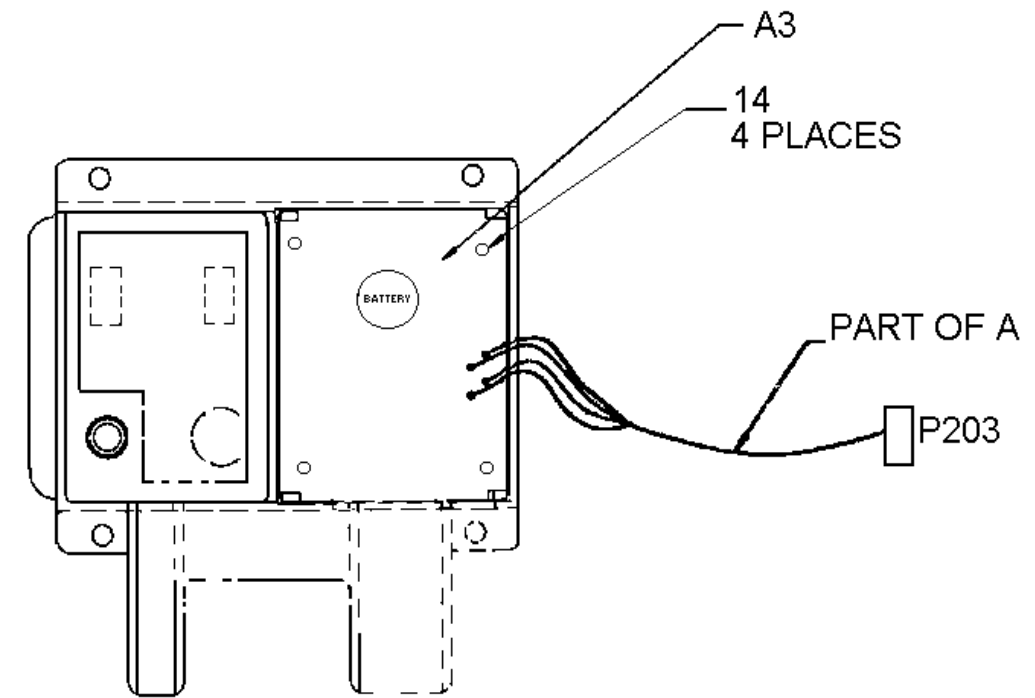
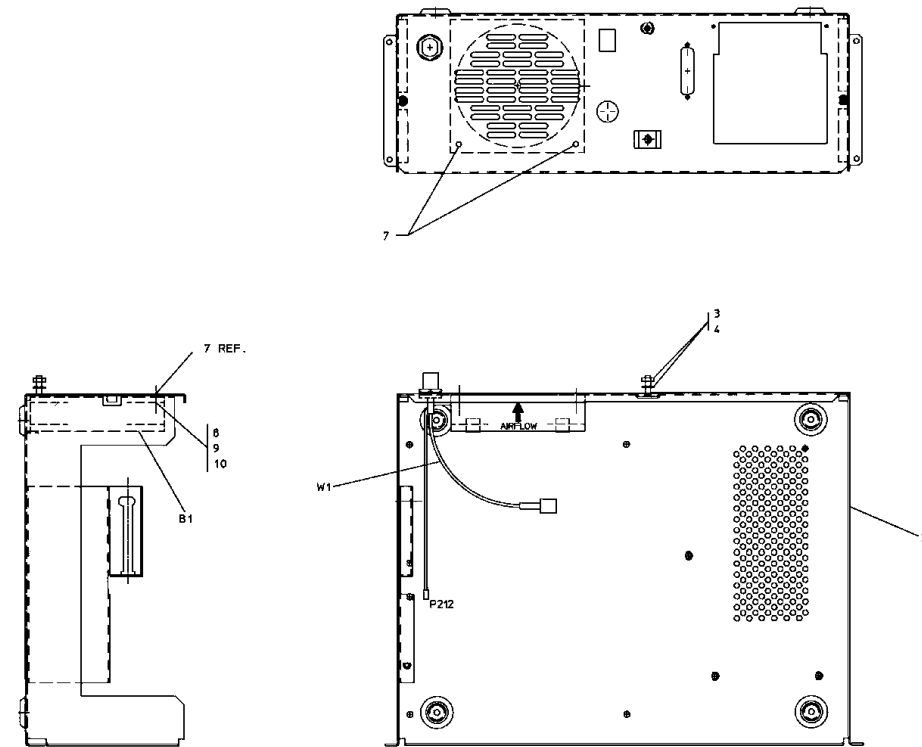

**19D904706G1
CHASSIS ASSEMBLY**

SYMBOL	PART NO.	DESCRIPTION
		----- MODULE -----
B1	5493477P9	Fan, Axial.
		----- CABLES -----
W1	19B801454P42	Cable. RF Antenna.
W2	19B802554P19	Cable. Radio/Option. (USA Version).
W2	19B802554P18	Cable. Radio/Option. (European Version).
W3	19B852054P3	Cable. DC Power. (USA Version).
W4	19B801729P2	Cable. Microphone.
W5	344A3337P3	Cable. LED/Speaker.
		----- MISCELLANEOUS -----
2	19D904703P1	Chassis.
3	N210P16B6	Nut, steel: No. 10-32.
4	N403P19B6	Lockwasher: No. 10.
7	19A702364P413	Machine screw, TORZ Drive, M3.5-0.6 x 13.
8	19A701312P5	Flatwasher: M3.5.
9	19A700033P6	Lockwasher, external tooth, M3.5.
10	19A700034P5	Hex nut: No. M3.5 x 0.6.

**CONTROL PANEL
19D904861G1 & G5**

SYMBOL	PART NO.	DESCRIPTION
A3	344A4758P1	Clock/VU (Used in G5).
		----- INDICATING DEVICES -----
DS1	19A134354P1	Optoelectronic: Red; sim to HP 5082-4655.
		----- MISCELLANEOUS -----
3	19D904702P1	Control Panel.
7	19C852432P1	Panel Marking. (Used in G1.)
4	19A116677P1	Bushing: sim to Hewlett-Packard No. 5082-4707.
11	19C852432P5	Panel Marking. (Used in G5).
14	344A4432P406	Screw, Threadflow.

**CHASSIS ASSEMBLY
19D904706G1**

(19D904706, Rev. 3)

**CONTROL PANEL
19D904861G1 & G5**

(19D904861, Sh. 2, Rev. 1)

19D904705G2

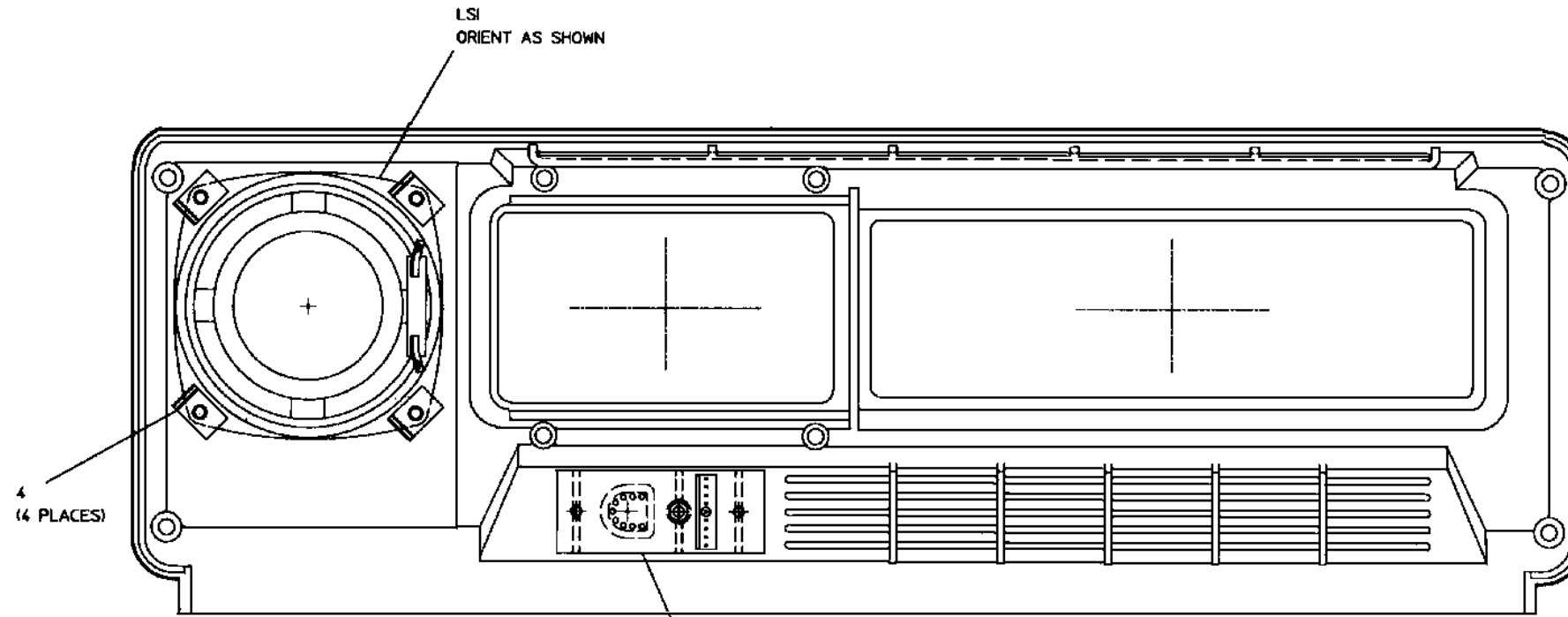

SYMBOL	PART NO.	DESCRIPTION
----- ASSEMBLIES -----		
A1	19C852376G1	Component Board.
----- JACKS -----		
J101	344A4485P1	Connector, special; sim to CONXAL E4408.
J102	19A704852P35	Connector.
--- MISCELLANEOUS -----		
4	19A702455P1	Nut. Self-CNC.
----- LOUDSPEAKERS -----		
LS1	344A3269P1	Permanent Magnet Loudspeaker.
----- MISCELLANEOUS -----		
2	19D904700P2	Front Cap.
3	19A702362P310	Machine screw, TORX Drive M3-0.5 x 10.
4	19C307038P16	Nut. Push-On.

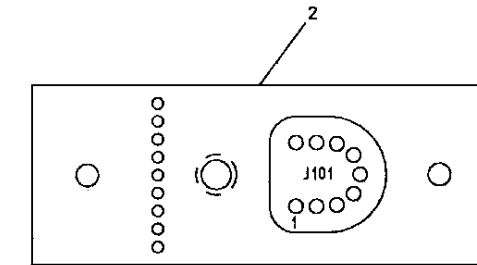
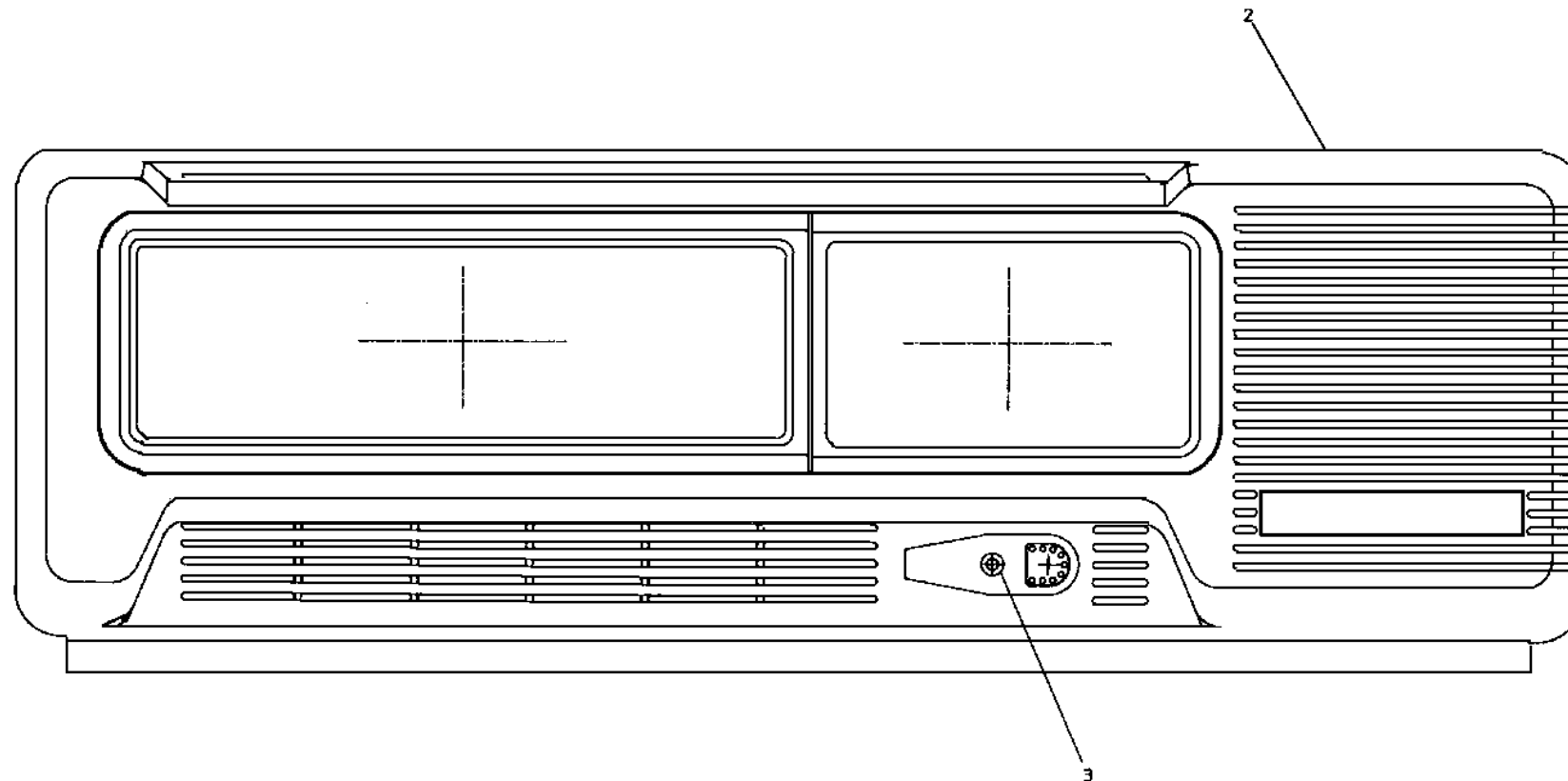

TOP SIDE

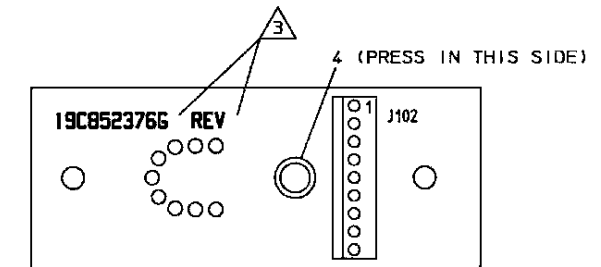

BOTTOM SIDE

FRONT CAP ASSEMBLY
19D904705G1

(19D904705, Rev. 1)

