

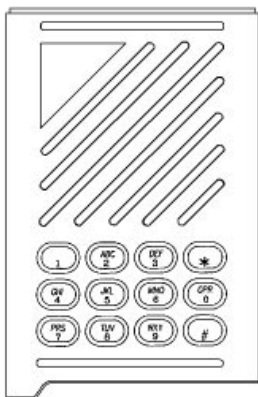

Mobile Communications



**DTMF ENCODER
344A4209P23
(MHDE5U)**

Installation Manual

TABLE OF CONTENTS

INTRODUCTION	3
General Description	3
Programming	3
THEORY OF OPERATION	3
INSTALLATION & ALIGNMENT	4
PARTS LIST	8
SCHEMATIC DIAGRAM	10

This manual is published by **Ericsson GE Mobile Communications Inc.**, without any warranty. Improvements and changes to this manual necessitated by typographical errors, inaccuracies of current information, or improvements to programs and/or equipment, may be made by **Ericsson GE Mobile Communications Inc.**, at any time and without notice. No part of this manual may be reproduced or transmitted in any form or by any means, electronic or mechanical, including photocopying and recording, for any purpose, without the express written permission of **Ericsson GE Mobile Communications Inc.**

INTRODUCTION

GENERAL DESCRIPTION

The Dual-Tone Multi-frequency (DTMF) encoder allows DTMF operation in the *Monogram Series* Portables.

When installed, the DTMF encoder will provide the radio with ability to use all of the combinations found on the DTMF keypad.

PROGRAMMING

Programming of the DTMF encoder is not necessary or required.

THEORY OF OPERATION

All tone frequency generation is provided by U2. U2 is a standard generic 5098 DTMF encoder device commonly used in telephone circuitry. Internally the device contains a crystal oscillator which operated on 3.579 MHz (commonly known as the clock), two programmable down-counters which divide the clock output frequencies to provide DTMF tones which are added together when a keypad button is depressed. The resulting sine wave output is enabled by either the XMIT ENABLE or it's inverse.

The speaker output provides an amplitude which may be heard on the speaker.

The DTMF OUTPUT is adjustable with R8 and routed to the audio input within the radio.

A regulated 5.0 VDC source for U2 is provided by U1. Beyond the regulator, decoupling capacitors are provided to keep RF out of the circuit.

INSTALLATION AND ALIGNMENT

NOTE

The installation and alignment instructions assume the radio has been properly programmed, aligned and deviation correctly set prior to the incorporation of the DTMF option.

1. Remove the battery.
2. Remove the two front cover retaining screws from the bottom of the unit as shown in Figure 1.
3. Remove the front cover and disconnect the 4-pin plug from CON 406.

NOTE

Retain the front cover and screws for future use or as a source of replacement parts.

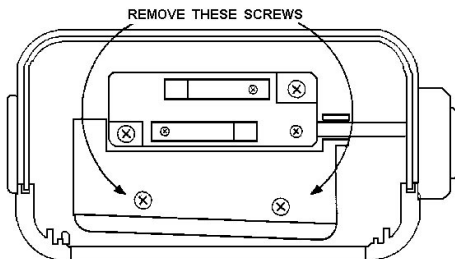

Figure 1 - Bottom of Radio

4. Remove solder jumper from LK7.
5. Add solder jumper to LK6.
6. Remove the solder jumper from LK3 and install the supplied 10K ohm resistor (R29/060-103-8Z) in its place.
7. Add the supplied 470 pF chip capacitor (R29/134-711-9) to the trace at the lower portion of LK3 as shown.

NOTE

Installation of the 470 pF chip capacitor requires the removal of the soldermask from the printed wiring board. USE CAUTION WHILE REMOVING TO AVOID DAMAGING THE PRINTED WIRING BOARD TRACES.

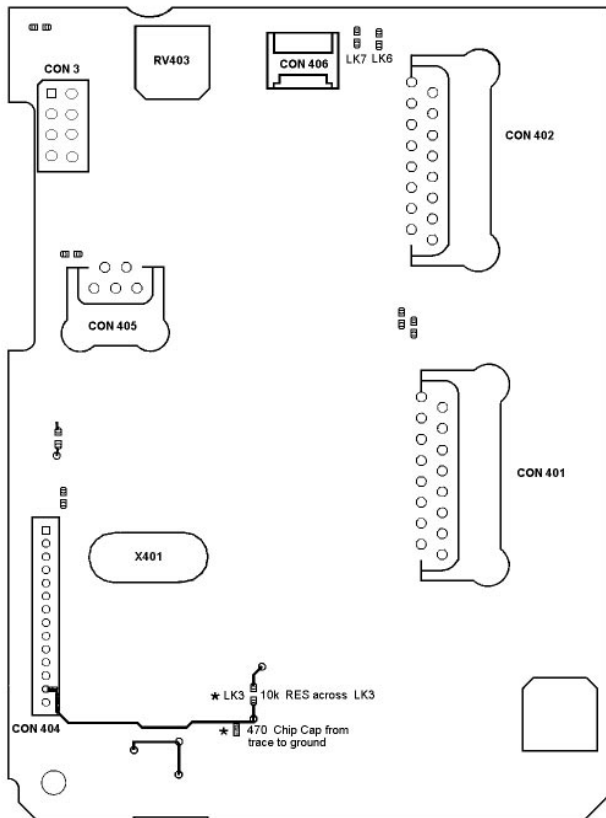

Figure 2 - Radio Printed Wiring Board Layout

8. Connect the DTMF encoder 14-pin interface connector to CON 404.
9. Connect the 4-pin speaker and microphone connector to CON 406.
10. Apply B+ (10.8 VDC) to battery terminals using a battery or power supply.
11. Connect the RF output to a service monitor or modulation analyzer using appropriate attenuators as required.
12. Set the High/Low Power selector to High.
13. Place the unit in transmit while depressing the "5" key and adjust R8 for 3 kHz \pm 100 Hz deviation.
14. Depress the "1" and "#" keys and verify that the deviation is 3 kHz \pm 500 Hz.
15. Place the front cover into the proper position. Use care to avoid damaging wires when affixing the front cover.
16. Secure the cover by using the two screws (R29/600-757) supplied in the MHDE5U kit in the bottom of the unit as shown in Figure 1. **DO NOT OVERTIGHTEN.**

NOTE

If your *Monogram Series* portable is programmed over a wide range of frequencies, select a frequency in or near the center of the frequency range for making the deviation adjustment. Accordingly, if the DTMF encoder will be used only on one channel, the alignment should be performed on that channel for best performance.

PARTS LIST

DTMF ENCODER 344A4209P23 (MHDE5U) ISSUE 1

SYMBOL	PART NO.	DESCRIPTION
		DTMF BOARD
C1	R29/141-014-1	Capacitor, tantalum: 1 μ F
C2	R29/130-172-2	Capacitor: 0.01 μ F
C3	R29/134-726-3	Capacitor: 470 pF
C4	R29/141-014-1	Capacitor, tantalum: 1 μ F
C5	R29/130-172-2	Capacitor: 0.01 μ F
C6	R29/134-726-3	Capacitor: 470 pF
C7 thru C9	R29/134-772-1	Capacitor: 47 pF
C10	R29/132-220-2	Capacitor: 220 pF
C11	R29/130-172-2	Capacitor: 0.01 μ F
C12	R29/141-014-1	Capacitor, tantalum: 1 μ F
C13	A29/142-201-8	Capacitor, tantalum: 2.2 μ F
CR1 thru CR4	R29/999-073-2	Diode, LED: Red, SLM-13VW
R1 and R2	R29/060-470-9	Resistor: 47 ohm
R3	R29/060-513-5	Resistor: 51K ohms
R4 and R5	R29-060-103-8Z	Resistor: 10K ohms
R6	R29/060-104-9Z	Resistor: 100K ohms
R7	R29/060-100-5	Resistor: 10 ohm
R8	R29/073-501-2	Resistor, semi-fixed: 500 ohm
R9	R29/060-474-3	Resistor: 470K ohms
Q1 thru Q3	R29/218-018-2	Transistor: sim to MMBT 3904
X1	R29/260-148-1	Crystal: 3.579645 MHz
U1	R29/223-119-8	IC: sim to LM 78L05
U2	R29/999-068-1	IC: sim to TCM5089

SYMBOL	PART NO.	DESCRIPTION
		MISCELLENOUS
	R29/718-849	Cover, N190J 2032
	R29/999-084-0	Molex Connector
	R29/999-114-0	Interconnect PCB
	R29/628-060	Screw, PH 1.7x4-2S (Quantity 4)
	R29/420-112-4	Speaker
	R29/420-206-0	Microphone, WM-063AT
	R29/504-916	4-Pin wiring assembly
	R29/723-776	Bracket, speaker
	R29/850-924	Bushing, microphone
	R29/894-600	Gasket
	R29/906-369	Felt, speaker
	R29/621-460	Screw, speaker bracket 2.6x5-2S (Quantity 2)
	R29/894-884-A	Keypad, silicon rubber
		THE FOLLOWING PARTS ARE PROVIDED IN KIT FOR INSTALLATION OF MHDE5U.
	R29/060-103-8Z	Resistor: 10K ohms
	R29/134-711-9	Capacitor: 470 pF
	R29/600-757	Screw: FH 2-56x7 (Quantity 2)

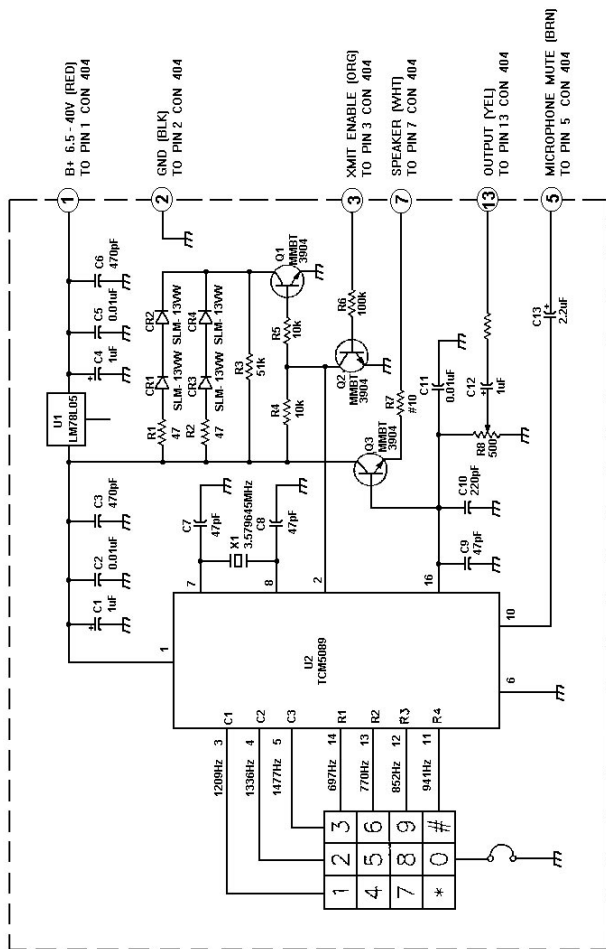



Ericsson GE Mobile Communications Inc.
Mountain View Road • Lynchburg Virginia 24502

Printed in U.S.A.