

Standard for Site Grounding and Protection

Table of Contents

Page

1. OBJECTIVE	3
1.1. GROUND THEORY	3
1.2. SCOPE	3
1.3. GENERAL	4
1.4. RESPONSIBILITY	4
1.4.1. Minimum Requirements	4
1.5. PROCESS & DEFINITION	4
1.5.1. Coax and Transmission Line Grounding	4
1.5.2. Equipment Grounding	5
1.6. GROUND WIRE COMPOSITION	5
1.6.1. Ground Rods	5
1.7. CONDUCTORS	5
1.8. CONNECTIONS	5
1.8.1. Below Ground	6
1.8.2. Above Ground	6
1.9. SURGE SUPPRESSION DEVICES	7
1.9.1. The Following Practices Are to be Avoided!	7
2. EXTERNAL GROUNDING SYSTEM	7
2.1. ANTENNA TOWER GROUNDS	7
2.1.1. Wooden Antenna Poles	7
2.1.2. Self Supporting Lattice Towers	7
2.1.3. Guyed Lattice Towers	7
2.1.4. Antenna Support Structures On Buildings	8
2.2. EQUIPMENT BUILDINGS	8
2.3. BULKHEAD PANEL	8
2.4. FENCES	8
2.4.1. Nearby Metal Objects;	9
2.5. TRANSMISSION LINES	9
2.5.1. Shield Grounds	9
2.6. COAXIAL SUPPRESSOR	9
2.7. TOWERTOP PREAMPLIFIERS	9
2.8. TOWER-MOUNTED MICROWAVE AND REPEATER EQUIPMENT	10
2.9. COMMUNICATIONS EQUIPMENT ROOM INTERNAL GROUNDING	10
2.9.1. Grounding Of Equipment Cabinets, Racks, And Shelves	10
2.9.2. CABLE TRAYS	10
3. PLANS AND DOCUMENTATION	11

NOTICE!

This manual covers Ericsson and General Electric products manufactured and sold by Ericsson Inc.

NOTE

Repairs to this equipment should be made only by an authorized service technician or facility designated by the supplier. Any repairs, alterations or substitution of recommended parts made by the user to this equipment not approved by the manufacturer could void the user's authority to operate the equipment in addition to the manufacturer's warranty.

NOTICE!

The software contained in this device is copyrighted by Ericsson Inc. Unpublished rights are reserved under the copyright laws of the United States.

This manual is published by Ericsson Inc., without any warranty. Improvements and changes to this manual necessitated by typographical errors, inaccuracies of current information, or improvements to programs and/or equipment, may be made by Ericsson Inc., at any time and without notice. Such changes will be incorporated into new editions of this manual. No part of this manual may be reproduced or transmitted in any form or by any means, electronic or mechanical, including photocopying and recording, for any purpose, without the express written permission of Ericsson Inc.

Copyright © June 1994, Ericsson, Inc.

1. OBJECTIVE

The fundamental objective of this document is to provide a standard for Ericsson site equipment grounding, with recommended methods that are essential to protect personnel, minimize component failure, and optimize performance by reducing electrical noise. Transient voltage introduced into a system often exceeds the operating parameters of electronic components and has destructive results. The fragile nature of semiconductors makes them even more susceptible to these externally induced transient voltages.

An effective ground system should include considerations that fulfill its purpose. These purposes are:

- Protect personnel by reducing the hazards of electrical shock.
- Provide a non-destructive low inductance path to ground for lightning strikes and currents.
- Provide a low inductance path to ground from cable shields and other metal encased RF handling devices (antennae etc...).
- Protect wiring and other electrical components from damage.
- Reduce noise and suppress damaging power spikes.

1.1. GROUND THEORY

All communications facilities are related to ground or earth either by capacitive coupling, accidental contact or designed contact. If a conducting path for a lightning stroke is provided between the point of contact of a strike to an edifice and a suitable ground apparatus or electrode, damage and shock hazards can be diminished.

In theory, a ground rod 1 inch in diameter driven into homogeneous 1000 ohm per meter (ohm/meter) soil for one meter would present only 765 ohms. Driving it another meter into the soil (two meters) would yield 437 ohms. Extending the depth to three meters would yield about 309 ohms.

By using three ground rods that are each one meter long, and driven into the same soil area one meter deep and one meter apart we could achieve a ground resistance of 230 ohms.

We quickly realize that we can get faster ohms reduction in ground resistance by installing multiple ground rods. If we also bury the interconnecting wire below the soil surface we are able to lower the ground resistance below 200 ohms.

With these conditions as a point of reference, the ERICSSON site installation should exhibit better than (below) five (5) ohms resistance between any connected point on the ground bus and earth ground. The exception to this

requirement is noted at section 2.1.4, ANTENNA STRUCTURES ON TALL BUILDINGS.

When making these measurements, an instrument similar to the AEMC Model 3700 HD will be used to make these measurements. The measurements will be made using the instructions provided with the **AEMC model 3710HD (ERICSSON CAT # LYAEMC_3710) or AEMC 3730 (ERICSSON CAT # LYAEMC_3730) Ground Test Instrument.**

Where ground measurements are to be made prior to site construction or where no present ground connections exist, it is recommended that a three or four point ground measurement be made and recorded. The use of an **AEMC model 4500 (ERICSSON CAT # LYAEMC_4500)** (or equivalent) digital ground test meter may be employed. If the equipment is not readily available, there are many electrical contractors and some power utilities who provide this service for a fee.

1.2. SCOPE

This standard has been prepared for both safety and damage prevention measures. The grounding, bonding, and shielding procedures are implemented to prevent damage to equipment, reduce Radio Frequency spectrum pollution and as a safety measure for maintenance and operating personnel.

The prime source of danger and damage is from lightning currents which are often conducted to the equipment by way of the coax transmission lines.

This document is to be used as a guide for the design and installation for protective bonding and grounding of all Ericsson radio and dispatch installations.

The isokeraunic (isobar levels) map shown in *figure seven (7)* attached to this document shows the mean annual number of days with thunderstorms in the United States. NOTE: The region with the highest frequency is centered around south and central Florida.

One of the better means to reduce the chance of damage from this source is to provide a low impedance path to ground for these currents without having the currents flow through the equipment.

Another means to control surge ingress via the electrical utility service is by installing a PolyPhaser Model PM240-BP (see *figure 9*), Joslyn Model 1265-85 or ERICSSON approved equivalent AC MOV and avalanche surge arrester on the incoming power lines. Additional surge protection (PM240-BP/figure 9) downstream of the breaker panel may be added for extra protection. Ericsson transmitting equipment is equipped with internal avalanche and MOV protection.

1.3. GENERAL

The following needs constitute a justification for grounding:

- 1) The need to control fast-rising electrical surges, which produce high voltage differences between the ends of single conductors such as heavy copper wires and bars.
- 2) The need to equalize surge potentials by controlled bonding of *Ericsson* Communications site ground elements.

These elements include the following:

- a) Non Isolated Ground Zones (IGZ) equipment grounds.
 - b) Surge Producers
 - c) Surge Absorbers (provides path to ground)
 - d) IGZ Grounds
- 3) The need to reduce voltage differences and control surge currents by using single-point grounding, which includes the following elements:
 - a) A common or master ground bar configuration for establishing a common voltage reference plane (with respect to earth "true" ground) for the entire *Ericsson* communications site and for dispersing lightning and power surge activity rapidly to earth via the halo and ring ground system.
 - b) A ground window bar (see appendix "A", figure A3), or equivalent (Half-hard copper cable entry bulkhead by PolyPhaser®), to establish a local point of reference potential for grounding sensitive electronic equipment. This is terminated on the master ground window as the single point ground and voltage reference for all equipment at the *Ericsson* communications installation.
 - c) A single ground point in the Isolated Ground Zone is at the master ground window. This again insures that potential equalization is true to any attached ground windows, and equipment.
 - d) The single point master ground bar will be cleaned to remove any oxidation to insure a low resistance connection. To establish sufficient metal to metal contact, an anti corrosion or antioxidant material (paste) is added at connecting points where grounding conductors are terminated. A complete description of the single point master ground is shown in detail in *appendix A*, figure A3 of this document.

1.4. RESPONSIBILITY

Throughout this document there will be references to ground rods and ground connections. In all cases mentioned there will be only one ground system at each site, building, room, or communications shelter. **ALL GROUNDS ARE TIED TOGETHER (see figure 1).**

There should be no separately maintained ground rods or ground systems that are associated with the communications shelter, site, building, or equipment room. Adherence to these requirements becomes the performance standard with respect to Ericsson Private Radio Systems communications facilities.

1.4.1. Minimum Requirements

The purpose of this specification is to establish minimum requirements for a grounding system which will provide a measure of personnel and equipment protection. In the event that any item specified within this document conflicts with the National Electrical code or local buildinggrounding related codes, those Codes may take precedence.

Protective measures to prevent equipment damage and personnel hazards against lightning will incorporate system grounding and bonding using good RF practices. While all conductors and connections have some associated resistance, the inductive reactance is normally much larger. All grounding and bonding conductors have low inductance interconnections to minimize the inductive voltage transients.

1.5. PROCESS & DEFINITION

As stated in the general overview of this document, all elements of the ground system, and conducting elements in near proximity to the system are connected and bonded together. This performs the function of maintaining any and all parts of the radio site at the same ground integrity, as related to true earth ground (see figure 1).

1.5.1. Coax and Transmission Line Grounding

At Ericsson repeater sites and antenna tower locations, our installers must attach a minimum of three lightning protection grounding kits to each coaxial line used at the site. Where vertical cable runs on towers exceed 200 feet, a grounding kit should be installed at 100 foot intervals. This process is illustrated in more detail in figure one, specifically points 1, 2, & 3. Grounding kits are shown in figure 13 and photos B11 & B12 of this document.

Each coax run will have an ANDREW *ARRESTOR Plus* lightning surge protector (see appendix "B" *figure B6*) or PolyPhaser® gas tube type (or equivalent), lightning arrester installed onto the coax near the cable entrance to the communications shelter or room. The Andrew *ARRESTOR Plus* are the preferred types and are believed to be the best light-

ning arrestors presently available. The ARRESTOR Plus is a *multi-strike* protection device that also optimizes IM performance.

These grounding kits will be terminated onto the master ground bar. All connections to the master ground bar window will be clean and free of any oxidation to insure a low resistance connection. Each of these arrestors are effective in limiting the amount of lightning energy that can be transferred to the equipment via the inner conductor of the coax or transmission line.

1.5.2. Equipment Grounding

Each equipment rack, equipment cabinet, or equipment shelf will be grounded to a site ground via the inner building ground window. In the case of communications shelters, the equipment enclosures will be attached to the main ground window in the same manner to this system "halo" ground.

1.6. GROUND WIRE COMPOSITION

No grounds will be run inside metal conduits because metal conduits increase the surge impedance and inductance of the grounding cables. The grounds which make up the interior "halo" ground will be of number 2 AWG or larger copper wire covered with a *nonconductive approved plastic covering. This covering is light green.* Where the halo ground is attached to exit ground wires, these wire(s) will be solid, tinned, *bare* copper, number 2 AWG or larger.

A complete grounding system for the antenna, towers, and buildings are provided. These include internal and external grounding systems for equipment in the communications buildings, grounding of the antenna towers and guys, transmission line, telephone line and AC power line grounding, and grounding of the Communications facility.

1.6.1. Ground Rods

Where an Ericsson ground system is installed, ground rods will be bare copper or copperclad steel, 5/8 inch in diameter, and a minimum of 8 feet in length. As discussed in "**General**" (1.3) at the beginning of this document, multiple interconnected ground rods are normally provided (see figure 1).

To maintain the integrity of the ground system, where space permits, a minimum distance between ground rods will be 10 feet. Exothermic bond/weld connections will be made at all ground rod connections.

1.7. CONDUCTORS

Conductors that are employed below ground for the purpose of connecting ground rods will use:

- a) Stranded bare copper wire, number 2 AWG or larger.
- b) Solid bare copper strap, with minimum of 18 AWG and minimum width of four inches.

Conductors used above ground for interconnecting ground rings, halo's, equipment (racks and cabinets), and other metal items will be:

- a) Solid or stranded copper wire number 6 AWG or larger
- b) Solid copper strap, with minimum thickness of 16 AWG and a minimum width of two inches.

Precautions against the use of connections where dissimilar metals might cause deterioration of grounding surfaces are observed.

Below are lists of metals divided into groups. By avoiding the use of metals from one group attached to a metal of another group we prevent ground contact surface deterioration.

Group A	Group B	Group C	Group D
Magnesium	Tin	Stainless Steel	Copper
Aluminum	Lead	Nickel	Silver
Zinc	Steel	Iron	

Metal surface contact of metals in the same group may be used with the following stipulations:

CONTACT SURFACES	INSIDE	OUTSIDE (Weather Exposed)
Within same group	OK	OK
Adjacent groups	OK*	Weatherproof coating must be applied after direct metal-to-metal contact.*

* No liquid should be allowed to come into contact with surface gaps of metal contacts from adjacent groups.

1.8. CONNECTIONS

All ground connections shall be made with minimum length conductors, with straight vertical (or horizontal) runs, if possible. Conductor bends, when required, will be greater than 12inch radius. Connecting conductors will always transition in the direction of current flow or toward earth ground, and approach the main ground at an angle of roughly 45 degrees.

All exothermic protection connections made to the ground system, including test leads shall be made with an **exothermic** protection exothermic welding process specifically designed to restrict heat energy transfer to surrounding objects.

EXOTHERMIC OR PERMANENT GROUNDING CONNECTIONS

Exothermic power & grounding connections are made with a pre-engineered system using a controlled exothermic chemical reaction. exothermic connections offer the following advantages over other types of connections:

- The connection permanently welds every strand of the conductor.
- The connection is made with portable equipment which requires no outside source of heat or power.
- Loosening or corrosion of the current path cannot occur.
- The connection is able to withstand repeated high current surges [faults] without damage to the connection or the conductor
- No special skills and minimum training is required.
- Installation time is the same as other kinds of connector.

PERMANENT GROUNDING CONNECTION SPECIFICATIONS

All grounding conductor to conductor, conductor to ground rod and conductor to structure and fence post connections of #6 AWG and larger copper conductors shall be permanent exothermically welded connections. Copper grounding conductors spliced with exothermic connections shall be considered as a continuous conductor, as stated in NEC 250-81 Exception No. 1 and 250-91 Exception No. 3.

All connections shall meet the applicable requirements of IEEE Std 80-1986. For this reason, the CADWELD® exothermic connections are suggested as they are approved in NEC 250-81, -91, -113, and -115.

Welding material for copper-to-copper and copper-to-steel connections shall contain copper oxide, aluminum and

not less than 3 percent tin as a wetting agent. Starting material [if used] shall consist of aluminum and copper oxides. It shall not contain phosphorous or any caustic, toxic or explosive substance.

Weld metal shall be controlled at the point of manufacture and subjected to rigid quality control inspection procedures.

1.8.1. Below Ground

(**CADWELD®**) is a bonding process that provides a metallic bridge connection that exhibits virtually no resistance and its conductivity approximates that of the associated conductors). Connections made to ground rods, or to conductors below ground must be made using an exothermic process such as **Cadweld®** or equivalent. This attachment procedure ensures firm, mechanically rigid, and maintenance free connections. Connecting and interconnecting conductors are placed at the same depth as the top of the ground rods.

DOPING OF GROUND SYSTEMS

When unable to achieve grounds below 10 ohms, some doping of the earth may be necessary. One of the best methods used today to increase the conductivity (reduce resistance) of the ground is another CADWELD product called "GEM®." (**ERICO® GROUND ENHANCEMENT MATERIAL**) If **GEM®** is unavailable, a clay-salts compound called "BENTONITE" or "LYNCONITE" may be used. **ERICO®** Catalog A7J provides more detailed information. LYNCONITE is available from LynCole, the makers of the "XIT" ground systems. *If a more effective ground is needed, the "XIT" ground devices may fulfill this requirement (see Figure 11).*

APPLICATION

ERICO Ground Enhancement Material, GEM, is a superior, conductive material that improves grounding effectiveness regardless of soil conditions. It is an ideal material to use in areas of poor conductivity soil, such as rocky ground, mountain tops and sandy soil. **GEM is added around a ground rod in an augured hole or around a conductor in a trench.** The GEM material effectively increases the effective diameter of the rod or conductor.

GEM SPECIFICATIONS

Ground enhancement material shall be **ERICO GEM** having a constant cured resistivity of 12 ohm/cm or less. It shall set up to a hard, permanent material and shall not decompose or dissolve over time. It shall not require any maintenance after installation. It shall not rely on the continuous presence of water nor shall it add salts to the earth which may contaminate the ground water. The material shall be packaged in 25 pound bags and may be added dry or pre-mixed in a slurry like cement.

1.8.2. Above Ground

Where possible, connections made above ground, in areas exposed to weather, the Cadweld® or similar process will be employed. If environmental conditions prevent the use of the Cadweld® process, the use of an appropriate pressure-type connection will be used.

Where above ground pressure type connections are employed, stranded wire will be used. Connections made above ground will be made with appropriate passivation of the mating surfaces, or use special transition clamps such as *PolyPhaser Model J1, J2*, or equivalent.

Connections of stranded conductors to equipment racks is made using lugs or pressure clamps consistent with the wire size, and grounding surface of the equipment being grounded. Connections to tower guy wires will use pressure connections.

1.9. SURGE SUPPRESSION DEVICES

Manufacturer Surge suppression device types referred to in this document are recommended and may be substituted as long as the substitution is of the same quality and performs the same function. Consideration must be given to voltage clamping level, response time, and energy rating for the intended application. Power line surge suppressors similar to the PolyPhaser PM240-BP (*see figure 9*) should be included at the service entrance breaker panel. Other types that serve that provide similar service is the “E-CLIPS” and Joslyn.

1.9.1. The Following Practices Are to be Avoided!

- a) Ground wire runs through metal conduit. If an occasion presents itself where the ground must be carried through a metal conduit, the ground wire must be bonded at each end of the conduit. **The use of PVC conduit is preferred.** (Where the wire ground exits the communications room or shelter; *see appendix “A”, figure A1*).
- b) Reliance on the third wire (green wire) on ac power lines for lightning ground.

2. EXTERNAL GROUNDING SYSTEM

External grounding rings installed by Ericsson or approved contractors will individually encircle the antenna tower, the building, or equipment shelter.

Ground rods for the tower and building are installed so that the top of the rod(s) is minimum of 12 inches below soil surface. The ground rods for tower ground will be installed so that the bottom end of the rod is deeper than the lowest part of the tower footing.

Each ground ring listed above, such as the tower, building, fence, or other object will be interconnected with a minimum of two stranded copper wires number 2 AWG or larger. Where the “*PolyPhaser Earthed Entrance Panels*” (PEEP) is employed (*figure 8*) or the Andrew ARRESTOR-Port Plus (*figure 12*), copper straps will be prepared and connected as shown in *figure 10* and *appendix “B” figures B9 and B10*. Where possible, connections to the ground rings will be made using an exothermic (Cadweld process or equivalent; *see appendix “B” attached*) weld.

2.1. ANTENNA TOWER GROUNDS

Where monopole masts are employed, the ground system will consist of a minimum of three ground rods, connected together per the section on “Conductors: Below ground.”

The mast connection to the ground system will be made with stranded wire number 2 AWG or larger. Connections to the mast will be in accordance with the manufacturer’s instructions or use the exothermic “CADWELD®” method. The connections will be short and direct with no sharp bends. Typical interconnections are shown in *figure 5* attached to this document.

2.1.1. Wooden Antenna Poles

At installations where wooden antenna poles might be employed, the grounding system will consist of a minimum of two ground rods connected together and installed as per the paragraph “Conductors: Below ground.”

Atop the pole, ground connections to the antenna or antenna mast are made per manufacturer recommendations. A number 2 AWG or larger stranded copper ground wire will be run down the pole, and away from all other conductors to avoid possible flashover.

2.1.2. Self Supporting Lattice Towers

The self supporting lattice tower grounding system consists of a ground rod at each tower leg. If necessary, additional ground rods may be used to decrease ground resistance where needed, or be used to reduce the distance between rods. Ground rods must be connected together per paragraph “Conductors: Below ground.” Each tower leg is connected to the grounding system with number 2 AWG stranded wire or larger. Connections to the tower leg will be short and direct with no sharp bends.

2.1.3. Guyed Lattice Towers

The guyed lattice tower grounding system consists of three ground rods at the tower base. These ground rods must be connected together per paragraph "Conductors: Below ground." The ground conductors used connect the grounding system will be number 2 stranded wire or larger. Connections to the tower will be short and direct with no sharp bends.

In addition to the tower leg grounding, a ground rod must be installed at each guy anchor point approximately one foot from the anchor footing. The top of the ground rod will be a minimum of 12 inches below soil surface. The bottom of the ground rod will extend below the lowest point of the anchor footing.

Number 2 AWG stranded copper wire is used to connect each of the guy wires to the ground rod at the guy anchor. Each ground rod is to be tied back to the tower "ground ring" below ground, using number 2 stranded copper wire.

2.1.4. Antenna Support Structures On Buildings

Radio antenna installations atop buildings will have the tower, down conductors, transmission line shields, and other conducting objects within 6 feet of the tower or antenna base securely bonded together per paragraph "**Conductors: Above ground**" (1.7) and "**Connections: Above ground (1.8-1.82).**"

Atop steelframe structures, where possible, the common bond point may be bonded to building steel with number 2 AWG or larger, copper wire. If available, the tower may also be bonded at roof level to a large metal, earth grounded, cold water pipe.

Atop reinforced concrete buildings, the common bond point should be connected via number 2 AWG or larger, stranded copper down conductors. These may be bonded to the earth grounded cold water main in the basement of the building or bonded to the building ground system. If available, the tower should also be bonded at roof level to a large metal, earth grounded, cold water pipe.

IMPORTANT NOTE

Guy wires associated with towers atop buildings should be grounded at their anchor points to a common bond point in the same manner as for grounding terrestrial towers. A dissimilar metal interconnect device will be used between the guy wire and the ground wire. Where the ground wire from multiple guys are daisy-chained, there will be at least a three inch "play" loop between guy-to-guy ground connections. In the above case where tall building grounds are in use, the ground resistance should be maintained below (better than) ten (10) ohms between any equipment connected ground buss and earth ground. When making these measurements, an instrument similar to the AEMC Model 3700 HD will be used to make these measurements. The measurements will be made using the instructions provided with the AEMC 3710 (ERICSSON cat # LYAEMC_3710) Ground Test Instrument.

2.2. EQUIPMENT BUILDINGS

External "halo" ground is the grounding system around the exterior of the communications shelter or building. This ground system consists of a ground rod at each corner of the building. As necessary, additional ground rods will be added such that the distance between rods is less than 10 feet.

A ground rod is installed directly below the coax transmission line entrance to the building. Ground rods are spaced approximately 2 feet out from the perimeter of the building.

2.3. BULKHEAD PANEL

A weatherproof metal bulkhead panel should be installed on the building equipment wall (see figure 10). The panel will be comparable to the *Andrew ARRESTORPORT* Plus or the "PolyPhaser Earthed Entrance Panels" or "PEEP" (see appendix "B" figures B6 and B7 and/or figure 8) models (photos and drawings are a part of this document). The size should be determined by the number and size of transmission lines interconnecting through it (figure 8 shows dimensions). Insure that appropriate cable boots are used to weatherproof the connections.

The external panel must include a ground bar for transmission line shield ground connections and connections to the external ground system (see figure 10 and appendix "B" figure B9). The ground bar should be fabricated to avoid dissimilar metal connections as stated in this document (see appendix "A" figure A3 attached; see also paragraph "Conductors: Above ground."). The ground bar (appendix A, figure A3) must be connected to the building external ground

system by number 2 AWG (2 conductors or copper straps may be employed to form a low inductance path to the system ground).

An internal sub panel is not necessary when using the *Andrew ARRESTORPORT Plus*. Several features are built into the *Andrew ARRESTORPORT Plus* that eliminate additional connectors and options that are associated with the *PolyPhaser Earthed Entrance Panels*. The *Andrew ARRESTORPORT Plus* & the *PolyPhaser Earthed Entrance Panels* (see appendix "B" figure B7 & figure 10), bolted directly to the bulkhead panel with multiple bolts may be used to mount the transmission line surge suppressor specified in paragraph "Quarterwave stub & Coaxial Suppressor." The subpanel must be securely fastened with a low resistance, low inductance path to the bulkhead panel (stranded No. 2/0 AWG or larger).

2.4. FENCES

Where possible to do so, metal fences within 6 feet of any ground ring or any grounded object will be grounded at twenty foot intervals along its length or at a minimum of each corner post and at each gate metal support post. This is to provide additional shock hazard protection from lightning. Fences which are around the site, yet outside 8 feet of the perimeter grounds should be grounded at fifty (50) feet intervals along its length.

A minimum 8foot 5/8 inch copper or copperclad ground rod shall be installed into the ground within one foot of the fence, near a fixed gate hinge post where appropriate. The top of the ground rod will be a minimum of 12 inches below the ground surface (see figure 3 & 4 for similar connections) or at the same level as the external ground ring to which it will be connected. Additional ground rods may be installed for each 50 feet of fence, at equal spacing outside 6 feet of the ground system but surrounding the facility.

Each ground rod will be connected underground by the most direct path to the nearest tower or building ground ring using a stranded copper wire, number 2 AWG or larger (see figure 3).

Above ground connection will be made by use of exothermic weld or a pressure clamp near the bottom of the metal post. If below ground connections are used, it will be made by exothermic weld (**Cadweld®**). Tinned copper ground strap (braid) is used to connect metal fence gate(s) to the main post. Pressure clamps are employed with these connections.

2.4.1. Nearby Metal Objects;

The following components are connected to the external grounding system using a number 2 AWG (or larger) stranded copper wire.

- a) The transmission line entry window into the building, as this is the entry point into the equipment area. All transmission lines are grounded to this window, and extra care is employed to ensure a very low inductance path to ground.
- b) Ice shield and exterior cable tray between tower and building.
- c) Emergency generator and any generator supporting platform or base.
- d) Fuel tank(s), above or below ground.
- e) Other large metal or conductive objects within 6 feet of the communications shelter, tower, or the system ground.
- f) To other ground systems provided by telephone company, or the electric utility provider(s). Local electric codes should be observed when making this attachment.

2.5. TRANSMISSION LINES

The following applies to the antenna and transmission lines outside the communications shelter or building where entry is made into the equipment shelter (see appendix "B" figure B6). These requirements do not apply to antenna and transmission lines that are contained entirely within the equipment room or communications shelter.

2.5.1. Shield Grounds

The outer conductors of coaxial transmission cables must be grounded with an appropriate coaxial cable grounding kit (see figure 13 and appendix "B" figure B12). These grounding kits are installed at three points on the cable. The grounding locations are as follows:

- 1) Immediately outside the cable entrance to the equipment room, shelter, or building. This ground is attached prior to the phaser type lightning suppressor.
- 2) At the bottom of the vertical run of cable, at a point near and above the bend onto the icebridge or support tressel. This grounding point should be as near the ground as possible.
- 3) The top end of the vertical cable run near the termination or antenna. This point is grounded or bonded to the tower by means of the clamp supplied as part of the grounding kit.

All three points should be grounded in accordance with the recommendations provided in the grounding kit instructions. These instructions are included in kits similar to the *Andrew cable grounding kit described in figure 13*. The *PolyPhaser UNI-Kit is shown in Appendix B, figure B11 and B12*.

Additional information is shown at points labeled 1, 2, & 3 in *figure 1* of this document.

2.6. COAXIAL SUPPRESSOR

Quarterwave shorted stub or Coaxial Suppressors should be installed at cable entrance of the building or communications shelter. This suppressor should be bonded to the nearby ground bus plate to remove surge currents from the center inductor of the cable(s).

2.7. TOWERTOP PREAMPLIFIERS

In cases where towertop amplifiers are employed that use DC supplied via the coaxial transmission line, *Ericsson* will insure that an impulse suppressor similar to the *PolyPhaser ISDC50LN DC "injection"* type is used. Certain tower top amplifiers are already equipped with this type protection (see figure 2).

PolyPhaser type ISGC50LN "pick-off" surge suppressor should be installed according the manufacturers instructions as an additional protective measure at the input ports of the towertop amplifiers or preamplifiers. This protection is in addition to the Ericsson internal amplifier protective devices. All towertop preamplifier chassis must be grounded to the tower.

IMPORTANT NOTE

Where the ANDREW ARRESTORPORT Plus is installed, no quarterwave shorted stub can be used in the coax where power is being fed to a tower-top amplifier. Provisions are made in the ANDREW ARRESTORPORT Plus to accomodate feeding tower-top amplifiers using the method shown in figure 2.

Where penetration of cable entry bulkheads are a part of the coaxial cables between the tower top amplifier and the Ericsson communications equipment, an added protection device may be required. The *PolyPhaser IS-DC50LNZ* pick-off and re-injector (PICKOR) may be employed. *Figure 2* provides illustrated details for the installation of these PolyPhaser DC insertion and DC pick-off devices.

Where possible, *DC ground*, shuntfed antennas should be used as additional protection for the towertop preamplifiers. Antenna cable attachments to the antennas are kept as short as possible.

2.8. TOWER-MOUNTED MICROWAVE AND REPEATER EQUIPMENT

For tower top repeaters, the input and output points are the most important to protect. Tower, telephone or control lines are often overlooked. Coax line protectors are employed in the Ericsson repeater inputs and outputs, and the preamp front end. Power line protectors must be local and single point grounded at the top with the equipment. The need for power protection is doubled for tower top repeater and preamp installations where 120 or 240 VAC is being fed up the tower.

Above 18 GHZ, microwave equipment usually has a *Gunn* (microwave diode) down converter located on the back of the dish, being powered through one or two coaxial lines. These lines also handle the uplink and down link frequencies as well as AFC (Automatic Frequency Control) error information.

Protectors similar to the *Poly-Phaser IS-MD50LNZ* should be employed at the top and bottom to properly protect the equipment. A device similar to the *PolyPhaser IS-DC50LNZ* is another type of protection used in these applications and is fully transparent to all existing voltages and signals from microwave equipment.

2.9. COMMUNICATIONS EQUIPMENT ROOM INTERNAL GROUNDING

A Halo ground should be employed inside the communications shelter. This Halo ground must be installed in the form of a "ring" in such a manner as to enable the use of short length conductor to be attached at the same ground window as the equipment racks, cabinets, cable trays, and equipment shelves.

This Halo is made of number 2 AWG stranded copper wire attached to standoffs (see appendix A, figure A2) at approximately eight (8) feet above the equipment room floor.

Where the room or communications shelter has less than 100 feet of perimeter, a minimum of four (4) ground risers are used. In any case, where possible, a ground riser is used at each corner of the perimeter (see appendix A, figures A1 & A2) . In installations where the perimeter of the equipment room exceeds 100 feet, a ground riser will be attached at every twenty (20) feet of perimeter (see appendix A, figure A2). These ground risers are made of number 2 AWG *SOLID* copper which exit the room, or building via **polyvinyl conduits** (see PVC exit method in appendix A, figure A1).

2.9.1. Grounding Of Equipment Cabinets, Racks, And Shelves

Each equipment cabinet or rack shall be equipped with a ground bus that is attached to the main ground window and the external system ground. Each equipment chassis secured in a cabinet or rack is connected to the cabinet or rack, ground bus. Equipment mounting rails are the preferred ground connection points within the cabinets or racks. Attachments from the equipment cabinets and enclosures to the internal ground window are made using number 6 (or larger) stranded copper wire (see *figure 10*). Connections from these enclosures to the main ground window will be made using the shortest path length to diminish inductance.

2.9.2. CABLE TRAYS

Cable trays will be attached to the internal ground window via number 2 AWG or larger stranded copper wire. Where mechanical connections (lugs, bolts) are made to interconnect cable tray sections, an additional connection will be employed between cable tray sections (see insert text at figure 1) to ensure a good electrical ground connection (see appendix A, figure A4). Number 6 or larger, stranded copper wire will be used.

Grounds between cable trays, equipment cabinets, equipment racks, and AC utility power enclosures will be via number 2 AWG or larger stranded copper wire.

When compression type connectors are employed at an *Ericsson* installed site or system, the Burndy compression

system (or similar) may be used. This system consists of connectors for indoor taps, splices, and structural steel termination's. These connectors may be used in some *Ericsson* sites ground applications. The Burndy system connectors are listed with *Underwriters Laboratories under Standard UL467*.

3. PLANS AND DOCUMENTATION

Drawings and Ground reference documentation will reflect the following items:

- a) Grounding and bonding plan
- b) Ground rods
- c) Surge suppression devices
- d) Bulkhead panel types
- e) Coaxial cable grounding kit(s)

A prepared plan for lightning and surge protection measures implemented into an *Ericsson* communications system is submitted as a part of the overall system specifications. This plan takes into account such items as the radio installation and equipment to be protected and local conditions. This plan must meet all requirements covered in this specification, unless a specific written waiver is provided by the customer and agreed by *Ericsson*.

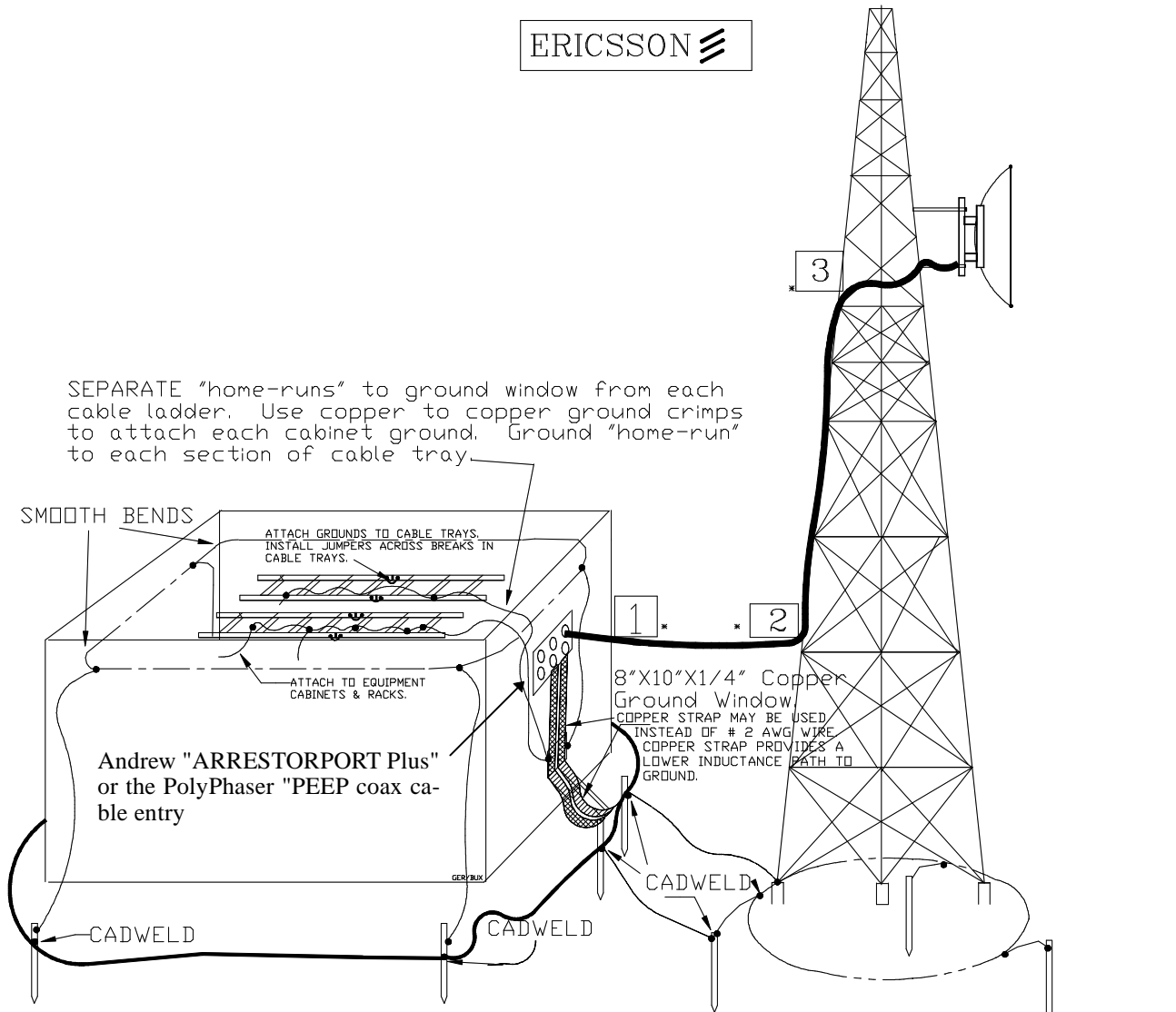

SEPARATE "home-runs" to ground window from each cable ladder. Use copper to copper ground crimps to attach each cabinet ground. Ground "home-run" to each section of cable tray.

SMOOTH BENDS

ATTACH GROUNDS TO CABLE TRAYS. INSTALL JUMPERS ACROSS BREAKS IN CABLE TRAYS.

ATTACH TO EQUIPMENT CABINETS & RACKS.

Andrew "ARRESTORPORT Plus" or the PolyPhaser "PEEP coax cable entry

8"X10"X1/4" Copper Ground Window
COPPER STRAP MAY BE USED INSTEAD OF # 2 AWG WIRE. COPPER STRAP PROVIDES A LOWER INDUCTANCE PATH TO GROUND.

CADWELD

CADWELD

CADWELD

Attach ground rods to inside HALO with smooth bends and using # 2 solid copper. Make all bends flow in the same direction at all four corners. Do not allow ground wire to contact other metal conduits or cabinets between HALO and outside ground rod(s).

- 1 Attach ground at entry point to building.
- 2 Attach ground to shield when coax begins vertical run upwards.
- 3 Attach ground to coax shield at top of vertical run before coax bends away from tower. Keep all bends smooth, NO SHARP BENDS, this also applies to ground leads.

* USE "ANDREW" Grounding kit recommended for coax size specific to site application.

FIGURE 1

This drawing illustrates some of the grounding techniques described in this document. In addition it depicts how the inside and outside "HALO" grounds are interconnected. Note that all wire bends and turns in the "HALO" ground ring are smooth with no sharp points or bends. This same rule applies to the wires (shown in corners of the communi-

cations room) that interconnect the internal "HALO" to the outside ground ring.

Note also that a copper cable entry bulkhead (PolyPhaser "PEEP") and copper strap (2, 4, or 6 inch widths), may be substituted for the inside copper ground bar and the # 2 or 2/0 copper exit wire.

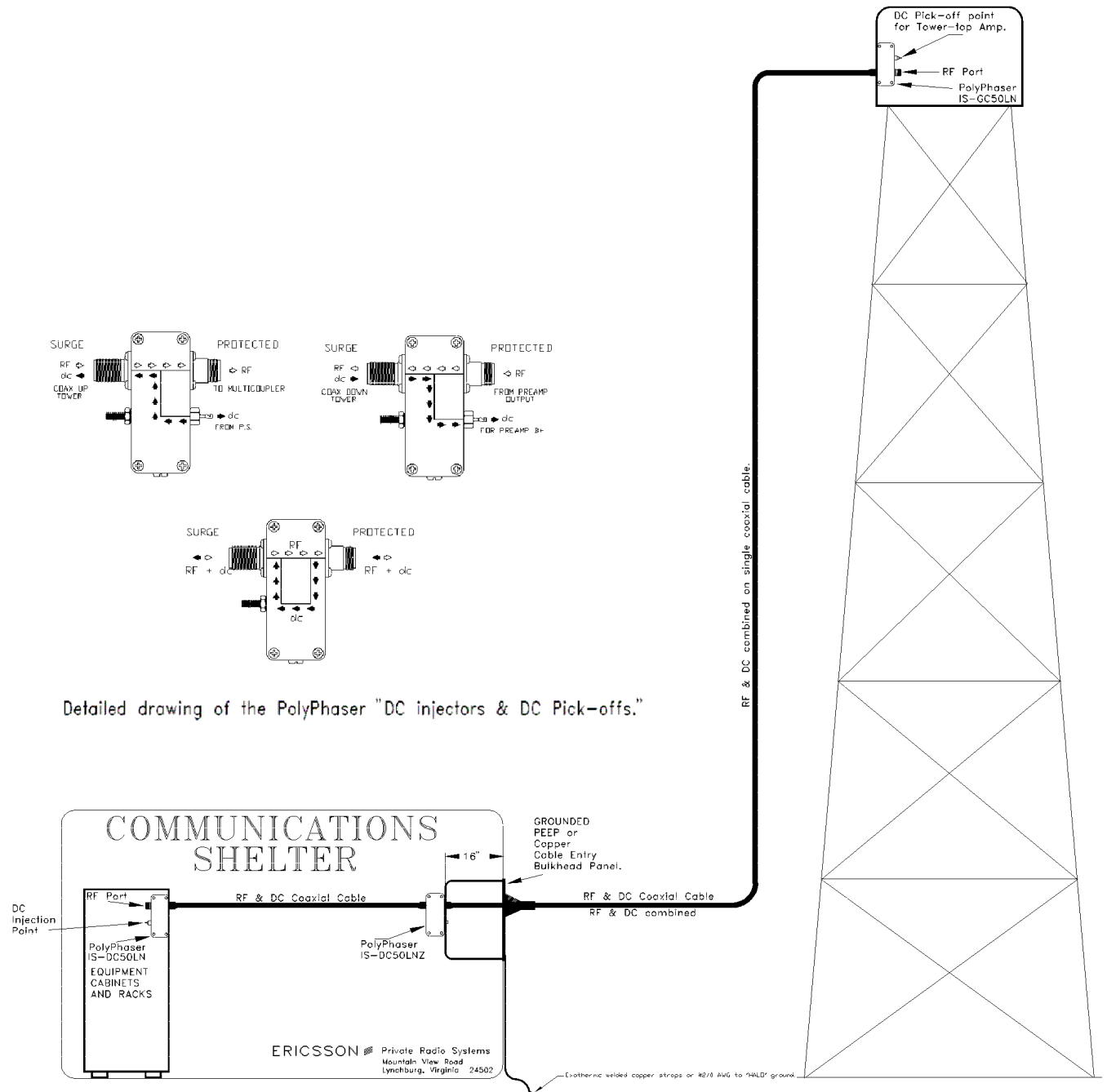

Detailed drawing of the PolyPhaser "DC injectors & DC Pick-offs."

FIGURE 2

This figure depicts the method employed when supplying DC voltage to tower-top amplifier(s) using the PolyPhaser injection and pick-off devices.

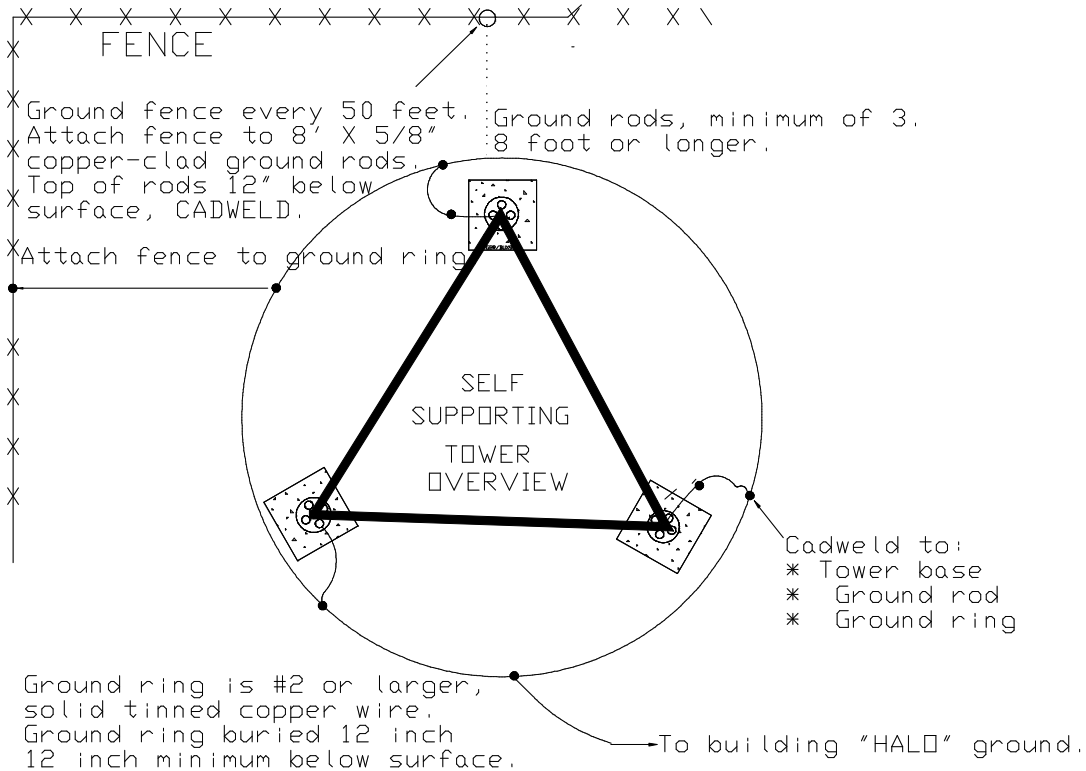

FIGURE 3

This drawing illustrates a typical transmit/receive site. Note areas of fence which come in close proximity to the tower and building grounds. All grounds are connected together. There are no separate ground systems at the same location.

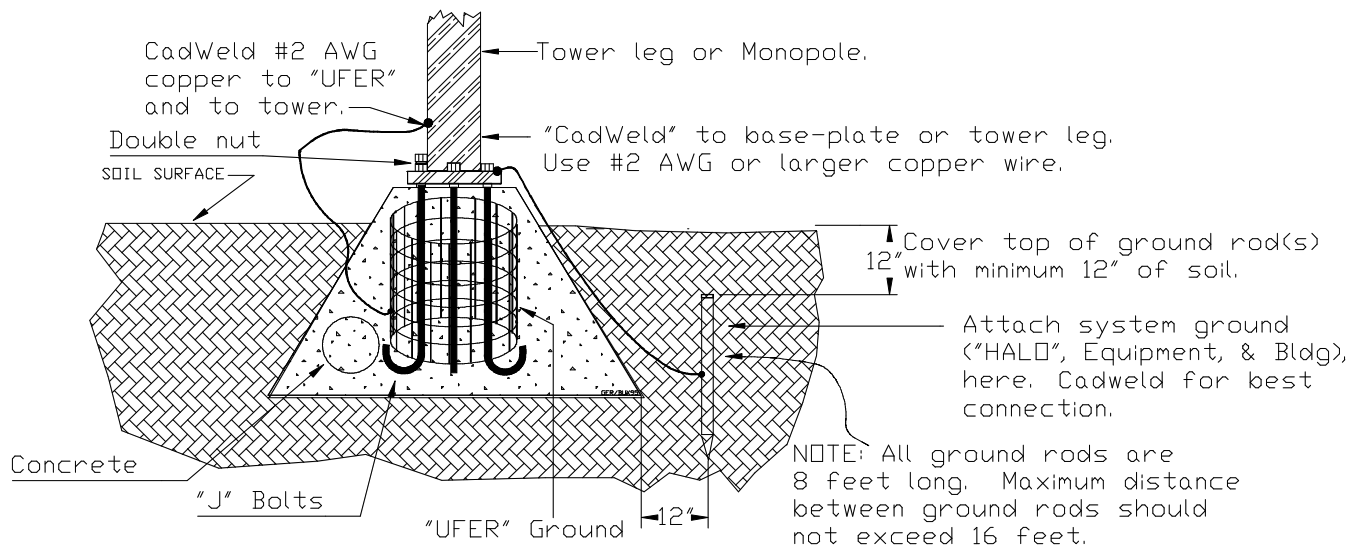

FIGURE 4

"UFER" ground refers to steel and metal bars imbedded into concrete floors or tower foundations. The "UFER" ground should never be relied as the exclusive or stand-alone site ground system.

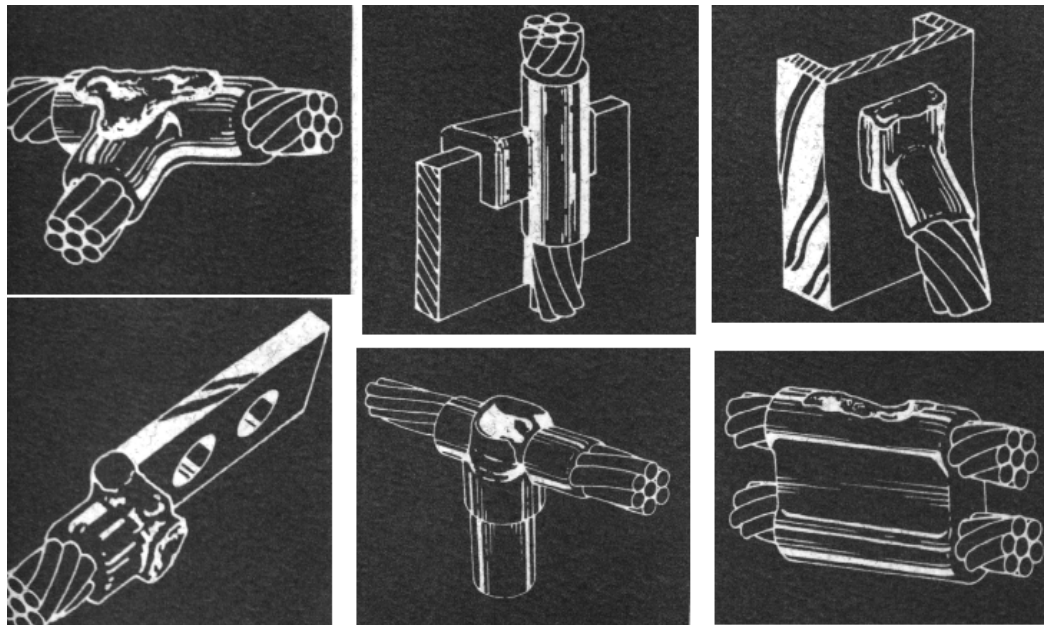

FIGURE 5
Typical “exothermic” welds made using the CADWELD method.

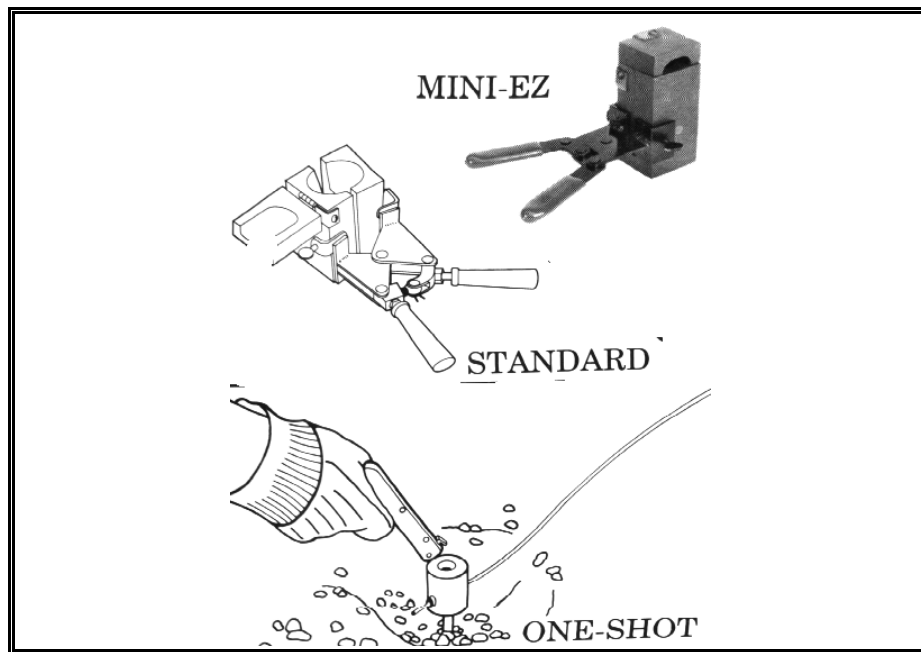

FIGURE 6
Examples of the tools used to make exothermic welds

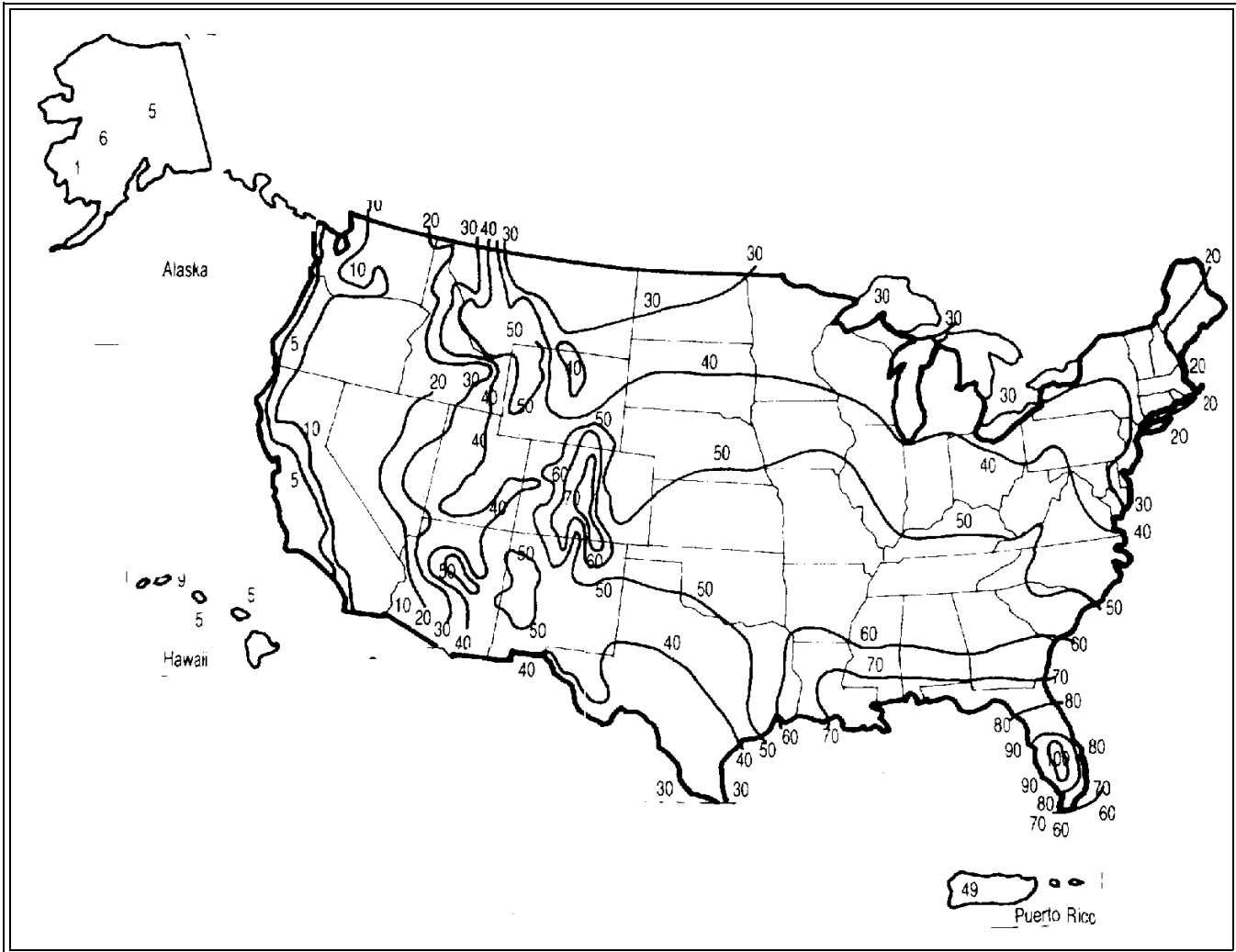
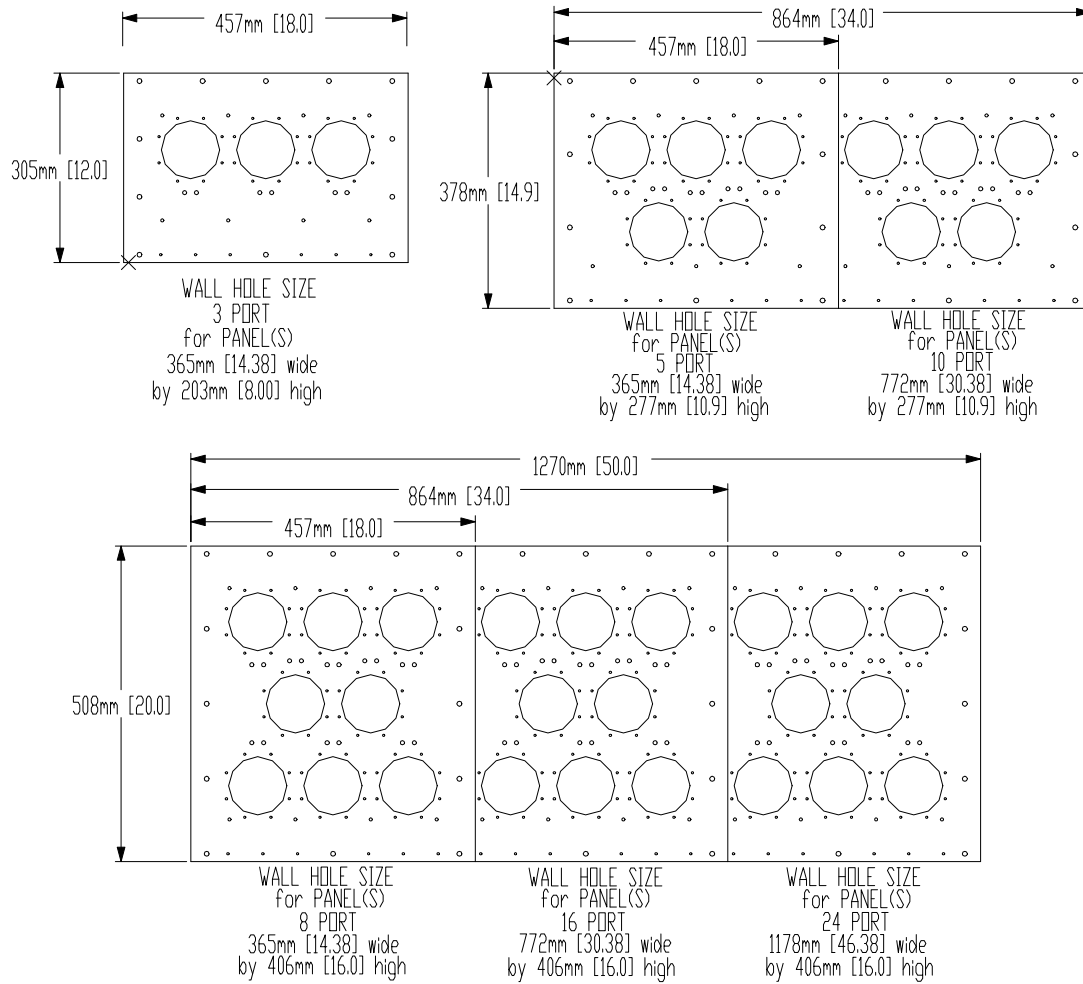

FIGURE 7

The isokeraunic map shown here shows mean annual number of days with thunderstorms in the United States.
NOTE: The region with the highest frequency is centered around south and central Florida.



TYPICAL INSTALLATION

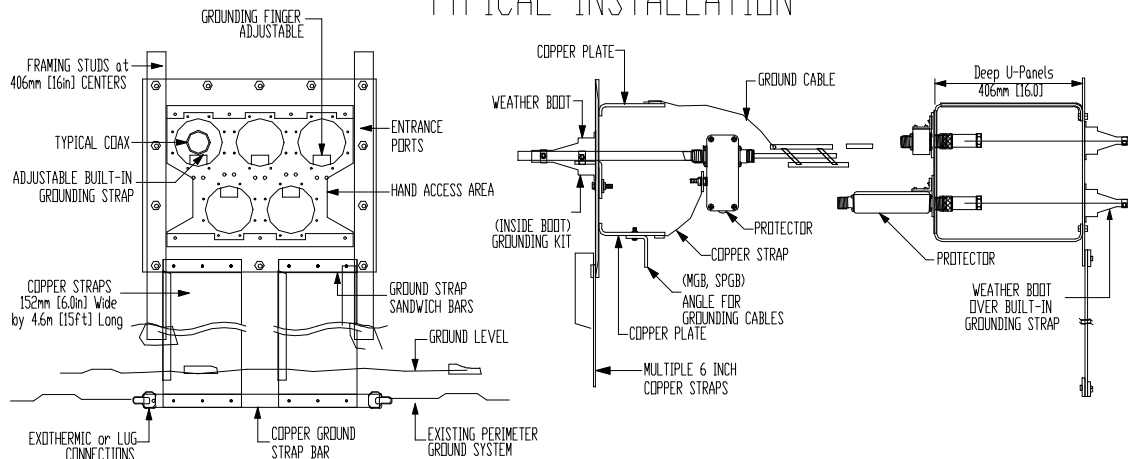

FIGURE 8

Typical installation of the PolyPhaser "PEEP." Where walls exceed a usable depth, an inside and outside panel may be installed. Use number 2 or 2/0 stranded wire as a bond between the inside and outside panels.

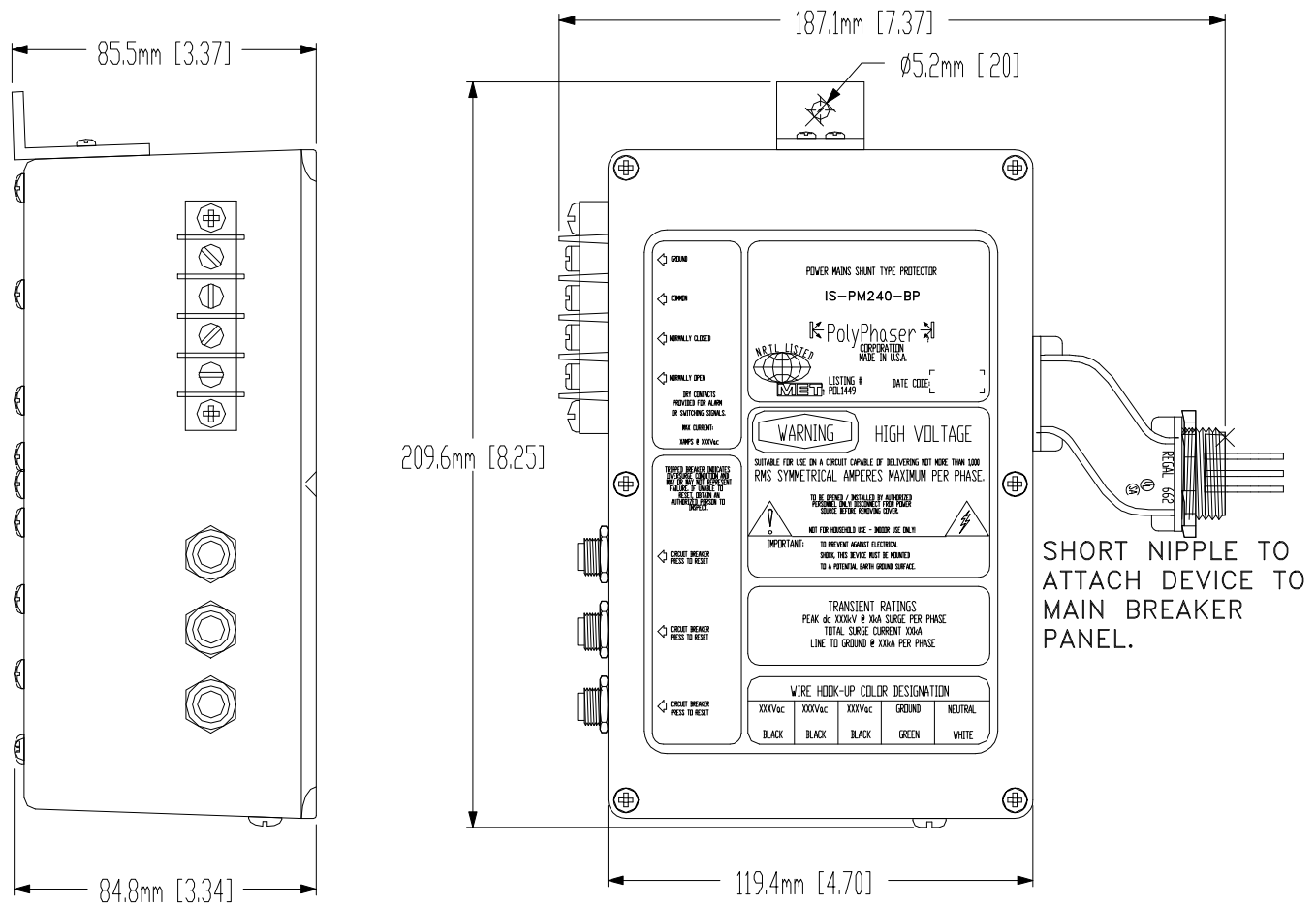

FIGURE 9

The device shown here is an example of the MOV type used to clip or suppress power surges that could otherwise damage equipment. Other types similar to the above are manufactured by “E-CLIPS” and Joslyn. (see sections 1.2 & 1.9 of this document).

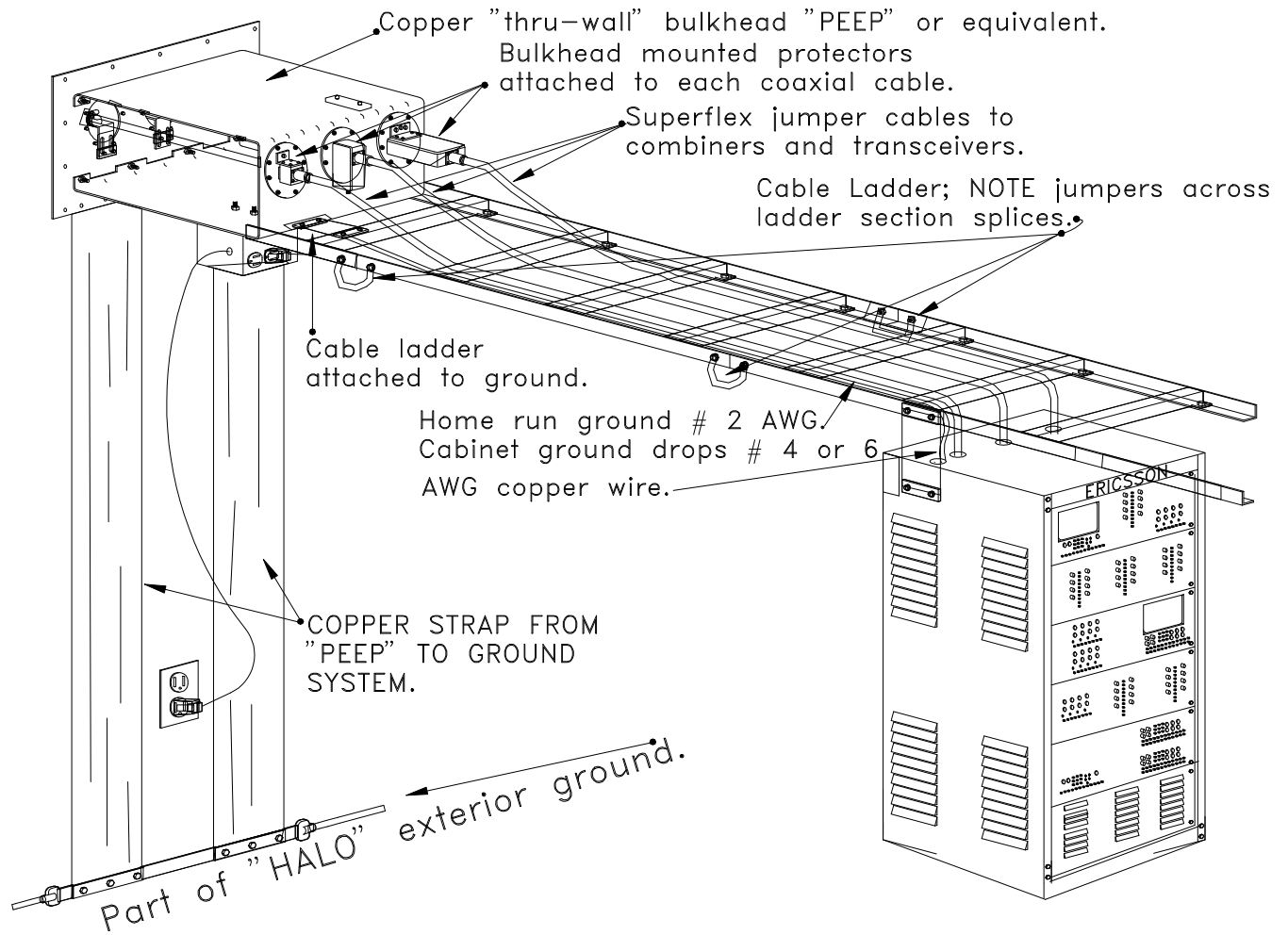
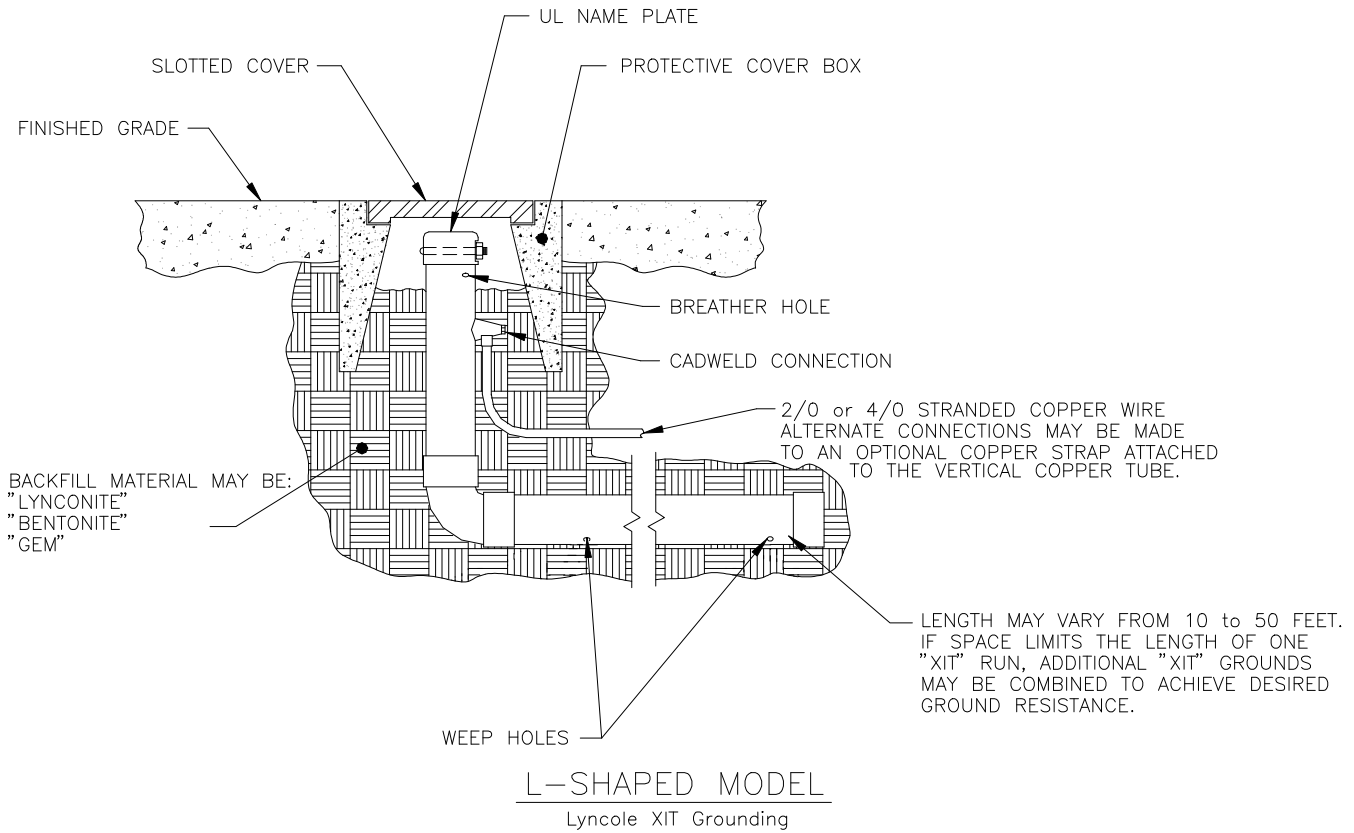

Figure 10

This drawing illustrates methods employed when attaching grounds and cable protective devices in an Ericsson installation. Note that some installations will have copper strap between the bulkhead entry panel and the "HALO" ground ring. By using multiple conductors of # 2 AWG copper wire or 4 to 6" wide copper strap, inductance in the ground conductor is greatly reduced. In some installation the Andrew Arrestor-Port-Plus may be installed to enable easier access to the entry port coaxial connectors or where the desire to use "DIN" type connections (800 MHz). Use of the Arrestor-Port-Plus reduces the number of connectors required for entry and grounding.



XIT
FIGURE 11

ARRESTOR-PORT Plus CONFIGURATIONS:

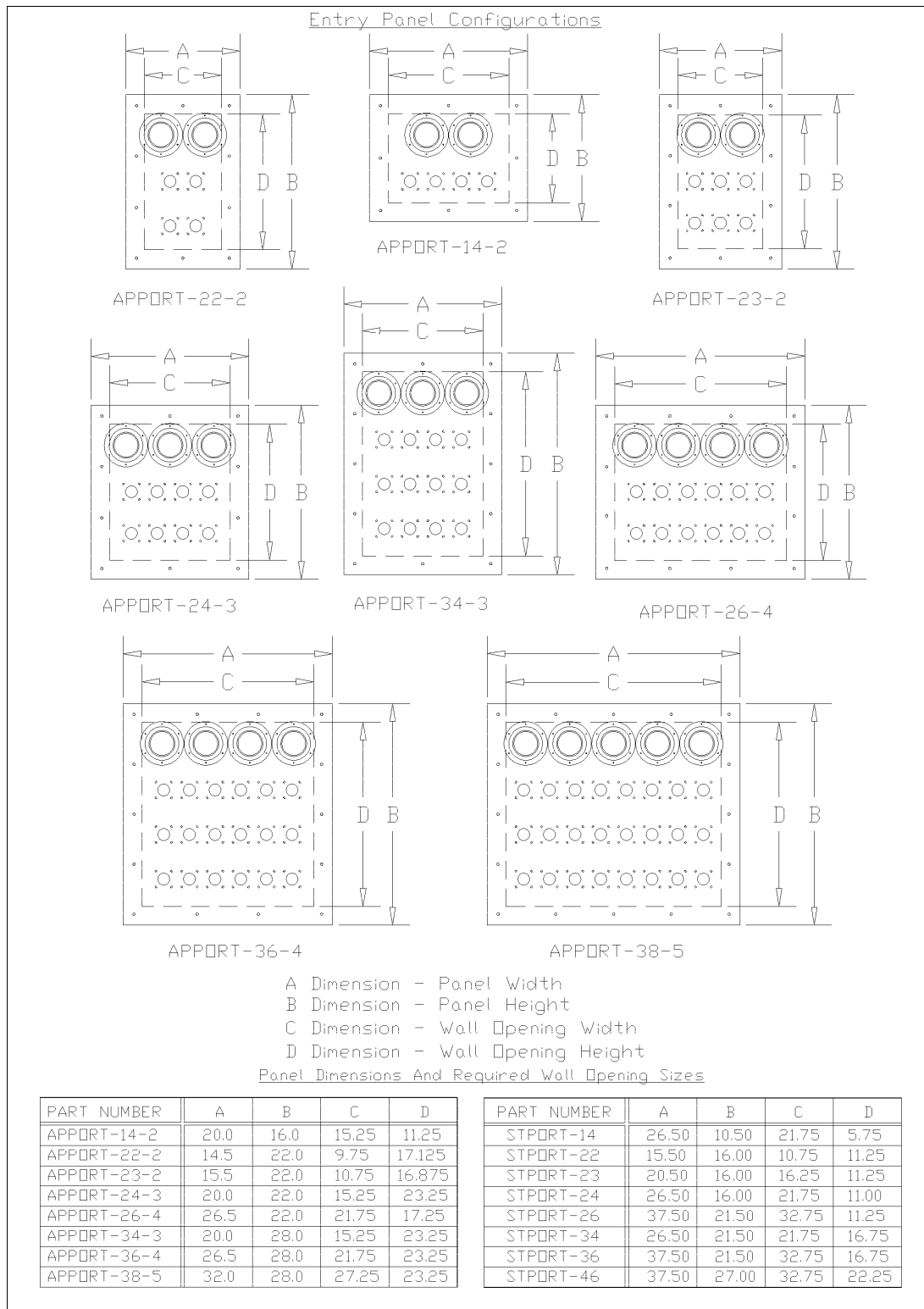
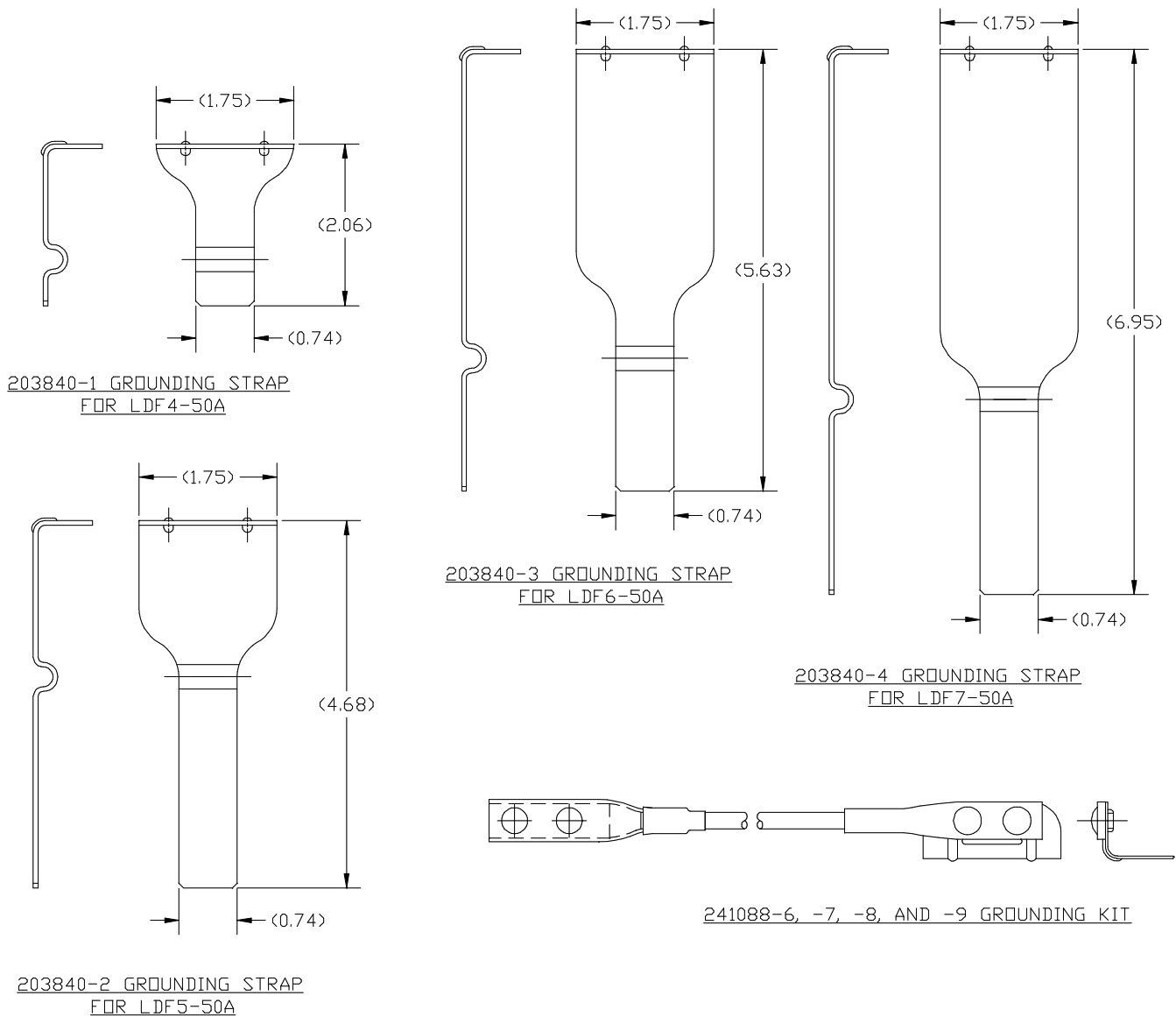

FIGURE 12

Andrew ARRESTOR-PORT Plus configuration and dimensions



GROUND KITS

FIGURE 13

Andrew cable “ground kits” for use when making 3 point ground connections at cable entry, tower base and tower top. For cables that exceed 200 feet vertical run, include additional ground attachments at 100 foot intervals. For three point tower ground illustration see figure 1.

Appendix “A”

THE DRAWING SHOWN HERE DESCRIBE METHODS USED TO ATTACH INSIDE "HALO" GROUND RING TO THE EXTERNAL GROUND RING (HALO).

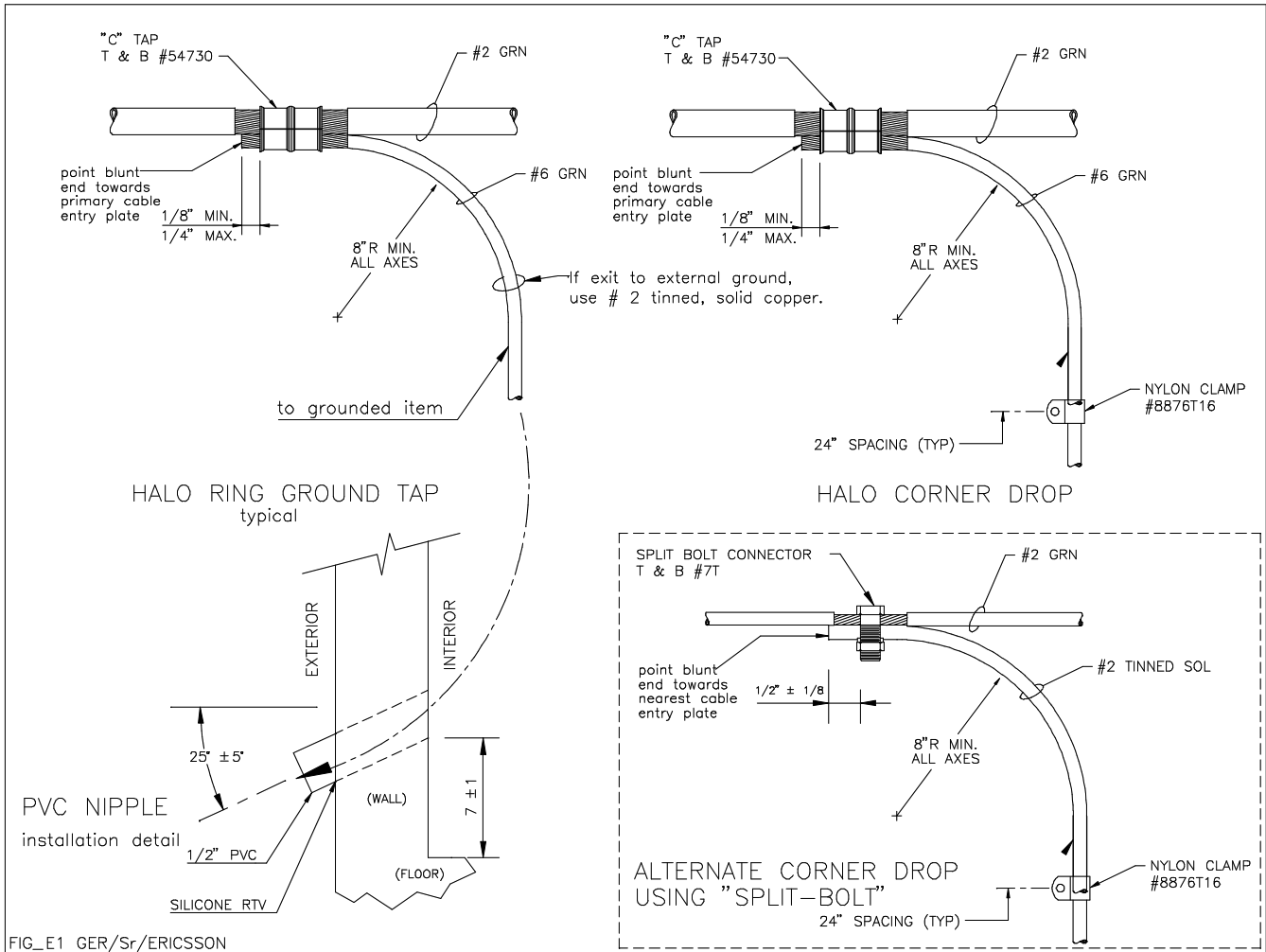

FIG_E1 GER/Sr/ERICSSON

FIGURE A1-"HALO" Attachments

NOTE: The PVC nipple is filled with silicone rubber or a sealant as a moisture barrier and pest deterrent.

THE DRAWING BELOW ILLUSTRATES VARIOUS MEANS OF CONNECTING TO THE INTERNAL "HALO" OR GROUND RING. THE DROP AT "A" DENOTES THE MANNER T&B CRIMPS ARE USED TO ATTACH AN EXIT GROUND DROP FROM THE INSIDE "HALO." THE DRAWING AT "B" MAKES USE OF A BETTER CONNECTION USING THE "CADWELD" OR EXOTHERMIC CONNECTING METHOD.

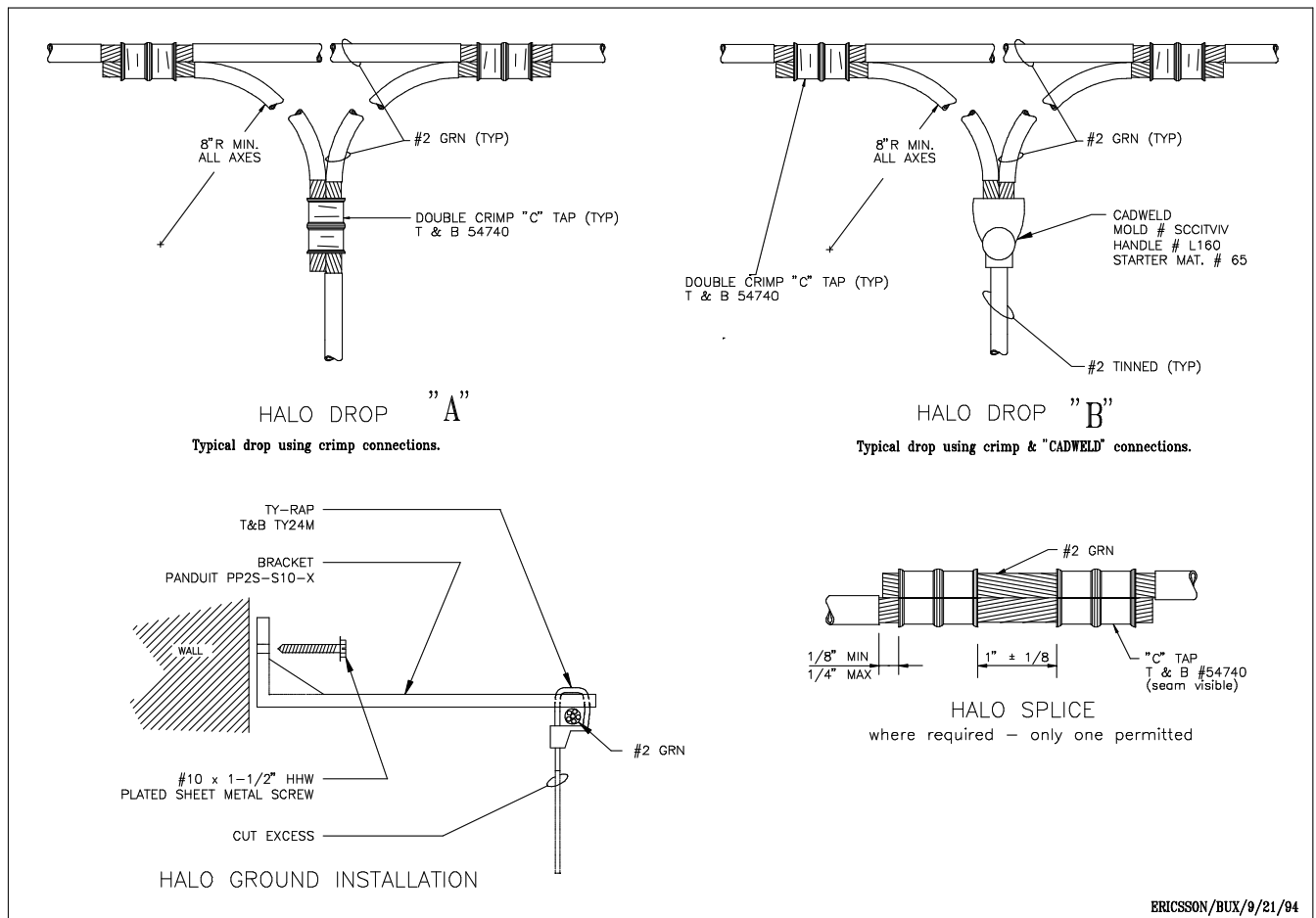

FIGURE A2-Internal "HALO" connections

NOTE 1 : Only one "HALO" splice may be installed per ground ring. Other attachments are to be made using the drop connections shown in these drawings.

NOTE 2: The illustration "HALO GROUND INSTALLATION" depicts one method used to attach the inside "HALO" to the wall.

When using a copper ground bar as a common point for internal shelter grounding, use one of the two methods shown below to attach the ground bar to communications shelter wall.

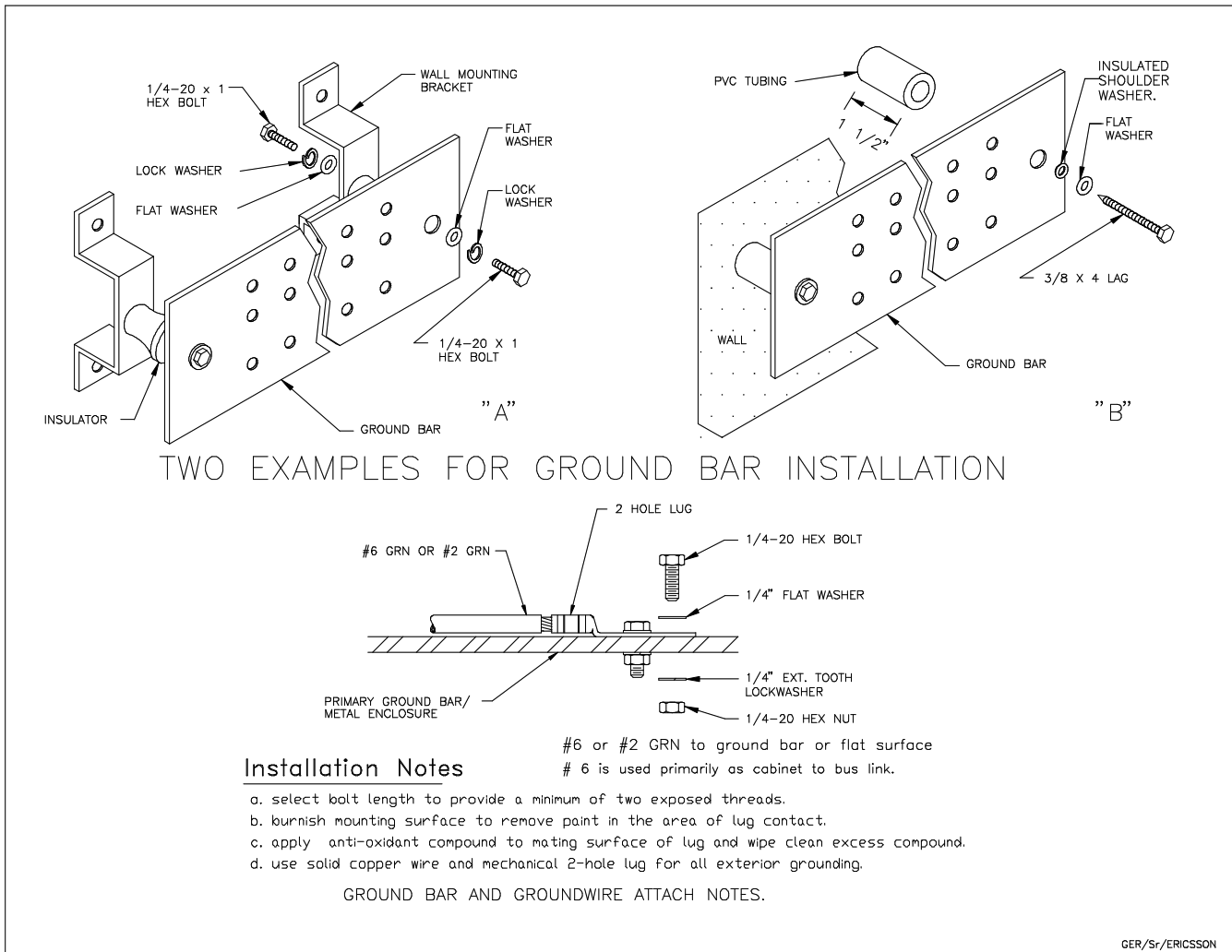

FIGURE A3-Two Examples Of Ground-Bar Installations

Note: At "A" insulators are used to support ground bar, while insulated "shoulder washers" are use at "B" to support the ground bar. In either case, the ground bar should be isolated from the shelter walls, support members, and studs.

THIS DRAWING ILLUSTRATES VARIOUS TECHNIQUES USED WHEN BONDING CABLE TRAYS AND METAL DOORS. THESE CONNECTIONS ARE NECESSARY TO PRESERVE GROUND INTEGRITY TO ALL METAL OBJECTS WITHIN THE COMMUNICATIONS SHELTER

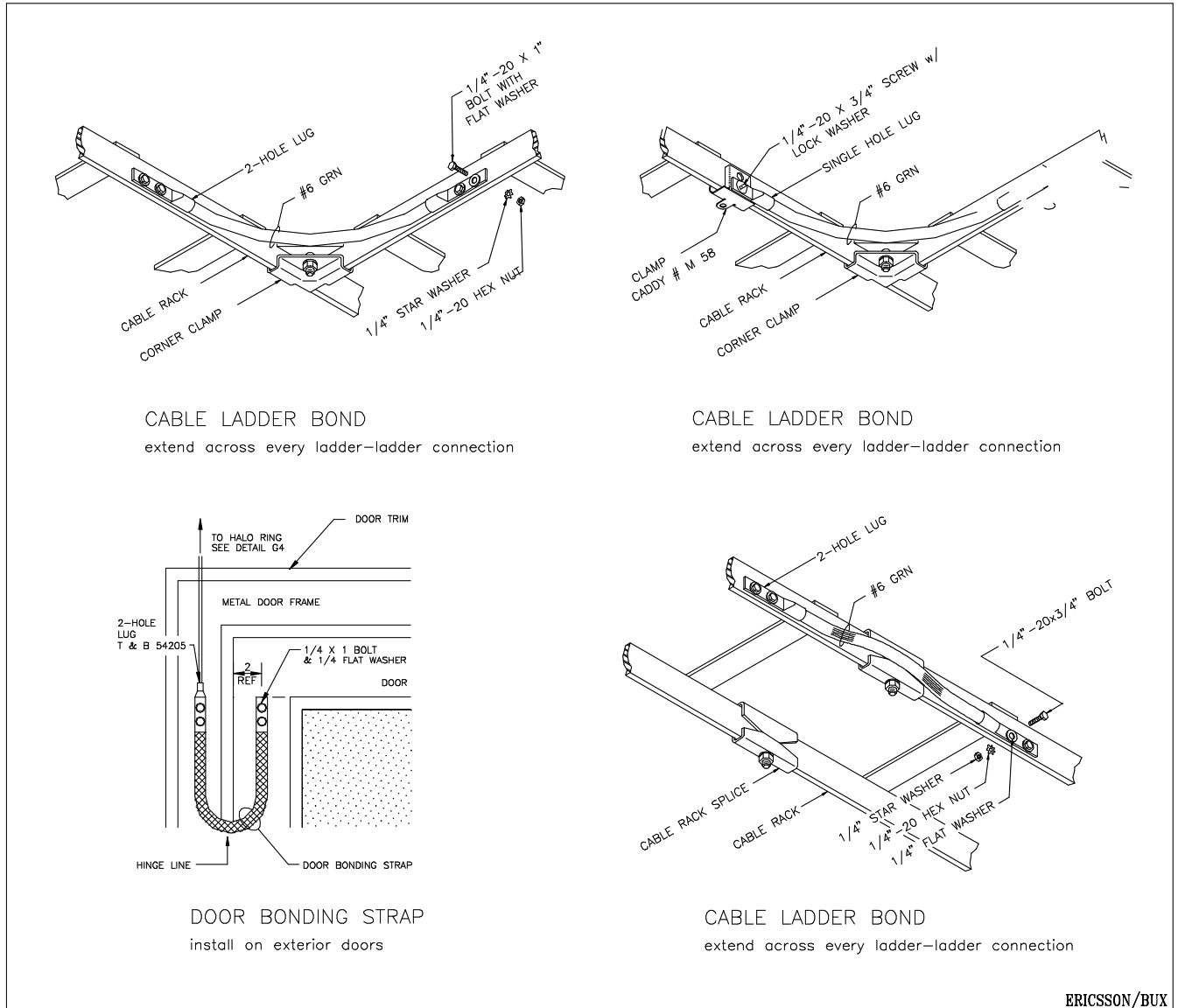

FIGURE A4-Cable Ladder and Door Grounding

This drawing illustrates typical conduit grounding examples.

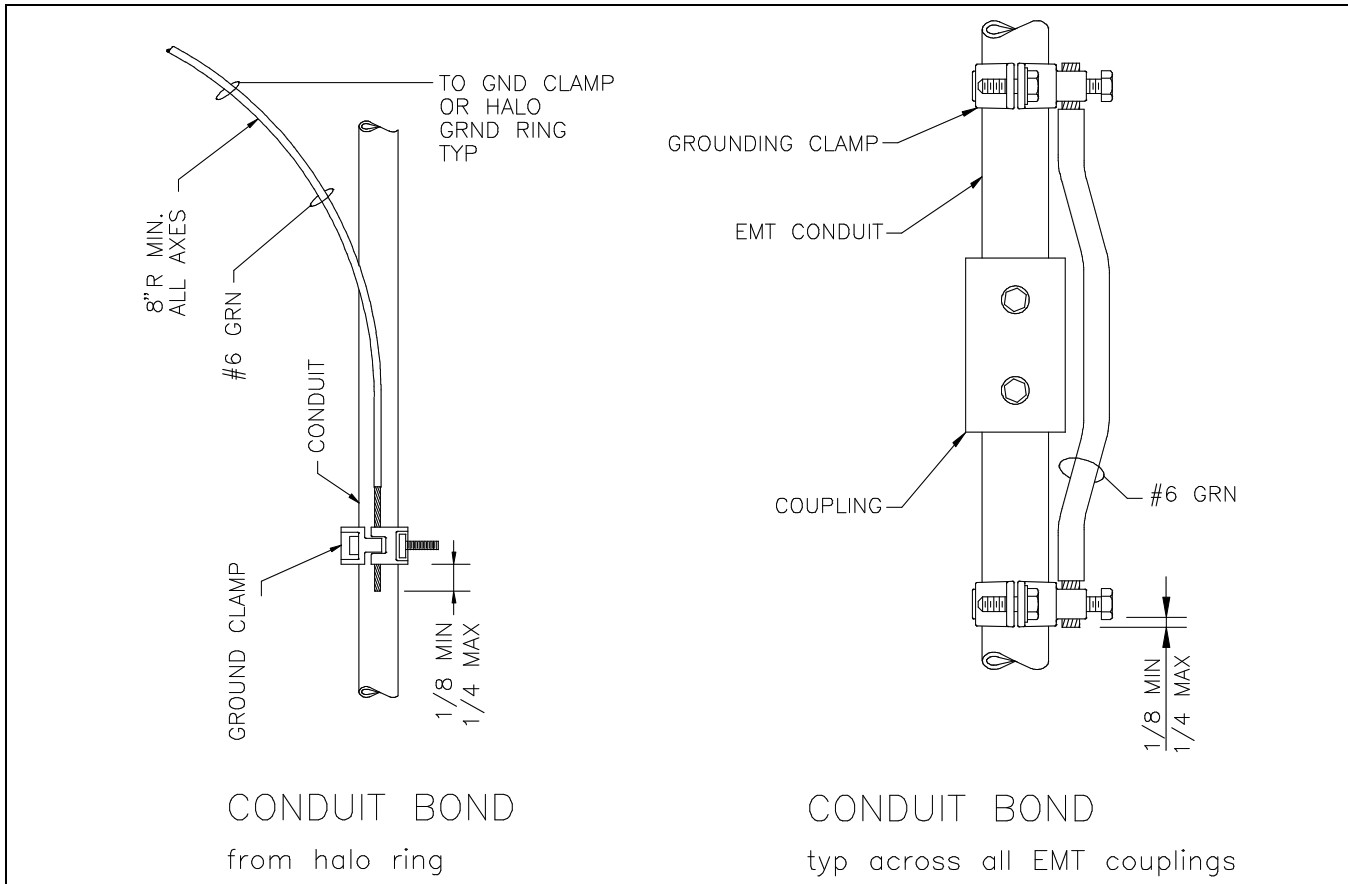

FIGURE A5-An Example Of Conduit Bonding

NOTE: no sharp bends in ground wires or conduits can be tolerated. ALL bends and turns shall be smooth.

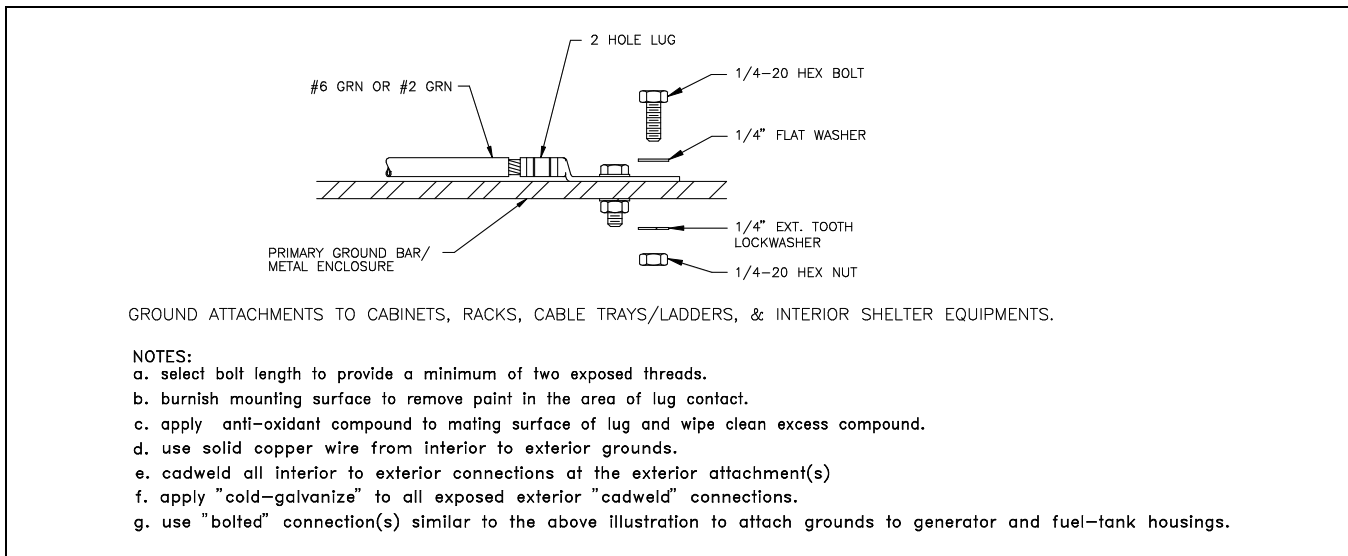

FIGURE A6-Example Of Inside Cabinet Ground Attachment

The drawing shown here illustrates how attachments are made to equipment cabinets and racks inside the communications room.

Appendix “B”

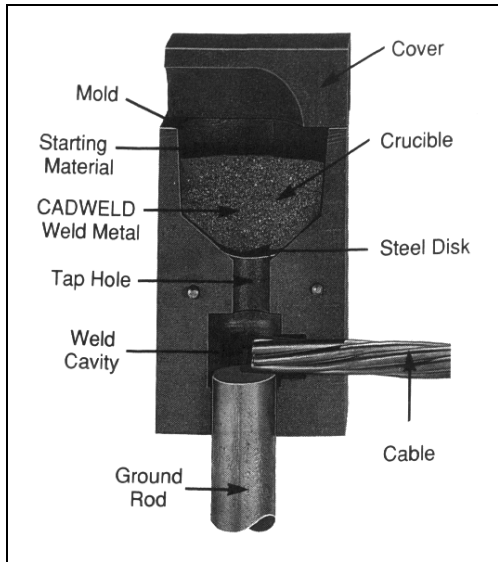

Photo courtesy CADWELD®

Figure B1 - Illustration of the exothermic welding process.

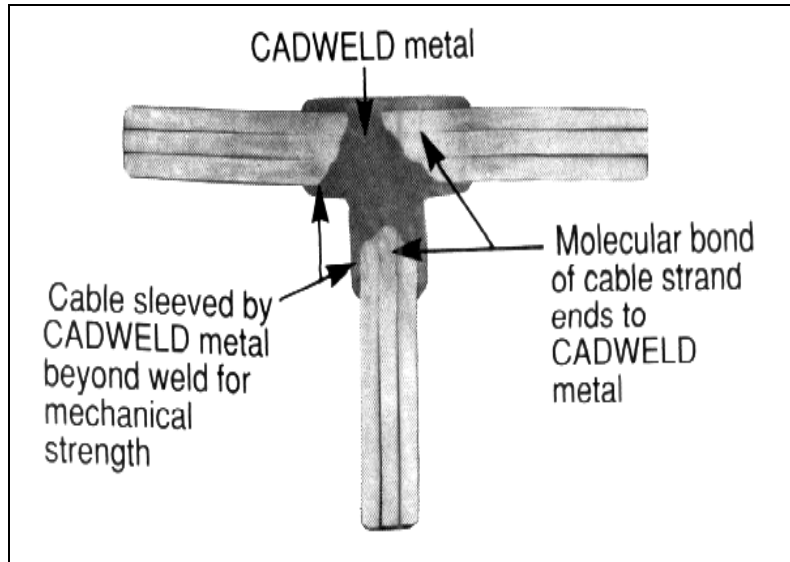
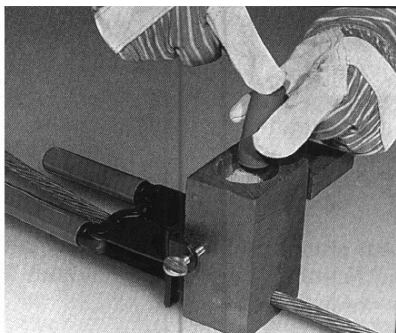
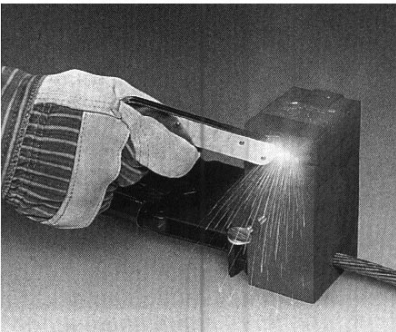

Figure B2 - Cut-A-Way Description of an Exothermic Weld.



STEP 1

Setting the mold and preparing the connection for exothermic welding.



STEP 2

Ignition of the exothermic weld compound (processing) which fuses the connection.



STEP 3

Remove the mold and inspect the new connection.

Figure B3
Procedures for Making Exothermic Welds

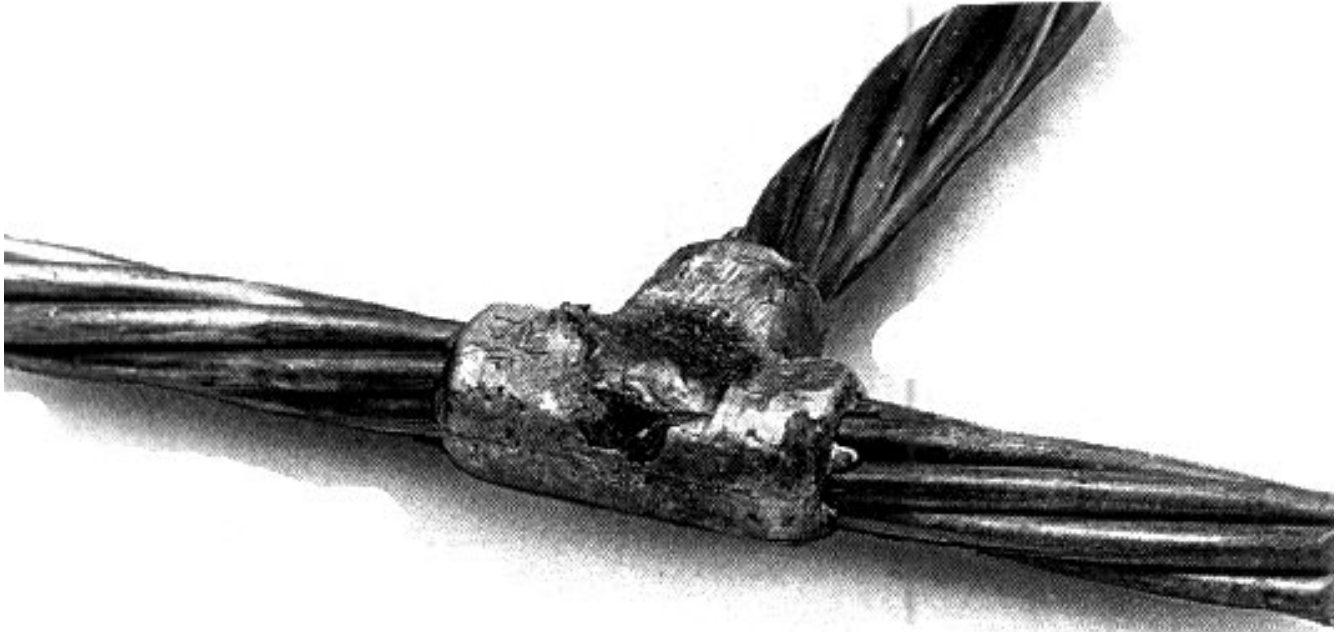

Figure B4 - ACCEPT

A clean and smooth flow of the molten (fused) metals indicates a good weld.

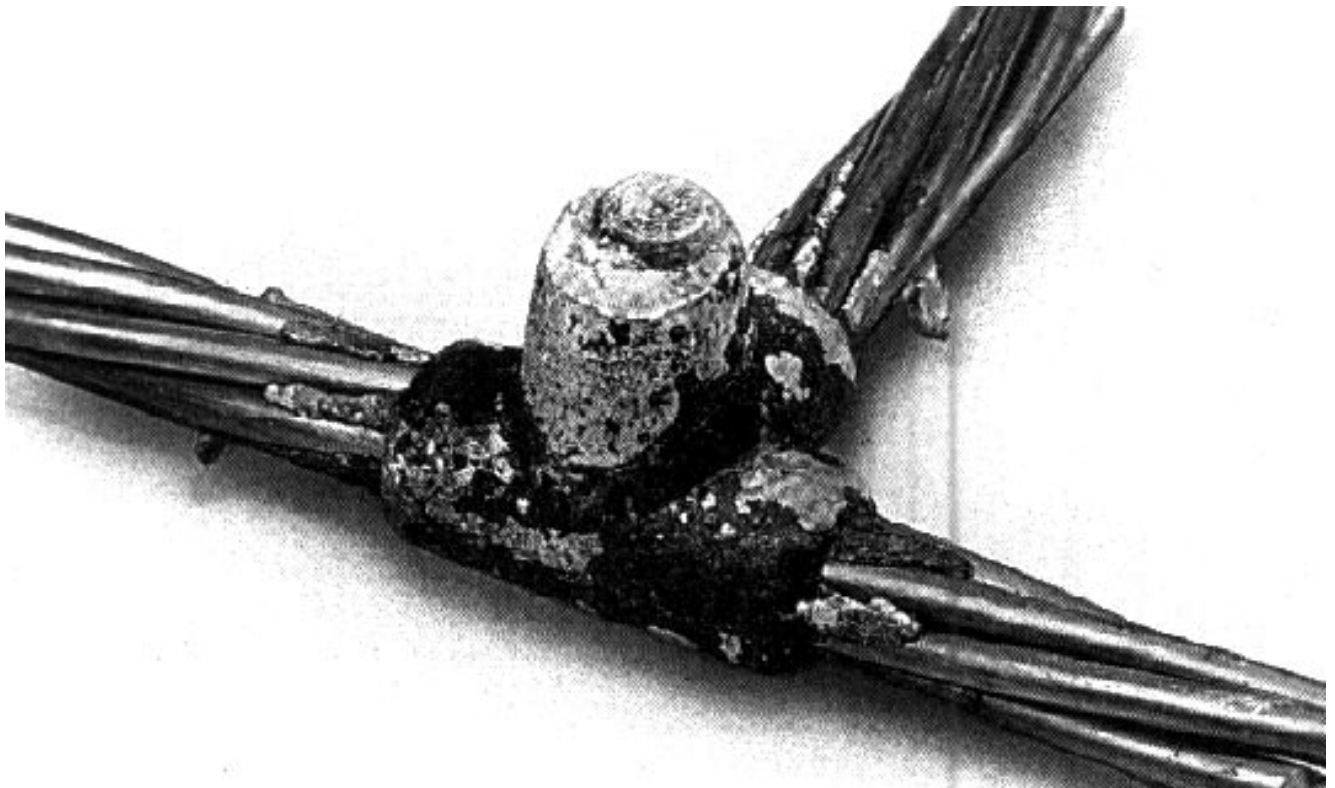

Figure B5 - REJECT

Metals not fused and with intermixed slag coating indicate a poor connection and should be rejected.

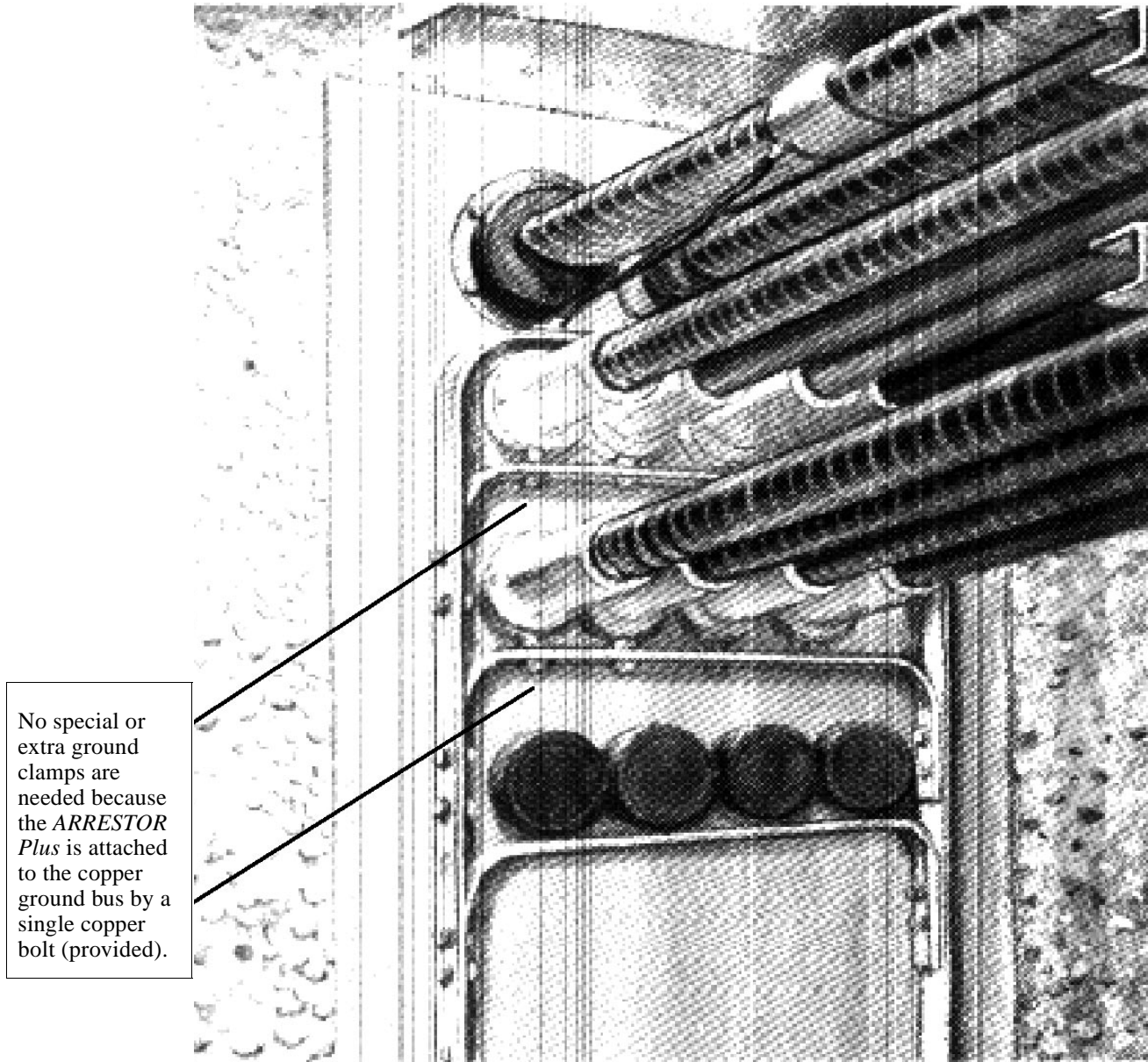

Figure B6 - Arrestor-Port-Plus Coax Bulkhead Entry

Exterior view of ARRESTORPORT Plus coax cable multiport entry bulkhead. Note the ground bolt that allows easy grounding of coax shield using only an attached threaded copper bolt.

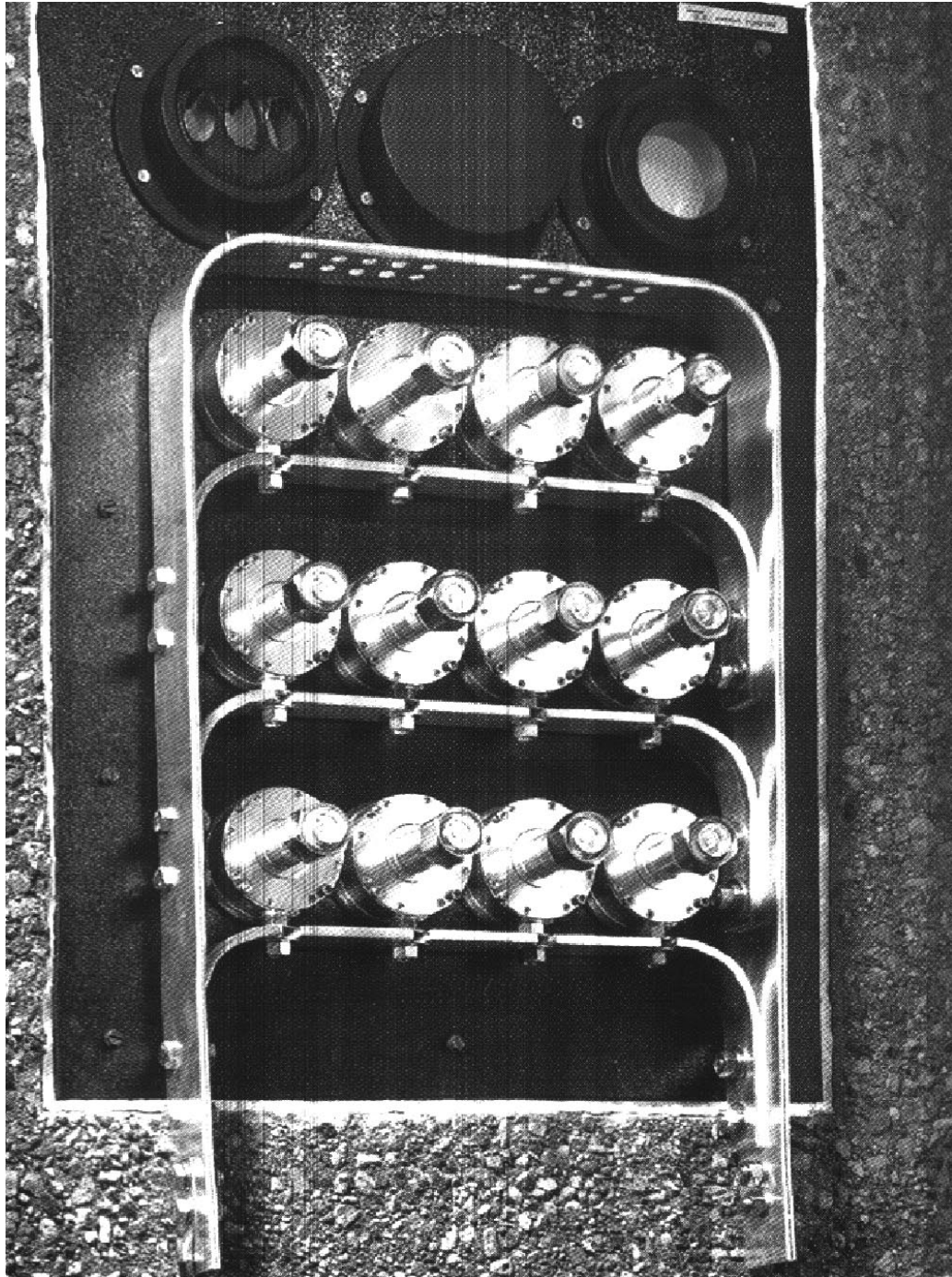

Photo Courtesy of ANDREW Corp

Figure B7 - View of Arrestor-Port-Plus Displaying “DIN” Connectors.

The ANDREW *ARRESTORPORT Plus* coax cable bulkhead entry panel as installed. This type panel allows easy access, both inside and out, to cable connectors and lightning arrestors. *Open* access assures that adding or changing a connector is not a difficult task.

Another feature of the ANDREW *ARRESTORPORT Plus* cable entry is that its presence allows it to be used as the “ground window” or ground-bar. The use of copper strap or number 4/0 stranded copper wire can be easily attached to the flat copper bars that are directly attached to the quarterwave lightning protectors. Cadweld® to the external “HALO” and/or “XIT” ground system to provide a low inductance path to ground.

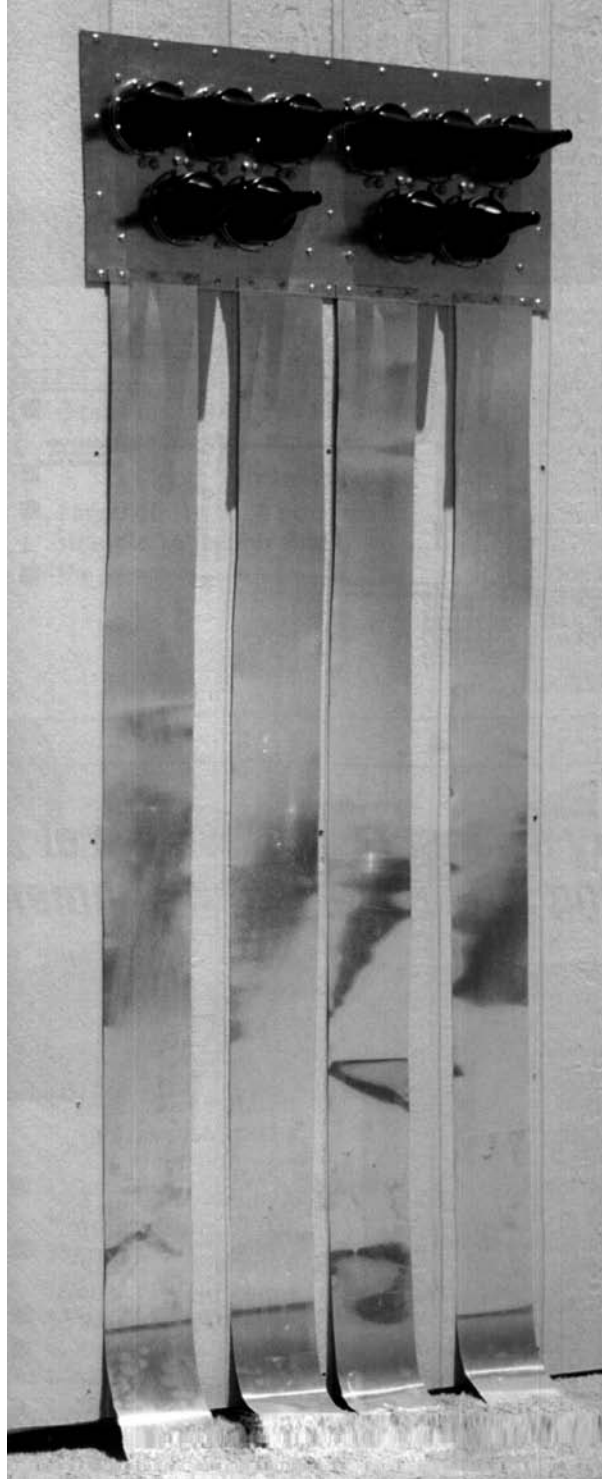

Figure B8 - Low Inductance Ground Strap Installation

Installation of “low inductance” ground straps are encouraged when and wherever possible. Note also the coax cable, multi-port bulkhead entry. Where contact is made between the copper ground straps and the bulkhead panel, *no-oxy* or copper based paste is used to prevent oxidation and to provide added conductivity (see next photo).

NOTE: Copper straps are attached to a copper bar below surface and *exothermic* welded to the “HALO” ground.

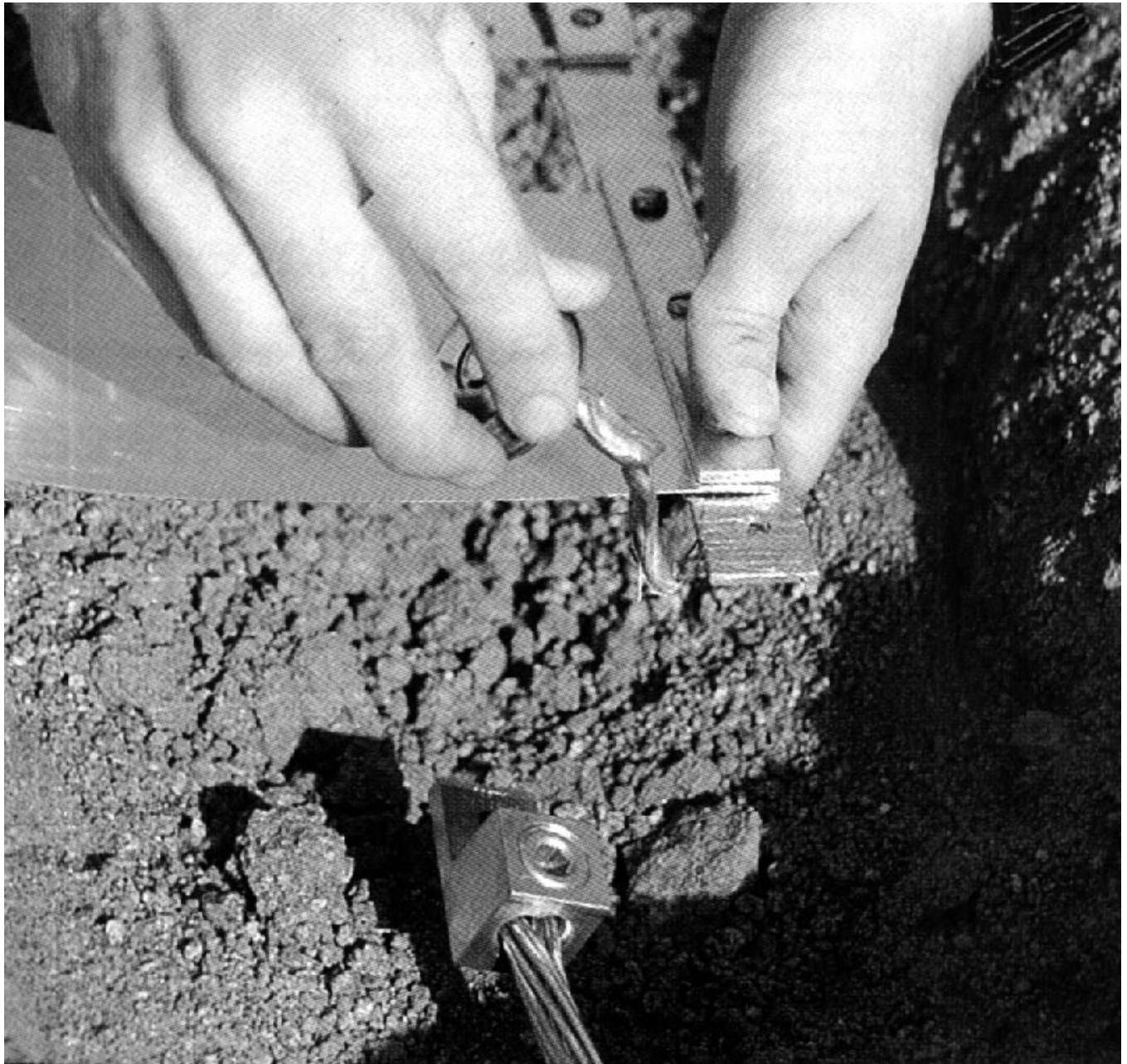

Figure B9 - Doping Ground Connections

Doping connections between low inductance copper strap and below soil copper bar. Copper bar is then exothermic welded (Cadweld®) to the ground ring (HALO). The use of no-oxy joint paste is necessary to prevent corrosion, oxidation, and surface breach due to dissimilar metal contact. This practice is strongly recommended in areas where soil acidity is high.

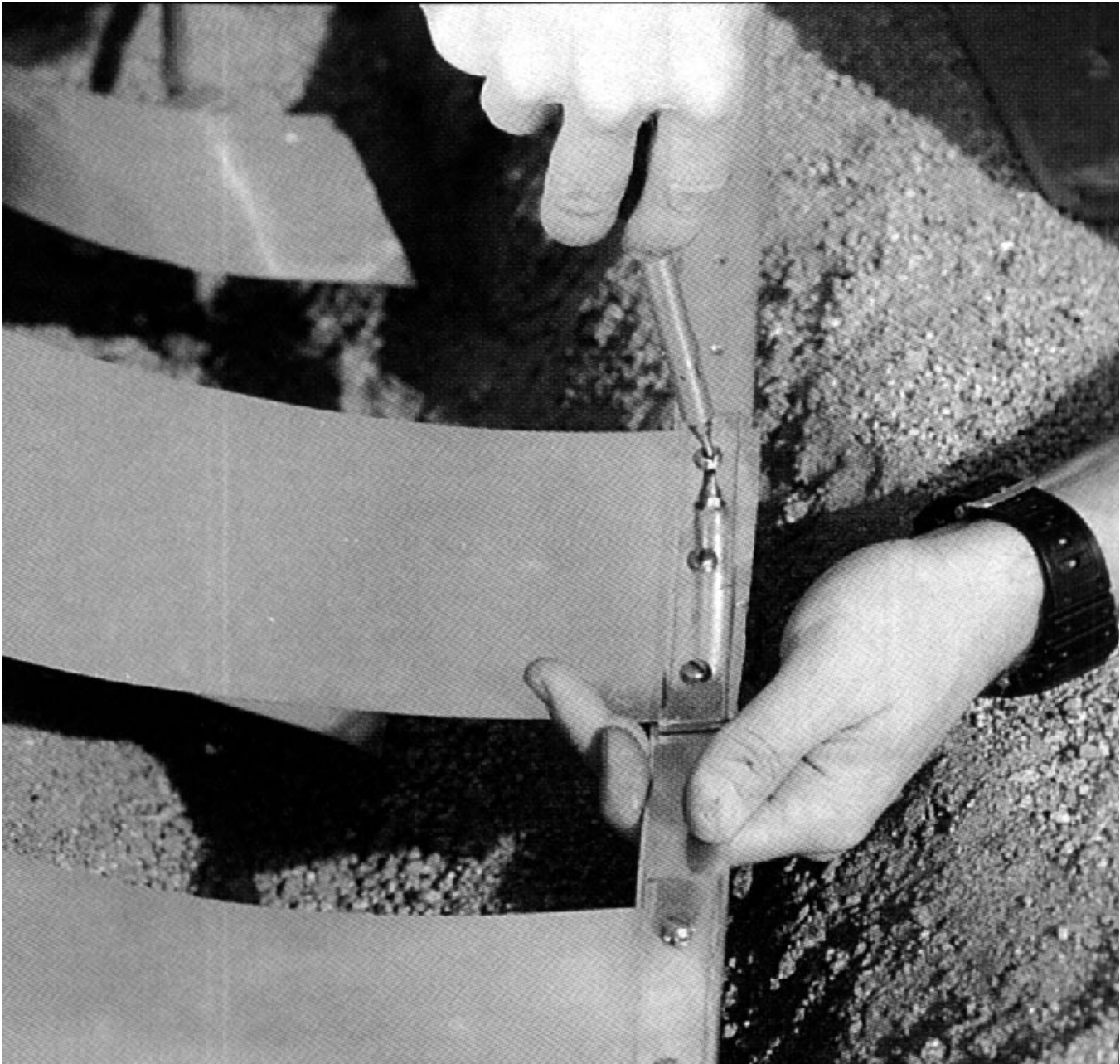

Figure B10 - Mechanical Connecting of Ground Straps

Connecting the “low-inductance” ground straps to the ground bar to be exothermic welded (Cadweld®) to the underground “HALO” ground. Include the use of No-Oxy compound between the metal components. An alternative connecting process is “silver soldering.”

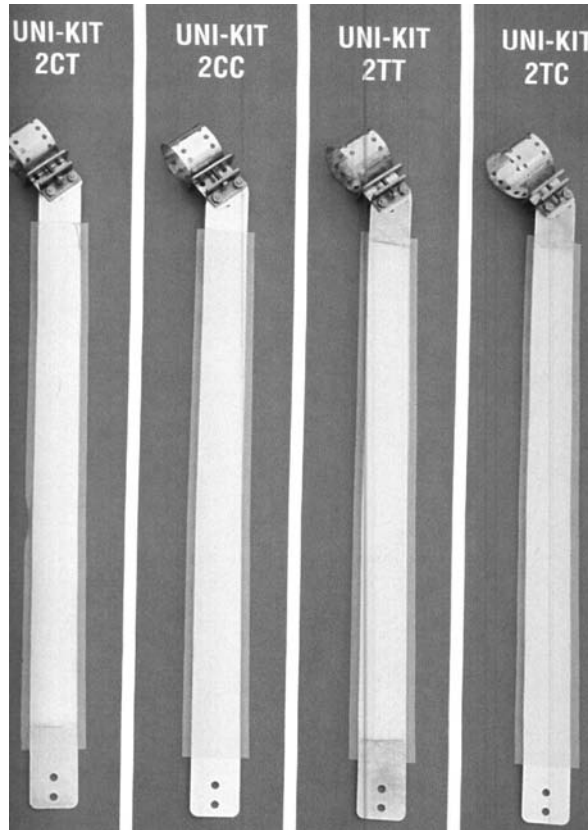

Figure B11- Universal Cable Grounding Kit

Universal cable grounding kits are employed according the metal attachments shown in the table below.

Type of metal to be <i>grounded</i> (Top clamp shown)	Grounded to (bottom end shown)	PolyPhaser Kit #
Copper or Brass	Aluminum, Tin, or Galvanized	UNI-KIT 2CT
Copper or Brass	Copper or Brass	UNI-KIT 2CC
Aluminum, Tin, or Galvanized	Aluminum, Tin, or Galvanized	UNI-KIT 2TT
Aluminum, Tin, or Galvanized	Copper or Brass	UNI-KIT 2TC

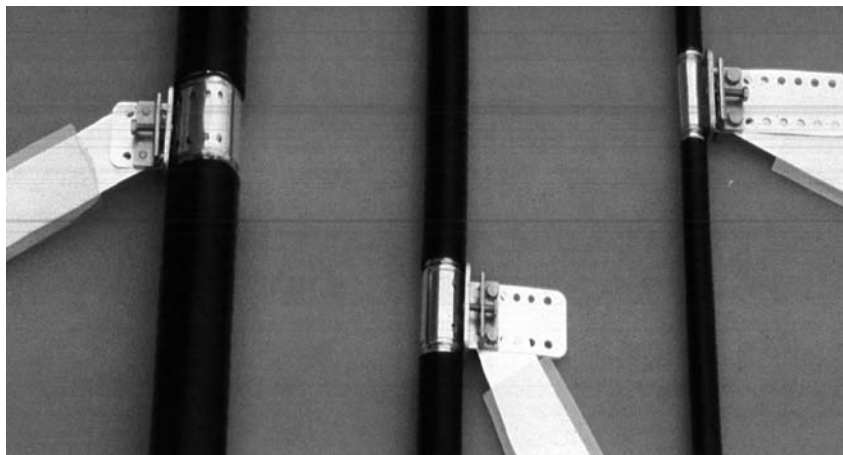

Figure B12 - UNI-Kit Typical Installations

This photo illustrates the use of the universal cable grounding kits with cables from .25 to 2 inches. These grounding kits also fit elliptical cables (hardlines) that are employed with microwave systems. See figure 13 of this document for **Andrew application and part numbers**.

Ericsson Inc.
Private Radio Systems
Mountain View Road
Lynchburg, Virginia 24502
1-800-528-7711 (Outside USA, 804-528-7711)

Printed in U.S.A.