

**MAINTENANCE MANUAL**  
**ORION™**  
**800 MHz CONTROL LOGIC/IF BOARD**  
**CMC-682/CMF-138P**

**TABLE OF CONTENTS**

	<u>Page</u>
DESCRIPTION . . . . .	Front Cover
CIRCUIT ANALYSIS . . . . .	2
Logic (CMC-682) . . . . .	2
IF (CMF-138) . . . . .	2
IC DATA . . . . .	4
PARTS LISTS:	
Logic (CMC-682) . . . . .	9
IF (CMF-138) . . . . .	11
OUTLINE DIAGRAMS:	
Logic (CMC-682) . . . . .	12
IF (CMF-138)	
SCHEMATIC DIAGRAMS:	
Logic (CMC-682) . . . . .	13
IF (CMF-138) . . . . .	15
 <b>ILLUSTRATIONS</b> 	
Figure 1 - Logic Section Block Diagram . . . . .	1
Figure 2 - IF Section Block Diagram . . . . .	1

**DESCRIPTION**

The System Control Logic/IF circuit board combines functions of receive circuit 1st IF, 2nd IF, audio detection, audio signal processing and system control on one circuit board. As an option, an additional circuit board can be plugged into this board to provide **AEGIS** (digital encryption system). Programming and personality information is stored in **FLASH** and **EEPROM** memory on the logic/IF board. The audio speaker amplifier is also part of the same board.

Electrical interfaces are achieved between this board and the Control Unit (LCC), synthesizer, RF PA (APC) and the Option and Remote Control Connector (**ORCC**) on the rear of the assembled radio.

All radio control signals originate or terminate on the control logic/IF board. Two microcomputers share the processing load. Control signals are connected through a high speed digital link with the control unit, either through the LCC or ORCC connectors, making possible either front or remote control for the radio. The same link also makes possible dual radio or dual control head configuration. An RS-232 compatible digital link is available at the ORCC interface, to facilitate programming or Radio Data Interface to Mobile Digital terminals.

This circuit board also generates Type 99, Channel Guard, GE-Star and DTMF signals if so programmed.

The System Control Logic/IF board consists of the following control logic, IF and audio circuits (see figures 1 & 2).

**Ericsson Inc.**  
 Private Radio Systems  
 Mountain View Road  
 Lynchburg, Virginia 24502  
 1-800-528-7711 (Outside USA, 804-528-7711)

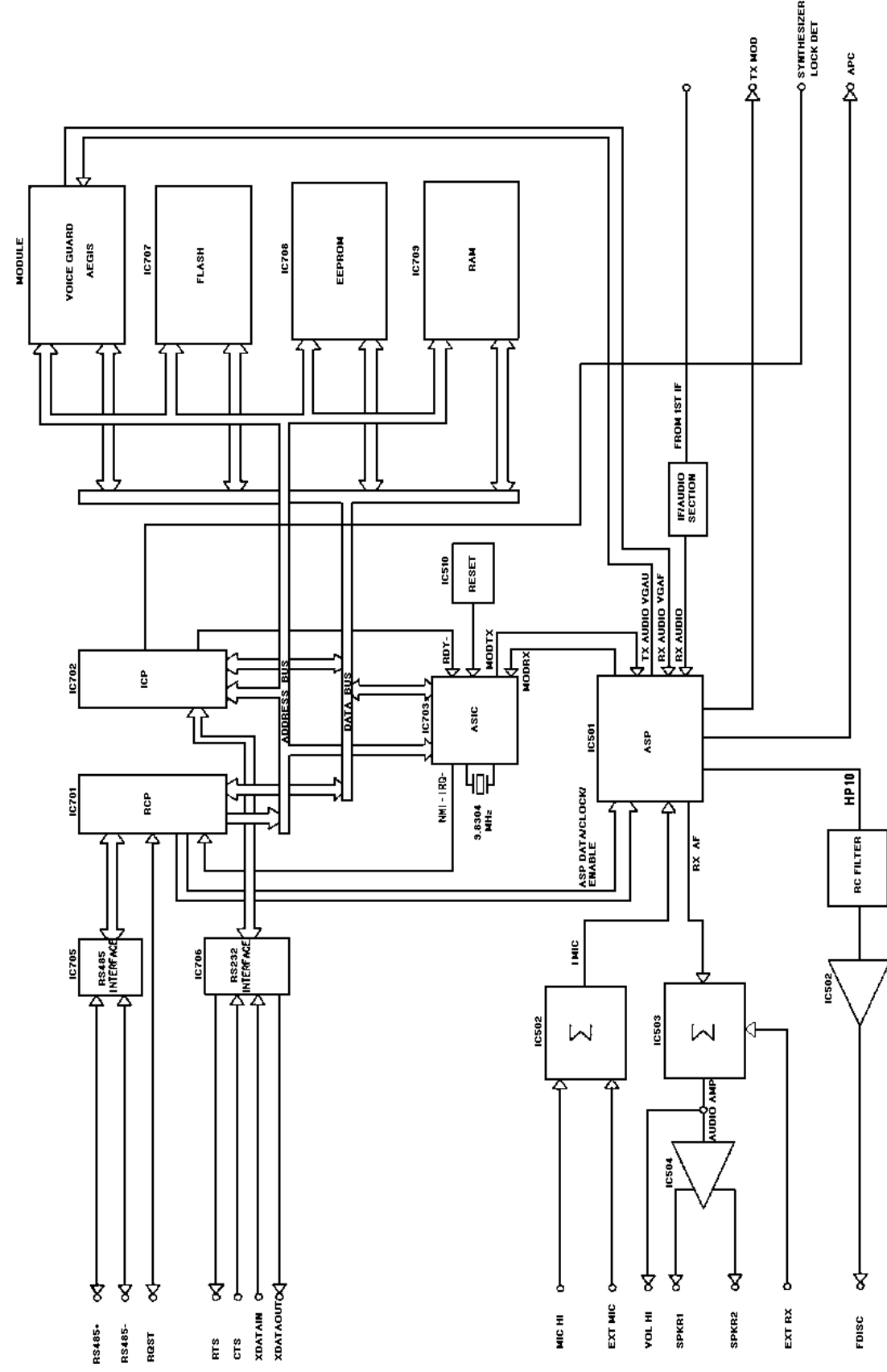

Figure 1 - Logic Section Block Diagram

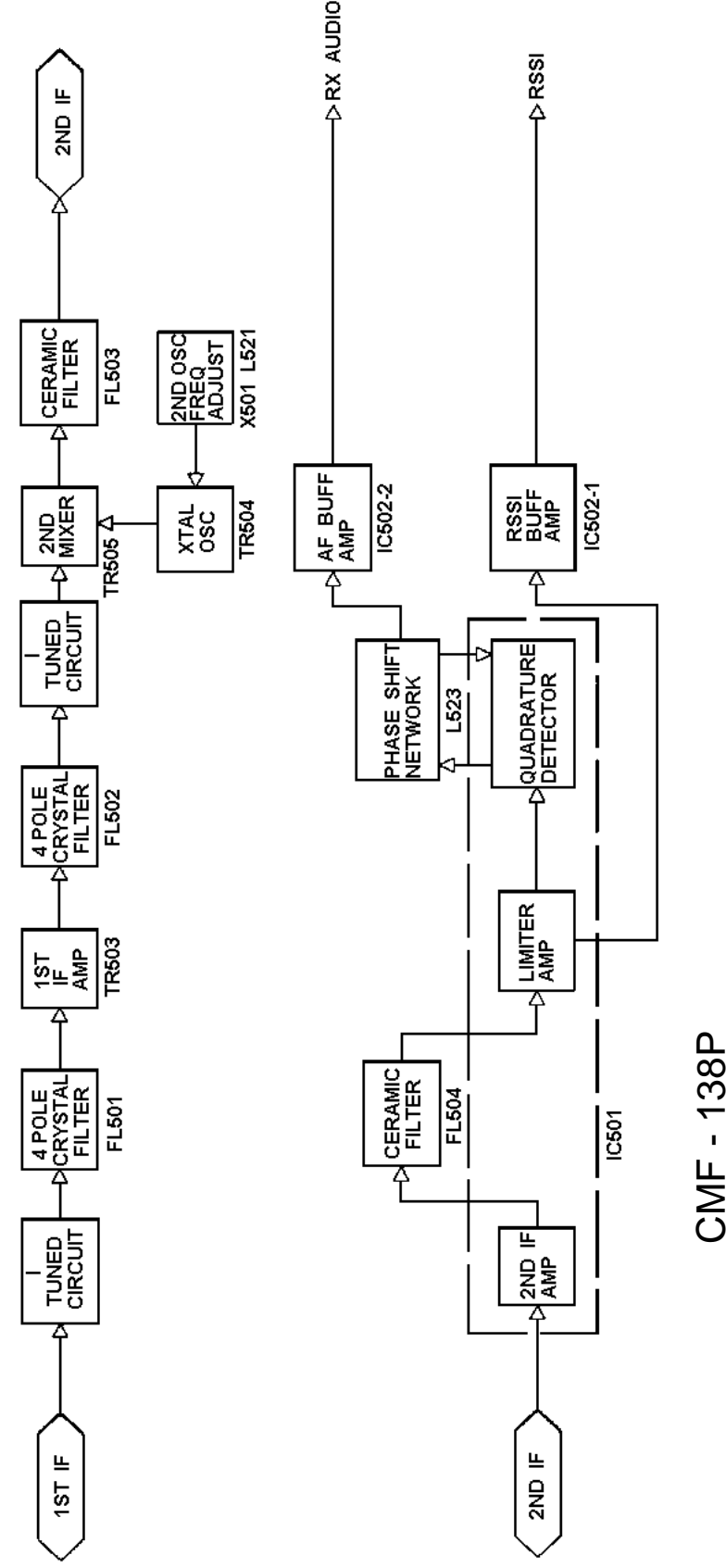

Figure 2 - IF Section Block Diagram

**SYSTEM CONTROL LOGIC (CMC-682)**

- CMOS Microprocessor (IC701, IC702)
- Custom CMOS ASIC Chip (IC703)
- Address Decoder (IC704)
- RS-485 (IC705)
- RS-232 (IC706)
- Flash EEPROM (IC707)
- EEPROM (IC708)
- CMOS SRAM (IC709)
- CMOS Inverters (IC711)
- Silicon Serial Number (IC712)
- TTL Inverters (IC713)

**IF (CMF-138)**

- Custom CMOS ASP Chip (IC601)
- Operational Amplifier (IC602, IC603)
- Audio Amplifier (IC604)
- 5 Volt Regulator (IC606, IC607)
- 9 Volt Regulator (IC605, IC608, IC609)
- Reset Circuit (IC610)
- Bilateral Switch (IC611, IC612)

**CIRCUIT ANALYSIS**

**LOGIC SECTION (CMC-682)**

Microcomputer

The main microcomputer circuit in the **ORION** radio consist of microprocessor IC701, EEPROM IC708, Flash EEPROM IC707, RAM IC709 and custom ASIC IC703. This circuitry runs at a 9.8304 MHz rate determined by crystal X701 and controls the radio through a second microprocessor IC702. This second microprocessor runs at a 4.9152 MHz rate. The 4.9152 MHz rate is determined by ASIC IC703.

- Controlling the **ASIC, FLASH EEPROM and RAM**

- Loading data to the frequency synthesizer
- Fetching and processing the PTT, monitor, channel, selection and volume control
- Controlling the audio circuit (processor)
- Decoding the squelch
- Encoding/Decoding the Channel Guard and Digital Channel Guard
- Controlling the loading interface for the radio data (channel number and signaling)

**FLASH EEPROM (IC707)**

This memory contains the software to control the microprocessor. This Flash EEPROM has a storage capacity of 256k x 8 bits.

**CMOS SRAM (IC709)**

This SCRATCH RAM has a storage capacity of 32k x 8 bits. The memory is available for variables, buffers, etc.

**EEPROM (IC708)**

This EEPROM has a storage capacity of 8k x 8 bits. The memory contains the user configurable parameters that must be maintained through a power cycle. This personality controls various functions of the radio. The personality data is entered from outside the radio through the ORCC connector to the microprocessor and then to the EEPROM. The data mainly consists of the following:

- Channel Frequency Data
- CG/DCG Data
- Tx Power, Tx Modulation Data
- Squelch Data
- Display Data, etc.

**APPLICATION OF SPECIFIC INTEGRATED CIRCUITS**

**ASIC (IC703)**

The ASIC is basically a chip that integrates many miscellaneous functions. The chip provides functions as follows:

- MODEM
- Watch Dog Timer
- Clock Control

- Interrupt Control
- Address Decode etc.

**Voltage Regulators (IC606, IC607) (IC605, IC608, IC609)**

Voltage regulators IC606 and IC607 each generate a 5 Vdc for the Control Board. Voltage regulators IC605, IC608 and IC609 each generate a 9 Vdc for the Control Board and Voice Guard Adapter Module.

**Audio Amplifier (IC604)**

The audio amplifier is located between the audio processor and the speaker. Amplifier IC604 amplifies the output signal of the ASP (IC601) to the level adequate for driving the speaker.

**Audio Signal Processor (ASP) (IC601)**

The audio processor consists of a one-chip IC accommodating almost all of the audio functions. The audio functions are under control of the microcomputer in compliance with the function of the radio unit. The functions of the audio processor are as follows:

- Rx Audio Processor with Tone Reject Filter, De-emphasis and Programmable Attenuator.
- Data Limiting
- CG/DCG filtering and limiting
- Noise Squelch filtering and detecting
- 8 bits D/A Converter with sample and hold
- Tx Audio Processor with microphone amplifier, pre-emphasis, deviation limiter, summing amplifier,
- post limiter filter and programmable attenuator
- Data signal filtering
- Two 6 bits programmable divider for clock and alert tone

All of these functions are made up of switched capacitor filters, amplifiers and timing logic. The timing for this logic is derive from the 4.9152 MHz clock generator (ASIC).

**RS-485 (IC705)**

This is a high speed differential TRI-STATE bus/line transceiver designed to meet the requirements of EIA standard RS-485 specification. The IC705 is located between the Radio Unit and the Control Unit.

**RS-232 (IC706)**

This IC consists of line drivers/receivers designed to meet the requirements of EIA standard RS -232 specifications. The IC706 is located between the radio unit and the ORCC to drive external data terminal devices.

**Reset Circuit (IC610)**

This is an active low reset IC which includes a delay time generating circuit. Delay time can be set up by externally using a capacitor and a resistor. The function of this IC is to accurately reset the system after detecting voltage at the time of switching power on and instantaneous power off.

**Option and Remote Control Connector (ORCC)**

The ORCC is located on the rear of the radio and is used for options and accessories when Control Unit and Radio Unit are directly attached and for remote control in all other configurations. The ORCC allows various kinds of external equipment connections to be made. External equipment connecting signals are as follows:

PIN	SIGNAL	PIN	SIGNAL
1	SUP GND	20	RTS
2	XDATA IN	21	INP1
3	XDATA OUT	22	OUT1
4	RS485+	23	INP2
5	RS485-	24	IGN A+
6	CTS	25	SW +
7	GND	26	HKSW
8	FPROG	27	EXTMIC
9	OUT2	28	EXTRX
10	IGN SEN	29	FDISC
11	MIC HI	30	EXTALO
12	ALO	31	CUTST
13	VOL HI	32	SPARE
14	CTL ON	33	SPARE
15	XTONENC	34	SPARE
16	XTONEDEC	35	SDATA
17	RQST	36	SONOFF
18	SPKR1	37	HORNRING
19	SPKR2		

**IF SECTION (CMF-138)****1st IF**

The 82.2 MHz 1st IF output signal is coupled from the output of the first mixer circuit, located on the Synthesizer/Receiver/IF board, through 30-pin connector P501-1 and capacitor C501 to the source input of buffer amplifier Junction Field Effect Transistors (JFET) TR501 and TR502. This input can be monitored at test point TP1. The output of TR501 and TR502 is coupled through inductor L502 to 4-pole crystal band-pass filter FL501. The highly-selective crystal filters FL501-1 and FL502-2 provide the first part of receiver IF selectivity. The output of the filters is coupled through the impedance matching network consisting of inductor L502 and capacitors C504 and C505 to the base of 1st IF amplifier transistor TR503. The crystal filter output of FL501 is applied to the base of 1st IF amplifier transistor TR503. This amplified signal is taken from the collector of TR503 through an impedance matching network consisting inductor L505, capacitor C506 and resistor R507 that matches the amplifier output to the input of 4-pole crystal filters FL502-1 and FL502-2 which provides the second part of receiver IF selectivity. The output of the crystal filters is coupled through an impedance-matching network consisting of inductor L507, capacitor C508, resistor R508 and coupling capacitor C509 to the base of 2nd IF amplifier transistor TR505.

**2nd Mixer**

The 82.2 MHz IF input is applied to transistor TR505 and mixed with a 82.655 MHz frequency supplied by a crystal oscillator circuit consisting of X501 and oscillator transistor TR504. Variable inductor L521 sets the frequency of the oscillator circuit. This signal can be monitored at test point TP5.

**2nd IF And Detector**

The output of the 2nd mixer is coupled to the input of 4-pole ceramic filter FL503 which provides 455 kHz 2nd IF selectivity. The 455 kHz IF output of ceramic filter FL503 is coupled to Pin 3 of Limiter/FM Detector IC501. The IF signal is amplified internal to IC501 then applied to 4-pole ceramic filter FL504 which provides additional 455 kHz IF selectivity (Refer to **IC DATA** for IC501). The output of the 455 kHz filter is applied to IC501, Pin 7. The 2nd IF signal is amplified and limited internal to IC501. Inductor L523 shifts the IF signal by 90° and applies it to the internal FM detector. The FM detector compares the shifted IF signal to the internal IF signal to recover the audio modulation. The audio output of the operational amplifier internal to IC501 is applied the input of buffer amplifier IC502-2. The **AUDIO** output of IC502-2 is applied to the System Control Logic circuit. This signal can be monitored at test point TP4. The output on Pin 12 of IC501 is applied to the input of amplifier buffer IC502-1. The output of

IC502-1 provides a Receiver Signal Strength Indicator (RSSI) signal also sent to the System Control Logic circuit. This signal can be monitored at test point TP3.

**9 Volt Regulator**

The 9-volt regulator circuit powers the IF circuits of CMF-138 and consists of regulator IC503 and filter capacitors C570, C571 C572 and C573. An input voltage of +13.8 Vdc is applied to the input of IC503 This input is monitored at test point TP2.

Linear, IF Amplifier/Detector IC501

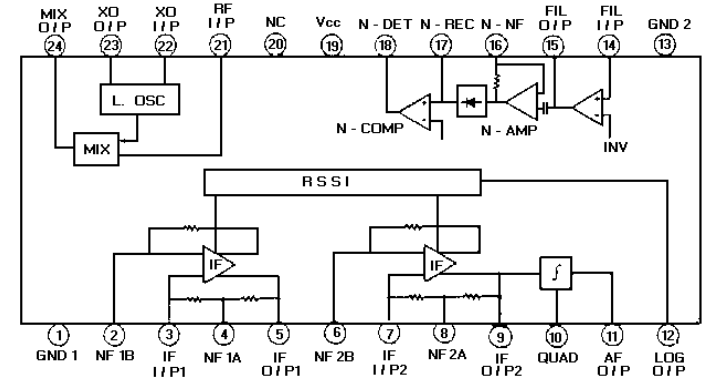
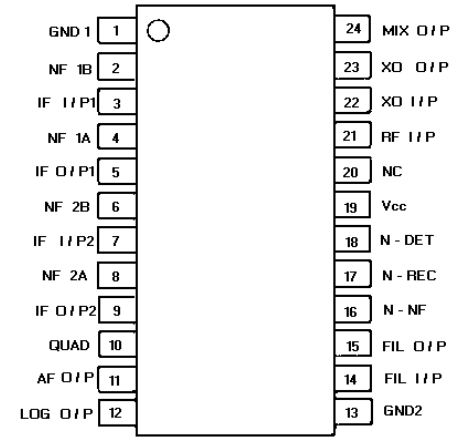

Linear, Positive Voltage Regulator IC503

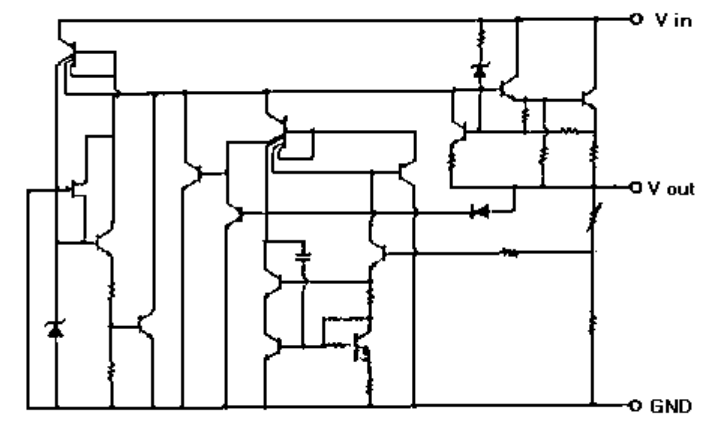
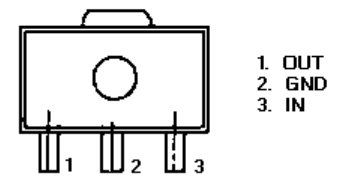

Linear, Dual Operational Amplifier IC502

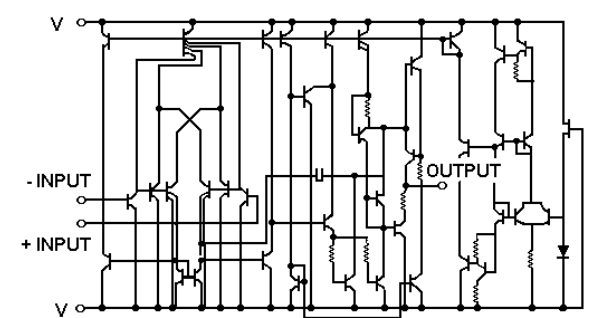
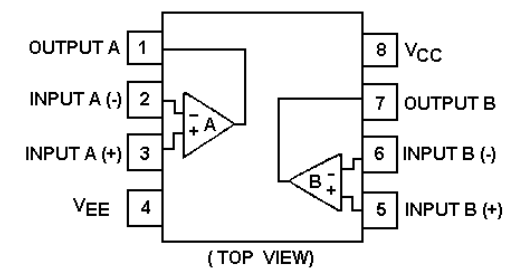

Audio Signal Processor IC601

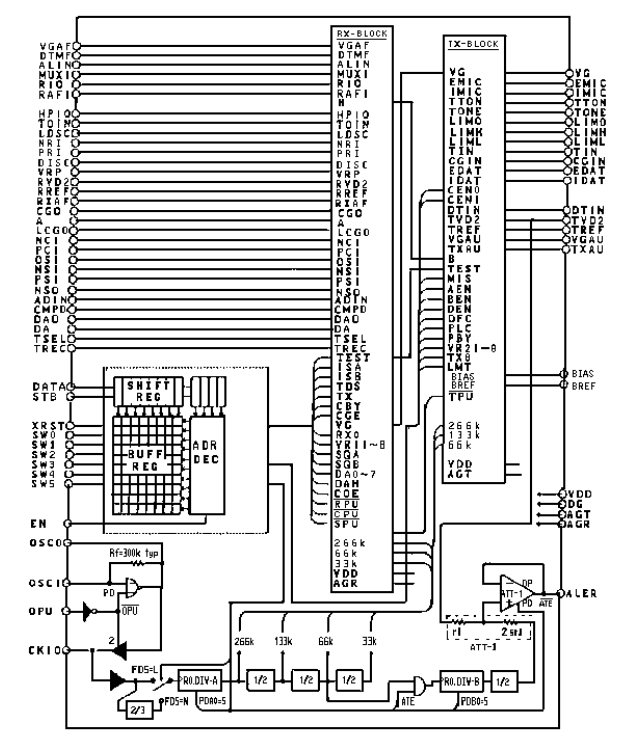
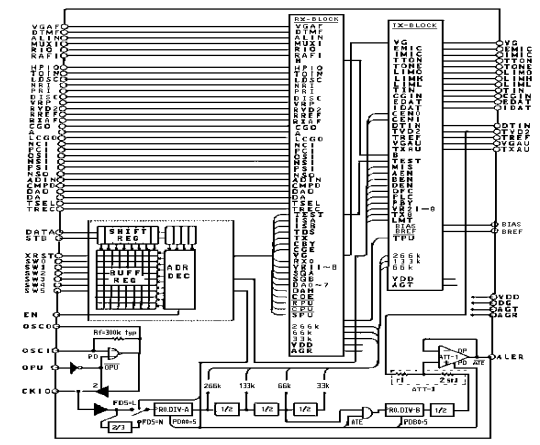

Linear Audio Amplifier IC602, IC603

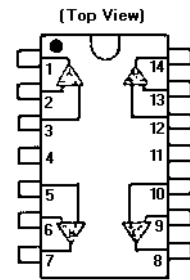

- 1. A OUTPUT
- 2. A - INPUT
- 3. A + INPUT
- 4. V+
- 5. B+ INPUT
- 6. B- INPUT
- 7. B OUTPUT
- 8. C OUTPUT
- 9. C- INPUT
- 10. C+ INPUT
- 11. V-
- 12. D+ INPUT
- 13. D- INPUT
- 14. D OUTPUT

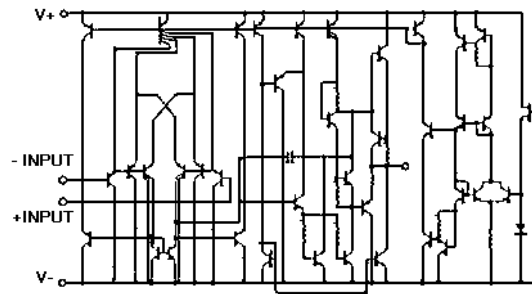

Linear: Positive Voltage Regulator IC606

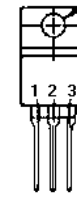

- PIN 1. INPUT
- 2. GROUND
- 3. OUTPUT

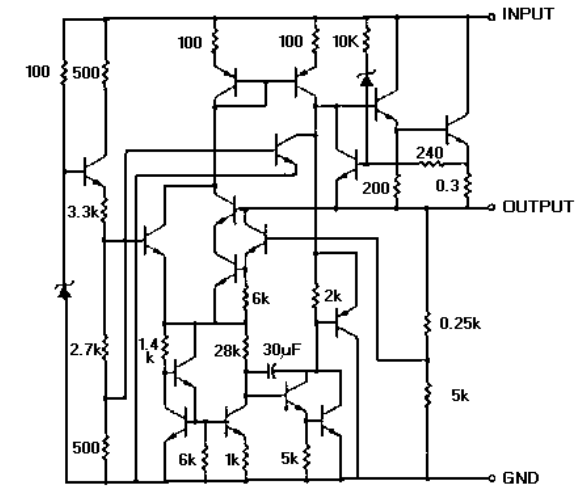

Audio Frequency Power Amplifier IC604

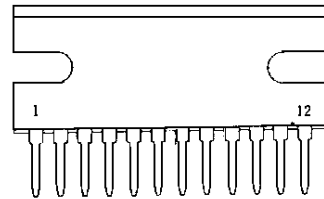

- 1. INPUT
- 2. NFB 1
- 3. GND (INPUT)
- 4. NFB 2
- 5. FILTER
- 6. VCC
- 7. STAND-BY SW
- 8. BOOTSTRAP 2
- 9. OUTPUT 2
- 10. GND (OUTPUT)
- 11. OUTPUT 1
- 12. BOOTSTRAP 1

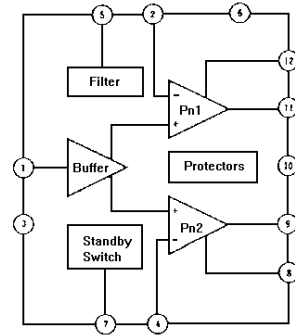

Linear: Positive Voltage Regulator IC607

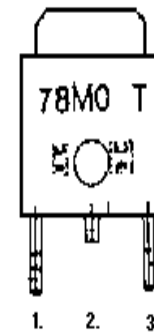

- 1. INPUT
- 2. GND
- 3. OUTPUT

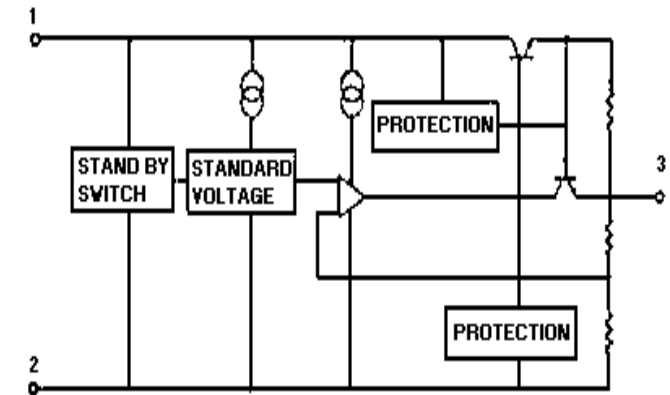

Linear: Positive Voltage Regulator IC605, IC609

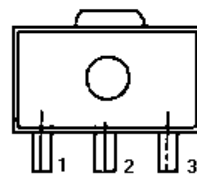

- 1. OUT
- 2. GND
- 3. IN

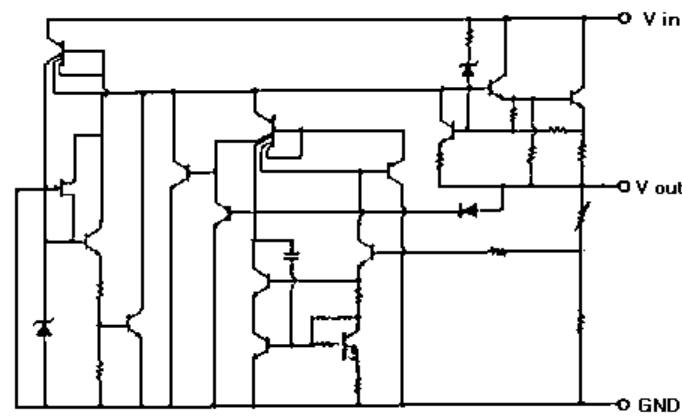

Linear: Positive Voltage Regulator IC608

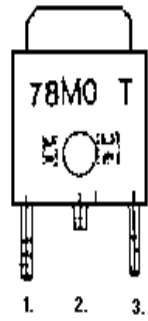

- 1. INPUT
- 2. GND
- 3. OUTPUT

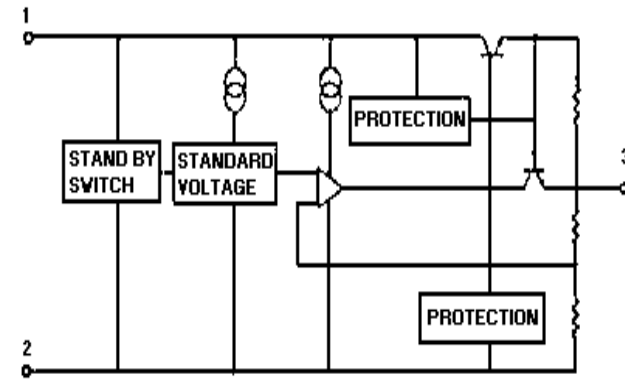

Bilateral Switch IC611, IC612

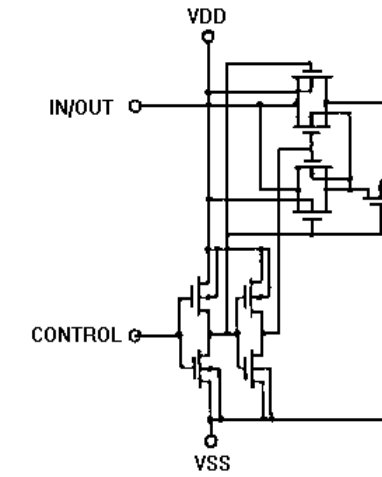
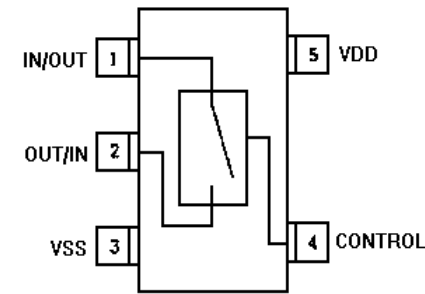

Reset Circuit IC610

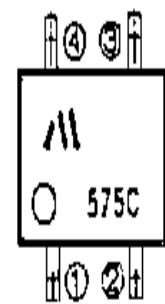

- 1. VCC
- 2. OUT
- 3. Cd
- 4. GND

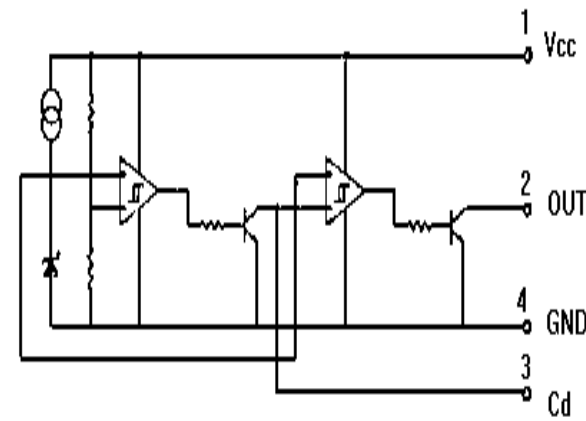

Central Processing Unit IC701

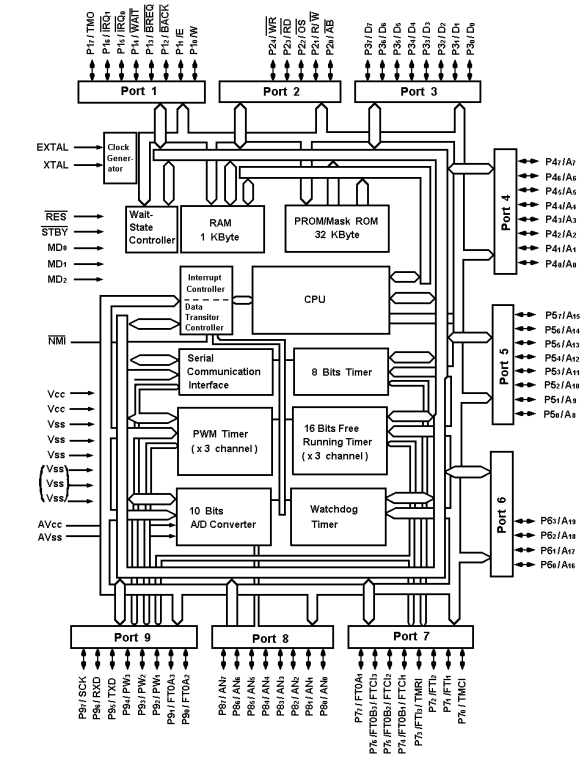
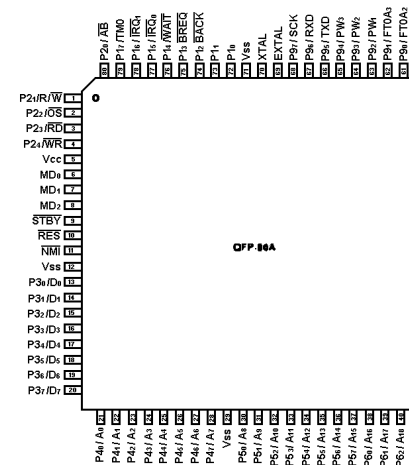

Central Processing Unit IC702

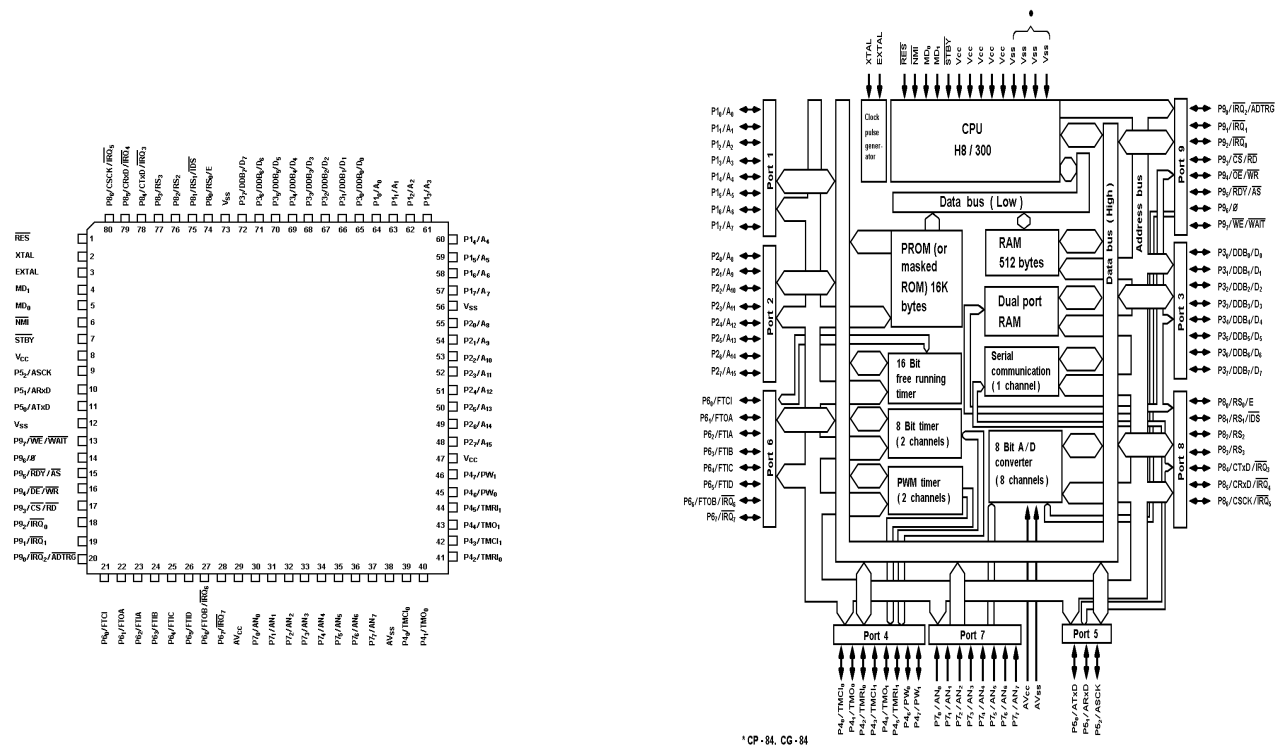

Decoder IC704

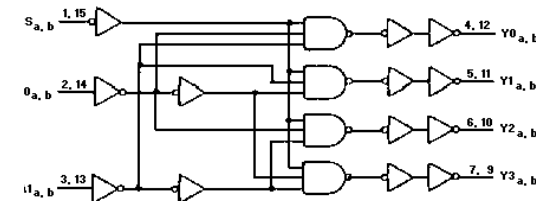
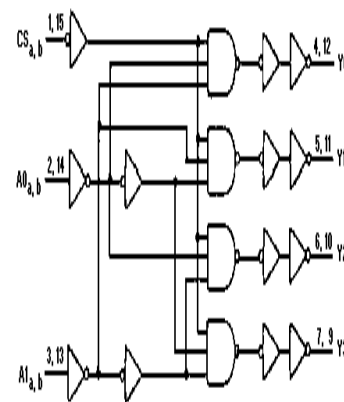

ASIC IC703

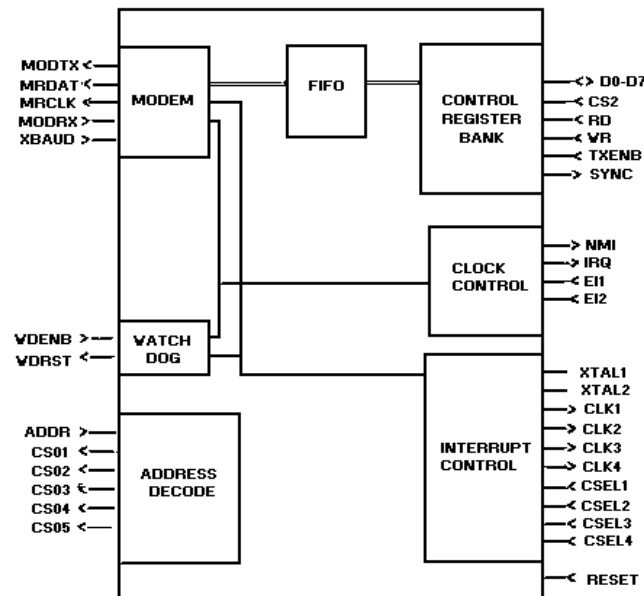
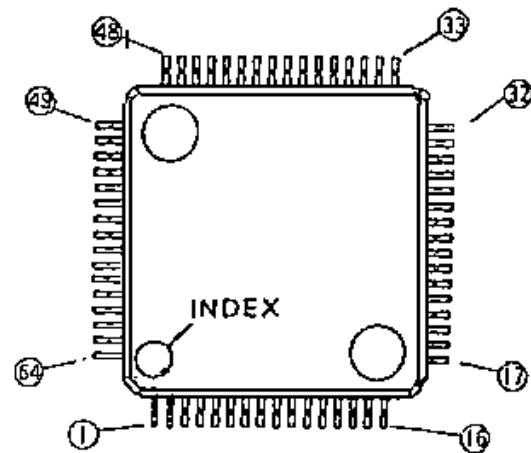

RS-485 Driver/Receiver IC705

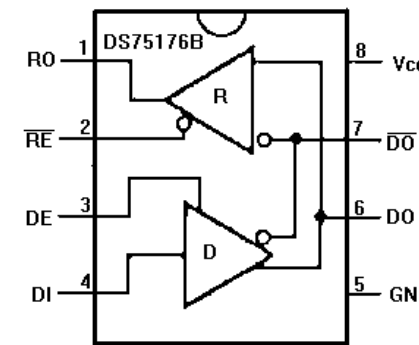
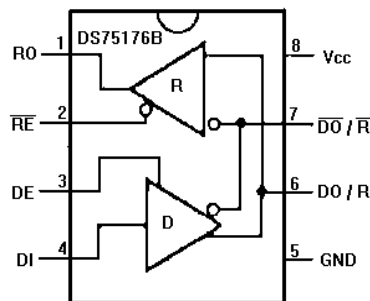



RS-232 Driver/Receiver IC706

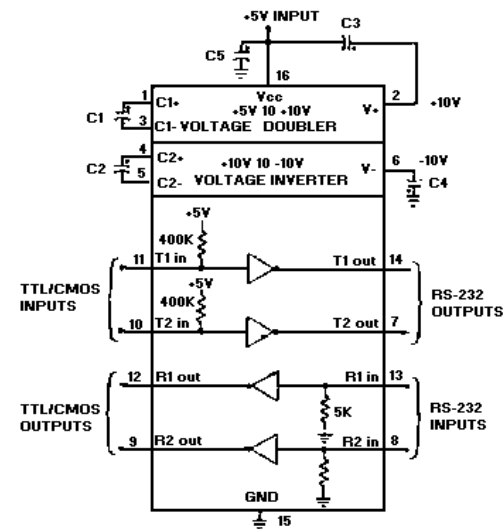
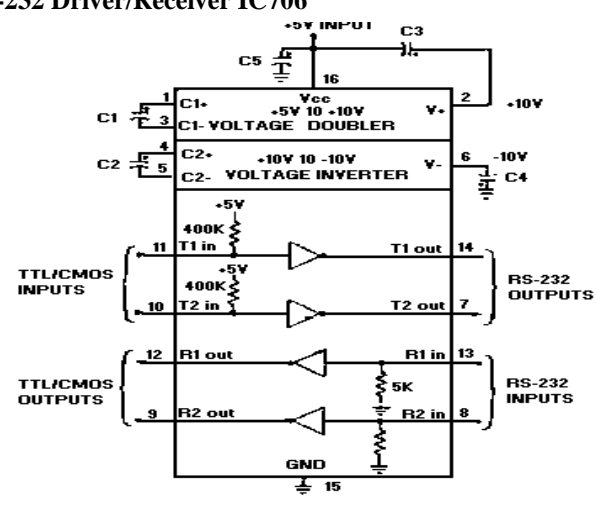

EEPROM IC708

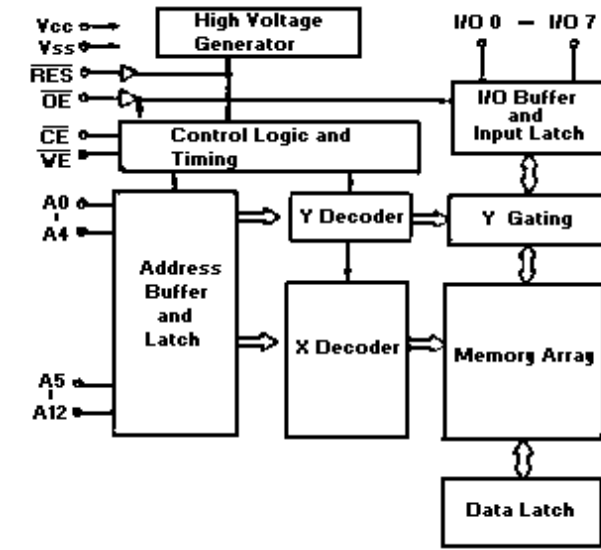
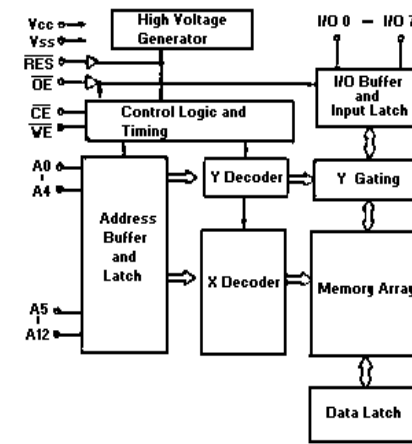

Flash Memory IC707

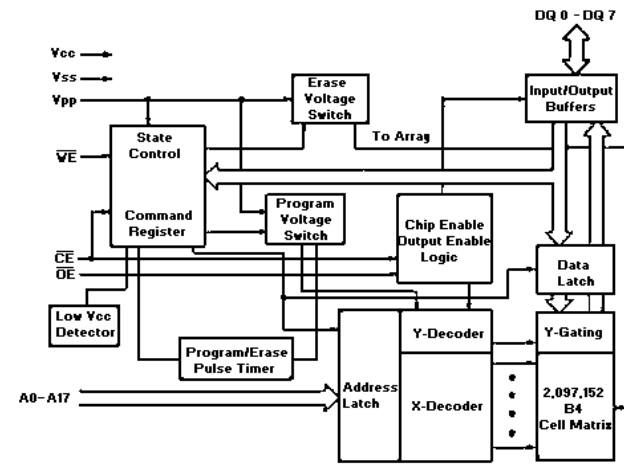
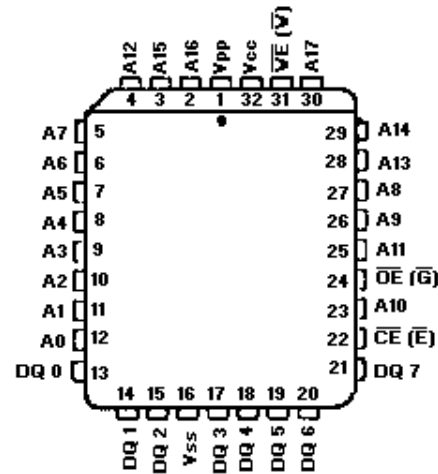

RAM IC709

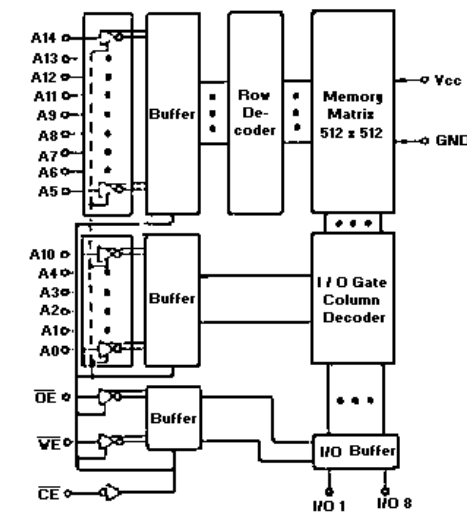
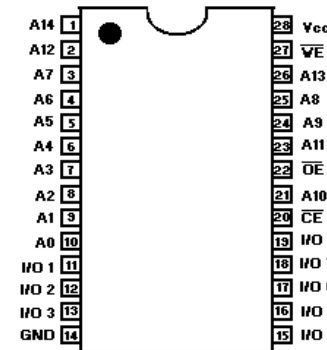

Inverter IC711

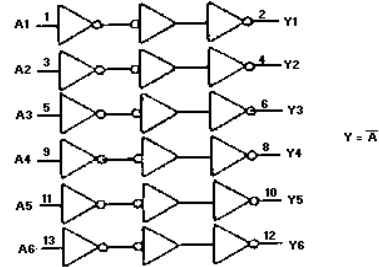
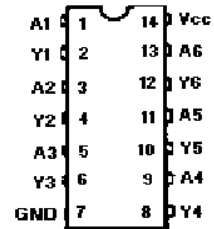

Silicon Serial Number IC712

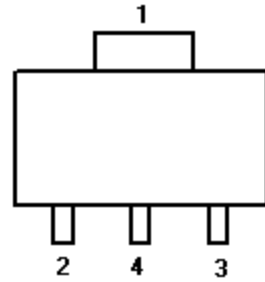

- 1. GND
- 2. DATA (DG)
- 3. NC
- 4. GND

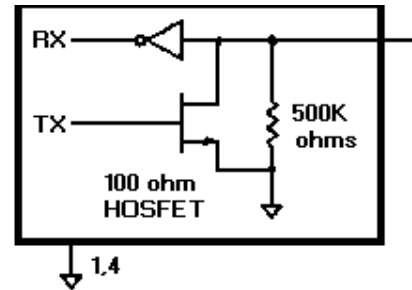

Inverter IC713

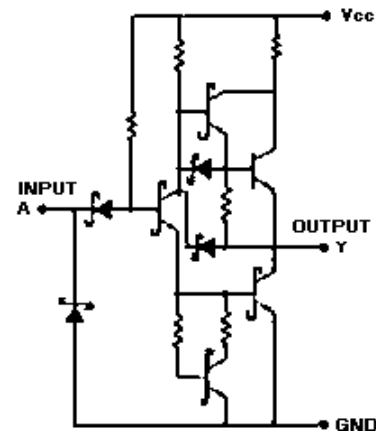
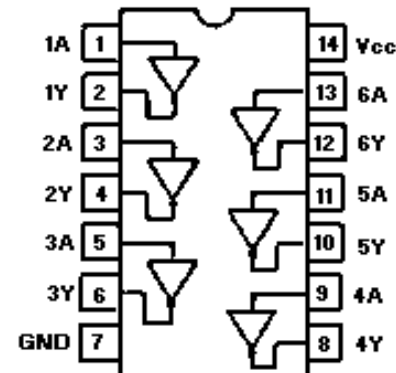

SYSTEM CONTROL LOGIC/IF/AUDIO BOARD

LOGIC SECTION  
CMC-682

SYMBOL	PART NO.	DESCRIPTION
----- CAPACITORS -----		
C601	NOTE: Parts listed are for reference only. Refer to Service Section for serviceable parts.	Ceramic: 0.01 $\mu$ F $\pm$ 10% 50 VDCW, temp coef $\pm$ 15%.
C602		Ceramic: 1 $\mu$ F $\pm$ 5% 16 VDCW, temp coef $\pm$ 22%/-82%.
C603		Ceramic: 220 pF $\pm$ 5% 50 VDCW, temp coef 0 $\pm$ 30 PPM/ $^{\circ}$ C.
C604		Ceramic: 0.1 $\mu$ F $\pm$ 20% 25 VDCW.
C605		Ceramic: 0.01 $\mu$ F $\pm$ 10% 50 VDC, temp coef $\pm$ 15%.
C606		Tantalum: 1 $\mu$ F $\pm$ 20% 16 VDCW.
C607 thru C609		Ceramic: 0.1 $\mu$ F $\pm$ 20% 25 VDCW, temp coef $\pm$ 22%/-82%.
C610		Tantalum: 1 $\mu$ F $\pm$ 20% 16 VDCW.
C611		Ceramic: 0.1 $\mu$ F $\pm$ 20% 25 VDCW, temp coef $\pm$ 22%/-82%.
C612		Tantalum: 3.3 $\mu$ F $\pm$ 20% 16 VDCW.
C613		Tantalum: 1 $\mu$ F $\pm$ 20% 16 VDCW.
C614		Tantalum: 0.33 $\mu$ F $\pm$ 20% 35 VDCW.
C615		Ceramic: 100 pF $\pm$ 5% 50 VDCW, temp coef 0 $\pm$ 30 PPM/ $^{\circ}$ C.
C616		Ceramic: 1 $\mu$ F $\pm$ 20% 16 VDCW, temp coef $\pm$ 22%/-82%.
C617		Tantalum: 0.33 $\mu$ F $\pm$ 20% 35 VDCW.
C618		Ceramic: 0.1 $\mu$ F $\pm$ 20% 25 VDCW, temp coef $\pm$ 22%/-82%.
C621 and C622		Ceramic: 0.1 $\mu$ F $\pm$ 20% 25 VDCW, temp coef $\pm$ 22%/-82%.
C623		Tantalum: 22 $\mu$ F $\pm$ 20% 16 VDCW.
C624		Ceramic: 0.1 $\mu$ F $\pm$ 20% 25 VDCW, temp coef $\pm$ 22%/-82%.
C625		Tantalum: 1 $\mu$ F $\pm$ 20% 16 VDCW.
C626		Ceramic: 0.1 $\mu$ F $\pm$ 20% 25 VDCW, temp coef $\pm$ 22%/-82%.
C627		Tantalum: 22 $\mu$ F $\pm$ 20% 16 VDCW.
C628 and C629		Ceramic: 0.1 $\mu$ F $\pm$ 20% 25 VDCW, temp coef $\pm$ 22%/-82%.
C630		Tantalum: 22 $\mu$ F $\pm$ 20% 16 VDCW.
C631 and C632		Ceramic: 0.1 $\mu$ F $\pm$ 20% 25 VDCW, temp coef $\pm$ 22%/-82%.
C633		Tantalum: 22 $\mu$ F $\pm$ 20% 16 VDCW.
C634 thru C637		Ceramic: 0.1 $\mu$ F $\pm$ 20% 25 VDCW, temp coef $\pm$ 22%/-82%.
C638		Ceramic: 220 pF $\pm$ 5% 50 VDCW, temp coef 0 $\pm$ 30 PPM/ $^{\circ}$ C.
C639		Electrolytic: 47 $\mu$ F $\pm$ 20% 25 VDCW.
C640		Ceramic: 0.1 $\mu$ F $\pm$ 20% 25 VDCW, temp coef $\pm$ 22%/-82%.
C641 and C642		Electrolytic: 22 $\mu$ F $\pm$ 20% 16 VDCW.
C643		Ceramic: 0.1 $\mu$ F $\pm$ 20% 25 VDCW, temp coef $\pm$ 22%/-82%.
C644		Electrolytic: 10 $\mu$ F $\pm$ 20% 25 VDCW.
C645		Ceramic: 1 $\mu$ F $\pm$ 20% 25 VDCW, temp coef $\pm$ 22%/-82%.

SYMBOL	PART NO.	DESCRIPTION
C646		Ceramic: 1000pF $\pm$ 20% 50 VDCW, temp coef $\pm$ 22%/-82%.
C647		Ceramic: 0.1 $\mu$ F $\pm$ 20% 25 VDCW, temp coef $\pm$ 22%/-82%.
C649 and C650		Electrolytic: 22 $\mu$ F $\pm$ 20% 16 VDCW.
C651 and C652		Ceramic: 0.47 $\mu$ F $\pm$ 20% 25 VDCW, temp coef $\pm$ 30%/-80%.
C653 and C654		Tantalum: 2.2 $\mu$ F $\pm$ 20% 16 VDCW.
C655 and C656		Electrolytic: 10 $\mu$ F $\pm$ 20% 25 VDCW.
C657 and C658		Ceramic: 0.047 $\mu$ F $\pm$ 20% 50 VDCW, temp coef $\pm$ 22%/-82%.
C659 and C660		Tantalum: 1 $\mu$ F $\pm$ 20% 16 VDCW.
C661 thru C664		Ceramic: 0.1 $\mu$ F $\pm$ 20% 25 VDCW, temp coef $\pm$ 22%/-82%.
C665 and C666		Ceramic: 0.1 $\mu$ F $\pm$ 10% 25 VDCW, temp coef $\pm$ 15%.
C667		Tantalum: 1 $\mu$ F $\pm$ 20% 16 VDCW.
C670		Ceramic: 3300 pF $\pm$ 10% 50 VDCW, temp coef $\pm$ 15%.
C701 thru C706		Ceramic: 0.1 $\mu$ F $\pm$ 20% 25 VDCW, temp coef $\pm$ 22%/-82%.
C707		Ceramic: 47 pF $\pm$ 5% 50 VDCW, temp coef 0 $\pm$ 30 PPM/ $^{\circ}$ C.
C708 and C709		Ceramic: 12 pF $\pm$ 20% 25 VDCW, temp coef 0 $\pm$ 30 PPM/ $^{\circ}$ C.
C710		Ceramic: 47 pF $\pm$ 5% 50 VDCW, temp coef 0 $\pm$ 30 PPM/ $^{\circ}$ C.
C711		Ceramic: 0.1 $\mu$ F $\pm$ 20% 25 VDCW, temp coef $\pm$ 22%/-82%.
C712 and C713		Ceramic: 100 pF $\pm$ 5% 50 VDCW, temp coef 0 $\pm$ 30 PPM/ $^{\circ}$ C.
C714		Ceramic: 0.1 $\mu$ F $\pm$ 20% 25 VDCW, temp coef $\pm$ 22%/-82%.
C715 thru C719		Tantalum: 1 $\mu$ F $\pm$ 20% 16 VDCW.
C720 thru C722		Ceramic: 0.1 $\mu$ F $\pm$ 20% 25 VDCW, temp coef $\pm$ 22%/-82%.
C726 and C727		Ceramic: 0.1 $\mu$ F $\pm$ 20% 25 VDCW, temp coef $\pm$ 22%/-82%.
C728 thru C743		Ceramic: 100 pF $\pm$ 5% 50 VDCW, temp coef 0 $\pm$ 30 PPM/ $^{\circ}$ C.
C744 and C745		Ceramic: 0.1 $\mu$ F $\pm$ 20% 25 VDCW, temp coef $\pm$ 22%/-82%.
C746		Ceramic: 1000 pF $\pm$ 10% 50 VDCW, temp coef $\pm$ 15%.
----- DIODES -----		
CD601 and CD602		POWER Supply rectification diode: sim to SANKEN SFPM-64V.
CD603		Zener 900mW 22 V: sim to Hitachi HZF22.

\*COMPONENTS, ADDED, DELETED OR CHANGED BY PRODUCTION CHANGES

Continued

SYMBOL	EGE PART NO.	DESCRIPTION
CD604		Silicon fast recovery (2 diodes in series): sim to TOSHIBA ISS300.
CD701 thru CD705		Silicon fast recovery (2 diodes in series): sim to TOSHIBA ISS302.
CD709 and CD710		Silicon fast recovery (2 diodes in series): sim to TOSHIBA ISS302.
CD711		Silicon fast recovery (2 diodes in series): sim to TOSHIBA ISS300.
CD712		Zener 900mW 22 V: sim to Hitachi HZF12.
CX701 and CX702		EMI Filter.
F601		Fuse, 5A.
----- INTEGRATED CIRCUITS -----		
IC601		Audio Signal PROCESSOR.
IC602 and IC603		Linear Audio Amplifier: sim to NJRC 3403. PC1230H2.
IC604		AF Power Amplifier: sim to NEC UPC2500H.
IC605		Linear Positive Voltage Regulator: sim to NJRC NJM78L09UA.
IC606		Linear: Positive Voltage Regulator; sim to MOTOROLA MC7805CT.
IC607		Linear: Positive Voltage Regulator; sim to SANYO L78M05T.
IC608		Linear: Positive Voltage Regulator; sim to SANYO L78M09T.
IC609		Linear Positive Voltage Regulator: sim to NJRC NJM78L09UA.
IC610		Reset Circuit: sim to MITSUMI PST575.
IC611 and IC612		Bilateral Switch: sim to TOSHIBA TC4S66F.
IC701		CPU: sim to HITACHI HD6475328F.
IC702		CPU: sim to HITACHI HD6473308RF.
IC703		ASIC: sim to TOSHIBA TC24SC090AF.
IC704		DECODER: Sim to MOTOROLA MC74HC139.
IC705		RS485 Driver/Receiver: sim to NS AS75176.
IC706		RS232 Driver/Receiver: sim to MAXIM MA232EWE.
IC707		FLASH MEMORY: sim to INTEL N28F020.
IC708		EEPROM: sim to HITACHI HN58C66FP.
IC709		RAM: sim to SONY CXK58257AM.
IC711		Inverter: sim to MOTOROLA MC74HC04.
IC712		Silicon Serial Number: sim to DALLAS DS2400.
IC713		Inverter: sim to HITACHI HD74LS04FP.
----- JACKS -----		
J701		Connector: 18 pins.
J702 and J703		Connector: 24 pins.
J704		Connector: 4 pins.
J706		Connector: 10 pins.
J707		Connector: 13 pins.

SYMBOL	EGE PART NO.	DESCRIPTION
J708		Connector: 5 pins.
K601		Relay: sim to TAKAMIZAWA JY9H-K.
----- RESISTORS -----		
R601		Metal film: 15k ohms ±5% 100 VDCW, 1/16W.
R602		Metal film: 33K ohms ±5% 100 VDCW, 1/16W.
R603		Metal film: 68k ohms ±5% 100 VDCW, 1/16W.
R604		Metal film: 120K ohms ±5% 100 VDCW, 1/16W.
R605		Metal film: 270K ohms ±5% 100 VDCW, 1/16W.
R606		Metal film: 56K ohms ±5% 100 VDCW, 1/16W.
R607		Metal film: 150K ohms ±5% 100 VDCW, 1/16W.
R608 and R609		Metal film: 22k ohms ±5% 100 VDCW, 1/16W.
R610 and R611		Metal film: 10k ohms ±5% 100 VDCW, 1/16W.
R612 and R613		Metal film: 39k ohms ±5% 100 VDCW, 1/16W.
R614		Metal film: 4.7K ohms ±5% 100 VDCW, 1/16W.
R615		Metal film: 100k ohms ±5% 100 VDCW, 1/16W.
R616		Metal film: 470K ohms ±5% 100 VDCW, 1/16W.
R617		Metal film: 3.3 M ±10% 200 VDCW, 1/10W.
R618 and R619		Metal film: 100k ohms ±5% 100 VDCW, 1/16W.
R620		Metal film: 47K ohms ±5% 100 VDCW, 1/16W.
R621		Metal film: 22k ohms ±5% 100 VDCW, 1/16W.
R622 thru R624		Metal film: 56K ohms ±5% 100 VDCW, 1/16W.
R625		Metal film: 10k ohms ±5% 100 VDCW, 1/16W.
R626		Metal film: 56k ohms ±5% 100 VDCW, 1/16W.
R627		Metal film: 150k ohms ±5% 100 VDCW, 1/16W.
R628 and R629		Metal film: 100K ohms ±5% 100 VDCW, 1/16W.
R630		Metal film: 3.3M ohms ±10% 200 VDCW, 1/10W.
R631		Metal film: 47k ohms ±5% 100 VDCW, 1/16W.
R632		Metal film: 100K ohms ±5% 100 VDCW, 1/16W.
R633		Metal film: 22k ohms ±5% 100 VDCW, 1/16W.
R634		Metal film: 1M ohms ±5% 100 VDCW, 1/16W.
R635		Metal film: 6.8k ohms ±5% 100 VDCW, 1/16W.
R636 thru R639		Metal film: 10k ohms ±5% 100 VDCW, 1/16W.
R640		Metal film: 3.3k ohms ±5% 100 VDCW, 1/16W.

SYMBOL	EGE PART NO.	DESCRIPTION
R641		Metal film: 10k ohms ±5% 100 VDCW, 1/16W.
R642		Metal film: 22k ohms ±5% 100 VDCW, 1/16W.
R643 and R644		Metal film: 22 ohms ±5% 100 VDCW, 1/16W.
R645 and R646		Metal film: 1.0k ohms ±5% 100 VDCW, 1/16W.
R647		Metal film: 8.2k ohms ±5% 100 VDCW, 1/16W.
R648		Metal film: 10k ohms ±5% 100 VDCW, 1/16W.
R649		Metal film: 1M ohms ±5% 100 VDCW, 1/16W.
R650 and R651		Metal film: 680 ohms ±5% 100 VDCW, 1/16W.
R652		Metal film: 15K ohms ±5% 100 VDCW, 1/16W.
R653		Metal film: 15K ohms ±5% 100 VDCW, 1/16W.
R654		Metal film: 15K ohms ±5% 100 VDCW, 1/16W.
R655		Metal film: 56k ohms ±5% 100 VDCW, 1/16W.
R656		Metal film: 1.0k ohms ±5% 100 VDCW, 1/16W.
R657		Carbon film: 560 ohms ±5% 200 VDCW, 1/4W.
R701 thru R703		Metal film: 100 ohms ±5% 100 VDCW, 1/16W.
R704		Metal film: 68k ohms ±5% 100 VDCW, 1/16W.
R705		Metal film: 100 ohms ±5% 100 VDCW, 1/16W.
R706 and R707		Metal film: 1.0k ohms ±5% 100 VDCW, 1/16W.
R709 and R710		Metal film: 100 ohms ±5% 100 VDCW, 1/16W.
R718		Metal film: 4.7k ohms ±5% 100 VDCW, 1/16W.
R719		Metal film: 100k ohms ±5% 100 VDCW, 1/16W.
R720		Metal film: 10k ohms ±5% 100 VDCW, 1/16W.
R721		Metal film: 47k ohms ±5% 100 VDCW, 1/16W.
R724 and R725		Metal film: 2.7K ohms ±5% 100 VDCW, 1/16W.
R726		Metal film: 1M ohms ±5% 100 VDCW, 1/16W.
R729 and R730		Metal film: 0 ohms.
R732		Metal film: 0 ohms.
R733		Metal film: 4.7K ohms ±5% 100 VDCW, 1/16W.
R734		Metal film: 1.0k ohms ±5% 100 VDCW, 1/16W.
R735		Metal film: 4.7K ohms ±5% 100 VDCW, 1/16W.

SYMBOL	EGE PART NO.	DESCRIPTION
R736		Metal film: 6.8K ohms ±5% 100 VDCW, 1/16W.
R737 thru R740		Metal film: 10k ohms ±5% 100 VDCW, 1/16W.
R741		Metal film: 27k ohms ±5% 100 VDCW, 1/16W.
R742 and R743		Metal film: 4.7K ohms ±5% 100 VDCW, 1/16W.
R744 and R745		Metal film: 470 ohms ±5% 100 VDCW, 1/10W.
R747		Metal film: 0 ohms.
R748		Metal film: 10K ohms ±5% 100 VDCW, 1/16W.
R749		Metal film: 100K ohms ±5% 100 VDCW, 1/16W.
R750 and R751		Metal film: 22k ohms ±5% 100 VDCW, 1/16W.
R752 and R753		Metal film: 10k ohms ±5% 100 VDCW, 1/16W.
SW601		Slide Switch.
SW701		Slide Switch.
----- TRANSISTORS -----		
TR602		Transistor NPN: sim to SANYO 2SC3398.
TR603		Transistor NPN: sim to NEC 2SD596 .
TR701		Transistor NPN: sim to TOSHIBA RN2301.
TR702 thru TR712		FET: sim to NEC 2SK1582.
TR713 and TR713		Transistor NPN: sim to TOSHIBA 2SC2859.
TR715 and TR716		Transistor NPN: sim to NEC 2SC3736.
----- CRYSTAL -----		
X701		Crystal: 9.8304 MHz CP12A.

800 MHz SYSTEM CONTROL LOGIC/IF BOARD

IF SECTION  
CMF-138P

SYMBOL	PART NO.	DESCRIPTION
-----CAPACITORS-----		
C501	<b>NOTE:</b> Parts listed are for reference only. Refer to Service Section for serviceable parts	Ceramic: 1000 pF ±10% 50 VDCW temp coef ±15%.
C502		Ceramic: 5 pF ±0.25 pF 50 VDCW temp coef 0±60 PPM.
C503		Ceramic: 1.5 pF ±0.25 pF 50 VDCW temp coef 0±250 PPM.
C504		Ceramic: 7 pF ±0.5 pF 50 VDCW temp coef 0±60 PPM.
C505		Ceramic: 6 pF ±0.5 pF 50 VDCW temp coef 0±60 PPM.
C506		Ceramic: 5 pF ±0.25 pF 50 VDCW temp coef 0±60
C507		Ceramic: 1.5 pF ±0.25 pF 50 VDCW temp coef 0±250 PPM.
C508		Ceramic: 5 pF ±0.25 pF 50 VDCW temp coef 0±60 PPM.
C509 thru C512		Ceramic: 1000 pF ±10% 50 VDCW temp coef ±15%.
C513 and C514		Ceramic: 0.75 pF ±0.25 pF 50 VDCW temp coef 0±250 PPM.
C515 and C516		Ceramic: 1000 pF ± 10% 50 VDCW temp coef ±15%.
C521		Ceramic: 1000 pF ±10% 50 VDCW temp coef ±15%.
C522 and C523		Ceramic: 0.1 μF ±10% 25 VDCW temp coef ±15%.
C524		Ceramic: 1000 pF 10% 50 VDCW temp coef 15%.
C525		Ceramic: 15 pF ± 5% 50 VDCW temp coef 0±60 PPM.
C526		Ceramic: 1000 pF ±10% 50 VDCW temp coef ±15%.
C527		Ceramic: 33 pF ± 5% 50 VDCW temp coef 0±60 PPM.
C528		Ceramic: 15 pF ±5% 50 VDCW temp coef 0±60 PPM.
C529		Ceramic: 1000 pF ± 10% 50 VDCW temp coef 15%.
C530		Ceramic: 0.01μF ±10% 50 VDCW temp coef ±15%.
C531	Ceramic: 1 pF ± 0.25 pF 50 VDCW temp coef 0±250 PPM.	
C553	Ceramic: 0.01μF ±10% 50 VDCW temp coef ±15%.	
C554 thru C556	Ceramic: 0.1 μF ±10% 25 VDCW temp coef ±15%	
C557	Ceramic: 15 pF ±5% 50 VDCW temp coef 0±60 PPM.	
C558 and C559	Ceramic: 0.1μF ±10% 25 VDCW temp coef ±15%.	
C560	Ceramic: 1000 pF ±10% 50 VDCW temp coef ±15%.	
C561 thru C565	Ceramic: 0.1μF ±10% 25 VDCW temp coef ±15%.	
C567	Electrolytic: 10μF ±20% 16 VDCW.	

SYMBOL	PART NO.	DESCRIPTION
C571 and C572		Ceramic: 0.1μF ±10% 25 VDCW temp coef ±15%.
C573		Electrolytic: 10μF ±20% 16 VDCW.
-----FILTERS-----		
FL501 and FL502		Crystal Filter: 82.2 MHz.
FL503		Ceramic: Filter: 455 kHz.
FL504		Ceramic: Filter: 455 kHz.
-----INTEGRATED CIRCUITS-----		
IC501		Linear, IF Amplifier Detector; sim to TOSHIBA TA31132F.
IC502		Linear, Dual OP AMP; sim to NJRC NJM3404.
IC503		Linear, Positive Voltage Regulator; sim to NJRC NJM78L09UA.
-----CONNECTORS-----		
P501		Connector: 30 Pins.
-----COILS-----		
L501		Coil: RF 1 μH ±20%.
L502		Coil: RF .
L503		Coil: RF .
L504 and L505		Coil: RF .
L506		Coil: RF .
L507		Coil: RF .
L521		Coil: RF .
L522		Coil: RF 0.22 μH ±10%.
L523		Coil: RF .
-----RESISTORS -----		
R501		Metal film: 82 ohms ±5% 100 VDCW, 1/10W.
R502		Metal film: 18 ohms ±5% 100 VDCW, 1/10W.
R503		Metal film: 3.9K ohms ±5% 100 VDCW, 1/16W.
R505		Metal film: 150K ohms ±5% 100 VDCW, 1/16W.
R506		Metal film: 330 ohms ±5% 100 VDCW, 1/16W.
R507 and R508		Metal film: 10K ohms ±5% 100 VDCW, 1/16W.
R509		Metal film: 220 ohms ±5% 100 VDCW, 1/16W.
R510		Metal film: 5.6K ohms ±5% 100 VDCW, 1/16W.
R511		Metal film: 330 ohms ±5% 100 VDCW, 1/16W.
R521		Metal film: 15K ohms ±5% 100 VDCW, 1/16W.
R522		Metal film: 4.7K ohms ±5% 100 VDCW, 1/16W.
R523		Metal film: 1.8K ohms ±5% 100 VDCW, 1/16W.
R524		Metal film: 100 ohms ±5% 100 VDCW, 1/16W.
R525		Metal film: 33 ohms ±5% 100 VDCW, 1/16W.
R526		Metal film: 1K ohms ±5% 100 VDCW, 1/16W.
R527		Metal film: 4.7K ohms ±5% 100 VDCW, 1/16W.
R528		Metal film: 10K ohms ±5% 100 VDCW, 1/16W.
R529		Metal film: 1K ohms ±5% 100 VDCW, 1/16W.
R530		Metal film: 10K ohms ±5% 100 VDCW, 1/16W.
R531		Metal film: 100 ohms ±5% 100 VDCW, 1/16W.
R552		Metal film: 1.5K ohms ±5% 100 VDCW, 1/16W.
R556 and R557		Metal film: 1.5K ohms ±5% 100 VDCW, 1/16W.
R559		Metal film: 820 ohms ±5% 100 VDCW, 1/16W.
R560		Metal film: 18K ohms ±5% 100 VDCW, 1/16W.
R562		Metal film: 10K ohms ±5% 100 VDCW, 1/16W.

SYMBOL	PART NO.	DESCRIPTION
R563		Metal film: 6.8K ohms ±5% 100 VDCW, 1/16W.
R564		Metal film: 1.2K ohms ±5% 100 VDCW, 1/16W.
R565		Metal film: 5.6K ohms ±5% 100 VDCW, 1/16W.
R566		Metal film: 0 ohms, 1/16W.
RV501		Variable: 10K ohms.
-----TRANSISTORS-----		
TR501 and TR502a		N-Channel, field effect 2SK1577.
TR503		Silicon, NPN; sim to NEC 2SC2223.
TR504 and TR505		Silicon, NPN; sim to HITACHI 2SC2620.
-----CRYSTALS-----		
X501		Quartz crystal: 82.655 MHz.
XS501A and XS501B		Crystal Socket.

\*COMPONENTS, ADDED, DELETED OR CHANGED BY PRODUCTION CHANGES

COMPONENT SIDE

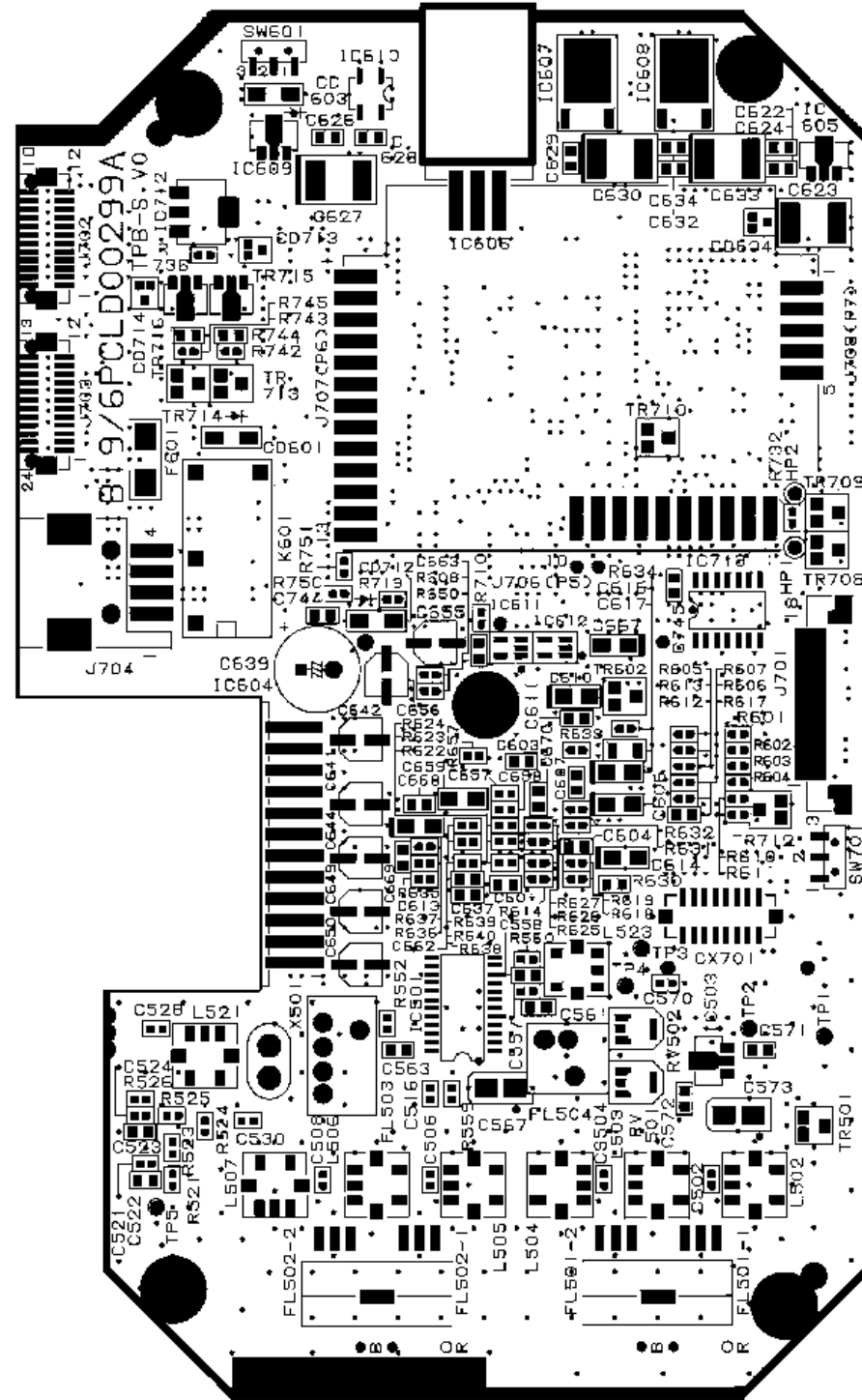

SOLDER SIDE

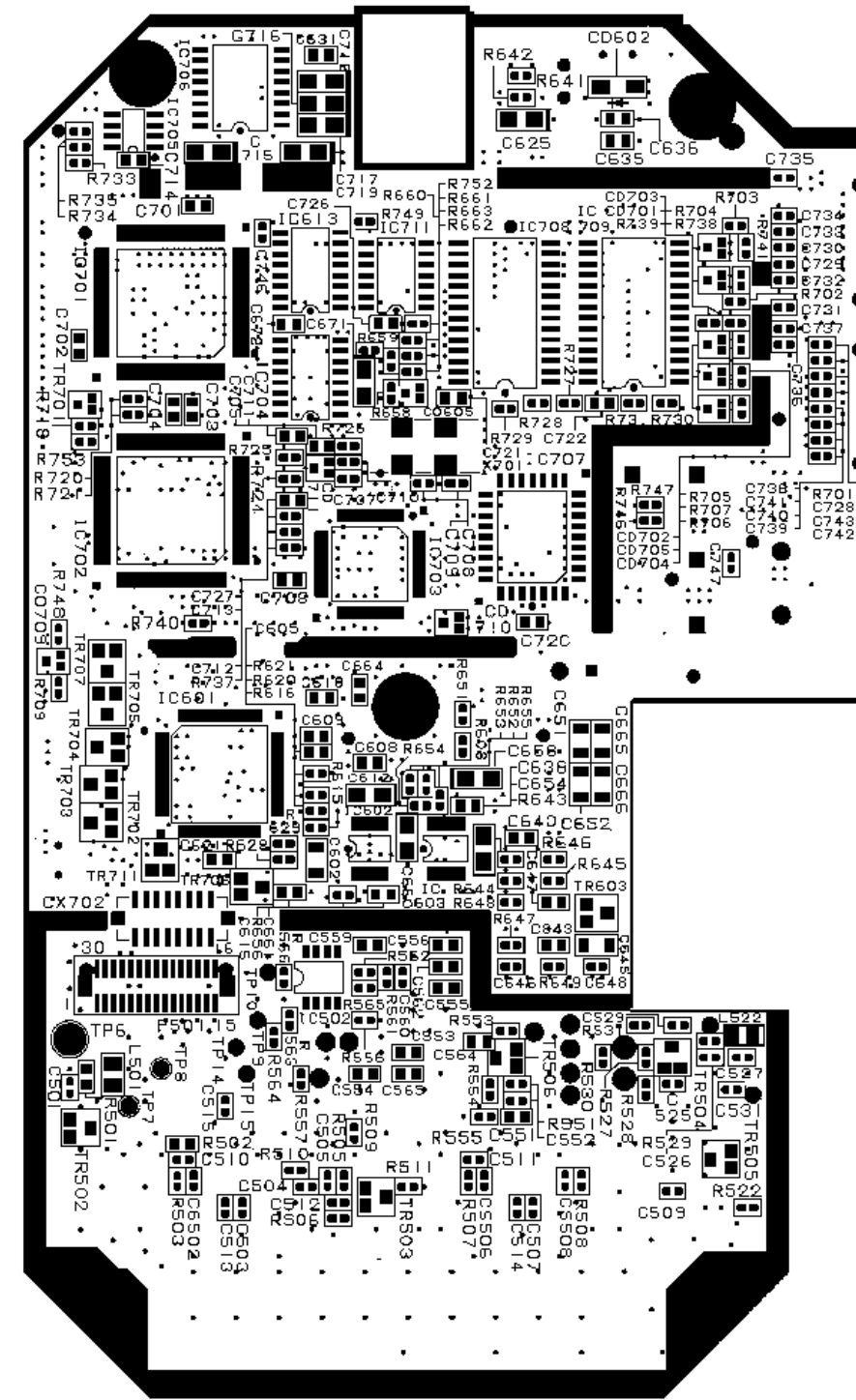

SYSTEM CONTROL LOGIC/IF/AUDIO BOARD

**SCHEMATIC DIAGRAM**

**LBI-39072**

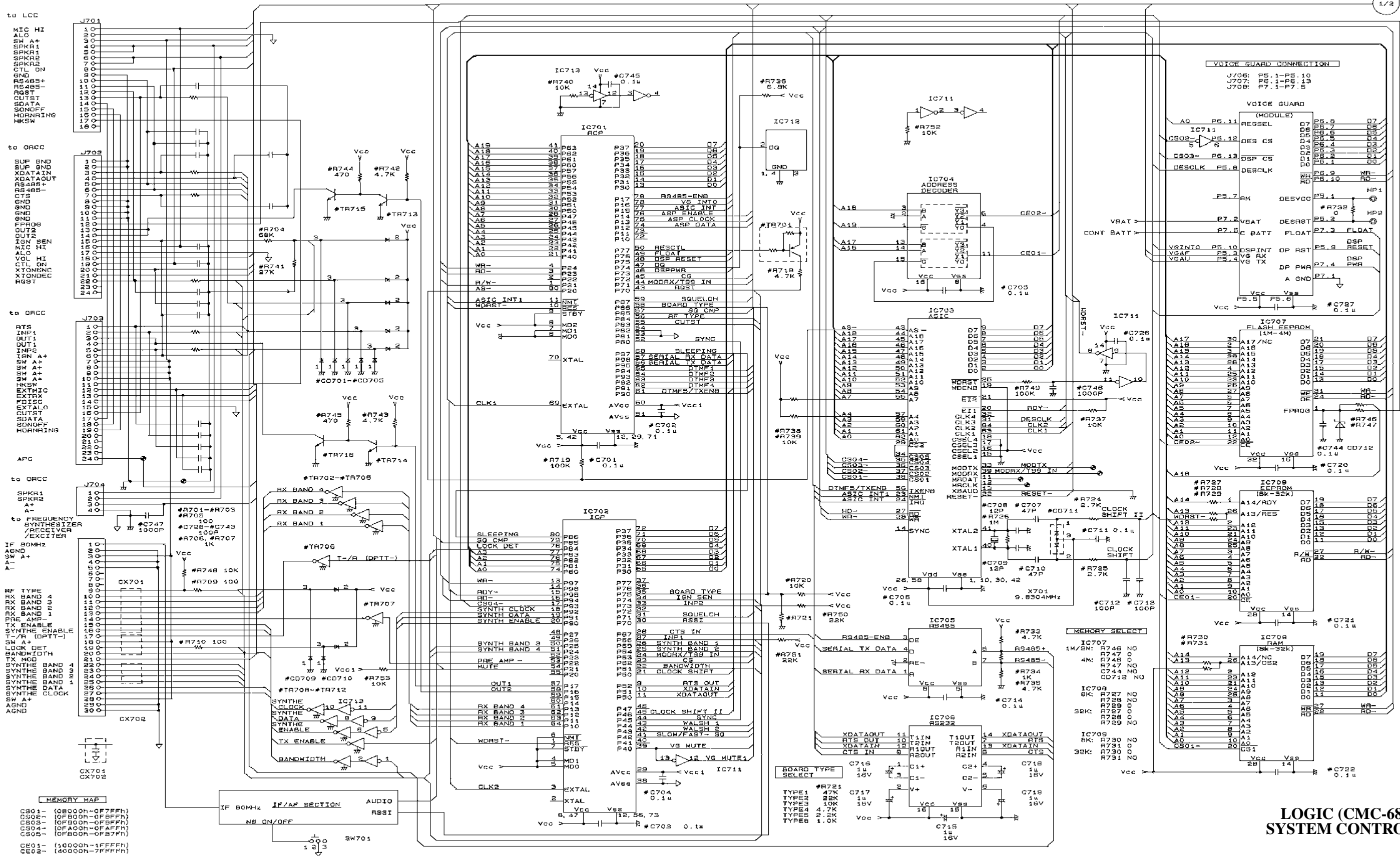

**LOGIC (CMC-682) SYSTEM CONTROL**

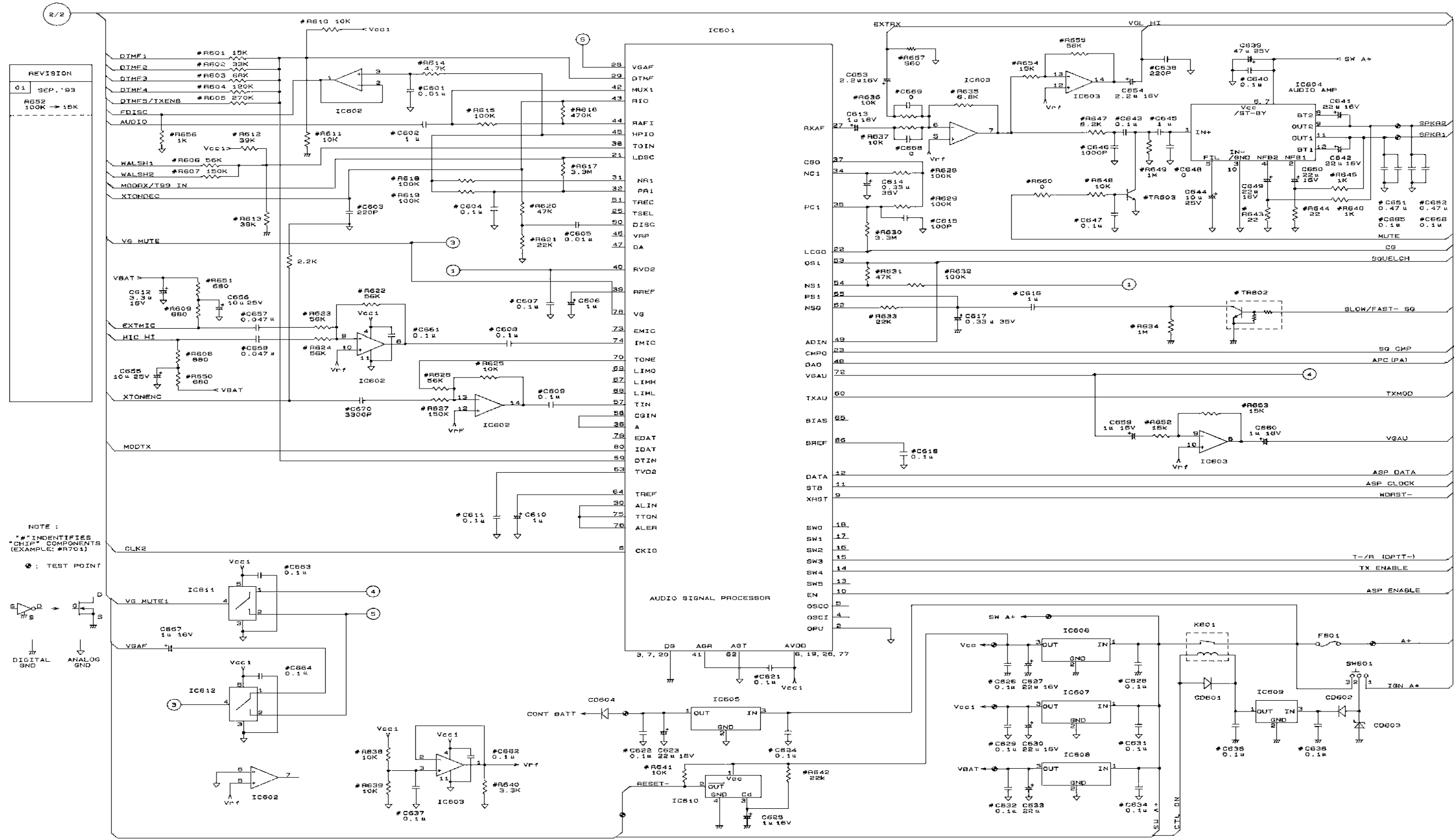

**LOGIC (CMC-682)  
SYSTEM CONTROL**

(DD00-CMC-682 2/2)

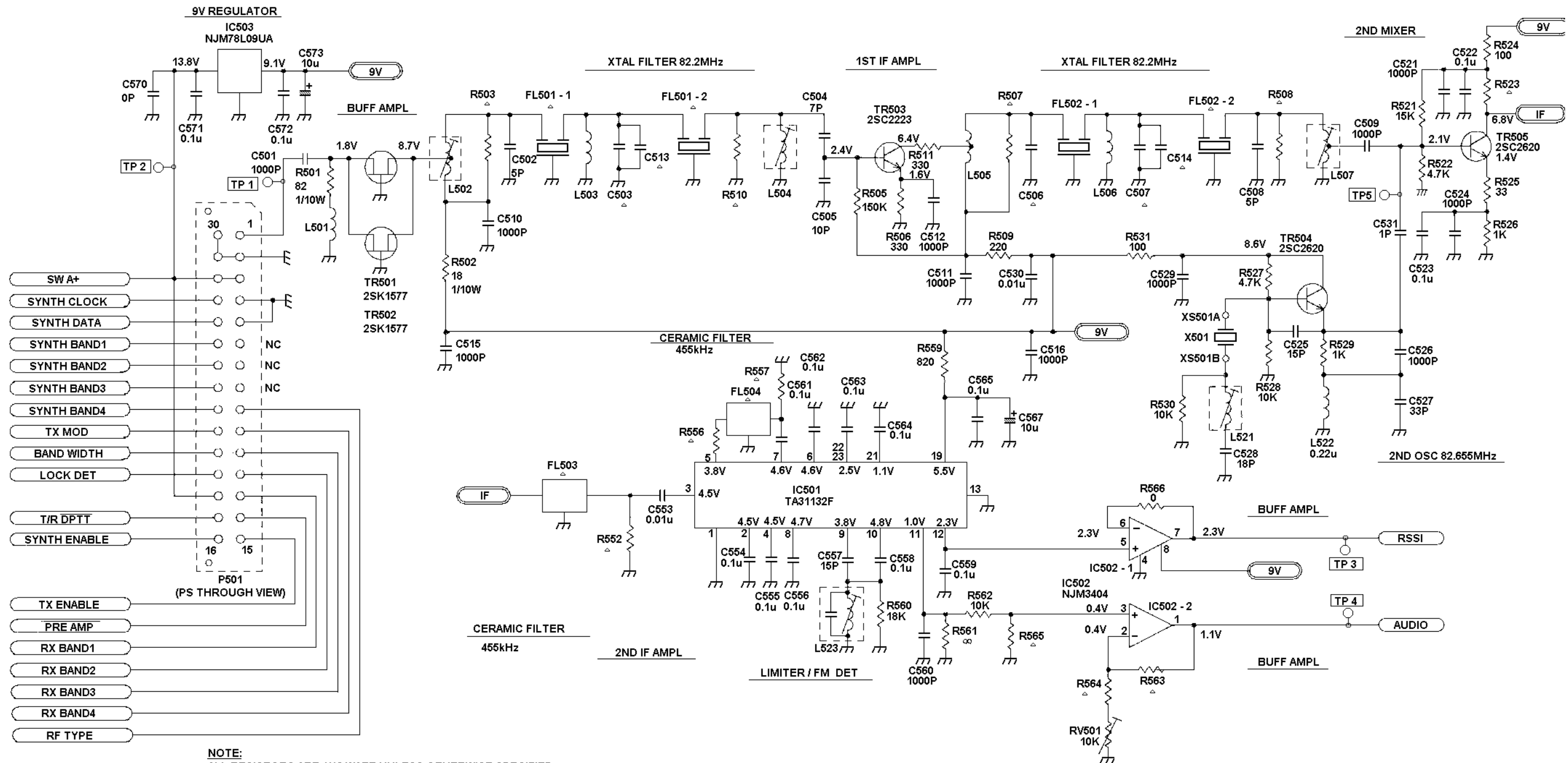

**NOTE:**  
 ALL RESISTORS ARE 1/16 WATT UNLESS OTHERWISE SPECIFIED.  
 RESISTOR VALUES IN Ω UNLESS FOLLOWED BY MULTIPLIER K OR M.  
 CAPACITOR VALUES IN F UNLESS FOLLOWED BY MULTIPLIER u, n OR P.  
 INDUCTANCE VALUES IN H UNLESS FOLLOWED BY MULTIPLIER m, μ OR n.

IF(CMF-138)

(DD0-CMF-138)