

Maintenance Manual

MASTR[®] III

MULTIPLE RECEIVER SHELF 188D5452G1

TABLE OF CONTENTS

SystemModule (Group 5)	LBI-38764
Power Module	LBI-38752

TABLE OF CONTENTS

	<u>Page</u>
SPECIFICATIONS	2
DESCRIPTION	2
BACKPLANE BOARD 188D5329G1	2
INTERFACE BOARD 188D5139G1	3
POWER MODULE INTERCONNECT BOARD 19C852485G1	3
SYSTEM MODULE 19D902590G5	3
POWER MODULE 19D902589G2	3
POWER HARNESS 19B803412	3
INSTALLATION (APPLICATION)	3
TROUBLESHOOTING	3
SYSTEM OPERATION	3
EDACS VOTER	3
SECOND RECEIVER	4
CONVENTIONAL VOTER	4
MONITOR PANEL	4
CHANNEL GUARD	4
BATTERY ALARM TONE	4
SYSTEM INTERFACES	4
RECEIVER SYNTHESIZER	4
GETC INTERFACE	4
SECOND RECEIVER INTERFACE	4
MONITOR PANEL	4
PROGRAMMING/DIAGNOSTICS SERIAL PORTS	5

NOTICE!

This manual covers Ericsson and General Electric products manufactured and sold by Ericsson Inc.

NOTICE!

Repairs to this equipment should be made only by an authorized service technician or facility designated by the supplier. Any repairs, alterations or substitution of recommended parts made by the user to this equipment not approved by the manufacturer could void the user's authority to operate the equipment in addition to the manufacturer's warranty.

NOTICE!

The software contained in this device is copyrighted by Ericsson Inc. Unpublished rights are reserved under the copyright laws of the United States.

This manual is published by **Ericsson Inc.**, without any warranty. Improvements and changes to this manual necessitated by typographical errors, inaccuracies of current information, or improvements to programs and/or equipment, may be made by **Ericsson Inc.**, at any time and without notice. Such changes will be incorporated into new editions of this manual. No part of this manual may be reproduced or transmitted in any form or by any means, electronic or mechanical, including photocopying and recording, for any purpose, without the express written permission of **Ericsson Inc.**

TABLE OF CONTENTS
Continued

	<u>Page</u>
STATION POWER SUPPLY	5
Power Supply Inputs	5
Power Supply Module Outputs	5
CONTROLS AND INDICATORS	5
Controls	5
Indicators	5
CIRCUIT ANALYSIS	5
INTERFACE BOARD	5
Line Interconnect	5
Audio Monitor Panel Amplifier	5
Serial Communications	5
Flag Status Register	5
Output Register	5
Handset Interface	5
Squelch Adjustment	5
Relay	6
M/R SHELF ALIGNMENT	6
MAINTENANCE	6
PARTS LISTS:	6
INTERFACE BOARD 188D5139G1	6
MULTIPLE RECEIVER SHELF ASSEMBLY 188D5452G1	7
BACKPLANE BOARD 188D5329G1	7
POWER MODULE INTERCONNECT BOARD 19C852485G1	7
MONITOR PANEL 188D5495G1	7
IC DATA	8
POWER HARNESS	10
GETC HARNESS	11
LINE-OUT CABLE	13
DATA CABLE	13
SIGNAL CABLE	15
SECOND RECEIVER POWER CABLE	15
MONITOR PANEL HARNESS	16
ASSEMBLY DIAGRAMS:	16
MONITOR PANEL 188D5495G1	16
MULTIPLE RECEIVER SHELF ASSEMBLY 188D5452G1	17

TABLE OF CONTENTS
Continued

	<u>Page</u>
OUTLINE DIAGRAMS:	17
BACKPLANE BOARD 188D5329G1	17
INTERFACE BOARD 188D5139G1	21
POWER MODULE INTERCONNECT BOARD 19C852485G1	27
SCHEMATIC DIAGRAMS:	18
BACKPLANE BOARD 188D5329G1	18
INTERFACE BOARD 188D5139G1	22
POWER MODULE INTERCONNECT BOARD 19C852485G1	27
INSTALLATION/APPLICATION DIAGRAMS:	28
Assembly of Multiple Receiver Shelf For The MASTR II Indoor Cabinet	28
Cabinet View Of Buffer Board, System Panel And Control Channel Monitor	30
EDACS - Multiple Receiver Shelf with GETC's	31
Monitor Panel	32
GETC Shelf Mounting In Standard Cabinet And Interconnection Diagram	33
83" Cabinet and 86" Open Rack	34
69" Cabinet	35
69" and 83" Conventional Cabinet	36
Multiple Receiver Shelf, 37" MASTR III Indoor Cabinet	37
EDACS Modem or Asynchronous RS-232, 83" Cabinet or 86" Open Rack	38
EDACS Modem or Asynchronous RS-232, 69" Cabinet	39
Synchronous RS-232, 83" Cabinet or 86" Open Rack	40
Synchronous RS-232, 69" Cabinets	41
Second Receiver	42
Multiple Receiver - Simulcast Ch. 1 - 20	43
Multiple Receiver - Simulcast Ch. 21 - 24	44
Multiple Receiver - Cross-Connect Voter	45
Multiple Receiver - Cross-Connect Voter	46

DESCRIPTION

The MASTR III Multiple Receiver is a dedicated receiver designed in the likeness of the MASTR III Base Station. The M/R Shelf incorporates the Base Station modular structure and is completely compatible with it and previous designs. The MASTR III Multiple Receiver contains a control section consisting of a Backplane Board, Interface Board, Power Module Interconnect Board, System Module, and Power Module. The backplane also connects the RF Section (Receiver Synthesizer Module, Receiver Front End Module, and the Receiver IF Module), for two possible receivers. The Control Section and the RF Section combine to form the MASTR III Multiple Receiver Shelf with either one or two receivers.

The Interface Board and System Module connect to the backplane through 96-pin connectors. The Power Module connects to the Power Module Interconnect Board which is connected to the Backplane through the Power Harness. The Control Section contains eight backplane slots, four for each receiver. The Interface Board provides interconnection for local data port, handset, rear data port(s), and multifunction port(s). Four connectors, two for each receiver (terminal block and modular phone) are provided for telephone line connections to a base station or voter. Additional connectors are provided on the backplane for GETC's, second receivers and test connectors.

The Control Section uses programmable microcomputer technology to control the MASTR III Multiple Receiver shelf receiver and audio processor. The System Module contains a **Digital Signal Processor (DSP)** Module used for signal processing, tone detection, and tone creation. The basic Control

SPECIFICATIONS*

POWER: Shelves with two receivers

Duty Cycle	100%
AC Input Power	0.75 Amperes at 120 Vac 20%, 60 Hz 0.39 Amperes at 230 Vac 15%, 50 Hz
DC Input Power	3.10 Amperes at 13.8 Vdc 20% 3.75 Amperes at 11.0 Vdc 20%

AUDIO RESPONSE

Receiver to Line	+1, -3 dB from -6 dB per octave response for 300 to 3000 Hz referenced to 1 kHz
Receiver to Speaker	+2, -8 dB from -6 dB per octave response for 300 to 3000 Hz referenced to 1 kHz
Line Output Level	-19 dBm to +6 dBm
Line Interface	2 wire

LINE TERMINATION IMPEDANCE

600 ohms

OPERATING TEMPERATURE

-30 C to +60 C

HUMIDITY

95%

DISTORTION

Less than 2%

SERVICE SPEAKER

2.25 watts at 8 ohms

PANEL DIMENSIONS (H x W)

7.00 x 19.0 inches (4 Rack Units)

*These specifications are intended primarily for use by service personnel. Refer to the appropriate Specification Sheet for the complete specifications.

WARNING

No one should be permitted to handle any portion of the equipment that is supplied with high voltage; or to connect any external apparatus to the units while the units are supplied with power. KEEP AWAY FROM LIVE CIRCUITS.

Section can be programmed to receive eight frequencies per receiver, with only one active at a time on each receiver. Functions provided by the Control Section include the following:

- Two wire audio.
- Voting tone.
- Remote programming.
- Future Expansion Ports.
- Channel Guard.
- Squelch Operated Relay (SOR) output.
- DTMF over-air tone decoding.
- Battery Alarm Tone.

BACKPLANE BOARD 188D5329G1

The MASTR III Multiple Receiver backplane board is a passive printed wiring board that mounts to the multiple receiver shelf. When viewed from the front, the eight slots connecting the RF and System Modules are assigned from left to right as follows:

- Receiver Synthesizer Module_L J11 19D902781
- Receiver Front End Module_L J12 19D902782
- Receiver IF Module_L J13 19D902783
- System Module_L J14 19D902590G5

- System Module_R J24 19D902590G5
- Receiver Synthesizer Module_R J23 19D902781
- Receiver Front End Module_R J22 19D902782
- Receiver IF Module_R J21 19D902783

In those applications where using one receiver, only the left side is populated. Connector J31 is used to connect the Interface Board to the Backplane Board.

The rest of the connectors on the rear are used for the following applications:

- GETC_L P11
- Voice Guard_L P12
- Test Connector_L P13
- Second Receiver_L P14
- Power_L J15
- Second Receiver_R P24
- Test Connector_R P23
- Voice Guard_R P22
- GETC_R P21
- Power_R J25

INTERFACE BOARD 188D5139G1

The Interface Board mounts horizontally above the backplane and connects J31 of the Backplane to P101 of the Interface Board. The board is functionally and physically segmented into three sections (left and right receiver sections, and control section). The Interface Board provides the following functions:

- Telephone line interface.
- Left and right receiver coordination.
- Remote programming of left and right system modules through the rear data ports.
- Local programming of left and right system modules through the front data ports.
- General Purpose Connectors (future expansion ports).
- Digital adjustment of receiver squelch.
- Squelch Operated Relay (SOR).

The Interface Board communicates with components outside the shelf through the following connectors:

- Line Interface Connector_L J101
- Line Interface Terminal Board_L TB101
- General Purpose Connector_L J102
- Rear Left Programming/Diagnostics Connector J103
- Line Interface Connector_R J301
- Line Interface Terminal Board_R TB301
- General Purpose Connector_R J302
- Rear Right Programming/Diagnostics Connector J303
- Handset Connector J207
- Front Programming/Diagnostics Connector J208

POWER MODULE INTERCONNECT BOARD M9C852485G1

The Power Module Interconnect Board is a passive printed wiring board that connects the Power Module to the Backplane through the Power Harness. The harness connects J2 on the Power Module Interconnect Board to J15 on the Backplane for the left side or J25 for the right side.

SYSTEM MODULE 19D902590G5

The System Module contains all audio processing and core control electronics of the control section. The System Module is equipped with a DSP board that rides "piggyback" on the 19D903771G3 System Board. Refer to Controls and Indicators for description of switches and LED's (see Table of Contents). For complete information on the System Module, refer to Maintenance Manual LBI-38764.

POWER MODULE 19D902589G2

The Power Module contains switching regulators for the +5V, +12V, and -12V DC supplies. The output of the +12V and -12V are further regulated to provide +5V and -5V required by the analog components. See Maintenance Manual LBI-38752 for complete information on the power module.

POWER HARNESS 19B803412

The wiring within the MASTR III Multiple Receiver has been minimized due to its modular architecture. The Power Harness provides independent wiring for each receiver between the Power Module Interconnect Board and the Backplane.

INSTALLATION

The MASTR III Multiple Receiver may be installed in one of three primary applications: EDACS Voter, Second Receiver, and Conventional Voter. Refer to the Application/Installation Diagram (see Table of Contents) for descriptions.

TROUBLE SHOOTING

SUBJECT	SYMPTOM	SOLUTION
Power	Not receiving power to the MASTR III Multiple Receiver shelf.	<ul style="list-style-type: none"> • Check fuses. • Check that power supply is properly connected and on. • Check that power module is properly installed. • Check for +5Vdc and +12Vdc from power module. • Check that power harness is properly connected.
Reset	Hardware and/or software reset not functioning properly.	<ul style="list-style-type: none"> • Hardware: Check toggle switch for loose connection. • Software: Ensure that personality is properly loaded into system module.
Programmability/Select	Error in loading PC Programmer personality.	<ul style="list-style-type: none"> • Ensure that correct system module is selected for front panel local programming or the PC is connected to the correct rear programming data port.
Receiver Tuning	Receiver Synthesizer LO LED flashing.	<ul style="list-style-type: none"> • Ensure the system module is programmed with the correct frequency. If the programming is correct, retune the receiver synthesizer module.
1950 Hz Voting Tone	Receiver shelf is not outputting 1950 Hz voting tone on line out.	<ul style="list-style-type: none"> • Ensure voting system is enabled in PC Programmer personality. • Check voting tone output level.
Squelch Noise	No squelch noise when SQ DEFEAT is toggled.	<ul style="list-style-type: none"> • Ensure that correct receiver is selected if monitoring through front connectors. • Check connections if in conventional mode. • In EDACS mode, hold GETC reset and check for noise.

SUBJECT	SYMPTOM	SOLUTION
Audio Reception	Not receiving audio or audio is at incorrect levels.	<ul style="list-style-type: none"> • Ensure that modules and Remote audio line output are properly connected. • Check that reference oscillator frequency is at 12.8 MHz. DO NOT ADJUST. • Check that LO frequency is at receive frequency minus 70.2 MHz and that line level is at 2dBm 2dB. • Apply an "on Channel" RF signal to the receiver modulated with a 1000 Hz tone for 3.0 kHz of FM deviation to J2 RF IN and check for audio at the Remote audio line output. • Apply a 70.2 MHz signal to the IF input modulated with a 1000 Hz tone for 3.0 kHz of FM deviation to J2 RF IN and check for audio at the Remote audio line output.

SYSTEM OPERATION

The MASTR III Multiple Receiver Shelf is programmable for several applications such as an EDACS Voter, Second Receiver, conventional or customized voter. The M/R Shelf is equipped with control and status indicators used for operation and testing. These controls allow the service technician to force the receiver to unsquelch, to disable Channel Guard, and to program the individual System Modules locally (at the shelf). The status indicators available in the M/R Shelf are LOC PGM, UN SQ, CG MONITOR, and power indicators.

There are several functions available in the MASTR III Multiple Receiver that are applicable to the different applications. These options are described in the following sections.

EDACS VOTER

In a trunked system, two types of calls may be processed: analog and digital. During an analog call, the MASTR III Multiple Receiver provides the analog voter with the received signal. If there is no analog call, the M/R Shelf signals the analog voter with a 1950 Hz voting tone. During a digital call, the M/R Shelf provides the GETC with the received digital

signal that is then sent to the digital selector while maintaining the voting tone to the analog voter.

SECOND RECEIVER

In a conventional system, the MASTR III Multiple Receiver acts as a passive second receiver. In this application, it receives a signal, processes it, and outputs it to the Base Station.

CONVENTIONAL VOTER

In a conventional system, when there is no carrier activity, the M/R Shelf provides a 1950 Hz voting tone to the analog voter. When a valid signal is received, the M/R Shelf disables the voting tone and provides the processed signal on the line out.

MONITOR PANEL

In a trunked or conventional system, the monitor panel is a passive circuit designed to pass audio from individual receivers to a speaker for monitoring. The selector can switch between a maximum of ten channels. The monitor panel also has a volume control and an on/off switch for audio.

CHANNEL GUARD

There are two types of Channel Guard (CG) available that the M/R Shelf can decode: tone and digital. The left and right receivers may be programmed with different combinations of tone and digital channel guard. When the shelf is in Channel Guard mode, only signals with the proper CG information will unquench the receiver. However, Channel Guard may be disabled by toggling the CG MONITOR switch on the front of the System Module.

Standard CG tone frequencies range from 67 Hz to 210.7 Hz (See Table 1). The MASTR III Multiple Receiver Shelf detects a 135-degree phase shift in the CG tone to determine when to mute the receiver in order to eliminate squelch tail (STE). There are also 83 digital codes available. A list of the octal codes (and their equivalent codes) is shown in Table 2.

Table 1 - Channel Guard Tone Frequencies

Standard Tone Frequencies Hz				
67.0	88.5	107.2	131.8	167.9
71.9	91.5	110.9	136.5	173.8
74.4	94.8	114.8	141.3	179.9
77.0	97.4	118.8	146.2	186.2
79.7	100.0	123.0	151.4	192.8
82.5	103.5	127.3	156.7	203.5
85.4			162.2	210.7

Table 2 - Primary and Equivalent Octal Codes

PRIM CODE	EQUIVALENT CODE	PRIM CODE	EQUIVALENT CODE	PRIM CODE	EQUIVALENT CODE
023	340,766	133	413,620	243	267,342
025	—	134	273	246	542,653
026	566	135	205,610	252	661
031	374,643	136	502,712	254	314,612,706
032	—	142	174,270	255	425
036	137	143	333	262	316,431,730
037	560,627	144	466,666	266	655
043	355	145	525	271	427,510,762
047	375,707	147	303,306,761	274	652
051	520,771	150	256,703	276	326,432
053	—	152	366,415	307	362,565
054	405,675	153	606,630	311	330,456,561
056	465,656	155	233,660	312	515,663,743
057	172	156	517,741	315	321,673
060	116,737	157	322,503	317	546,614,751
065	301	161	345,532	324	343,570
066	734	162	416,553	325	550,626
067	516,720	163	460,607,654	331	372,507
071	603,717,746	164	207,732	332	433,552
072	470,701	165	354	344	471,664,715
073	640	171	265,426	346	616,635,724
074	360,721	—	—	351	353,435
075	501,624	212	253	356	521
076	203,754	213	263,736	363	436,443,444,662
104	226,557	217	371,453,530	446	467,511,672
107	365	222	445,457,575	447	473,474,731,744
114	327,615	223	350,475,750	452	524,765
115	534,674	224	313,506,574	454	513,545,564
117	411,756	225	536	455	533,551
122	535	227	261,567		
123	632,657	231	504,631,636,745		
125	173	234	423,563,621,713	462	472,623,725
127	412,441,711	235	611,671,723	523	647,726
130	364,641	236	251,704,742	526	562,645
132	605,634,714	237	464,642,772		

BATTERY ALARM TONE

Whenever the station is operating on battery stand-by power, the station battery backup supplies a 13.8V signal to the MASTR III Multiple Receiver on the BATT_STDBY line. The M/R Shelf then generates a user-programmable alert tone and sends it on the line out. If the battery standby signal is not connected to the input of the M/R Shelf, the option must be disabled in the receiver personality to prevent alarm tones from being generated.

The repetition rate and on-time rate are programmable through the personality EEPROM. The repetition rate sets the time from the beginning of a tone to the beginning of the next tone, and the on-time rate sets the duration of the tone burst.

SYSTEM INTERFACES

This section contains a description of the interfaces to the Control Section and receiver. Also, interfaces to the GETC shelf, MASTR III Base Station, (Second Receiver application), programming/diagnostics serial ports, and other miscellaneous interconnections are described.

NOTE

All line names are those that are standard to the MASTR III Multiple Receiver. Signal lines whose names have been changed from the MASTR III Base Station will have the former name listed in parenthesis

RECEIVER SYNTHESIZER

SERIAL_CLK - This digital signal provides a clock for loading the Rx Synthesizers. This signal originates at the System Module and is routed by the backplane to the RF Section and the Interface Board.

RXF4/AUX2 - This digital signal provides data for loading the Rx Synthesizers. RXF4/AUX2 originates at the System Module and is routed by the backplane to the RF Section and the Interface Board.

RXF2 - This digital signal provides an enable pulse to the Rx Synthesizers. RXF2 originates at the System Module and is routed by the backplane to the RF Section and the Interface Board.

TXF1, TXF2, RXF1 - These digital signals provide addresses A0, A1, and A2 for the Rx Synthesizers. These signals originate at the System Module and are routed by the backplane to the RF Section and the Interface Board.

INT_OSC - This digital signal is an output from the Interface Board. The Receiver Synthesizers use the signal to select either the internal or the external reference oscillator. A logic high selects the internal oscillator.

GETC INTERFACE

VOL/SQ_LO - This output is the common line for the RCVR_VOL/SQ_HI input. It is grounded in the M/R Shelf.

RCVR_VOL/SQ_HI - This receiver audio output is routed to the GETC for recovery of 9600 bps digital data and recovery of 150 bpd subaudible data.

CAS - The M/R Shelf output is driven to logic high when carrier activity is detected.

RUS_IN - This input signal unmutes the receiver by sending a logic high when the transmission is validated.

CG_MON - In a conventional application, this is an input/output line between the auxilliary receiver GETC and the base station GETC allowing them to communicate their status to each other.

1950_DIS - The 1950 Hz voting tone is muted by a logic high input. The signal originates at the System Module and is routed by the backplane to the RF Section and the Interface Board. Audio is now present on the Line output.

RX_1_MUTE (SYS_RUS_OUT) - The M/R Shelf presents a low (0.3 VDC @ 30 milliamperes) on this open collector output when the audio from the receiver is unmuted.

GETC_RESET - This digital signal is an output from the M/R that controls SOR. A logic low pulse

(10 milliseconds) resets the GETC.

RX_SYNTH_LOCK_DET - Not currently used, awaiting future implementation.

SECOND RECEIVER INTERFACE

CG_MON - In this application, this is an input/output line between the auxilliary receiver and the base station allowing them to communicate their status to each other.

GND - This is the ground supply to the M/R Shelf.

INTRCM_AUDIO - If an on-frequency signal is present, and the receiver is not muted (**RX_1_MUTE** = open collector), de-emphasized audio with no CG present is routed to this output.

RX_MUTE_EXT - When this input is grounded by T/R Shelf or other outside source, receiver is muted.

RX_1_MUTE (SYS_RUS_OUT) - The M/R Shelf presents a low (0.3 VDC @ 30 milliamperes) on this open collector output when audio from the receiver is muted.

MONITOR PANEL

Monitor panel 188D5495G1 is connected to general purpose connector J102/J302 through monitor panel harness 19B803639. This harness routes the following two signals to the monitor panel. It also leaves access to the general purpose connector.

MONITOR_AUD - This line is capable of driving an 8-ohm speaker or a 4-ohm speaker.

+12 Vdc Supplies a +12 Vdc 5% output rated at 350 milliamperes.

MONITOR_GND - This line provides the ground for the speaker.

+5 Vdc Supplies a +5 Vdc 5% output rated at 1000 milliamperes.

PROGRAMMING/DIAGNOSTICS SERIAL PORTS

+5A Vdc Supplies a second +5 Vdc 5% output rated at 40 milliamperes for *analog* circuitry.

The programming/diagnostics RS-232 serial port is used to communicate with a personality programmer, automated test equipment during manufacture, and other system components.

-12 Vdc Supplies a -12 Vdc 5% output rated at 150 milliamperes.

When the Utility Handset is connected, the desired receiver must be selected while depressing a volume button, executing an autobaud sequence. This provides communication from handset to shelf using 300 baud data; otherwise the front data port communicates using 9600 baud data. After using the handset, toggle the RESET switch on the front of the M/R Shelf to reset the serial port to 9600 baud.

-5 Vdc Supplies a -5 Vdc 5% output rated at 40 milliamperes for M/R Shelf operation only.

GENERAL PURPOSE CONNECTOR - This is a multipurpose connector with pins for the audio monitor panel, squelch operated relay (SOR), and programmable TTL input/output.

CONTROLS AND INDICATORS

Controls

RESET The left and right switches reset the respective System Module personality.

SELECT This switch allows the operator to toggle between the left and right system modules for local programming through the Front Programming/Diagnostics Connector or Handset Connector and the rear data ports for remote programming. In the case of just one receiver, the select switch will toggle between local and remote programming.

REAR PROGRAMMING/DIAGNOSTICS CONNECTOR - This port is used for programming the System Module and for metering from a remote location.

SQ DEFEAT This switch forces the receiver to unsquelch.

FRONT PROGRAMMING/DIAGNOSTICS CONNECTOR - This port is used for programming the System Module and for local metering.

CG MONITOR This switch disables the Channel Guard function, overriding any software functions related to Channel Guard.

HANDSET CONNECTOR - This is a connector that allows the user to perform specific functions using the handset. It also allows monitoring of the output signal.

Indicators

STATION POWER SUPPLY

LOC PGM This LED indicates which receiver has been selected for local programming.

Power Supply Inputs

UN SQ This LED indicates that the receiver is unsquelched.

13.8 Vdc (A+) The station power supply generates a nominal 13.8 Vdc @ 33 Amps, which is used by each Power Module to provide the regulated voltages for each receiver. Power is connected at the Power Module Interconnect Board, which supplies power to the Backplane through the Power Module Harness.

CG MONITOR This LED indicates that Channel Guard has been disabled.

Power Supply Module Outputs

POWER This LED indicates that the respective receiver is on.

+13.8 Vdc Supplies a filtered +13.8 Vdc 10% output rated at 1550 milliamperes.

CIRCUIT ANALYSIS

INTERFACE BOARD

Line Interconnect

Audio is sent out of the M/R shelf through the terminal blocks (TB101 and TB301) and RJ14 jacks (J101 and J301) on the interface board. Audio from the M/R Shelf is coupled to the outside through transformers T101 (left receiver) and T301 (right receiver) over signals LINE_A and LINE_B. The line interface connector is intended for a termination impedance of 600 ohms.

Audio Monitor Panel Amplifier

Audio power amplifiers U104 and U304 provide a maximum of 2.25 watts of audio to the MONITOR_AUDIO line. This line is routed to the monitor panel for local monitoring. Resistors R126, R127, R326 and R327 form the gain setting feedback network and capacitors C109 and C309, and resistors R128 and R328 provide compensation for loop stability.

Serial Communications

The M/R shelf may be connected to a PC through the front or left/ right rear panel connectors; J208, J103 and J303 respectively. Connector J207 may be connected to the Utility Handset. Serial TTL data from handset (KEYPAD_SERIAL) is converted to RS-232 levels by comparator U113 and zener diodes D117 and D118 or U313 and zener diodes D317 and D318 depending on which receiver is selected. RS-232 data transmitted from a PC (PC_PGM_RXD) and the level converted data from the handset are switched by either diodes D101 and D103 and resistor R123 or diodes D301 and D303 and resistor R323 to form signal PGM_RXD. This signal is routed to a RS-232 receiver on the System Module where the UART is located. Serial data transmitted by the M/R shelf to the PC through J103 and J303 data ports (PGM_TXD) is RS-232 compatible and requires no processing. Data transmitted by the M/R shelf to the handset is first inverted and level shifted by transistors Q103 or Q303 then connected to the handset by signal DISPLAY_SERIAL.

Flag Status Register

Shift registers U105 and U305 act as a parallel to serial converter that holds the flag status of the 3 RF modules (RX SYN, RXFE, IF). U105 and U305 are controlled respectively by left and right System Modules using RXF1, TXF2, TXF1 (A2, A1, A0), SERIAL_CLK (Clock), RXF2 (Enable), and M3_STATUS.

The System Module first outputs A2, A1, and A0. Then flag bits are loaded into the shift register by setting ENABLE high followed by a low to high to low pulse on CLOCK. The flag bits are then shifted out (with ENABLE low) on M3_STATUS on succeeding CLOCK pulses. Since the register shifts right (LSB first), the first five bits out are don't cares with the fourth bit being FLAG_2 and the eighth bit being FLAG_0.

Output Register

Shift registers U106 and U306 act as a serial to parallel converter that expands the System Module's output bits. U106 and U306 are controlled by the System Modules using RXF1, TXF2, TXF1 (A2, A1, A0), SERIAL_CLK (Clock), RXF2 (Enable), and RXF4/AUX2 (DATA). The System Modules first output A2, A1, and A0. Next, data is presented by the System Modules on the signals DATA_L and DATA_R and is shifted into U106's and U306's buffers on the leading edge of CLOCK. After 8 bits of data have been shifted into each U106's and U306's buffers, ENABLE is driven high and the next CLOCK pulse, the two sets of 8 bits are loaded into U106's and U306's output registers. The bits are shifted out of the System Modules with the MSB first. One set of 8 bits are defined as:

- D7 : NOT USED
- D6 : NOT USED
- D5 : NOT USED
- D4 : NOT USED
- D3 : NOT USED
- D2 : NOT USED
- D1 : NOT USED
- D0 : INT_OSC - input to Receiver Synthesizer. Selects internal or external reference.

Handset Interface

Connector J207 provides an interface for a Utility Handset SPK9024. The Utility Handset not only provides serial communication with the M/R shelf, but also receives audio from the M/R shelf (INTRCM_AUDIO) to its speaker.

Squelch Adjustment

The shelf provides for remote squelch adjustment through the handset or the remote/diagnostic ports via a PC. Signals RCVR_VOL_SQ_HI_L and RCVR_VOL_SQ_HI_R are connected to two voltage dividers formed by U121-R197 and U321-R397. U121 and U321 are digitally programmable by the System Modules using RXF1, TXF2, TXF1 (A2, A1, A0), SERIAL_CLK (Clock), RXF2 (Enable) lines. The System Modules first output A2, A1, and A0. Next, RXF2 is put out to determine the direction of change in the wiper. Every time the clock pulses, the wipers move according to the direction

PARTS LIST

LBI-39112

SYMBOL	PART NO.	DESCRIPTION
R311		
and		
R312	H212CRP210C	Copper Film: 1K Ohms, 1/4 Watt.
R314	H212CRP156C	Copper Film: 560 Ohms, 1/4 Watt.
R315	H212CRP322C	Copper Film: 22K Ohms, 1/4 Watt.
R316	H212CRP368C	Copper Film: 68K Ohms, 1/4 Watt.
R317	H212CRP268C	Copper Film: 6.8K Ohms, 1/4 Watt.
R318	H212CRP422C	Copper Film: 220K Ohms, 1/4 Watt.
R319	H212CRP910C	Copper Film: 10M Ohms, 1/2 Watt.
R320	H212CRP247C	Copper Film: 4.7K Ohms, 1/4 Watt.
R322	H212CRP410C	Copper Film: 100K Ohms, 1/4 Watt.
R323	H212CRP322C	Copper Film: 22K Ohms, 1/4 Watt.
R324	H212CRP247C	Copper Film: 4.7K Ohms, 1/4 Watt.
R325	H212CRP356C	Copper Film: 56K Ohms, 1/4 Watt.
R326	H212CRP118C	Copper Film: 180 Ohms, 1/4 Watt.
R327	H212CRP015C	Copper Film: 15 Ohms, 1/4 Watt.
R328	H212CRP910C	Copper Film: 10M Ohms, 1/2 Watt.
R329	19A700113P162	Composition: 1 Ohm, 1/2 Watt.
R330	H212CRP410C	Copper Film: 100K Ohms, 1/4 Watt.
R331	H212CRP310C	Copper Film: 10K Ohms 1/4 Watt.
R332	H212CRP315C	Copper Film: 15K Ohms, 1/4 Watt.
R333	H212CRP510C	Copper Film: 1.0M Ohms, 1/4 Watt.
R334	H212CRP220C	Copper Film: 2.0K Ohms, 1/4 Watt.
R344		
thru		
R349	H212CRP210C	Copper Film: 1K Ohms, 1/4 Watt.
R351	H212CRP191C	Copper Film: AX, 910 Ohms, 1/4 Watt.
R352	H212CRP110C	Copper Film: 100 Ohms, 1/4 Watt.
R353	H212CRP191C	Copper Film: AX, 910 Ohms, 1/4 Watt.
R358	H212CRP147C	Copper Film: 470 Ohms, 1/4 Watt.
R375		
thru		
R378	H212CRP210C	Copper Film: 1K Ohms, 1/4 Watt.
R379		
thru		
R382	H212CRP147C	Copper Film: 470 Ohms, 1/4 Watt.
R385	H212CRP147C	Copper Film: 470 Ohms, 1/4 Watt.
R386	H212CRP210C	Copper Film: 1K Ohms, 1/4 Watt.
R387	H212CRP322C	Copper Film: 22K Ohms, 1/4 Watt.
R388	H212CRP327C	Copper Film: 27K Ohms, 1/4 Watt.
R389	H212CRP147C	Copper Film: 470 Ohms, 1/4 Watt.
R391	H212CRP247C	Copper Film: 4.7K Ohms, 1/4 Watt.
R392	H212CRP356C	Copper Film: 56K Ohms, 1/4 Watt.
R394	H212CRP356C	Copper Film: 56K Ohms, 1/4 Watt.
R397	H212CRP247C	Copper Film: 4.7K Ohms, 1/4 Watt.
		-----SWITCHES-----
S101	RMF356100/5	Toggle
S201	RMF356100/5	Toggle
S301	RMF356100/5	Toggle
		-----TRANSFORMERS-----
T101	344A3966P2	Telephone
T301	344A3966P2	Telephone
		-----TERMINAL BOARDS-----
TB101	NEM17301/02	Term Bd.
TB301	NEM17301/02	Term Bd.
		-----INTEGRATED CIRCUITS-----
U104	19A701830P1	Linear Audio Amplifier.
U105	19A703987P21	8-Bit, Bi-directional Universal Shift Register with parallel I/O (74HC299)
U106	19A703987P24	8-Bit, Shift Register, Tri-State Outputs (74HC595)
U107	19A704445P1	1-of-8 Decoder/De-Multiplexer (74HC138).

SYMBOL	PART NO.	DESCRIPTION
U109	19A703483P11	Quad 2-input OR gate (74HC32)
U113	19A701789P1	Quad Operational Amplifier (LM324).
U114	19A116297P4	Dual Operational Amplifier (MC1458P).
U121	19A705180P2	Potentiometer, Digitally Controlled (X9103).
U201	19A700037P301	Quad 2-Input Positive -NAND Gate (74LS00).
U202	19A700037P337	Dual J-K Flip-Flop with Preset and Clear (74LS76A)
U204		
and		
U205	RYTUA10104/1	Quad Single-Pole-Single-throw analog switch (DG445)
U206	19A700029P38	Triple 2-channel Multiplexer (4053B)
U304	19A701830P1	Linear Audio Amplifier.
U305	19A703987P21	8-Bit, Bi-directional Universal Shift Register with parallel I/O (74HC299)
U306	19A703987P24	8-Bit, Shift Register, Tri-State Outputs (74HC595)
U307	19A704445P1	1-of-8 Decoder/De-Multiplexer (74HC138).
U309	19A703483P11	Quad 2-input OR gate (74HC32)
U313	19A701789P1	Quad Operational Amplifier (LM324).
U314	19A116297P4	Dual Operational Amplifier (MC1458P).
U315	19A700037P307	Dual 2-Input, Positive AND gate (74LS08).
U321	19A705180P2	Potentiometer, Digitally Controlled (X9103).
U403	19A700037P307	Dual 2-Input, Positive AND gate (74LS08).
		-----ZENER DODES-----
VR117		
and		
VR118	19A700025P9	Zener: 7.7-8.7V
VR317		
and		
VR318	19A700025P9	Zener: 7.7-8.7V
		-----RELAY SOCKETS-----
XK101	19A700156P9	Int Ckt
XK301	19A700156P9	Int Ckt
		-----MISCELLANEOUS-----
3	19A702917P7	Heat Sink (transistor)
4	19A702364P308	Screw, Machine, Pan Head, Steel.
5	19A705469P1	Plate, Insl.
6	19A700032P5	Lockwasher, internal tooth: No. 3MM.
7	19A700034P4	Nut, Hex, Steel.
10	SBM175030	Nut, Press

PARTS LIST
MASTR III MULTIPLE RECEIVER
SHELF ASSEMBLY
188D5452 G1

SYMBOL	PART NUMBER	DESCRIPTION
		----- ASSEMBLIES -----
A1	188D5139G1	Multiple Receiver Interface Board
A2	188D5329G1	Backplane
A3 and A4	19C852485G1	MASTR III Multiple Receiver Shelf Power Module Interconnect Board
		----- JACKS -----
J1 and J2	19A115938P13	Connector, Receptacle
		----- CABLES -----
W1	19B803412P1	MASTR III Receiver Shelf Power Harness
		----- MISCELLANEOUS -----
2	188D5316P1	Shelf
3	188D5052P1	Cover
4	188D5052P2	Cover
5	19A702381P506	Screw, thread forming: TORX, No. M3.5-.6 x 6.
6	19A702364P306	Screw, Machine
7	19A700032P5	Lockwasher, internal tooth: No. 3MM.
8	19A701863P20	Clamp; sim to Wickesser 1/2-6.
9	19A702364P510	Screw, machine, pan head, TORX DRIVE: M4.
10	19A701312P6	Flatwasher: 1.7 -1.85 ID.

PARTS LIST
BACKPLANE BOARD
188D5329G1

SYMBOL	PART NUMBER	DESCRIPTION
J11 thru J14	19B801587P8	96 Position Flow Solder Receptacle with Board Lock Feature.
J15	RPT403405/012	12 Pin Printed Wire Board Mounted Connector
J21 thru J24	19B801587P8	96 Position Flow Solder Receptacle with Board Lock Feature.
J25	RPT403405/012	12 Pin Printed Wire Board Mounted Connector
P11 and P12	19A704852P40	14 Circuit Connector, Printed Wire Board, Two Part, Gold Over Brass.
P13	19A704852P36	10 Circuit Connector, Printed Wire Board, Two Part, Gold Over Brass.
P14	19A704852P31	5 Circuit Connector, Printed Wire Board, Two Part, Gold Over Brass.
P21 and P22	19A704852P40	14 Circuit Connector, Printed Wire Board, Two Part, Gold Over Brass.
P23	19A704852P36	10 Circuit Connector, Printed Wire Board, Two Part, Gold Over Brass.
P24	19A704852P31	5 Circuit Connector, Printed Wire Board, Two Part, Gold Over Brass.

PARTS LIST
POWER MODULE INTERCONNECT BOARD
19C852485G1

SYMBOL	PART NUMBER	DESCRIPTION
J1	19A801587P8	96 Position Flow Solder Receptacle with Board Lock Feature.
J2	RPT403405/012	12 Pin Printed Wire Board Mounted Connector
4	SBM175030	Nut, Press

MONITOR PANEL
188D5495G1

SYMBOL	PART NUMBER	DESCRIPTION
1	19B803633P1	Chassis.
2	19B803634P1	Harness.
J1 Thru J10		Plug: similar to AMP Cat No. 172157-1
SPK1		Loudspeaker: 2 Watt, 8 Ohm. Similar Foster Electronic C072A01A0000.
R1		Variable: 25 Ohm, 25 Watt. Similar to Ohmite Model "H" Cat. No. RHS25R.
3	19A704977P1	Switch.
5	19B801706P1	Knob, Push On.
6	19A714125P3	Nut, Machine Screw, Hex, Steel.
7	N402P37B6	Washer, Panel., Regular, Steel.
8	N404P13B6	Washer, Lock, Internal Teeth.

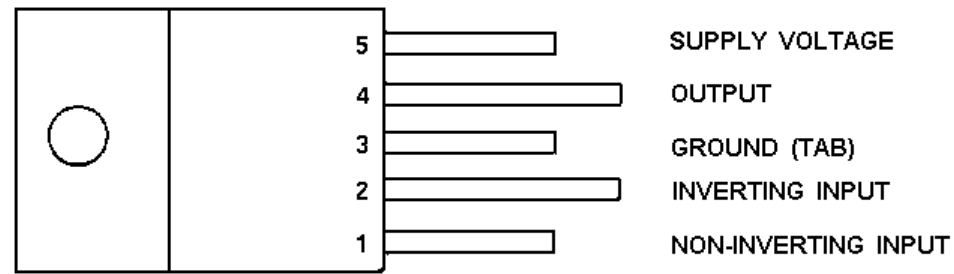

PIN IDENTIFICATION

**Linear Audio Amplifier U104, U304
19A701830P1**

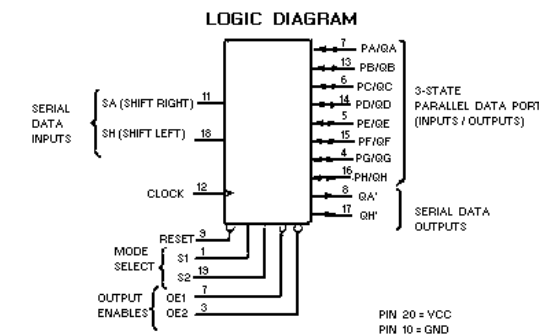
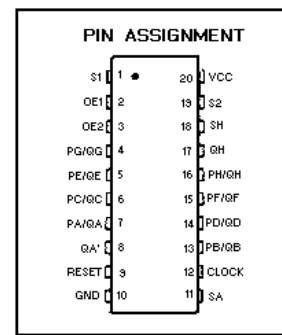

**8-Bit, Bi-directional Universal Shift Register with parallel I/O U105, U305
19A703987P21 (74HC299)**

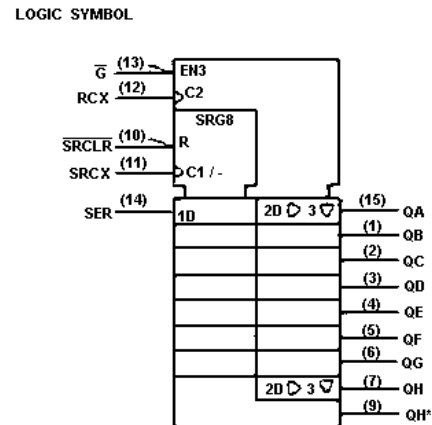
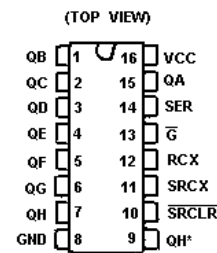

**8-Bit, Shift Register, Tri-State Outputs U106, U306
19A703987P24 (74HC595)**

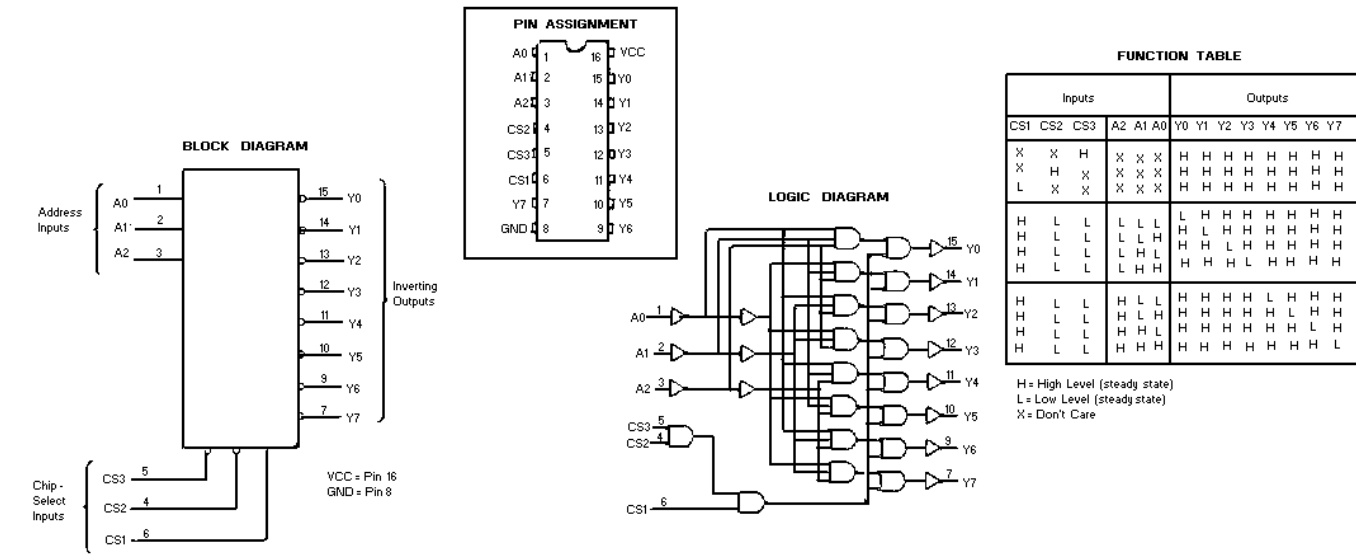

**1-of-8 Decoder/De-Multiplexer U107, U307
19A704445P1 (74HC138)**

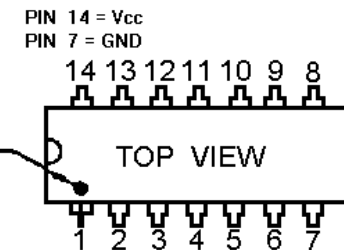
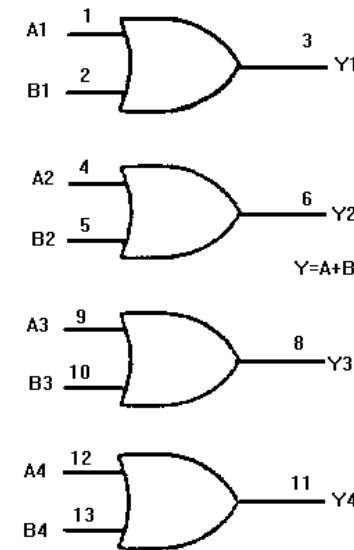

**Quad 2-input OR gate U109, U309
19A703483P11 (74HC32)**

**Quad Operational Amplifier U113, U313
19A701789P1 (LM324)**

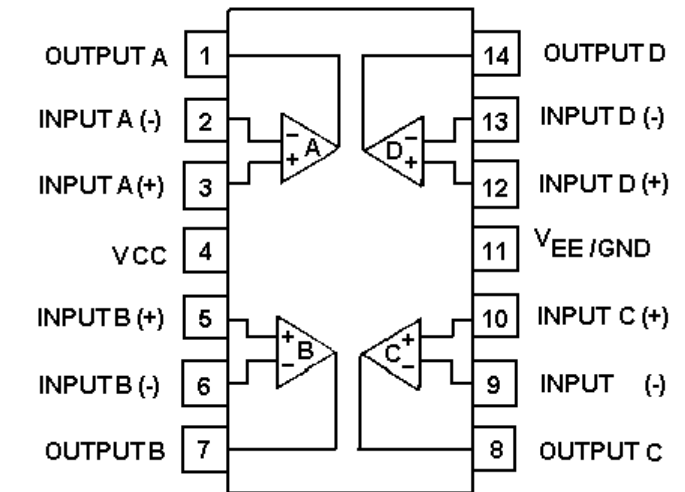

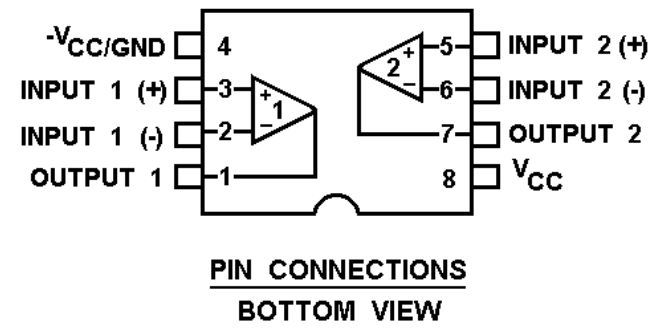

**Dual Operational Amplifier U114, U314
19A116297P4 (MC1458P)**

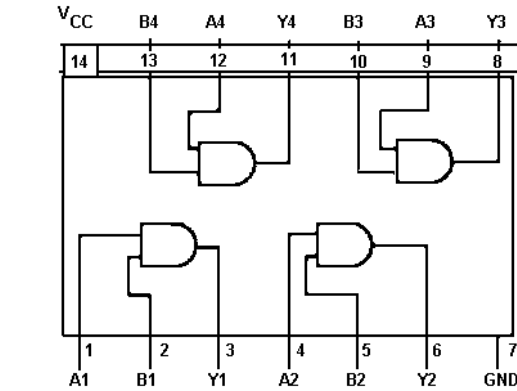

**Dual 2-Input, Positive AND gate U315, U403
19A700037P307 (74LS08)**

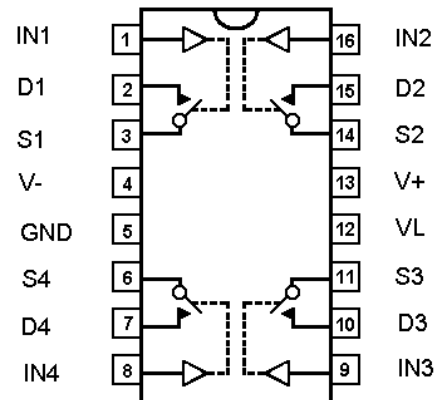

NAME	FUNCTION
IN1 - IN4	Logic Control inputs
D1 - D4	Drain Outputs
S1 - S4	Source Outputs
V-	Negative Supply Voltage Input
GND	Ground
VL	Logic Supply Voltage input
V+	Positive Supply Voltage input

FOUR SPST SWITCHES PER PACKAGE

LOGIC	SWITCH
0	OFF
1	ON

LOGIC "0" ≤ 0.8V
LOGIC "1" ≥ 2.4V

**QUAD SINGLE-POLE-SINGLE-THROW
ANALOG SWITCH U204, U205
RYTUA10104/1 (DG445DJ)**

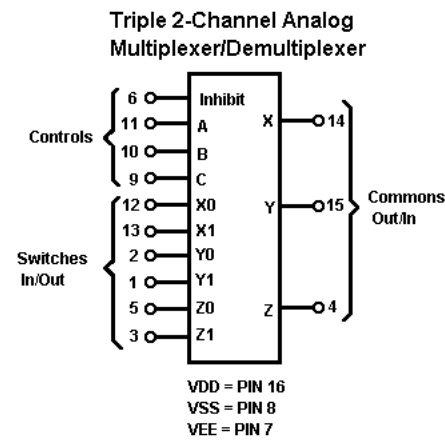

**Triple 2-channel Multiplexer U206
19A700029P38 (4053B)**

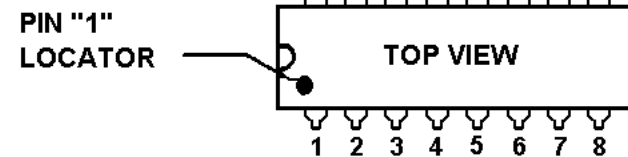

PIN CONFIGURATION

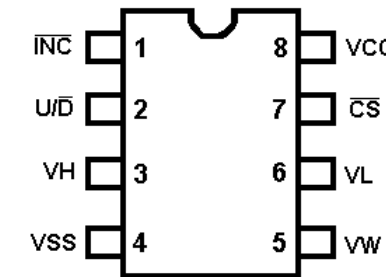

PIN NAMES

VH	HIGH TERMINAL OF POT
VW	WIPER TERMINAL OF POT
VL	LOW TERMINAL OF POT
VSS	GROUND
VCC	SYSTEM POWER
U/D	UP / DOWN CONTROL
INC	WIPER MOVEMENT CONTROL
CS	CHIP SELECT

FUNCTIONAL DIAGRAM

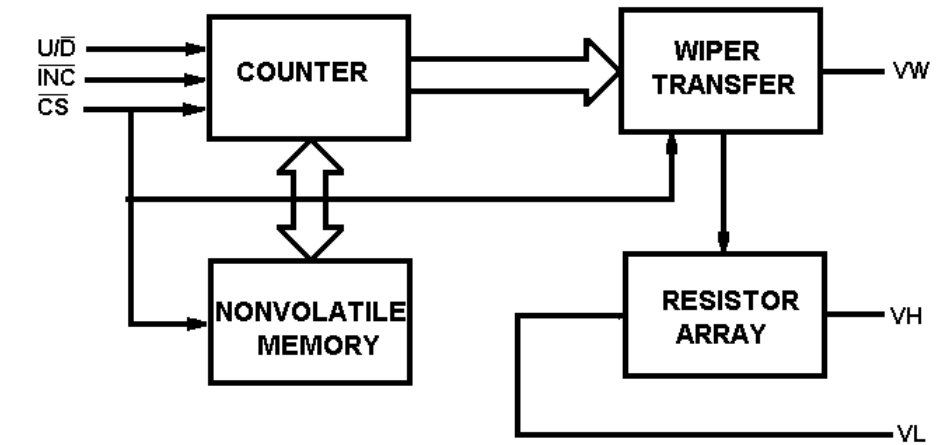

**Potentiometer, Digitally Controlled U121, U321
19A705180P2 (X9103)**

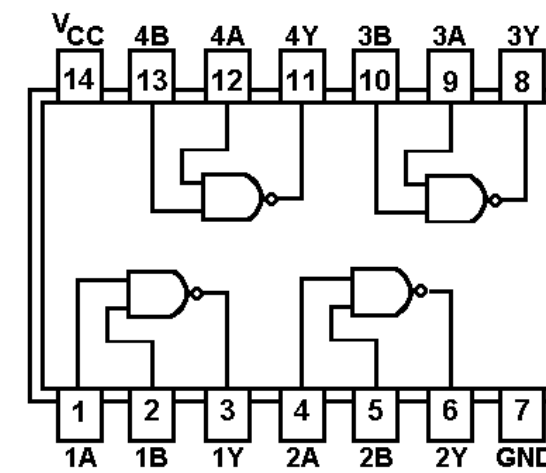

**Quad 2-Input Positive NAND Gate U201
19A700037P301 (74LS00)**

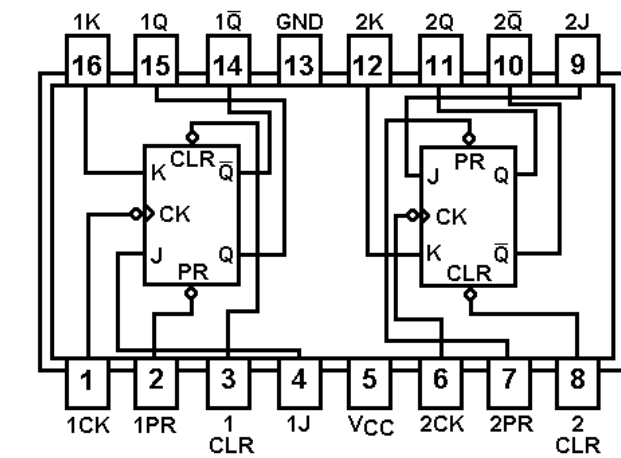

**Dual J-K Flip-Flop with Preset and Clear U202
19A700037P337 (74LS76A)**

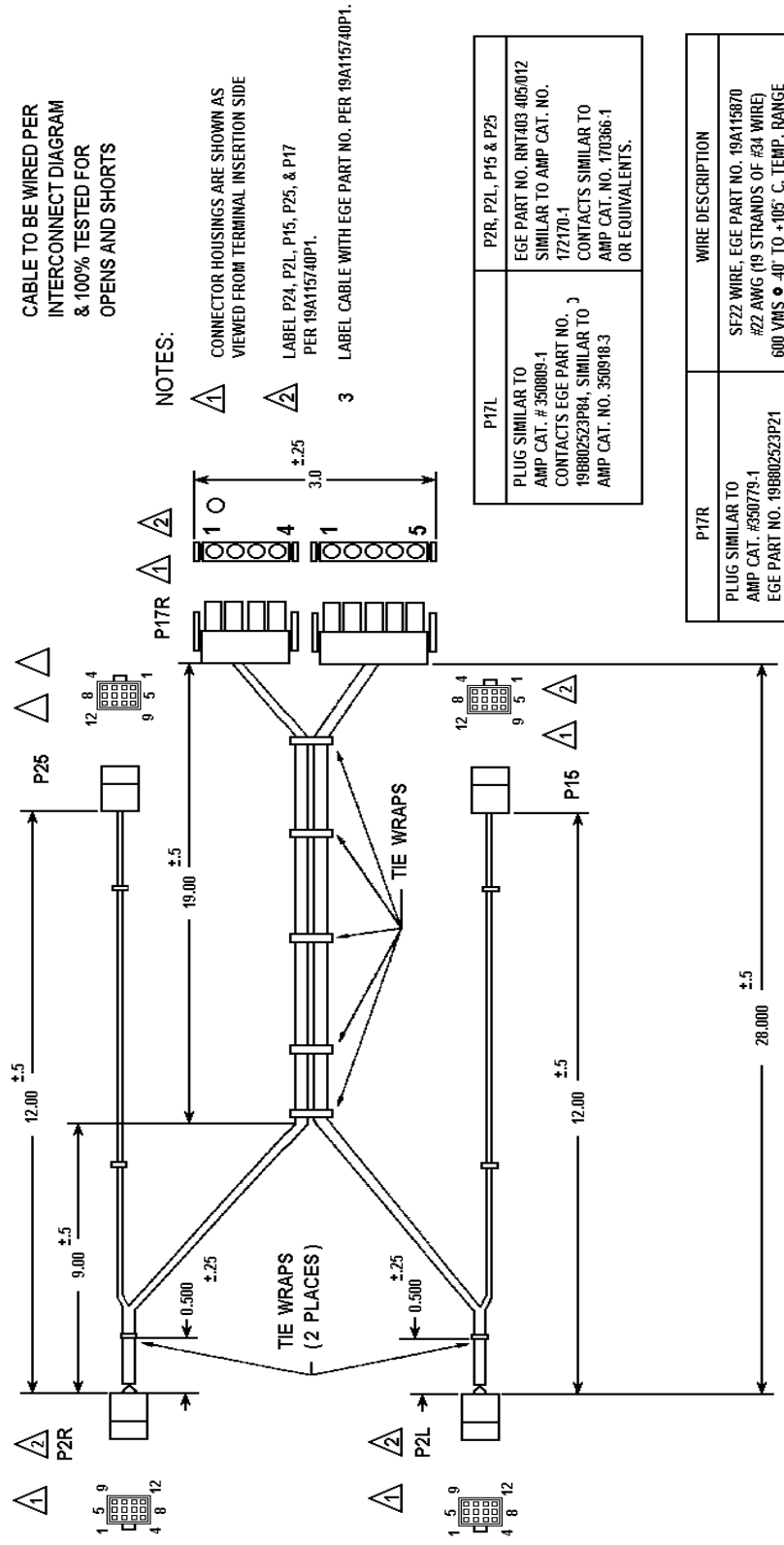

CABLE TO BE WIRED PER INTERCONNECT DIAGRAM & 100% TESTED FOR OPENS AND SHORTS

NOTES:

- 1 CONNECTOR HOUSINGS ARE SHOWN AS VIEWED FROM TERMINAL INSERTION SIDE
- 2 LABEL P24, P2L, P15, P25, & P17 PER 19A115740P1.
- 3 LABEL CABLE WITH EGE PART NO. PER 19A115740P1.

P17L	P2R, P2L, P15 & P25
PLUG SIMILAR TO AMP CAT. # 350009-1	EGE PART NO. RNT403 405012 SIMILAR TO AMP CAT. NO. 172170-1
19B802523P84, SIMILAR TO AMP CAT. NO. 350918-3	CONTACTS SIMILAR TO AMP CAT. NO. 170566-1 OR EQUIVALENTS.

WIRE DESCRIPTION	
P17R	SF22 WIRE, EGE PART NO. 19A115670 #22 AWG (19 STRANDS OF #34 WIRE) 600 VMS • 40" TO +105" C. TEMP. RANGE
P17L	V18 WIRE, EGE PART NO. 19A116889 #18 AWG (16 STRANDS OF .010 DIA. WIRE) 600 VMS • 40" TO +105" C. TEMP. RANGE UL 1015

UNLESS OTHERWISE SPECIFIED ALL WIRES SF22

MASTR III Multiple Receiver Shelf Power Harness 19B803412P1

(19B803412, Sheet 1, Rev.2)

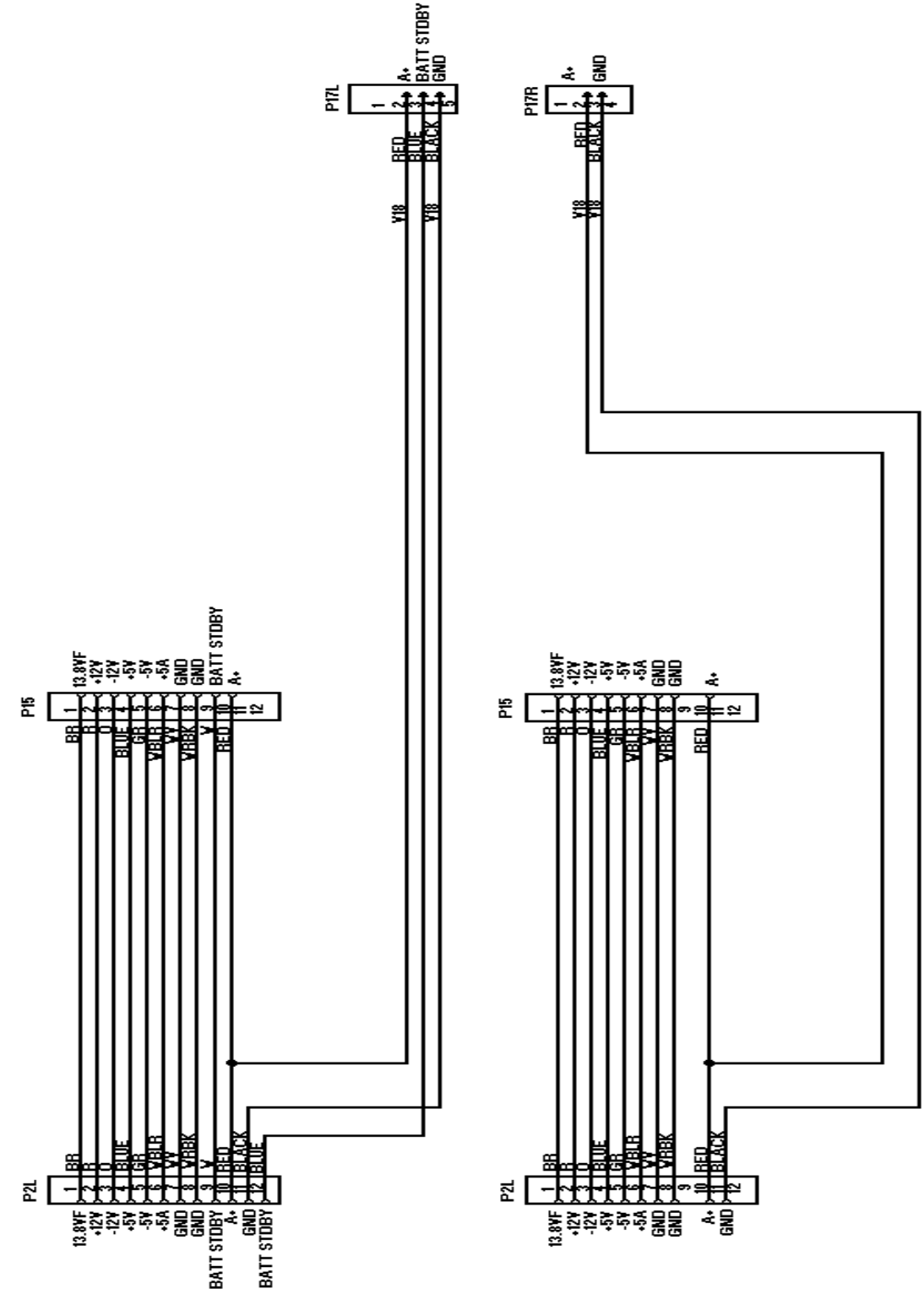

(19B803412, Sheet 2, Rev. 2)

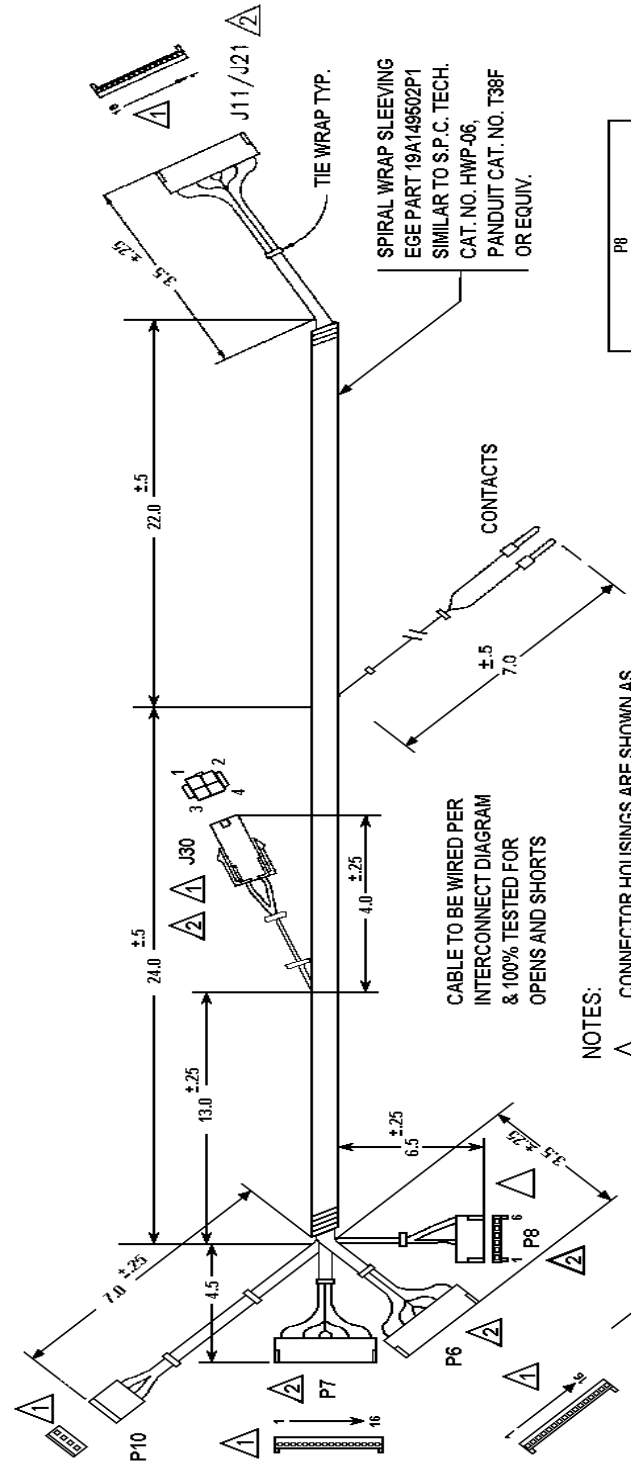

SPIRAL WRAP SLEEVING
EGE PART 19A149602P1
SIMILAR TO S.P.C. TECH.
CAT. NO. HWP-06,
PANDUIT CAT. NO. T38F
OR EQUIV.

CABLE TO BE WIRED PER
INTERCONNECT DIAGRAM
& 100% TESTED FOR
OPENS AND SHORTS

NOTES:
1 CONNECTOR HOUSINGS ARE SHOWN AS
VIEWED FROM TERMINAL INSERTION SIDE

2 LABEL J2, P6, P8, P30, J11/J21 AND P7 PER 19A115740P1.

3 LABEL CABLE WITH EGE PART NO. PER 19A115740P1.

P8
EGE PART NO. 19A700041P32
SIMILAR TO MOLEX CAT. NO.
22-01-2065
CONTACTS EGE PART NO.
19A704779P26, SIMILAR TO
MOLEX CAT. NO. 08-55-0101
OR EQUIVALENTS.

J11/J21	P6 & P7	P10	CONTACTS	WIRE DESCRIPTION	J30
EGE PART NO. 19A700041P40 SIMILAR TO MOLEX CAT. NO. 22-01-2185 CONTACTS EGE PART NO. 19A704779P26, SIMILAR TO MOLEX CAT. NO. 08-55-0101 OR EQUIVALENTS.	EGE PART NO. 19A700041P42 SIMILAR TO MOLEX CAT. NO. 22-01-2185 CONTACTS EGE PART NO. 19A704779P26, SIMILAR TO MOLEX CAT. NO. 08-55-0101 OR EQUIVALENTS.	EGE PART NO. 19A116659P17 SIMILAR TO MOLEX CAT. NO. 09-50-3041 CONTACTS EGE PART NO. 19A116781P3, SIMILAR TO MOLEX CAT. NO. 08-50-0105 OR EQUIVALENTS.	EGE PART NO. 19B80252P64 SIMILAR TO AMP CAT. NO. 300918-3, OR EQUIV.	SF24 WIRE, EGE PART NO. 19A115871 #24 AWG (19 STRANDS OF #26 WIRE) 600 VRMS • -25 TO +85° C. TEMP RANGE V16 WIRE, EGE PART NO. 19A118850 #16 AWG (26 STRANDS OF .100 DIA. WIRE) 600 VRMS • -40 TO +105° C. TEMP RANGE UL 1015	EGE PART NO. 19B801802P40 SIMILAR TO AMP CAT. NO. 172158-1 CONTACTS EGE PART NO. 19B802802P4, SIMILAR TO AMP CAT. NO. 170366-3 OR EQUIVALENTS.

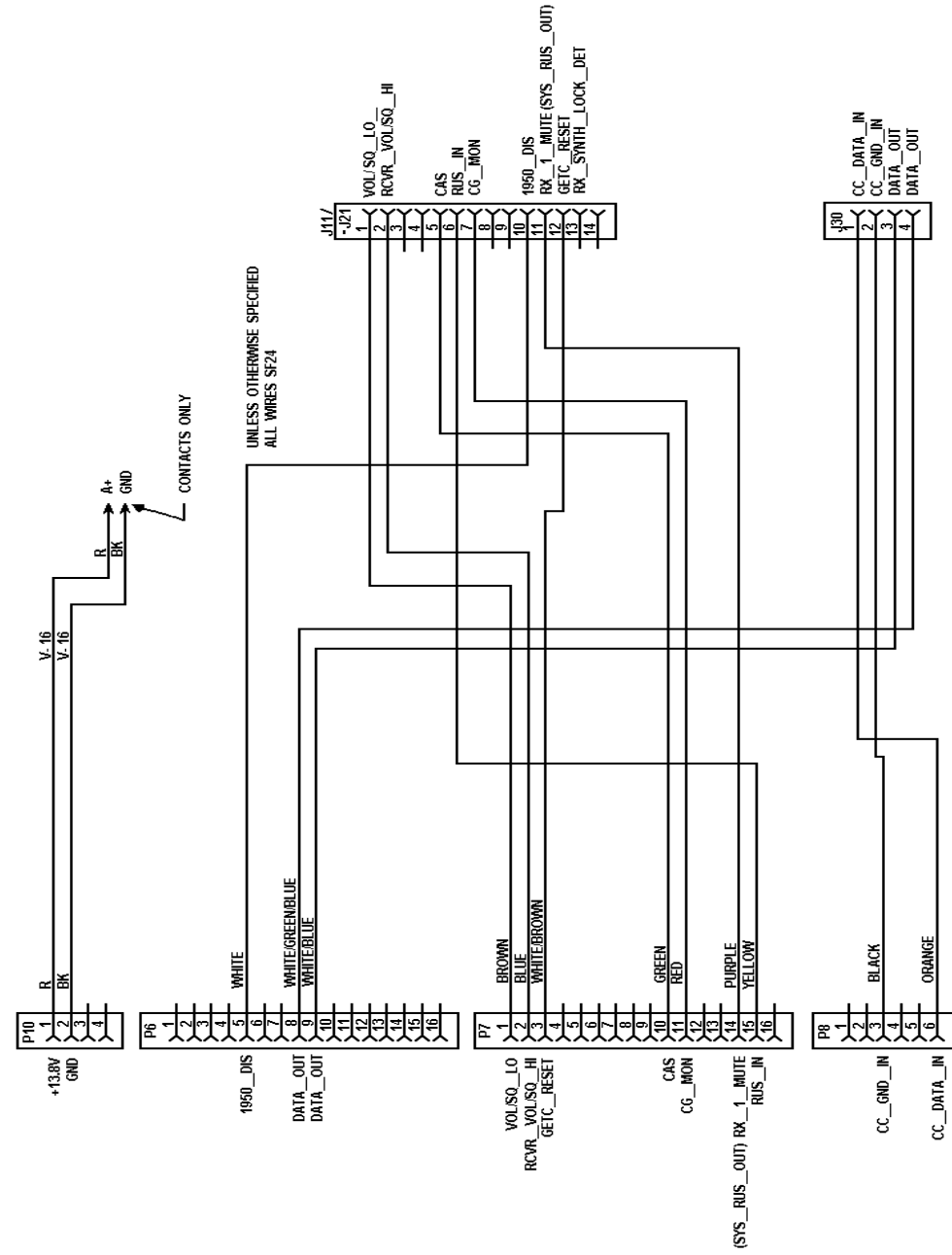

MASTR III Auxiliary Receiver
GETC Harness
19B803411P1

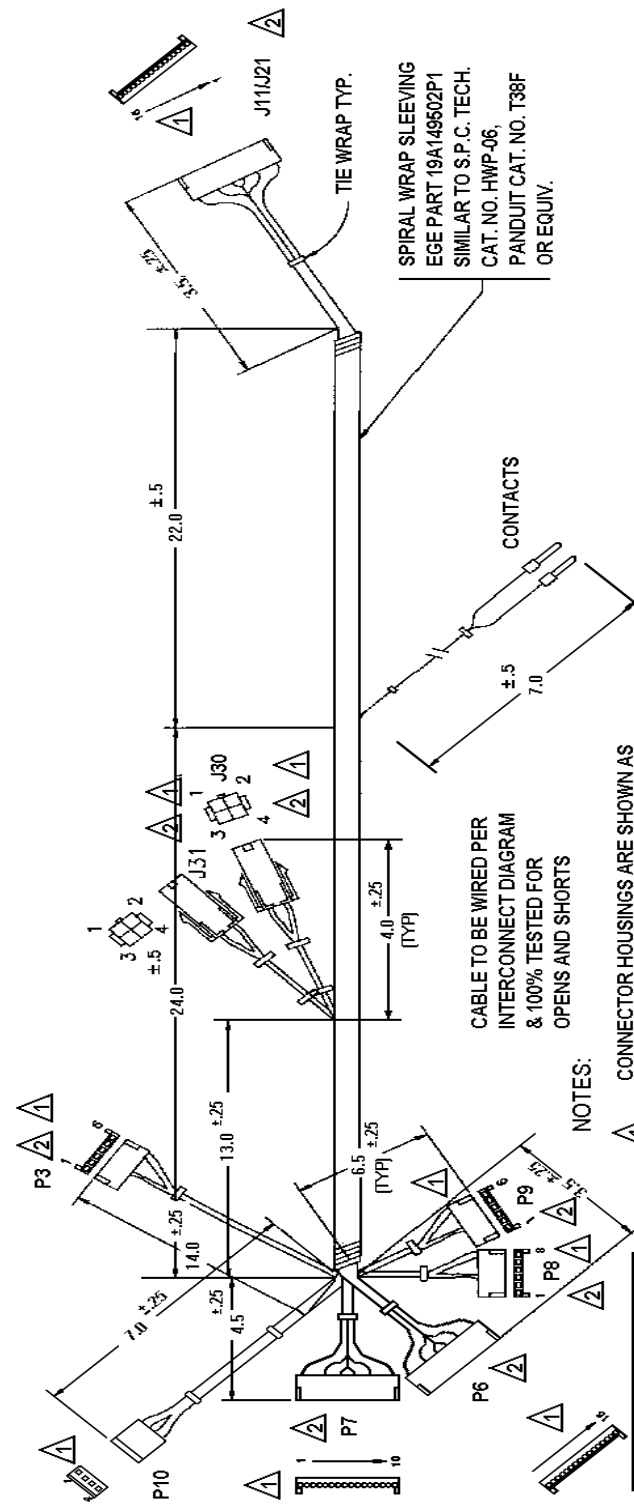

NOTES:

- CONNECTOR HOUSINGS ARE SHOWN AS VIEWED FROM TERMINAL INSERTION SIDE
- LABEL J2, P6, P8, J30, J31, P31, J11J21, P3, AND P7 PER 19A115740P1.
- LABEL CABLE WITH EGE PART NO. PER 19A115740P1.

J11J21	P6 & P7	P10	CONTACTS	WIRE DESCRIPTION	J30 & J31
EGE PART NO. 19A700041P32 SIMILAR TO MOLEX CAT. NO. 22-01-2065 CONTACTS EGE PART NO. 19A70079P26, SIMILAR TO MOLEX CAT. NO. 08-55-0101 OR EQUIVALENTS.	EGE PART NO. 19A700041P42 SIMILAR TO MOLEX CAT. NO. 22-01-2165 CONTACTS EGE PART NO. 19A70079P26, SIMILAR TO MOLEX CAT. NO. 08-55-0101 OR EQUIVALENTS.	EGE PART NO. 19A116650P17 SIMILAR TO MOLEX CAT. NO. 09-50-3041 CONTACTS EGE PART NO. 19A116781P3, SIMILAR TO MOLEX CAT. NO. 08-50-0105 OR EQUIVALENTS.	EGE PART NO. 19880252P64 SIMILAR TO AMP CAT. NO. 350918-3, OR EQUIV.	SF24 WIRE, EGE PART NO. 19A115871 #24 AWG (19 STRANDS OF #36 WIRE) 600 VRMS • 25 TO +85° C. TEMP RANGE V16 WIRE, EGE PART NO. 19A116850 #16 AWG (26 STRANDS OF #10 DIA. WIRE) 600 VRMS • 40 TO +105° C. TEMP RANGE UL1015	EGE PART NO. 198801802P40 0 SIMILAR TO AMP CAT. NO. 172159-1 CONTACTS EGE PART NO. 19880202P4, SIMILAR TO AMP CAT. NO. 170366-3 OR EQUIVALENTS.

**MASTR III Multiple Receiver
GETC Harness, RS-232
19B803411P2**

(19B803411, Sheet 3, Rev. 3A)

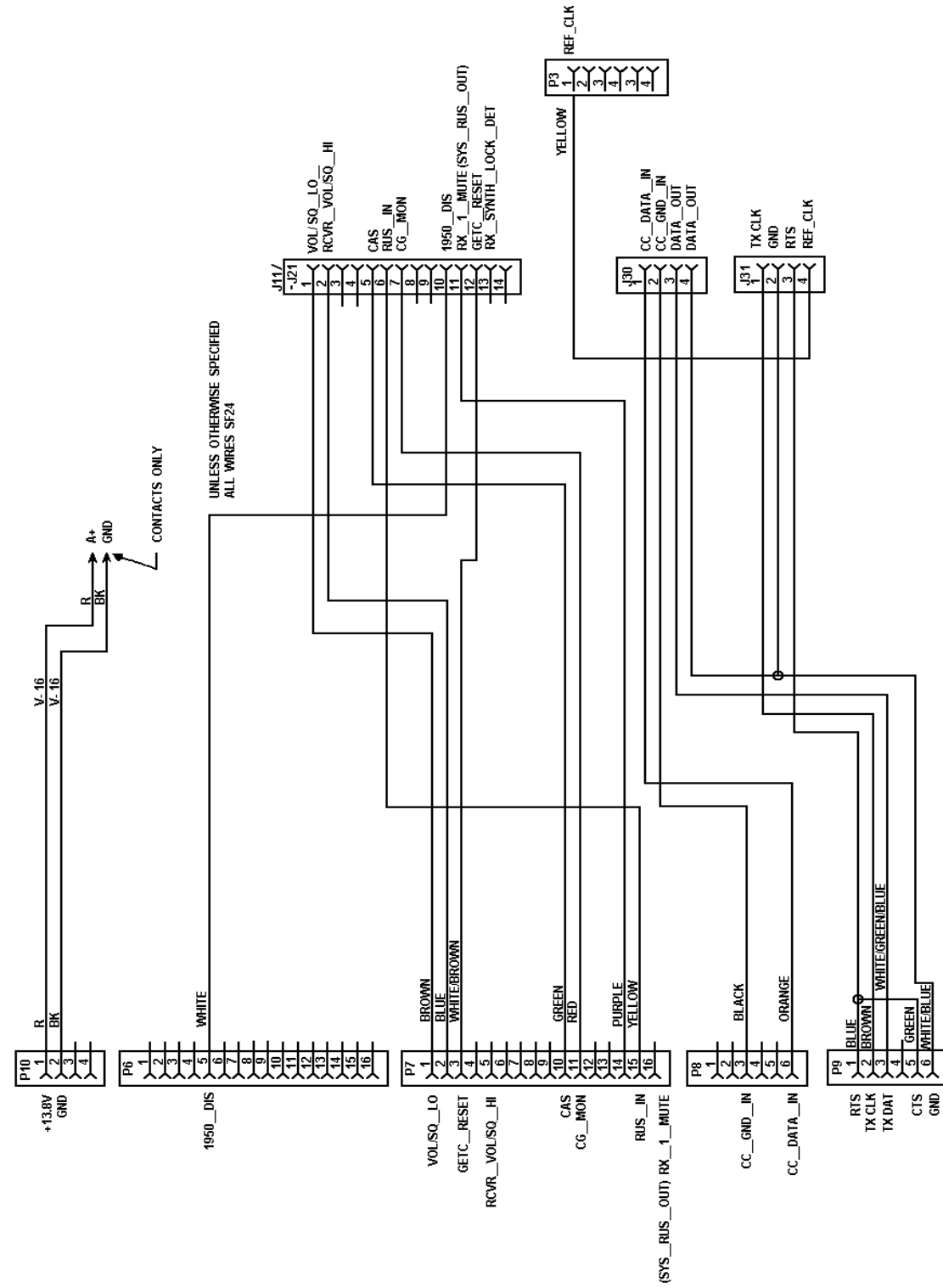

(19B803411, Sheet 4, Rev. 3A)

NOTES:

- △ CONNECTOR HOUSINGS ARE SHOWN AS VIEWED FROM TERMINAL INSERTION SIDE
- △ LABEL P101, P301, AND P1 PER 19A115740P1
- 3 LABEL CABLE WITH EGE PART NO. PER 19A115740P1
- 4 CABLE TO BE WIRED PER INTERCONNECT DIAGRAM & 100% TESTED FOR OPENS AND SHORTS

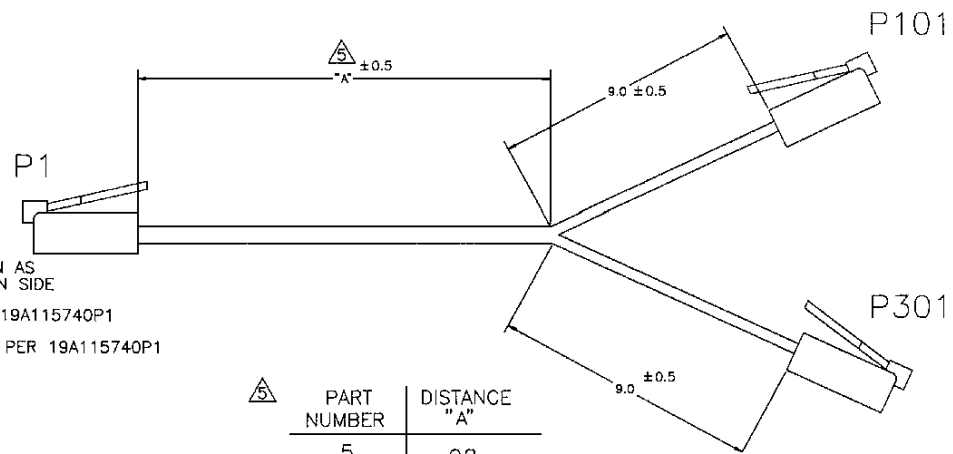

PART NUMBER	DISTANCE "A"
5	92
4	80
3	68
2	56
1	44

P101, P301, & P1	WIRE DESCRIPTION
SIMILAR TO STEWART STAMPING # 937-SP-3066R-SL (MODULAR PLUG RJ11) OR EQUIVALENTS	USE C & M PART NUMBER 19523 WIRE OR EQUIVALENTS

(19B803900, Sheet 1, Rev. 2)

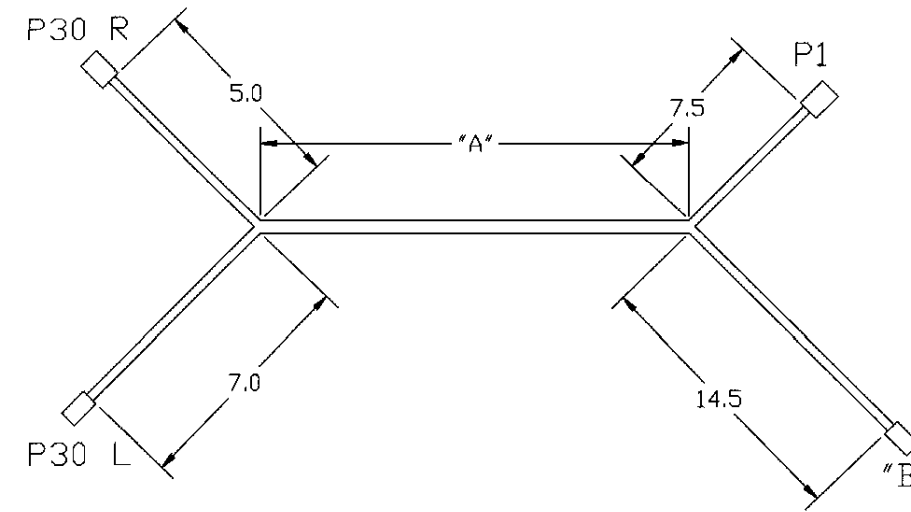

PART NO.	DISTANCE "A"	CONNECTOR "B"
1	14.0 IN.	P7
2	26.0 IN.	P8
3	38.5 IN.	P9
4	51.0 IN.	P10
5	63.0 IN.	P11

P30 L & P30 R	P1	B	WIRE DESCRIPTION
HOUSING EGE PART NO. 19801802P30 SIMILAR TO AMP PART NO. 172167-1 CONTACT (4) #24 EGE PART NO. 19801802P11 SIMILAR TO AMP PART NO. 170364-3 (MALE) OR EQUIVALENTS	SIMILAR TO STEWART STAMPING 937-SP-3066R-SL (MODULAR RJ11 PLUG) OR EQUIVALENT.	HOUSING EGE PART NO. 19A700041P29 SIMILAR TO MOLEX CAT. NO. 22012035 CONTACT (3) #24 EGE PART NO. 19A704779P25, SIMILAR TO MOLEX CAT. NO. 68550102 OR EQUIVALENTS	USE C & M PN N9523 CABLING OR EQUIVALENT

(19B803899, Sheet 1, Rev. 4)

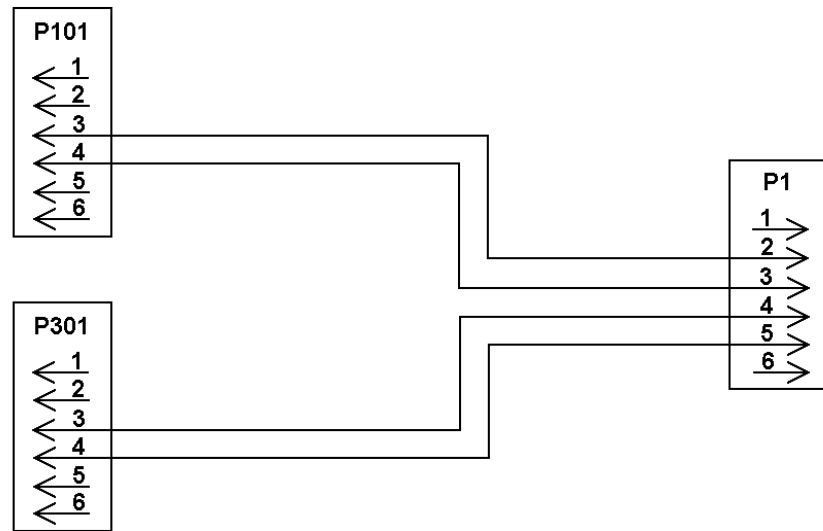

Line - Out Cable
19B803900P1-P5

(19B803900, Sheet 2, Rev. 2)

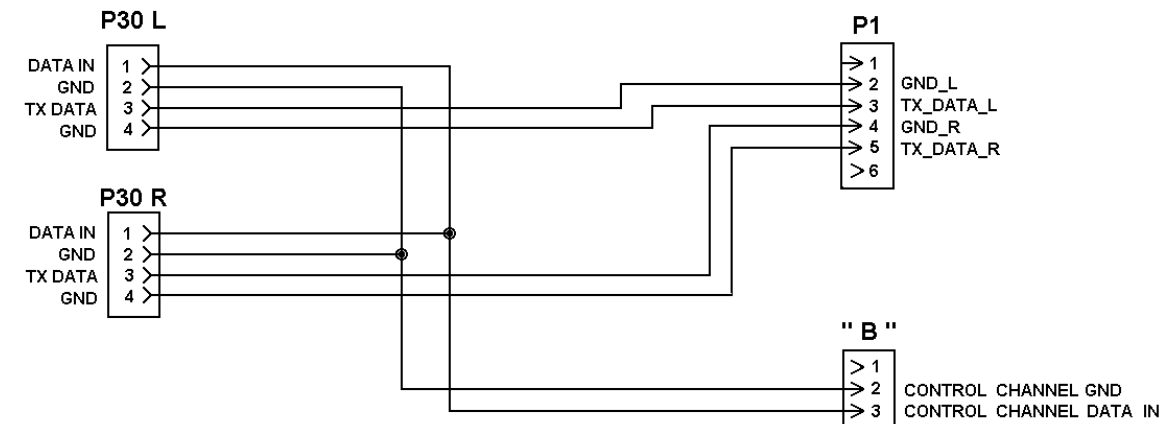

Data Cable
19B803899P1-P5

(19B803899, Sheet 2, Rev. 4)

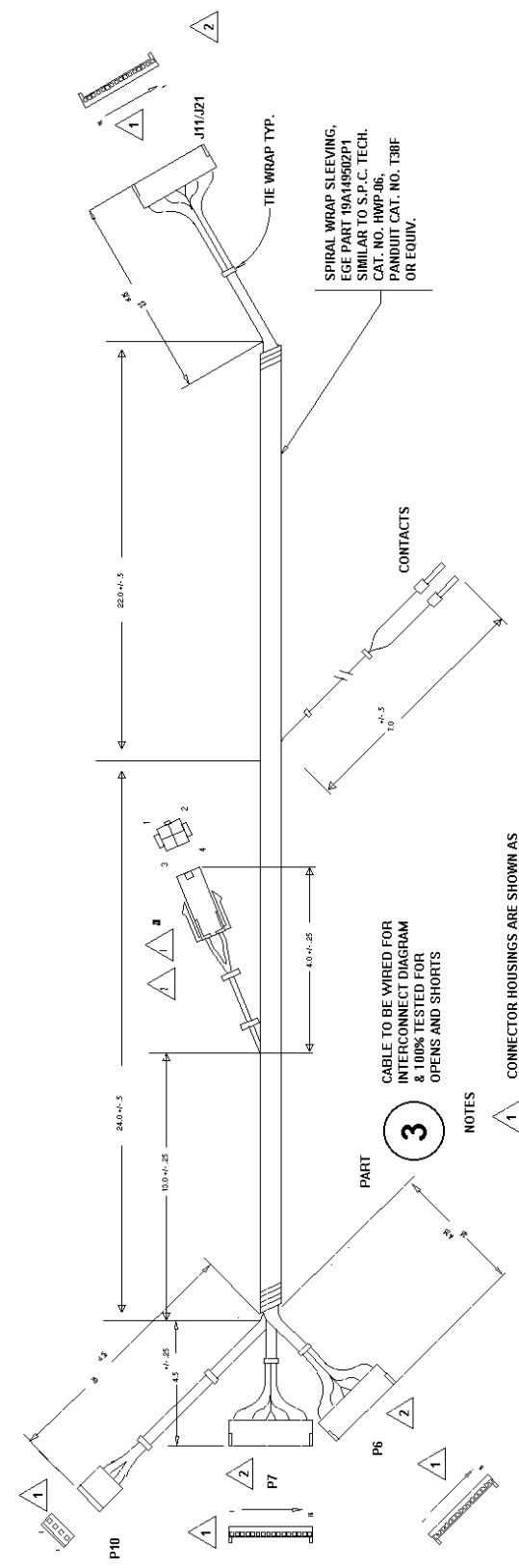

CABLE TO BE WIRED FOR INTERCONNECT DIAGRAM & 100% TESTED FOR OPENS AND SHORTS

PART 3

NOTES

- 1 CONNECTOR HOUSINGS ARE SHOWN AS VIEWED FROM TERMINAL INSERTION SIDE
- 2 LABEL J2, P6, P30, J11/J21 AND P7 PER 19A115740P1
- 3 LABEL CABLE WITH EDGE PART NO. PER 19A115740P1

J11/J21	P6 & P7	P30	CONTACTS	WIRE DESCRIPTION	J30
EDGE PART NO. 19A115740P1 SIMILAR TO MOLEX CAT. NO. 22-01-1335 CONTACTS EDGE PART NO. 19A115740P1 MOLEX CAT. NO. 0975-001 OR EQUIVALENTS	EDGE PART NO. 19A115740P1 SIMILAR TO MOLEX CAT. NO. 22-01-1335 CONTACTS EDGE PART NO. 19A115740P1 MOLEX CAT. NO. 0975-001 OR EQUIVALENTS	EDGE PART NO. 19B0523P4 SIMILAR TO AMP CAT. NO. 350B15-010 CONTACTS EDGE PART NO. 19B0523P4 OR EQUIVALENTS	CONTACTS	SF24 WIRE, EDGE PART NO. 19A115740P1 #14 AWG (8 STRANDED OF #14 WIRE) 600 VMS @ -55 TO +85 C. TEMP RANGE VIA WIRE, EDGE PART NO. 19A115740P1 #14 AWG (8 STRANDED OF #14 WIRE) 600 VMS @ -40 TO +105 C. TEMP RANGE UL145	EDGE PART NO. 19B0523P4 SIMILAR TO AMP CAT. NO. 350B15-010 CONTACTS EDGE PART NO. 19B0523P4 AMP CAT. NO. 350B15-010 OR EQUIVALENTS

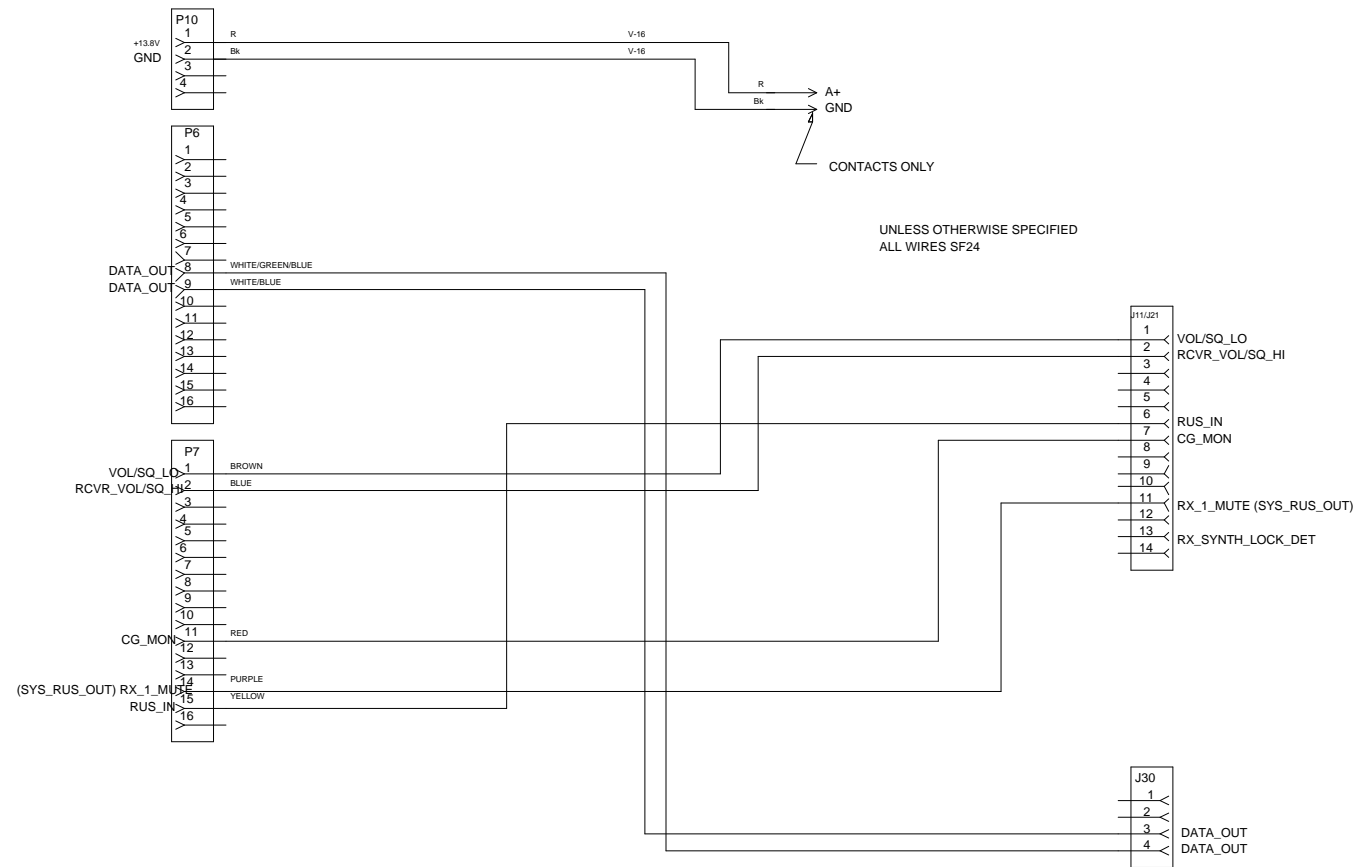

UNLESS OTHERWISE SPECIFIED ALL WIRES SF24

**MASTR III Multiple Receiver
GETC Harness, Voice Guard
19B803411P3**
(19B803411, Sh. 6, Rev. 3A)

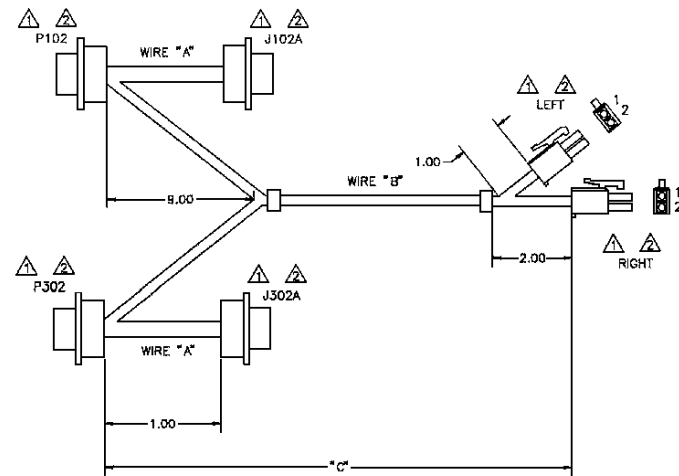

PART ① CABLE TO BE WIRED PER INTERCONNECT DIAGRAM & 100% TESTED FOR OPENS AND SHORTS

NOTES:

- CONNECTOR HOUSINGS ARE SHOWN AS VIEWED FROM TERMINAL INSERTION SIDE
- LABEL P102, P102A, P302, P302A, LEFT AND RIGHT PER 19A115740P1
- LABEL CABLE WITH EGE PART NO. PER 19A115740P1

DETAIL #1

NOTE: CUT CABLE LENGTH AND LABEL CONNECTORS PER FOLLOWING CHART:

PART NUMBER	LENGTH "C"	LABEL CONNECTOR "LEFT"	LABEL CONNECTOR "RIGHT"
1	64.50"	P5/P7	P6/P8
2	70.00"	P3/P9	P4/P10
3	78.00"	P1	P2

CONNECTOR "LEFT" / "RIGHT"	CONNECTOR P102/P302	WIRE DESCRIPTION "A"	CONNECTOR J102A/J302A	WIRE DESCRIPTION "B"
PLUG; SIMILAR TO AMP CAT. NO. 172165-1 CONTACTS: PIN SIMILAR TO AMP CAT. NO. 170364-1 OR EQUIVALENTS	PLUG; SIMILAR TO AMP CAT. # 205204-1 CONTACTS: PIN SIMILAR TO AMP CAT. NO. 66506-3 SCREW & RETAINER AMP CAT. NO. 205980-1 OR EQUIVALENTS	SF22 WIRE, EGE PART NO. 19A115870 #22 AWG (19 STRANDS OF #34 WIRE) 600 VRMS @ -40° TO +105° C. TEMP. RANGE	RECEPTACLE; SIMILAR TO AMP CAT. # 205203-1 CONTACTS: SOCKET SIMILAR TO AMP CAT. NO. 66504-3 OR EQUIVALENTS	USE C & M PN 19523 CABLING. OR EQUIVALENTS

(19B803639, Sheet 1, Rev. 4)

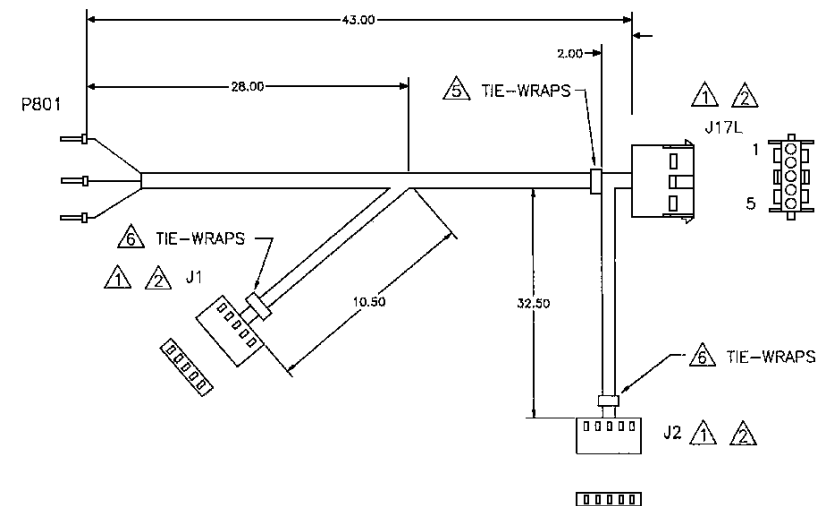

NOTES:

- CONNECTOR HOUSINGS ARE SHOWN AS VIEWED FROM TERMINAL INSERTION SIDE
- LABEL J17L, J1, AND J2 PER 19A115740P1
- LABEL CABLE WITH EGE PART NO. PER 19A115740P1
- CABLE TO BE WIRED PER INTERCONNECT DIAGRAM & 100% TESTED FOR OPENS AND SHORTS
- TIE-WRAP THIS SECTION OF CABLE EVERY 5 INCHES STARTING AT 2 INCHES FROM 10-PIN PLUG
- TIE-WRAP THIS CABLE SECTION EVERY 2 INCHES STARTING AT 2 INCHES FROM 5-PIN PLUG

P801 CONTACTS	J17L	WIRE DESCRIPTION	J1 AND J2
EGE PART # 19B209288P2 SIMILAR TO MOLEX CAT. NO. 02-09-2101 OR EQUIVALENTS	HOUSING SIMILAR TO AMP CAT. # 350810-1 CONTACTS EGE PART NO. 19B02523P83, SIMILAR TO AMP CAT. NO. 350919-3 OR EQUIVALENTS	V16 WIRE, EGE PART NO. 19A116850 #16 AWG (26 STRANDS OF .010 DIA. WIRE) 600 VRMS @ -40° TO +105° C. TEMP. RANGE UL1013 SF22 WIRE, EGE PART NO. 19A115870 #22 AWG (19 STRANDS OF #34 WIRE) 600 VRMS @ -40° TO +105° C. TEMP. RANGE	EGE PART # 19A700041P31 SIMILAR TO MOLEX CAT. NO. 22-01-2055 EGE # 19A704779P26 SIMILAR TO MOLEX CAT. NO. 08-55-0101 OR EQUIVALENTS

(19B803595, Sheet 1, Rev. 2)

UNLESS OTHERWISE SPECIFIED
ALL WIRES SF22

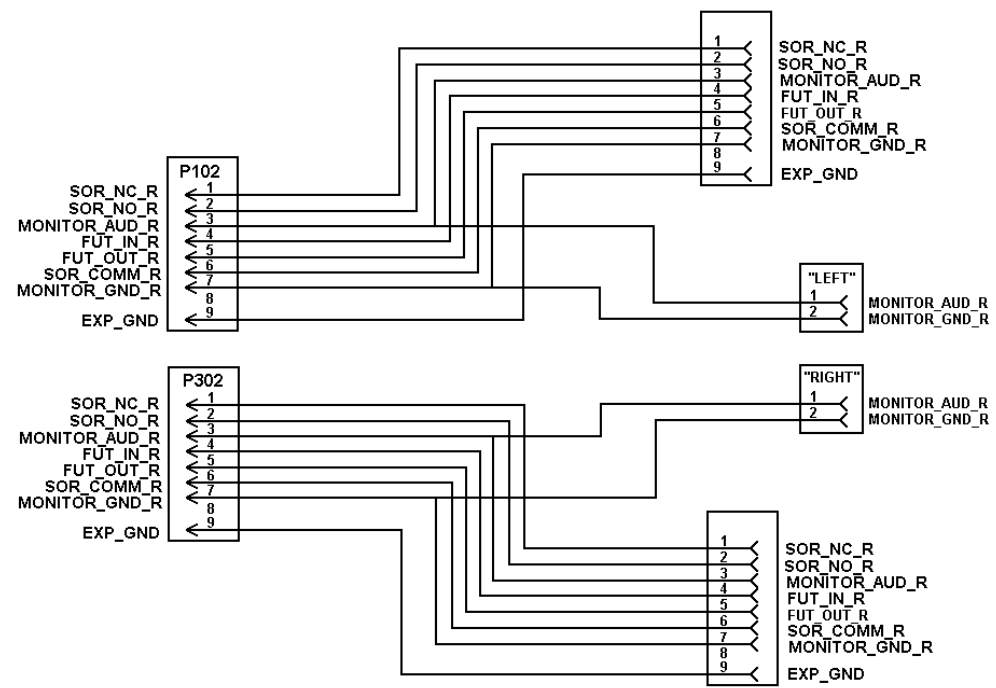

ALL WIRES TO BE AWG 22 GAUGE
UNLESS OTHERWISE NOTED.

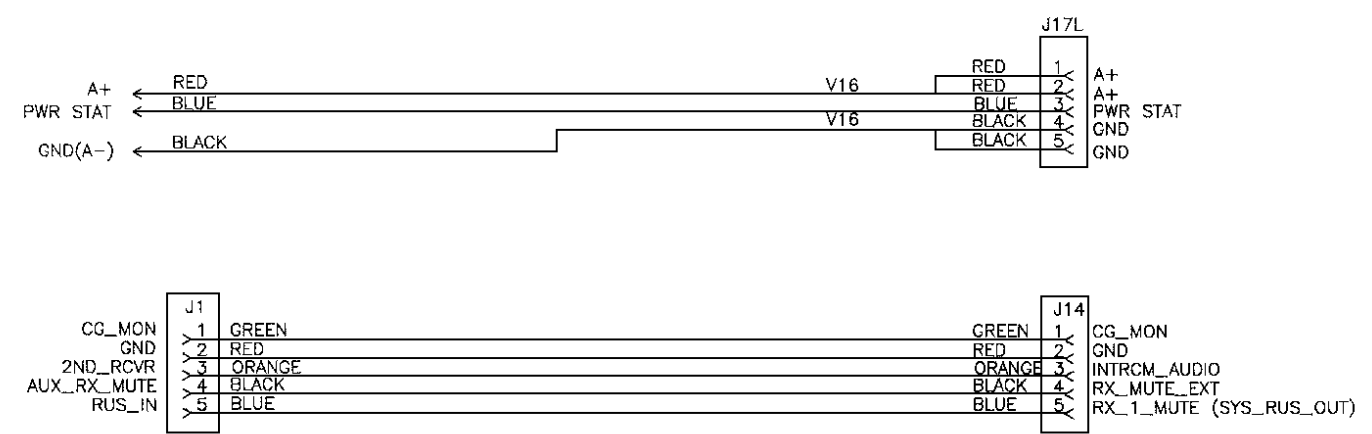

Signal Cable
19B803639P1-P3

(19B803639, Sheet 2, Rev. 4)

Second Receiver Power Cable
19B803595P1

(19B803595, Sheet 2, Rev. 2)

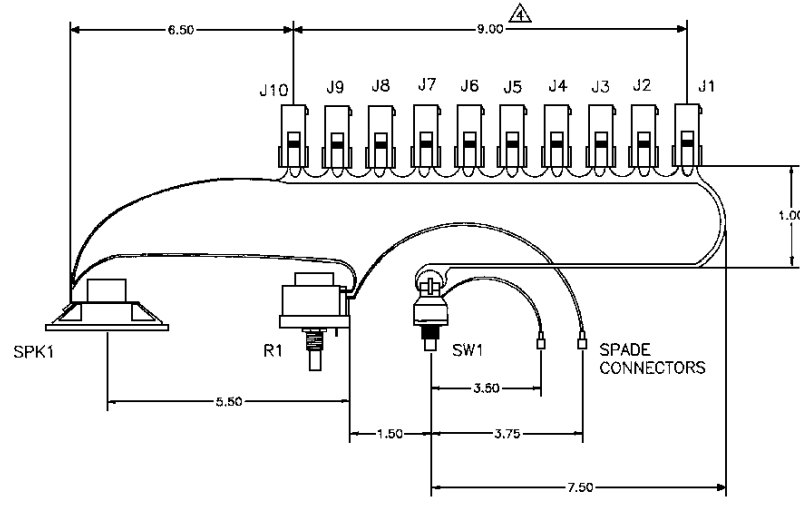

- PART ① CABLE TO BE WIRED PER INTERCONNECT DIAGRAM & 100% TESTED FOR OPENS AND SHORTS
- NOTES:
- △ CONNECTOR HOUSINGS ARE SHOWN AS VIEWED FROM TERMINAL INSERTION SIDE
 - △ LABEL P1/P3, P2/P4, J1/J4, J2/J5, AND J3/J6 PER 19A115740P1
 - 3 LABEL CABLE WITH EGE PART NO. PER 19A115740P1
 - △ PLACE AT 1 INCH CENTERS FOR 10 PIECES.

J1 THRU J10	SPK1	WIRE DESCRIPTION	R1	SW1	SPADE CONNECTORS
PLUG; SIMILAR TO AMP CAT. NO. 172157-1 CONTACTS SIMILAR TO: AMP CAT. NO. 170366-1 OR EQUIVALENTS	8 OHM, 2 WATT LOUDSPEAKER SIMILAR TO EGE 344A3136P1 BUT WITH NO MOLEX CONNECTOR HOUSING OR #22 SWG ORANGE WIRES. SPEAKER IS SIMILAR TO FOSTER ELECTRONIC C072A01A0000 8 OHM, 2 WATT,	Y20 WIRE, EGE PART NO. 19A118888 #20 AWG (10 STRANDS OF .010 DIA. WIRE) 600 VRMS @ -40 TO +105° C. TEMP. RANGE UL1015	RESISTOR, VARIABLE 25 WATT (25 OHM) EGE M-2R33P8, SIMILAR TO OHMITE MODEL "H" CAT. NO. RHS25R OR EQUIVALENT.	GRAYHILL SWITCH ID NO. 71B36-01-1-10N-C OR EQUIVALENTS	SPADE CONNECTOR EGE 4029484P7 OR EQUIVALENTS

(19B803634, Sheet 1, Rev. 3)

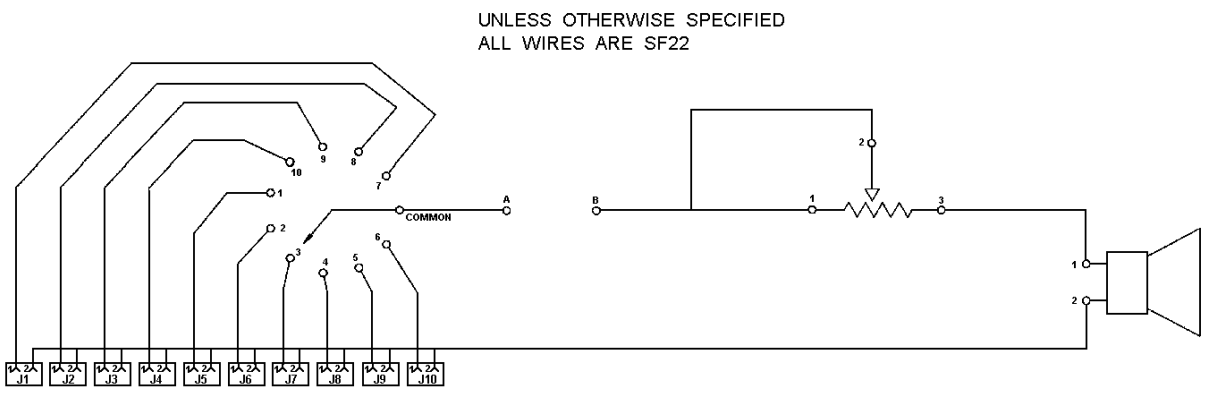

Monitor Panel Harness
19B803634P1

(19B803634, Sheet 2, Rev. 3)

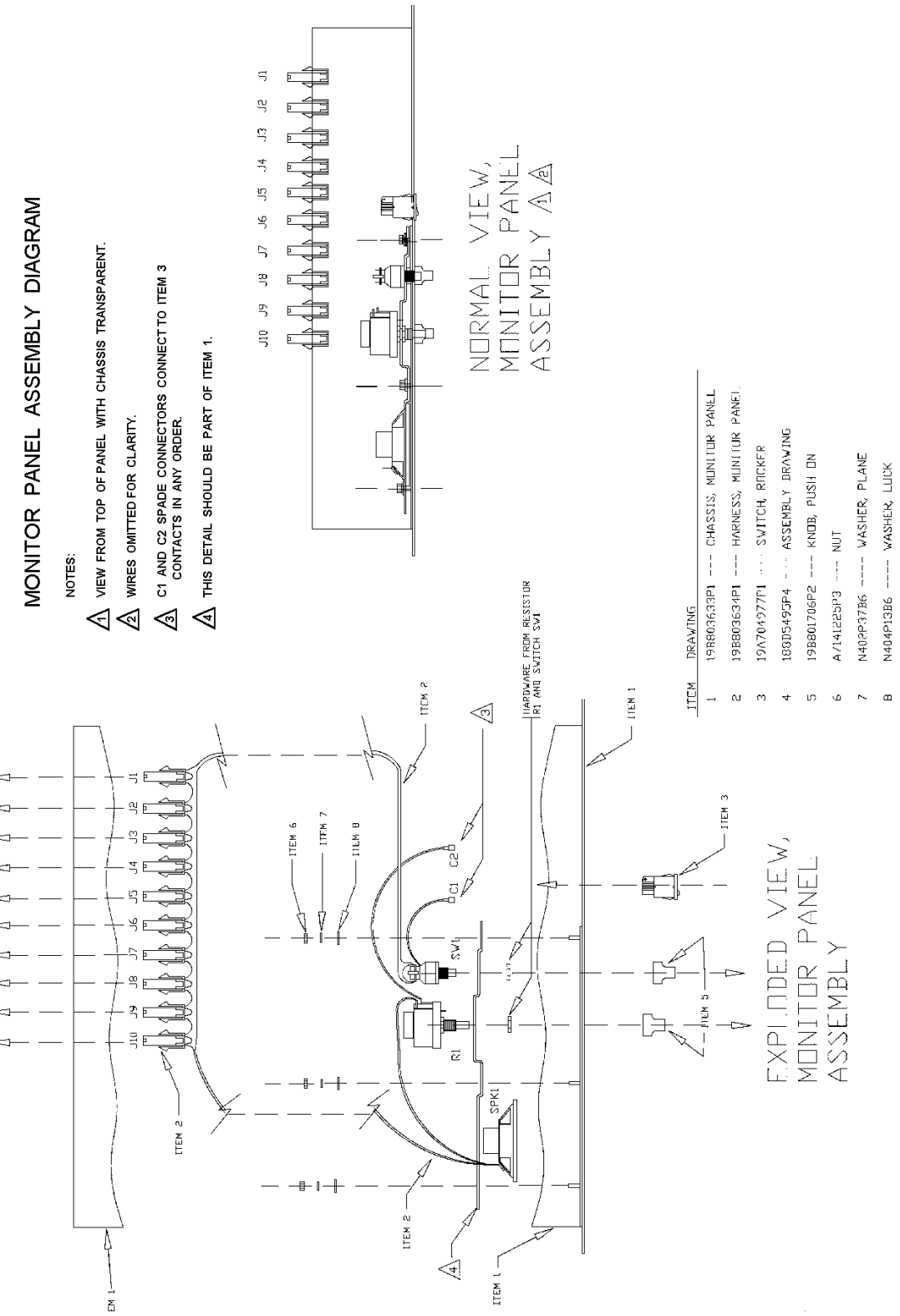

MONITOR PANEL ASSEMBLY DIAGRAM

- NOTES:
- △ VIEW FROM TOP OF PANEL WITH CHASSIS TRANSPARENT.
 - △ WIRES OMITTED FOR CLARITY.
 - △ C1 AND C2 SPADE CONNECTORS CONNECT TO ITEM 3 CONTACTS IN ANY ORDER.
 - △ THIS DETAIL SHOULD BE PART OF ITEM 1.

Monitor Panel
188D5495G1

(188D5453, Rev. 0)

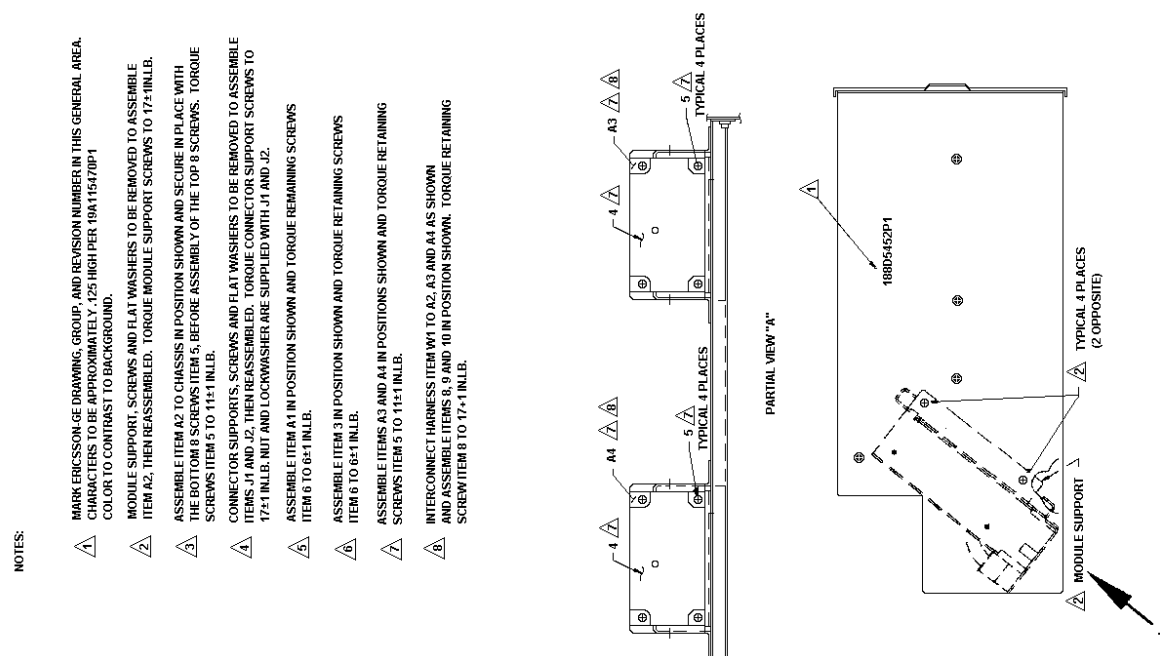
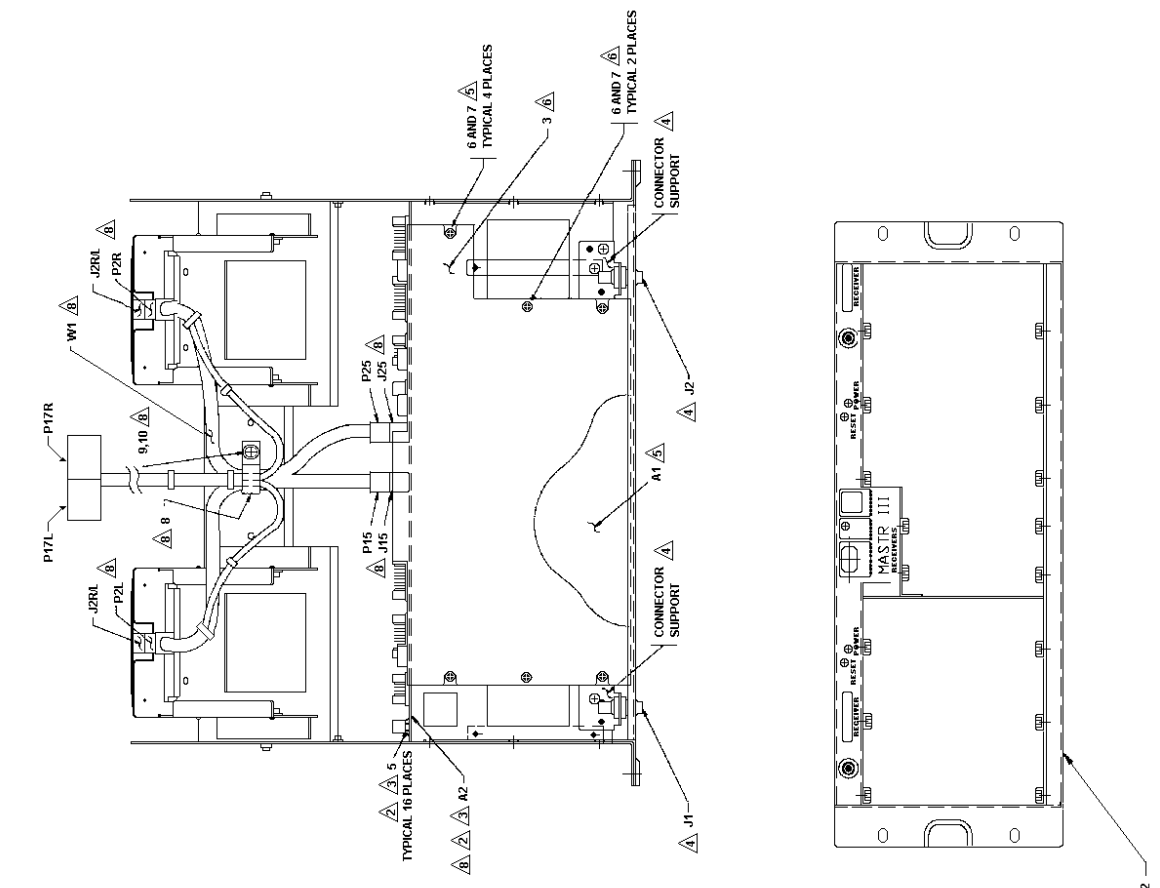

- NOTES:
- 1 MARKER/SCISSOR DRAWING, GROUP, AND REVISION NUMBER IN THIS GENERAL AREA CHARACTERS TO BE APPROXIMATELY .125 HIGH PER 19A115470P1 COLOR TO CONTRAST TO BACKGROUND.
 - 2 MODULE SUPPORT, SCREWS AND FLAT WASHERS TO BE REMOVED TO ASSEMBLE ITEM A2, THEN REASSEMBLED. TORQUE MODULE SUPPORT SCREWS TO 17± IN.LB.
 - 3 ASSEMBLE ITEM A2 TO CHASSIS IN POSITION SHOWN AND SECURE IN PLACE WITH THE BOTTOM 8 SCREWS ITEM 5, BEFORE ASSEMBLY OF THE TOP 8 SCREWS. TORQUE SCREWS ITEM 5 TO 11± IN.LB.
 - 4 CONNECTOR SUPPORTS, SCREWS AND FLAT WASHERS TO BE REMOVED TO ASSEMBLE ITEMS J1 AND J2, THEN REASSEMBLED. TORQUE CONNECTOR SUPPORT SCREWS TO 17± IN.LB. NUT AND LOCKWASHER ARE SUPPLIED WITH J1 AND J2.
 - 5 ASSEMBLE ITEM A1 IN POSITION SHOWN AND TORQUE REMAINING SCREWS ITEM 6 TO 6± IN.LB.
 - 6 ASSEMBLE ITEM 3 IN POSITION SHOWN AND TORQUE REMAINING SCREWS ITEM 6 TO 6± IN.LB.
 - 7 ASSEMBLE ITEMS A3 AND A4 IN POSITIONS SHOWN AND TORQUE REMAINING SCREWS ITEM 5 TO 11± IN.LB.
 - 8 INTERCONNECT HARNESS ITEM W1 TO A2, A3 AND A4 AS SHOWN AND ASSEMBLE ITEMS 8, 9 AND 10 IN POSITION SHOWN. TORQUE REMAINING SCREW ITEM 8 TO 17± IN.LB.

MASTR III Multiple Receiver Shelf
188D5452G1

(188D5452, Rev. 2)

COMPONENT SIDE

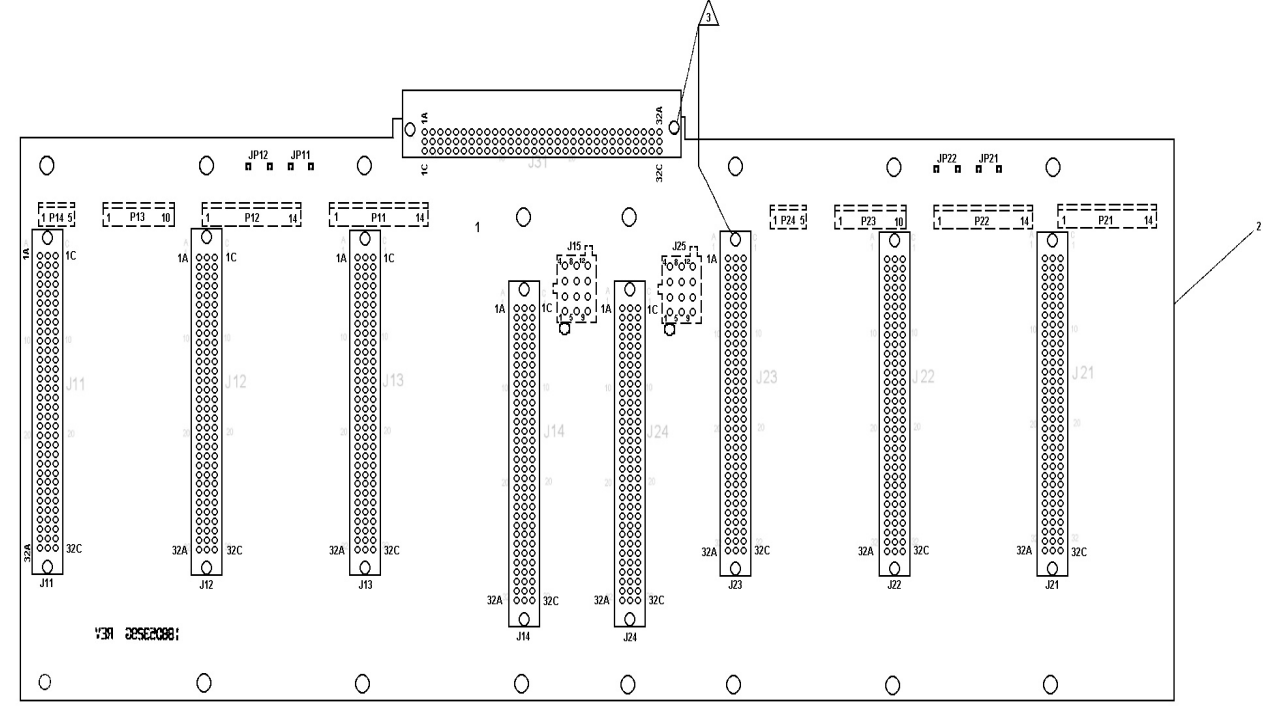

SOLDER SIDE

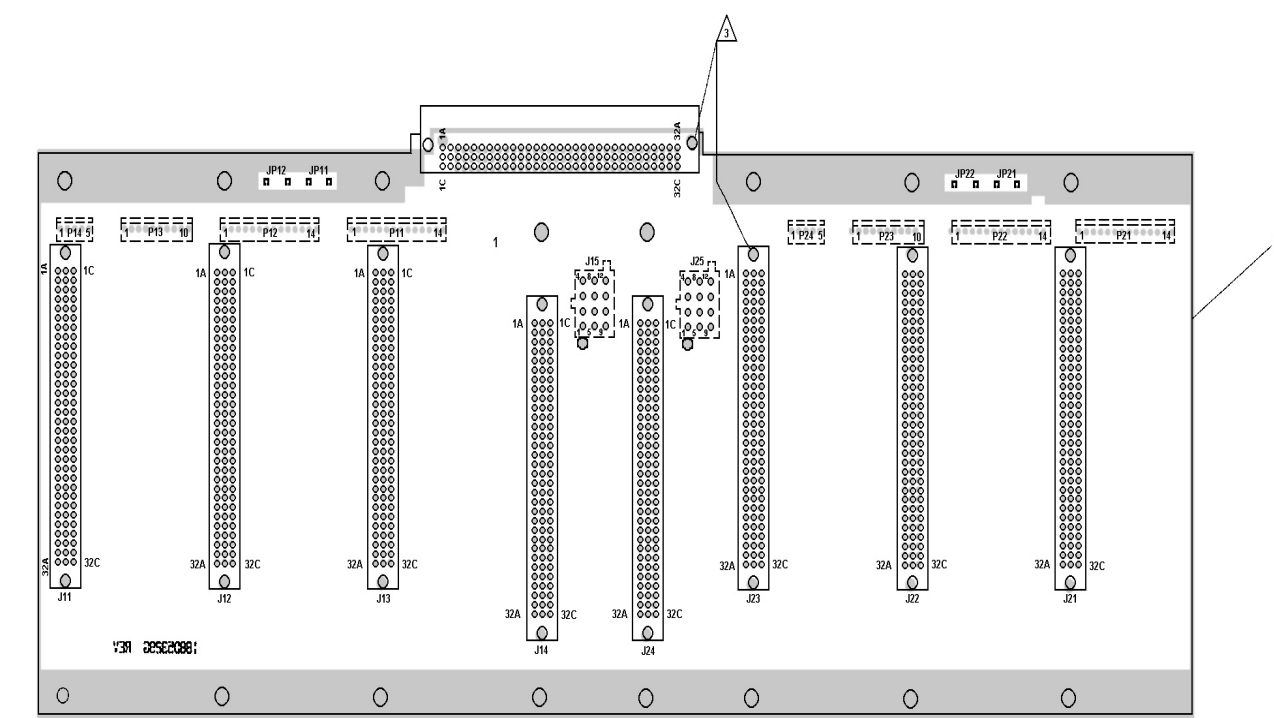

Backplane Board
188D5329G1

(188D5329, Rev. 2)
(188D5330, Layer 1, Rev. 2)

RX SYNTHESIZER_L

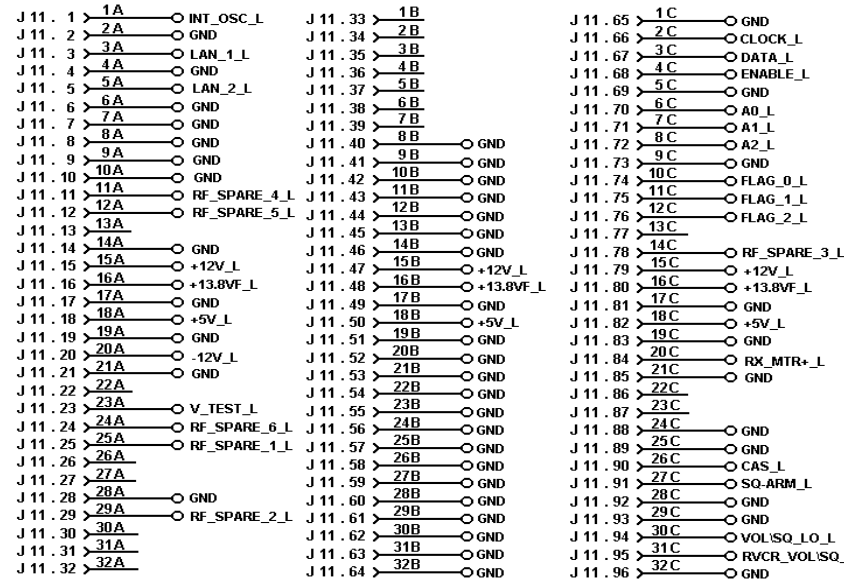

RX IF_L

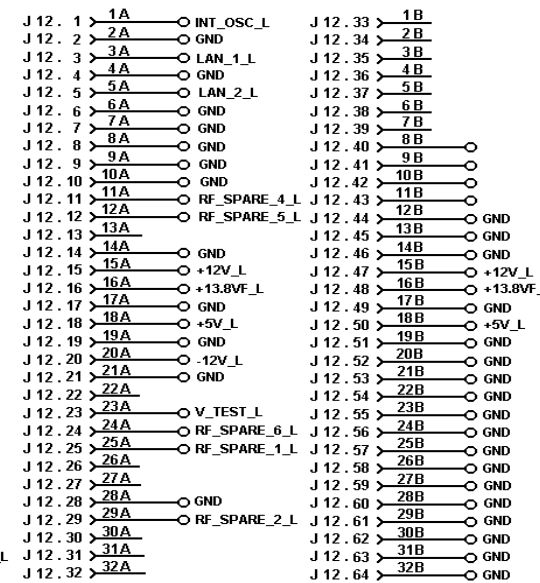

RX FRONT END_L

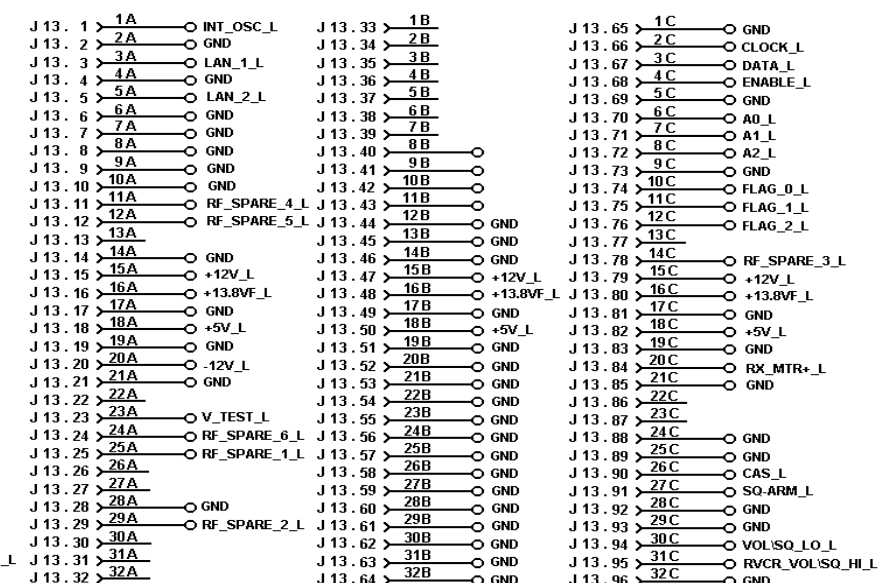

SYSTEM MODULE_L

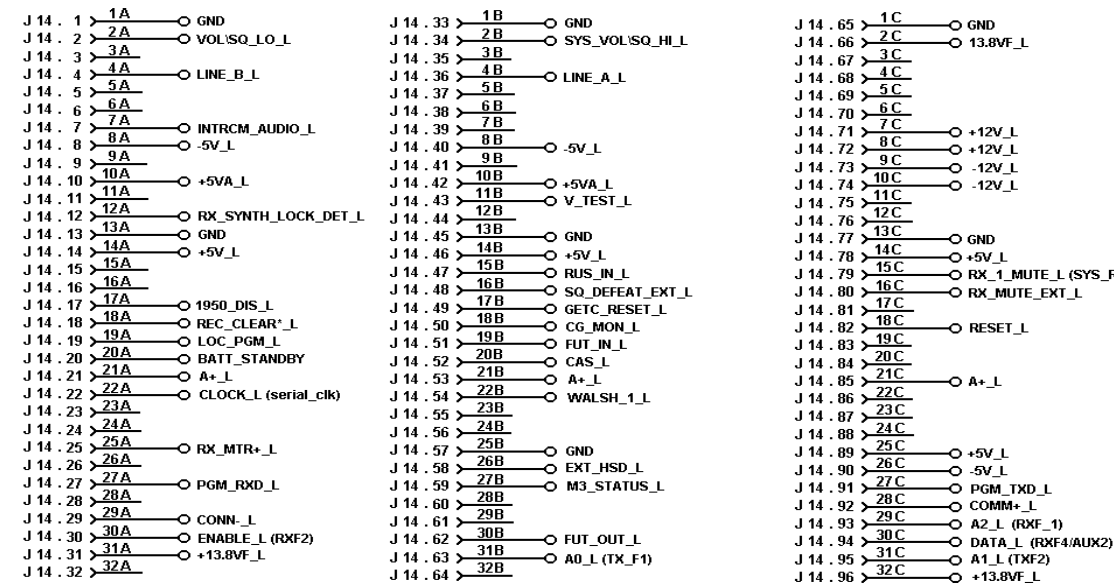

NOTE:

MULTIPLE RECEIVER	BASE STATION
GETC_RESET	VG_PTT_OUT
REC_CLEAR*	REPEAT_PTT_OUT
LOC_PGM	DC_CNTRL_1
FUT_IN	DC_CNTRL_2
FUT_OUT	RXF3/AUX1
RX_MUTE_EXT	COMB_PTT_IN
SQ_DEFEAT_EXT	DELAYED_PTT_IN
V_TEST	EXT_JCK
A0	TXF1
A1	TXF2
A2	RXF1
DATA	RXF4/AUX2
RX_SYNTH_LOCK_DET	COMB_PTT_OUT

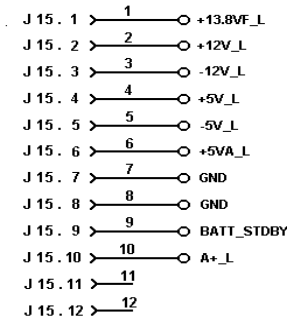

POWER_L

NOTICE

AT E & M:
VG_ALERT_L TO PIN 2 OR 8 OF P12
VG_ALERT_R TO PIN 2 OR 8 OF P22

THIS SCHEMATIC DIAGRAM APPLIES TO
MODEL NO. PL188D5329
REV LETTER

- J31.1 ← 1 A RX_1_MUTE_L (SYS_RUS_OUT)
- J31.2 ← 2 A FLAG_2_L
- J31.3 ← 3 A A1_L (TXF2)
- J31.4 ← 4 A CLOCK_L (SERIALCLK)
- J31.5 ← 5 A DATA_L (RXF4/AUX2)
- J31.6 ← 6 A LOC_PGM_L
- J31.7 ← 7 A PGM_RXD_L
- J31.8 ← 8 A GND
- J31.9 ← 9 A GND
- J31.10 ← 10 A GND
- J31.11 ← 11 A GETC_RESET_L
- J31.12 ← 12 A LINE_A_L
- J31.13 ← 13 A GND
- J31.14 ← 14 A GND
- J31.15 ← 15 A GND
- J31.16 ← 16 A
- J31.17 ← 17 A
- J31.18 ← 18 A GND
- J31.19 ← 19 A GND
- J31.20 ← 20 A GND
- J31.21 ← 21 A LINE_A_R
- J31.22 ← 22 A GETC_RESET_R
- J31.23 ← 23 A GND
- J31.24 ← 24 A GND
- J31.25 ← 25 A GND
- J31.26 ← 26 A PGM_RXD_R
- J31.27 ← 27 A LOC_PGM_R
- J31.28 ← 28 A DATA_R (RXF4/AUX2)
- J31.29 ← 29 A CLOCK_R (SERIAL CLK)
- J31.30 ← 30 A A1_R (TXF2)
- J31.31 ← 31 A FLAG_2_R
- J31.32 ← 32 A RX_1_MUTE_R (SYS_RUS_OUT)

- J31.33 ← 1 B FLAG_O_L
- J31.34 ← 2 B -5V_L
- J31.35 ← 3 B AO_L (TXF1)
- J31.36 ← 4 B REC_CLEAR*_L
- J31.37 ← 5 B FUT_OUT_L
- J31.38 ← 6 B FUT_IN_L
- J31.39 ← 7 B PGM_TXD_L
- J31.40 ← 8 B COMM+_L
- J31.41 ← 9 B COMM-_L
- J31.42 ← 10 B INTRCM_AUDIO_L
- J31.43 ← 11 B
- J31.44 ← 12 B LINE_B_L
- J31.45 ← 13 B SQ-ARM_L (SQUELCH_WIPER_L)
- J31.46 ← 14 B
- J31.47 ← 15 B RCVR_VOL/SQ_HI_L
- J31.48 ← 16 B
- J31.49 ← 17 B
- J31.50 ← 18 B RCVR_VOLISQ_HI_R
- J31.51 ← 19 B
- J31.52 ← 20 B SQ-ARM_R (SQUELCH_WIPER_R)
- J31.53 ← 21 B LINE_B_R
- J31.54 ← 22 B
- J31.55 ← 23 B INTRCM_AUDIO_R
- J31.56 ← 24 B COMM-_R
- J31.57 ← 25 B COMM+_R
- J31.58 ← 26 B PGM_TXD_R
- J31.59 ← 27 B FUT_IN_R
- J31.60 ← 28 B FUT_OUT_R
- J31.61 ← 29 B REC_CLEAR*_R
- J31.62 ← 30 B AO_R (TXF1)
- J31.63 ← 31 B -5V_R
- J31.64 ← 32 B FLAG_O_R

- J31.65 ← 1 C FLAG_1_L
- J31.66 ← 2 C A2_L (RXF1)
- J31.67 ← 3 C ENABLE_L (RXF2)
- J31.68 ← 4 C M3_STATUS_L
- J31.69 ← 5 C RESET_L
- J31.70 ← 6 C +5V_L
- J31.71 ← 7 C +5V_L
- J31.72 ← 8 C INT_OSC_L
- J31.73 ← 9 C GND
- J31.74 ← 10 C +12V_L
- J31.75 ← 11 C +12V_L
- J31.76 ← 12 C -12V_L
- J31.77 ← 13 C -12V_L
- J31.78 ← 14 C +13.8VF_L
- J31.79 ← 15 C +13.8VF_L
- J31.80 ← 16 C
- J31.81 ← 17 C
- J31.82 ← 18 C +13.8VF_R
- J31.83 ← 19 C +13.8VF_R
- J31.84 ← 20 C -12V_R
- J31.85 ← 21 C -12V_R
- J31.86 ← 22 C +12V_R
- J31.87 ← 23 C +12V_R
- J31.88 ← 24 C GND
- J31.89 ← 25 C INT_OSC_R
- J31.90 ← 26 C +5V_R
- J31.91 ← 27 C +5V_R
- J31.92 ← 28 C RESET_R
- J31.93 ← 29 C M3_STATUS_R
- J31.94 ← 30 C ENABLE_R (RXF2)
- J31.95 ← 31 C A2_R (RXF1)
- J31.96 ← 32 C FLAG_1_R

- P11.1 ← 1 VOLISQ_LO_L
- P11.2 ← 2 RCVR_VOLISQ_HI_L
- P11.3 ← 3 LINE_A_L
- P11.4 ← 4 LINE_B_L
- P11.5 ← 5 CAS_L
- P11.6 ← 6 RUS_IN_L
- P11.7 ← 7 CG_MON_L
- P11.8 ← 8 WALSH_1_L
- P11.9 ← 9 GND
- P11.10 ← 10 1950_DIS_L
- P11.11 ← 11 RX_1_MUTE_L (SYS_RUS_OUT)
- P11.12 ← 12 GETC_RESET_L
- P11.13 ← 13 RX_SYNTH_LOCK_DET_L
- P11.14 ← 14

- P13.1 ← 1 RX_MTR+_L
- P13.2 ← 2 V_TEST_L
- P13.3 ← 3 CAS_L
- P13.4 ← 4 RX_1_MUTE_L (SYS_RUS_OUT)
- P13.5 ← 5 SYS_VOLISQ_HI_L
- P13.6 ← 6 VOLISQ_LO_L (AGROUND)
- P13.7 ← 7 CG_MON_L
- P13.8 ← 8 RX_MUTE_EXT_L
- P13.9 ← 9 SQ_DEFEAT_EXT_L
- P13.10 ← 10 GND

GETC_L

- P12.1 ← 1 A+_L
- P12.2 ← 2 GND
- P12.3 ← 3 +12V_L
- P12.4 ← 4 -12V_L
- P12.5 ← 5 SYS_VOLISQ_HI_L
- P12.6 ← 6 VOLISQ_LO_L
- P12.7 ← 7 RCVR_VOLISQ_HI_L
- P12.8 ← 8 GND
- P12.9 ← 9 CAS_L
- P12.10 ← 10 CG_MON_L
- P12.11 ← 11 GETC_DATA_L
- P12.12 ← 12 EXT_HSD_L
- P12.13 ← 13 1950_DIS_L
- P12.14 ← 14 RX_1_MUTE_L (SYS_RUS_OUT)

VOICE GUARD_L

TEST_L

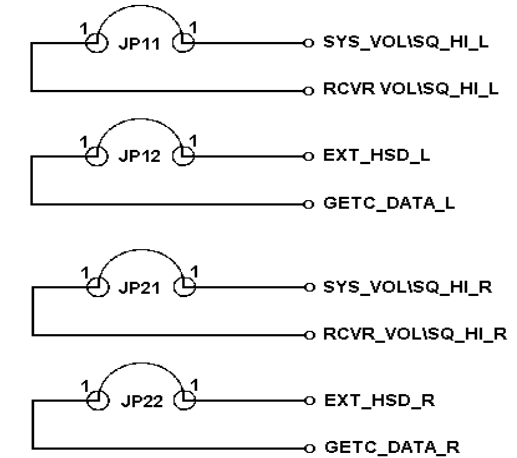

NOTE: CUT PWB RUNS FOR VG E/D ONLY

INTERFACE BOARD

- P14.1 ← 1 CG_MON_L
- P14.2 ← 2 GND
- P14.3 ← 3 INTRCM_AUDIO_L
- P14.4 ← 4 RX_MUTE_EXT_L
- P14.5 ← 5 RX_1_MUTE_L (SYS_RUS_OUT)

2ND RCVR_L

RX SYNTHESIZER_R

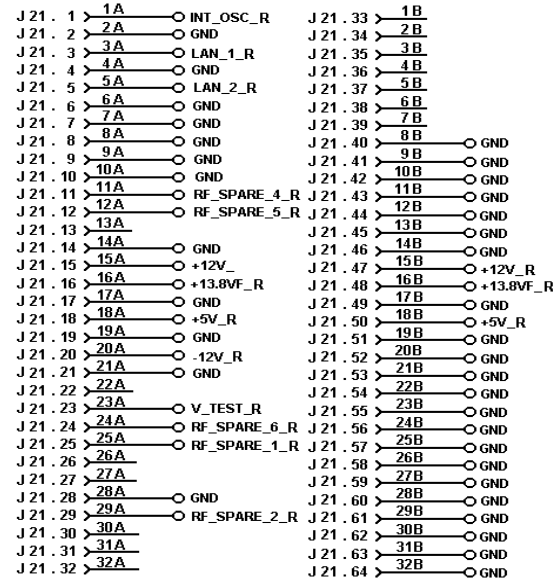

RX IF_R

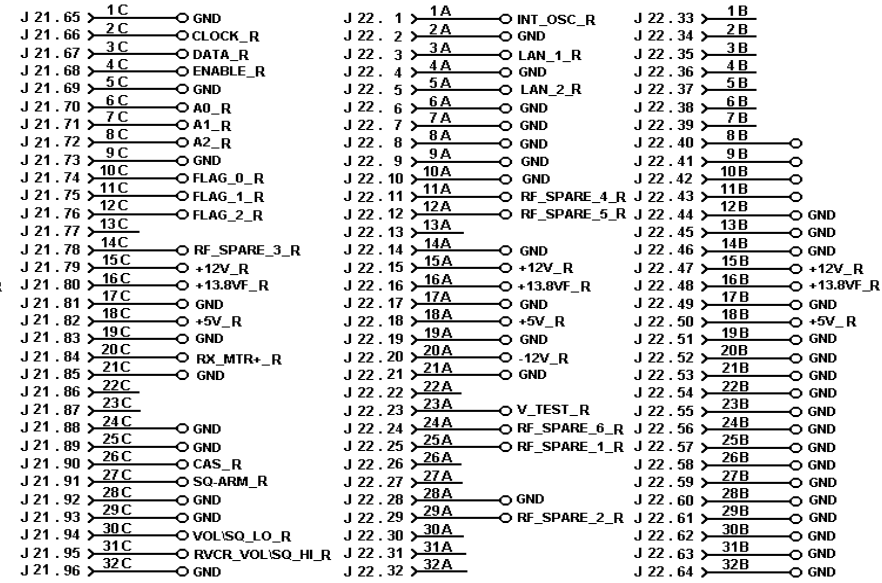

RX FRONT END_R

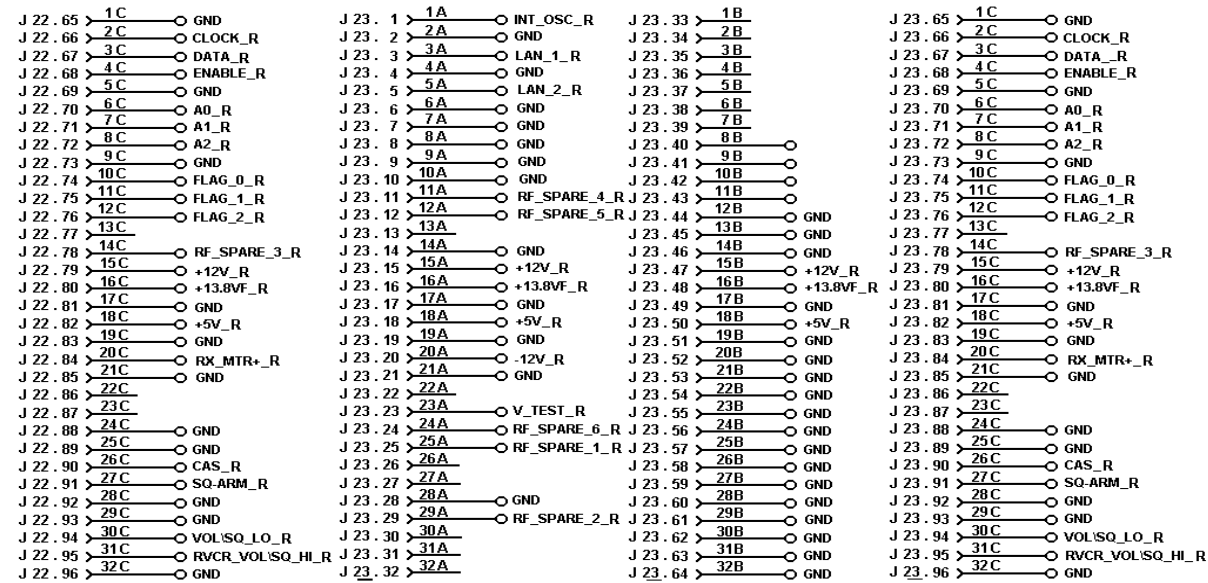

SYSTEM MODULE_R

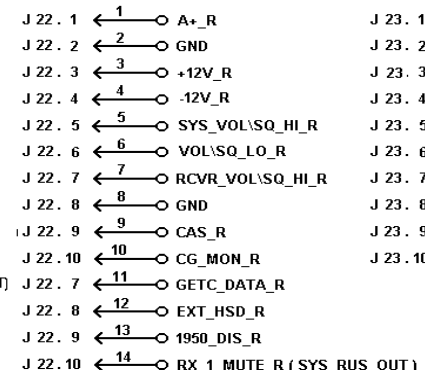
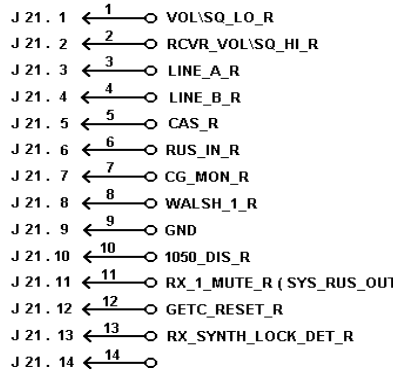
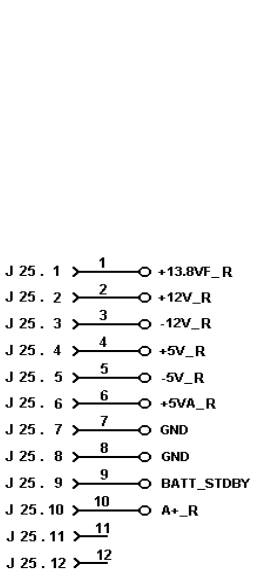
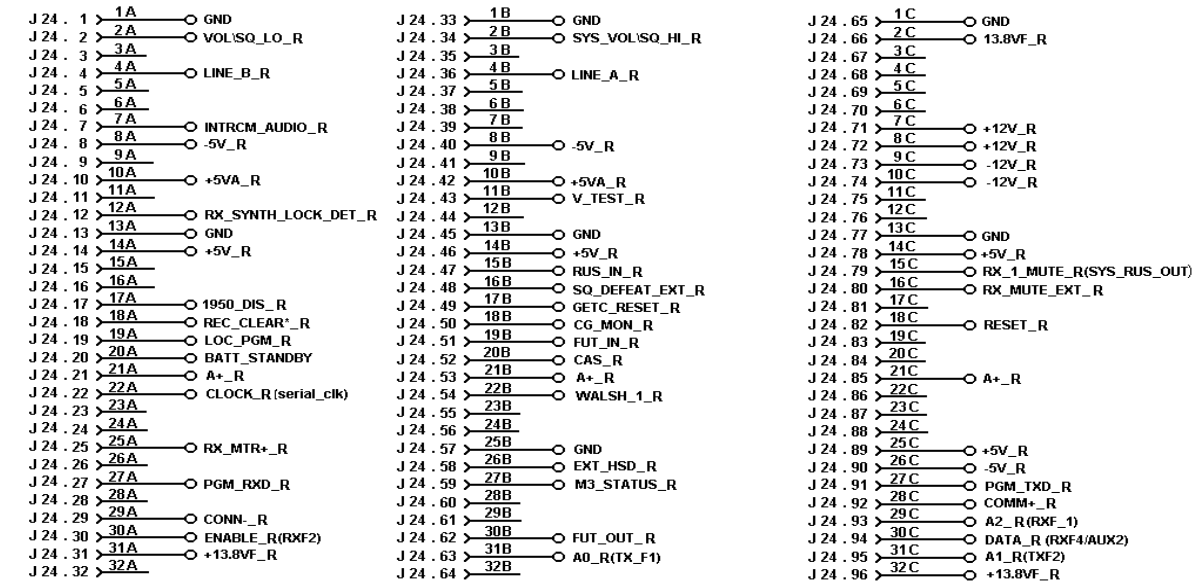

TEST_R

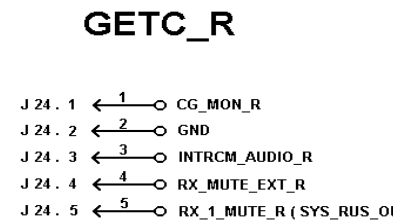

POWER_R

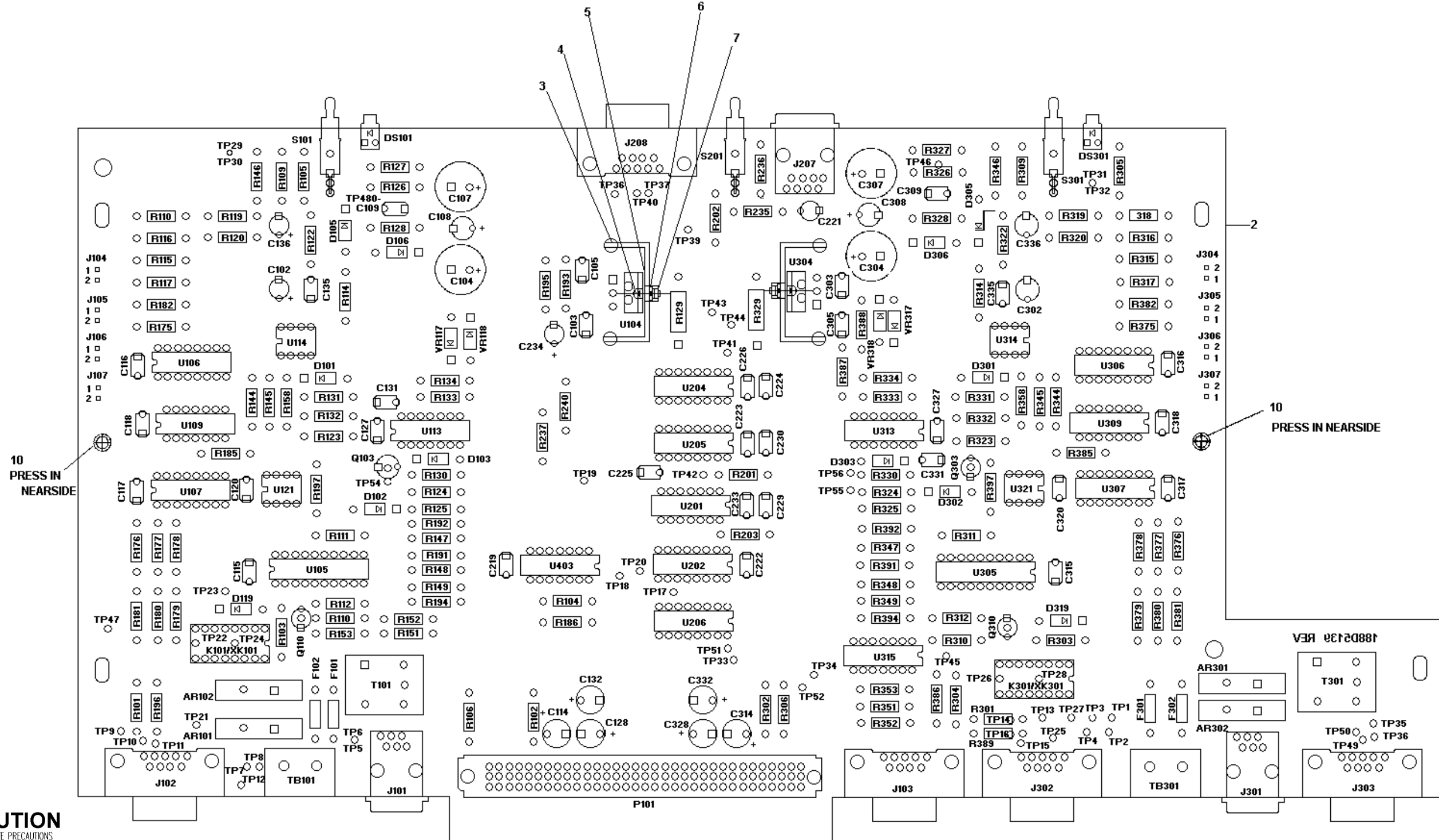

CAUTION
OBSERVE PRECAUTIONS
FOR HANDLING
ELECTROSTATIC
SENSITIVE
DEVICES

**Interface Board
188D5139G1**

(188D5139, Rev. 3)
(188D5138, Component Side, Rev. 1)

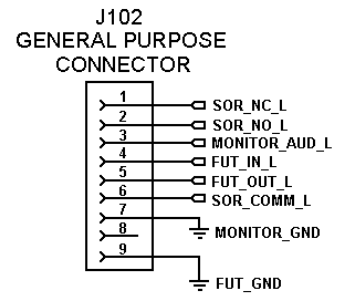
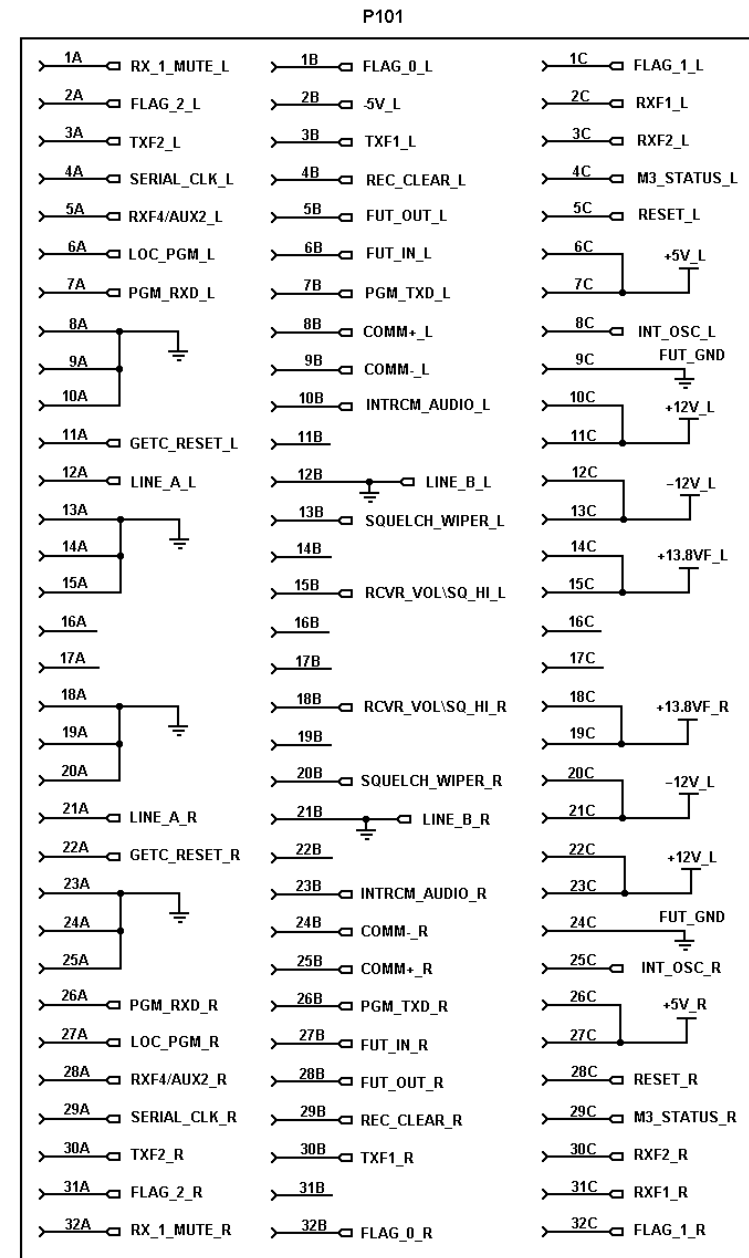

- NOTES:
- LEFT SECTION OF BOARD CONTAINS ALL CIRCUITRY FOR LEFT RECEIVER. RIGHT SECTION OF BOARD CONTAINS ALL CIRCUITRY RIGHT RECEIVER. CENTER SECTION OF BOARD CONTAINS DATA AND HANDSET PORT, TOGGLE/SELECT SWITCH AND ASSOCIATED LOGIC CIRCUITRY.
 - REFERENCE DESIGNATORS AND PIN NUMBERS SHOWN IN () ARE FOR REFERENCE ONLY.

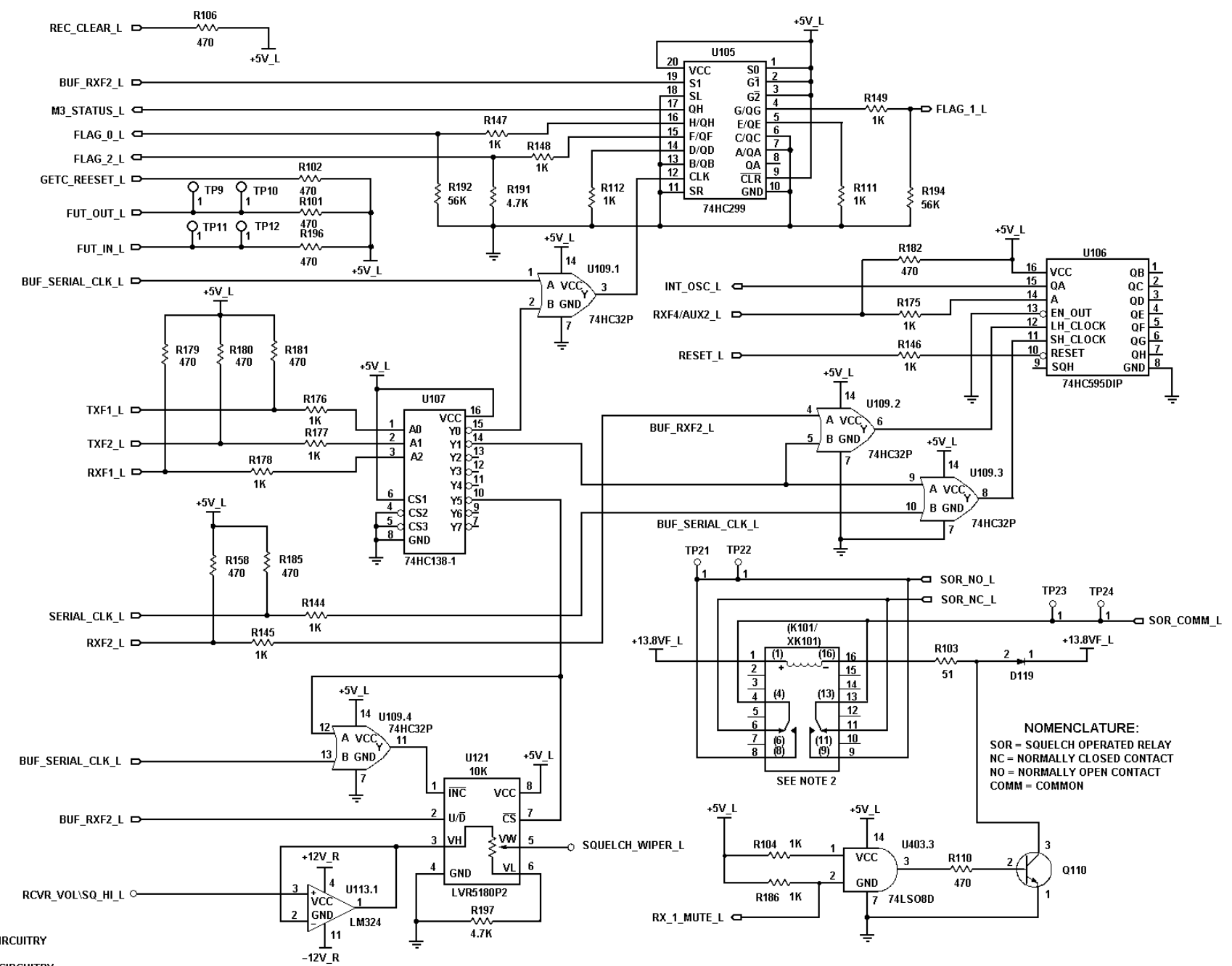

ALL RESISTORS ARE 1/4 WATT UNLESS OTHERWISE SPECIFIED AND RESISTOR VALUES ARE IN OHMS UNLESS FOLLOWED BY MULTIPLIER K OR M. CAPACITOR VALUES IN F UNLESS FOLLOWED BY MULTIPLIER U, N OR P. INDUCTANCE VALUES IN H UNLESS FOLLOWED BY MULTIPLIER M OR U.

NOTE:

BASE STATION NAME	AUX REC NAME
DC_CNTRL_1	LOC_PGM
DC_CNTR0_2	FUT_IN
REPEAT_PTT_OUT	REC_CLEAR
RXF3/AUX1	FUT_OUT
VG_PTT_OUT	GETC_RESET

NOMENCLATURE:
 SOR = SQUELCH OPERATED RELAY
 NC = NORMALLY CLOSED CONTACT
 NO = NORMALLY OPEN CONTACT
 COMM = COMMON

Interface Board
188D5139G1

(188D5137, Sheet 1, Rev. 2)

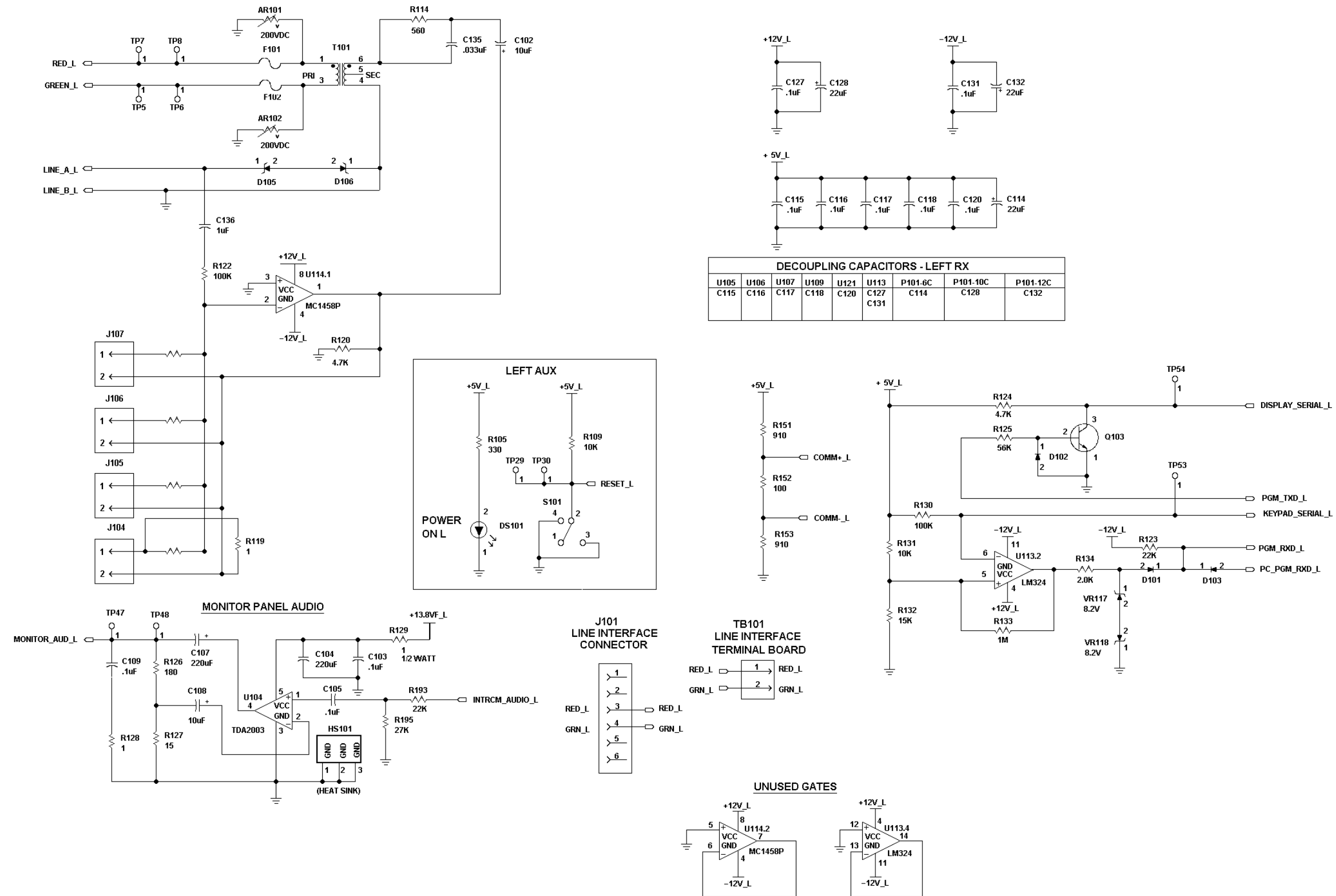

Interface Board
188D5139G1

(188D5137, Sheet 2, Rev. 3)

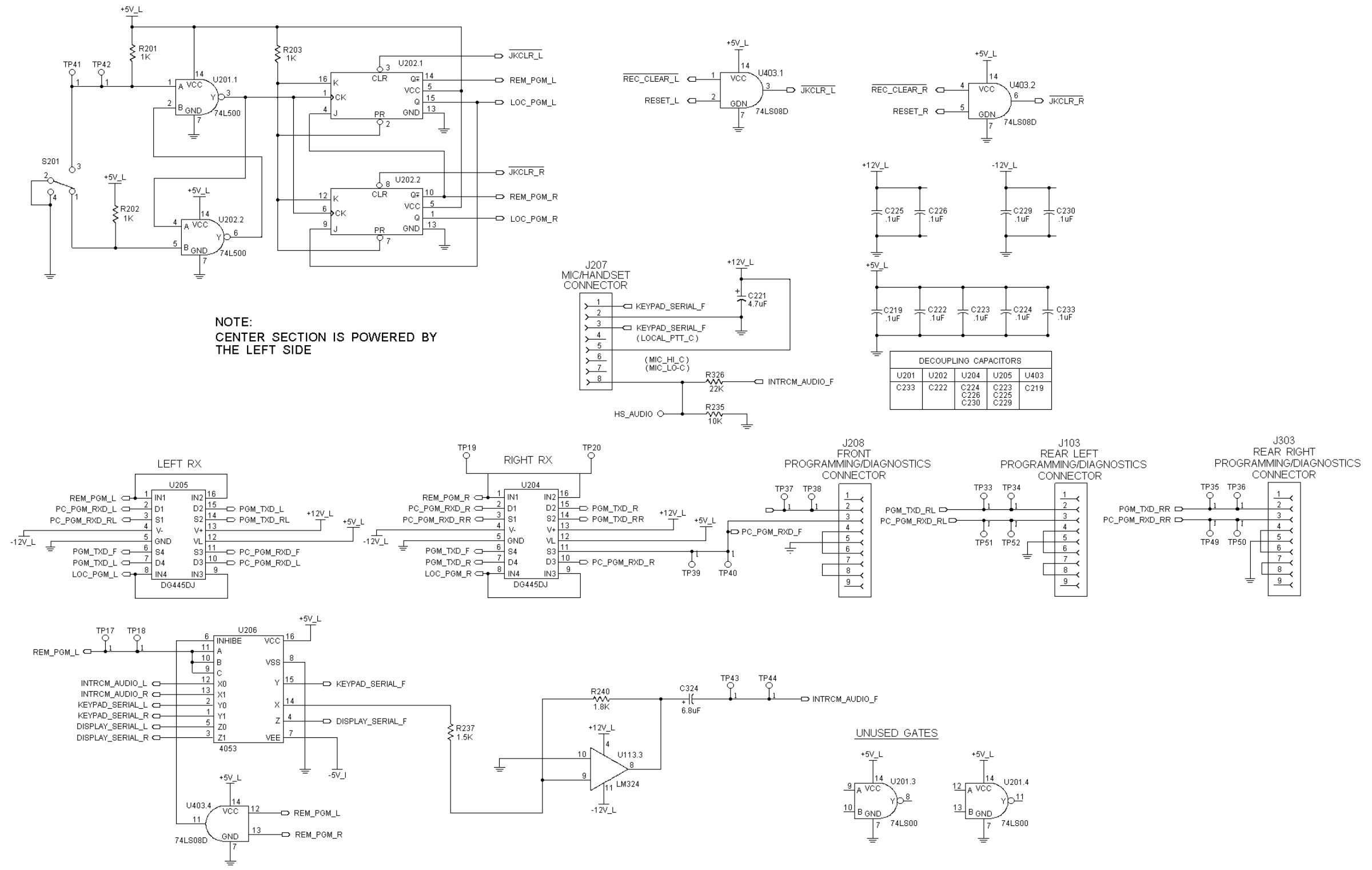

**Interface Board
188D5139G1**

(188D5137, Sheet 3, Rev. 1)

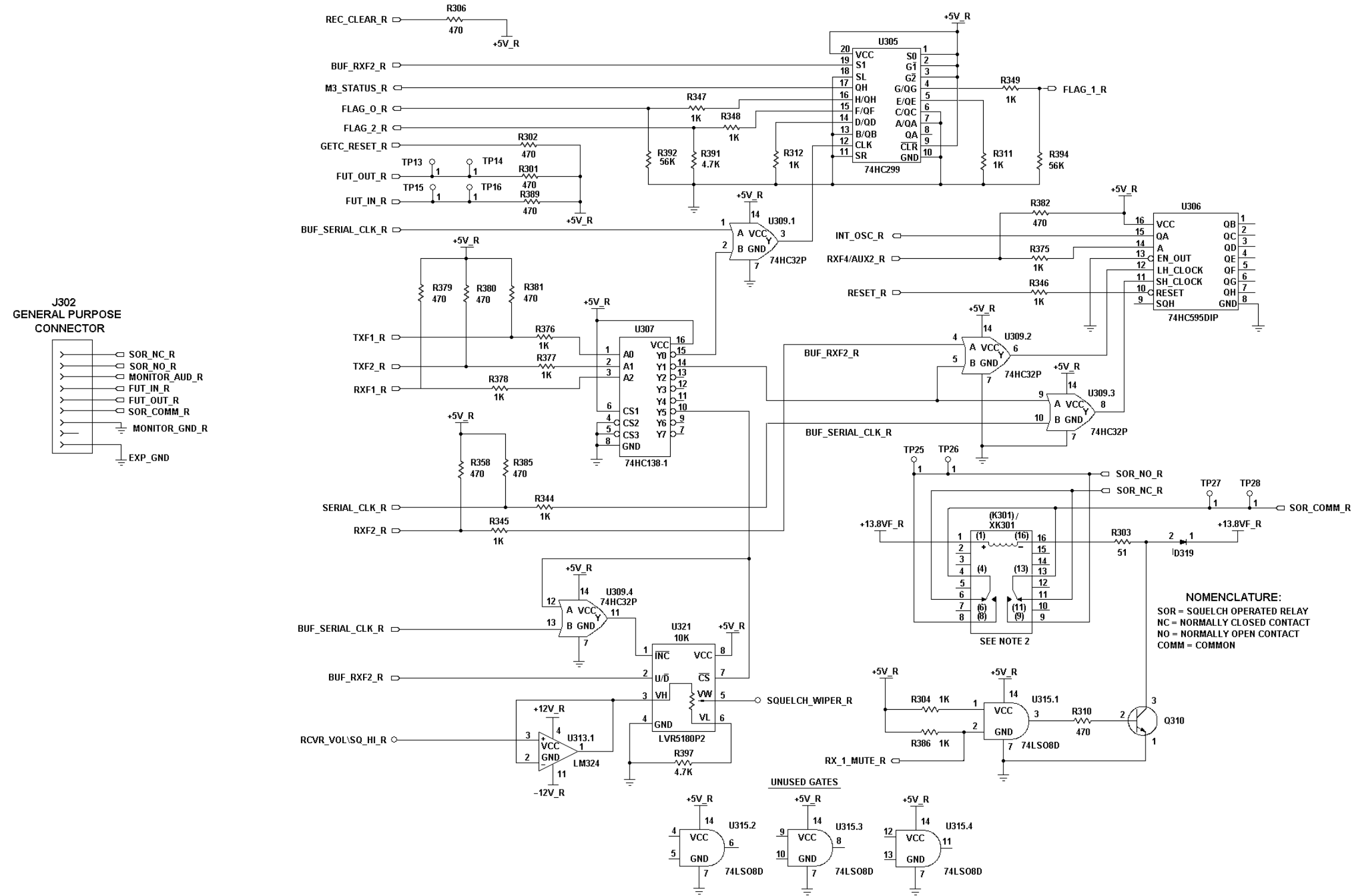

**Interface Board
188D5139G1**

(188D5137, Sheet 4, Rev. 1)

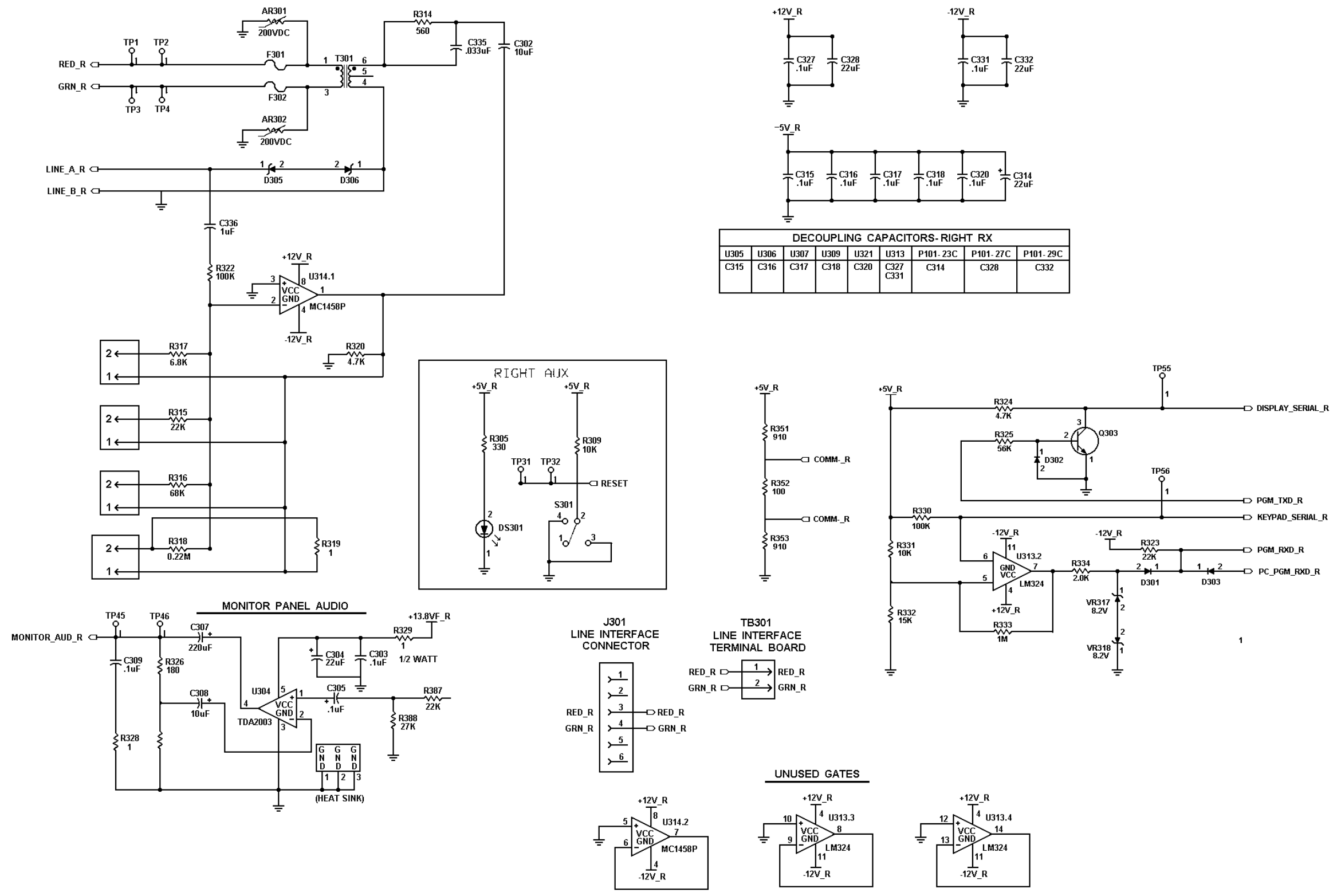

Interface Board
188D5139G1

(188D5137, Sheet 5, Rev. 3)

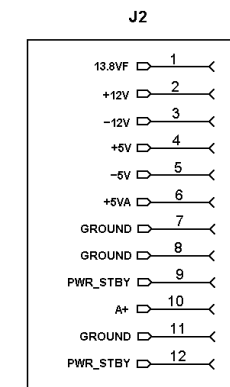
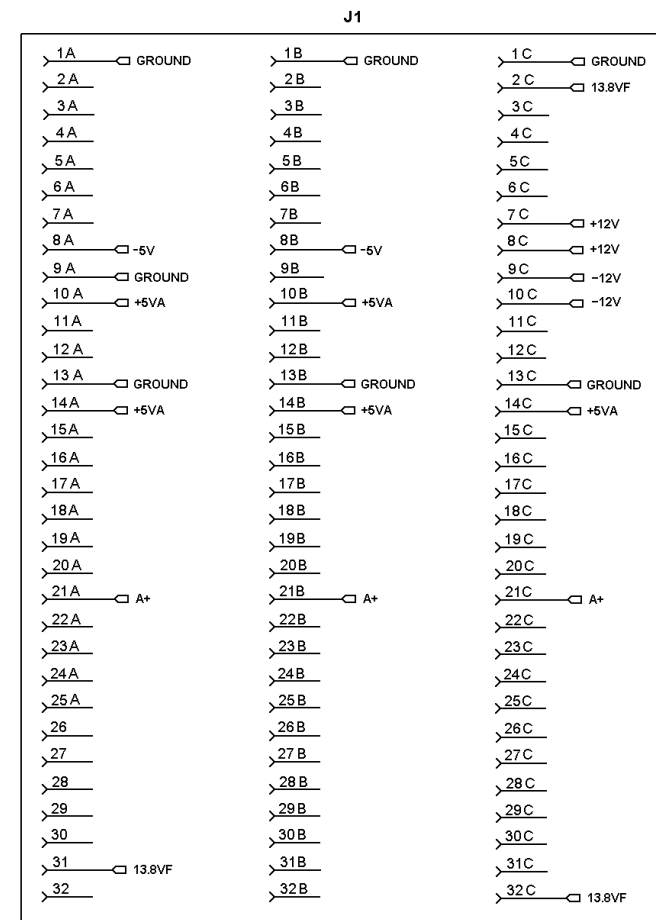
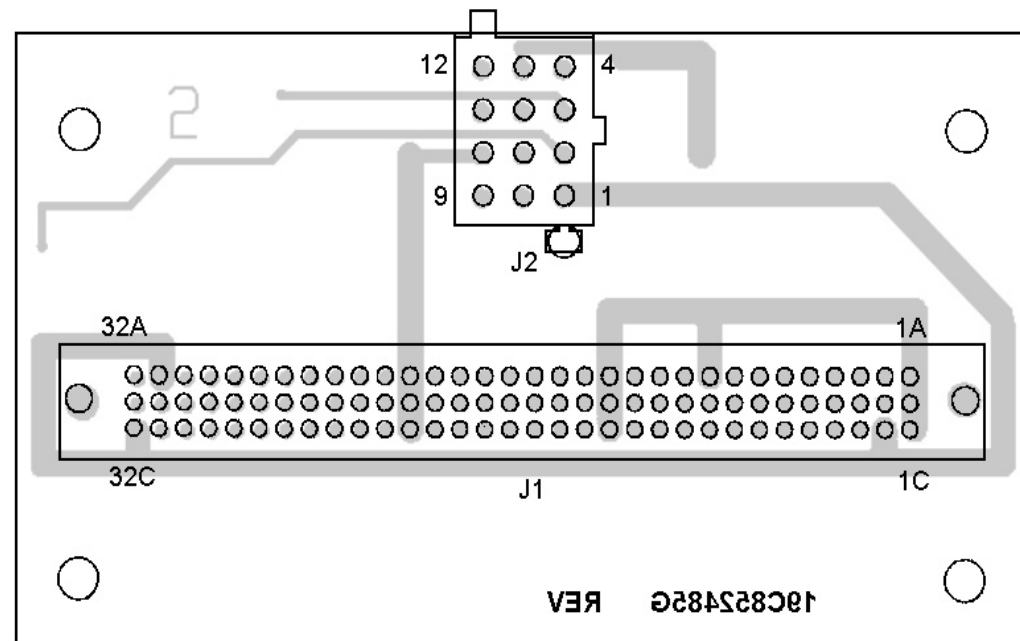

**Power Module Interconnect Board
19C852485G1**

(19C852485, Rev. 0)
(19C852484, Component Side, Rev. 2)

**Power Module Interconnect Board
19C852485G1**

(19C 852483, Rev. 2)

ASSEMBLY OF MULTIPLE RX SHELF FOR THE MASTR III INDOOR CABINET APPLICATION.

- ⚠ 'RIGHT' CHANNEL MODULES WILL REPLACE THE BLANK PANEL (19C852520P1) LOCATED IN THE RIGHT SIDE OF THE RECEIVER SHELF.
- ⚠ IF ONLY ONE CHANNEL IS TO BE LOADED INTO SHELF, PLACE MODULES IN THE 'LEFT' CHANNEL SIDE OF SHELF.
- 3. REFER TO FIGURE 1, SHEET 2, FOR SLIDE & CABLE ASSEMBLY.

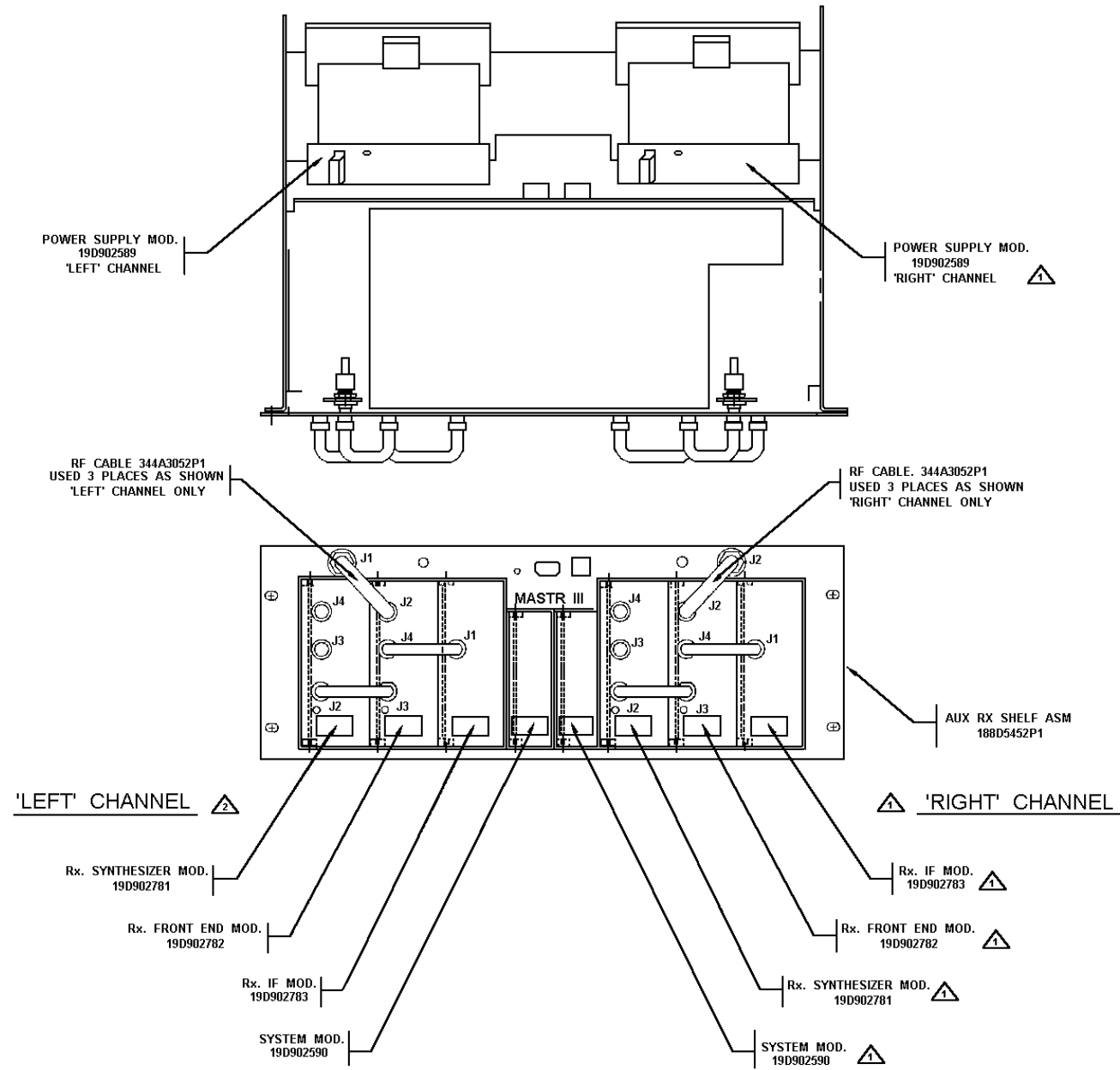

Assembly of Multiple Receiver Shelf For The MASTR III Indoor Cabinet 188D5450P1

(188D5450, Sheet 1, Rev. 2)

TOP VIEW, SHELF EXTENDED
MULTIPLE RECEIVER SHELF

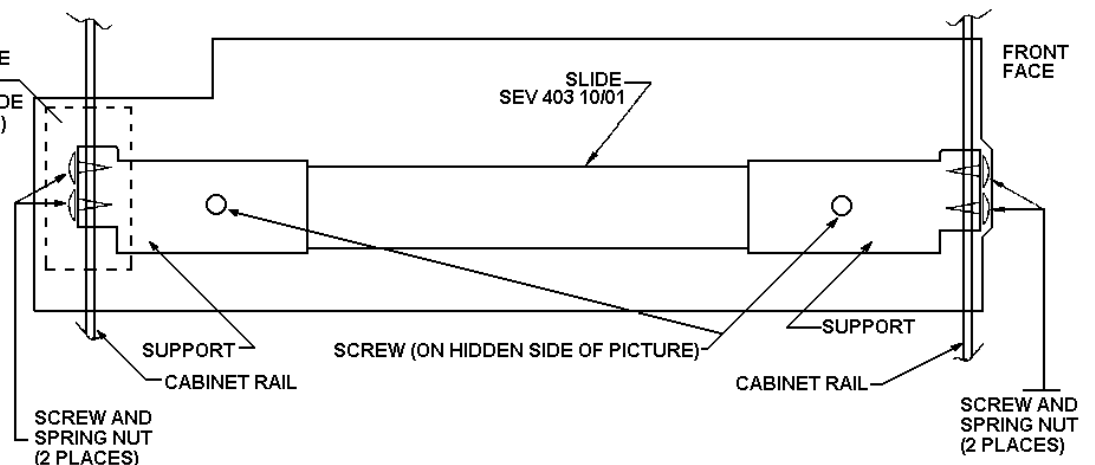
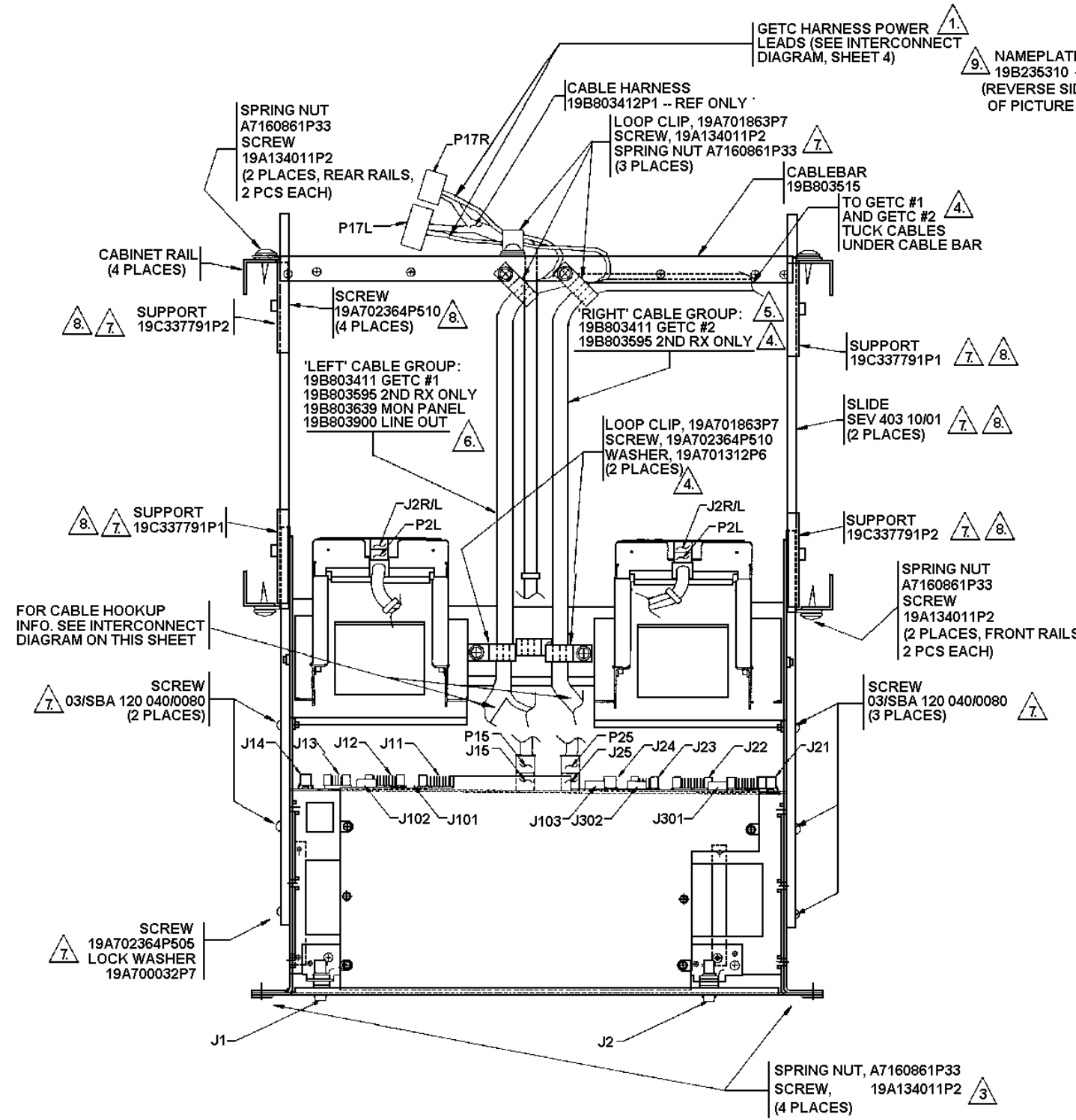

DETAIL - 1: SUPPORT & SLIDE PLACEMENT

FIGURE 1: RECEIVER SHELF

- NOTES:
- 1. INDIVIDUAL PINNED WIRES, OF HARNESS 19B803411, TO PLUG INTO P17 OF 19B803412P1 AT INDICATED PIN POSITIONS. ENSURE WIRES FROM 'LEFT' GETC HARNESS USED PINS #1 (RED) AND #5 (BLACK) WHILE WIRES FROM 'RIGHT' GETC HARNESS USE PINS #6 (BLACK) AND #10 (RED).
 - 2. J11 THRU J15 AND J21 THRU J25 ARE LOCATED ON THE BACKPLANE BOARD. J101, J102, J301, AND J302 ARE LOCATED ON THE INTERFACE BD.
 - 3. INDICATED NUTS & SCREWS TO SECURE SHELF TO CABINET FOR SHIPPING PURPOSES ONLY.
 - 4. FOR CONVENTIONAL, DELETE ALL GETC SHELVES AND HARDWARE.
 - 5. PRESENT ONLY IF 'RIGHT' SIDE OF AUX RX SHELF IS USED.
 - 6. BOTH LEFT & RIGHT SIGNALS RUN THRU THIS INDIVIDUAL CABLE.
 - 7. PART OF HARDWARE GROUP 350A1161.
 - 8. SEE DETAIL - 1 FOR SLIDE / SUPPORT ORIENTATION.
 - 9. PLACE NAMEPLATE FOR FIRST RECEIVER ON LEFT SIDE (PICTURED IN DETAIL-1). PLACE NAMEPLATE FOR SECOND RECEIVER ON RIGHT SIDE.

Assembly Of Multiple Receiver Shelf
For The MASTR III Indoor Cabinet

(188D5450, Sheet 2, Rev. 2)

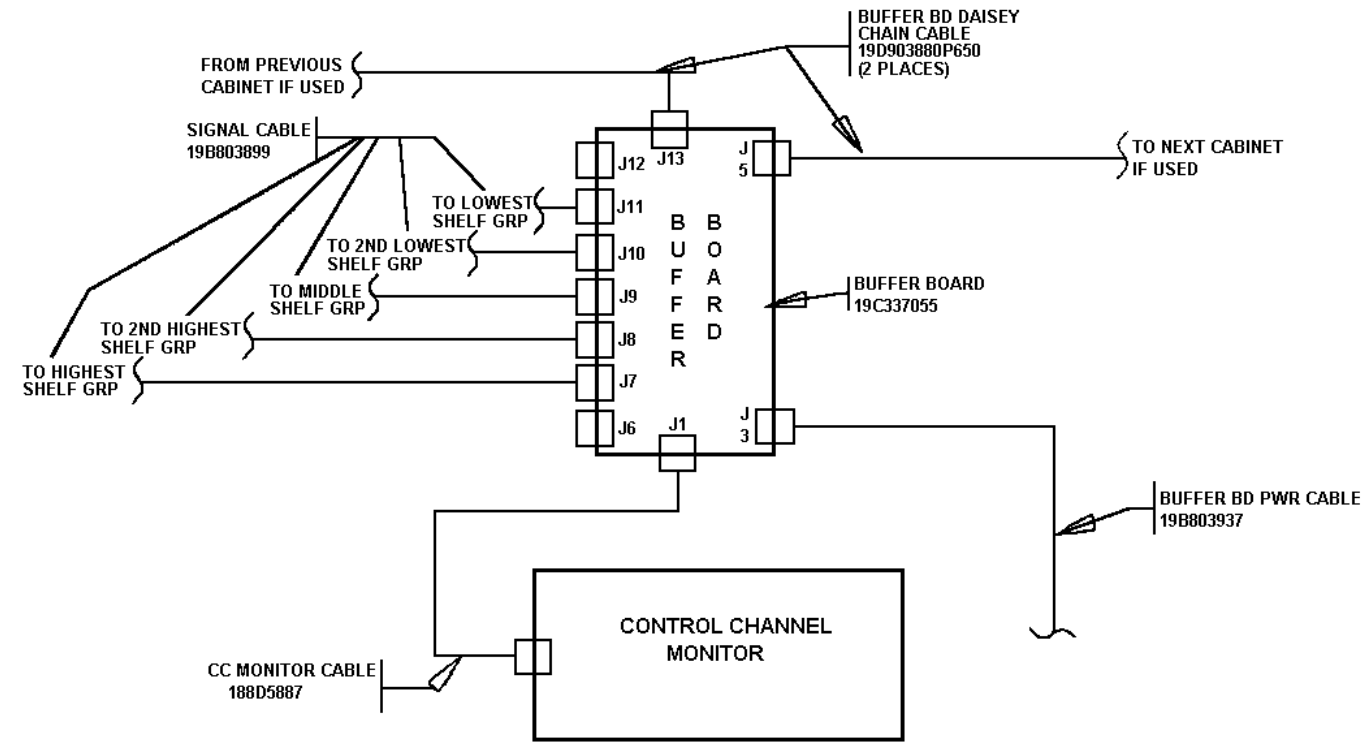
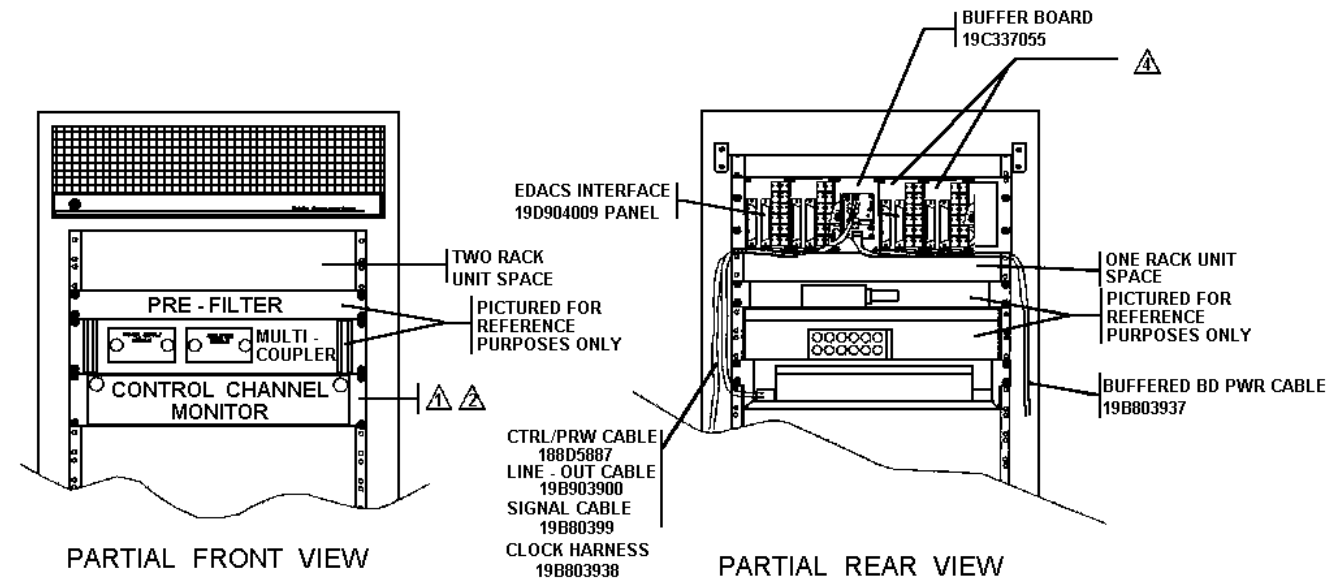

FIGURE 2:
BUFFER BOARD / CC MONITOR
INTERCONNECT DIAGRAM



CABINET VIEW OF BUFFER BOARD, SYSTEM PANEL, AND CC MONITOR

- 1. MOUNT CONTROL CHANNEL MONITOR (19D438294) IN THE 35TH & 36TH RACK UNITS (FROM THE BOTTOM) IN THE 83 INCH CABINET AND 86 INCH OPEN RACK.
- 2. MOUNT CONTROL CHANNEL MONITOR (19D438294) IN THE 27TH & 28TH RACK UNITS (FROM THE BOTTOM) IN THE 69 INCH CABINET.
- 3. SEE FIGURE 2 (THIS SHEET) FOR CABLE HOOKUP.
- 4. BOARDS ARE PRESENT ONLY IN SYNCHRONOUS RS-232 SYSTEMS.

Cabinet View Of Buffer Board, System Panel And Control Channel Monitor 188D5450P2

(188D5450, Sheet 3, Rev. 2)

EDACS - MULTIPLE RX SHELF WITH GETC (S)

CABINET VIEW OF MULTIPLE RECEIVER SHELF AND CORRESPONDING GETC SHELVES

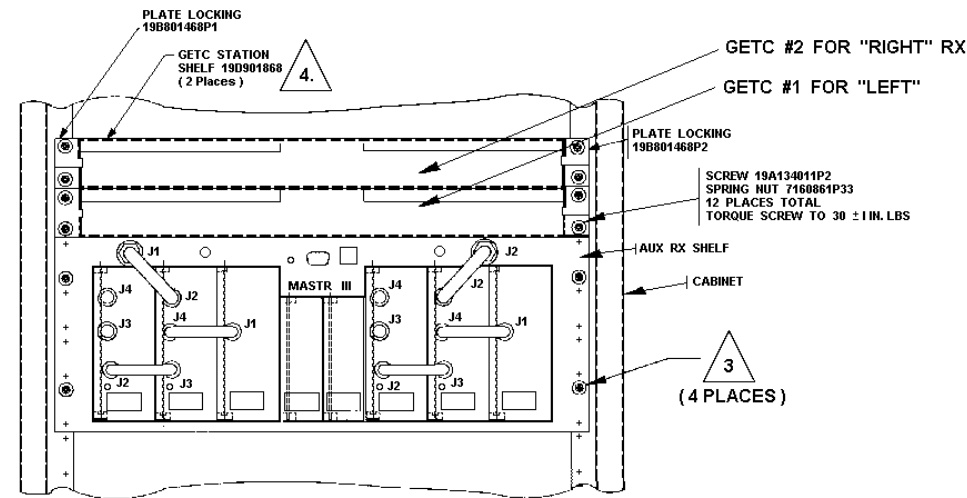

PARTIAL FRONT VIEW OF CABINET

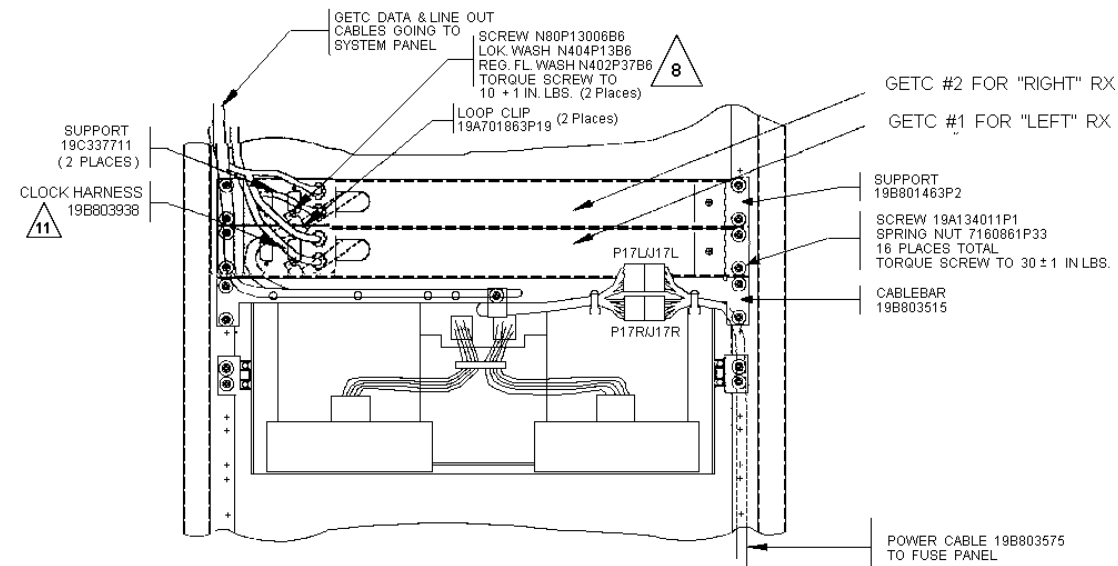

PARTIAL REAR VIEW OF CABINET

NOTES:

1. INDIVIDUAL PINNED WIRES OF HARNESS 19B803411, TO PLUG INTO P17L POSITION #1 (RED) & #5 (BLACK) IF GETC IS FOR "LEFT" AUX RX CHANNEL. OR INTO P17R POSITION #1 (RED) & #4 (BLACK) IF GETC IS FOR "RIGHT" AUX RX CHANNEL.
2. J11 THRU J15 AND J21 THRU J25 ARE LOCATED ON THE BACKPLANE BOARD. J101, J102, J301, AND J302 ARE LOCATED ON THE INTERFACE BD.
3. INDICATED NUTS & SCREWS TO SECURE SHELF TO CABINET FOR SHIPPING PURPOSES ONLY.
4. FOR CONVENTIONAL, DELETE ALL GETC SHELVES AND HARDWARE.
5. PRESENT ONLY IF "RIGHT" SIDE OF AUX RX SHELF IS USED.
6. BOTH LEFT AND RIGHT SIGNALS RUN THRU THIS INDIVIDUAL CABLE.
7. FOR SHELF RECEIVER SHELF DETAILS SEE FIGURE 1 ON SHEET 2.
8. ITEMS LOCATED BEHIND SUPPORT 19C337711
9. J31 ONLY EXISTS ON RS-232 OPTION.
10. REFER TO SHEET 5, FIGURE 3 FOR MORE GETC DETAILS.
11. REQUIRED FOR RS-232 SYSTEMS ONLY.

SHELF & GETC CONNECTION DIAGRAM

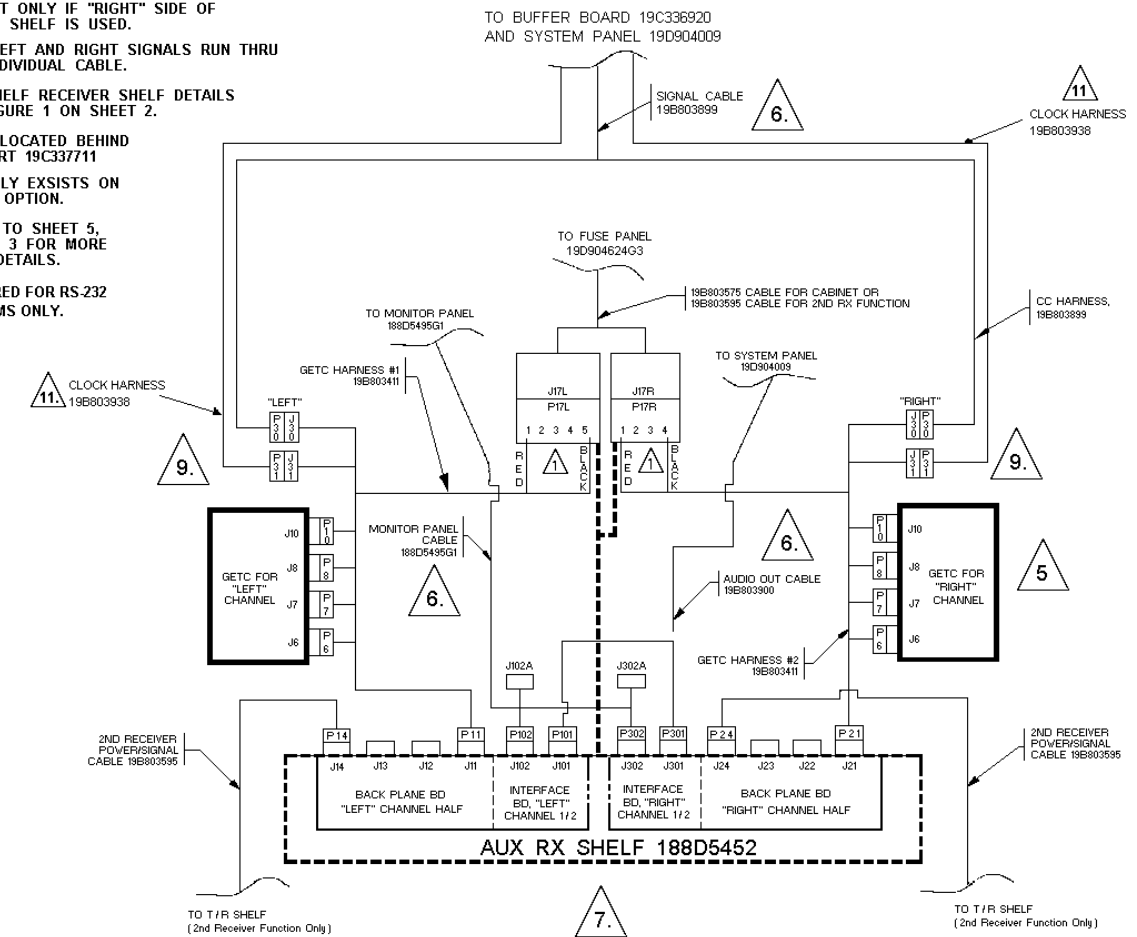

EDACS - Multiple Receiver Shelf with GETC's
188D5450P3

(188D5450, Sheet 4, Rev. 2)

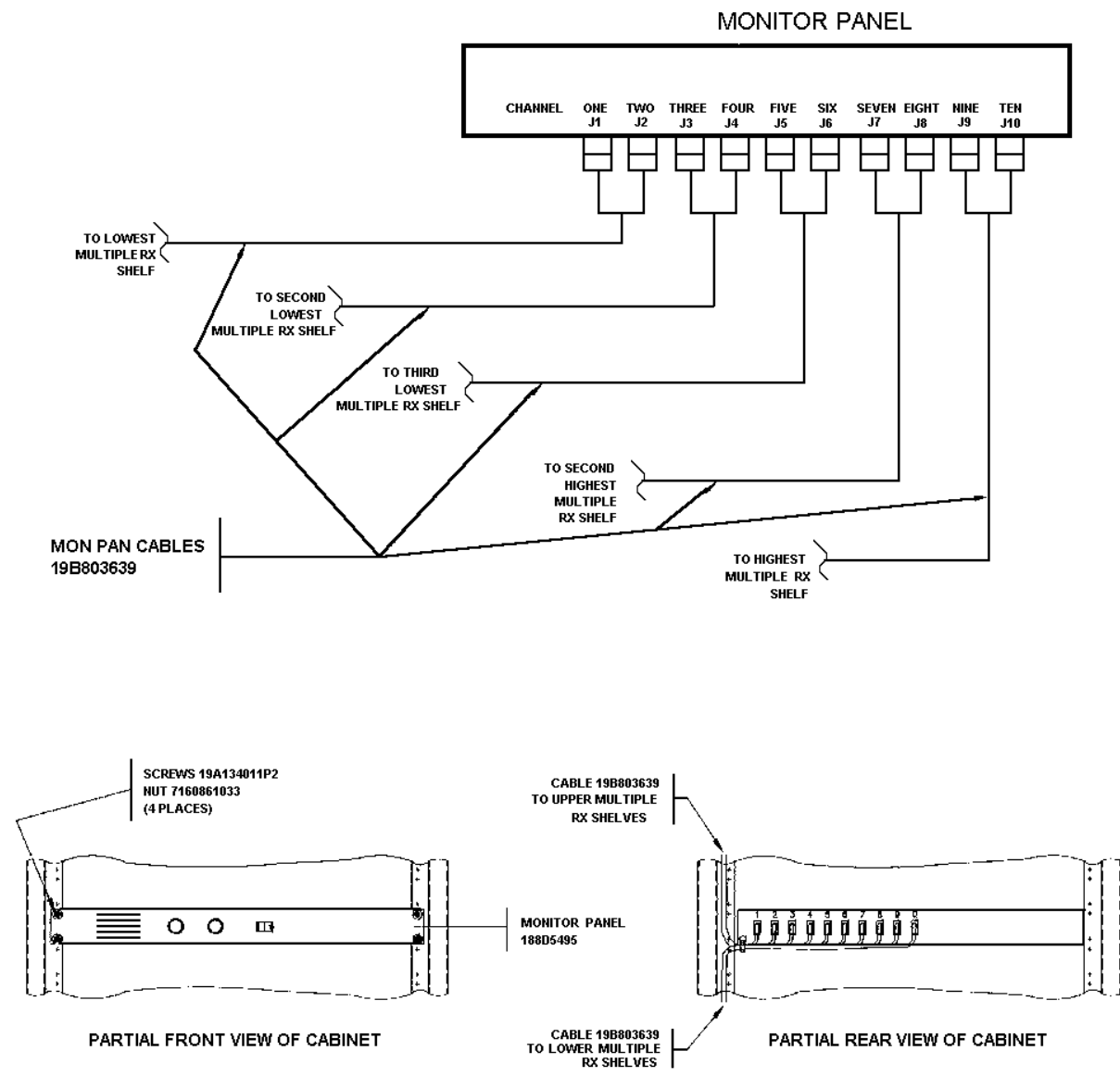

DETAIL B -- MONITOR PANEL

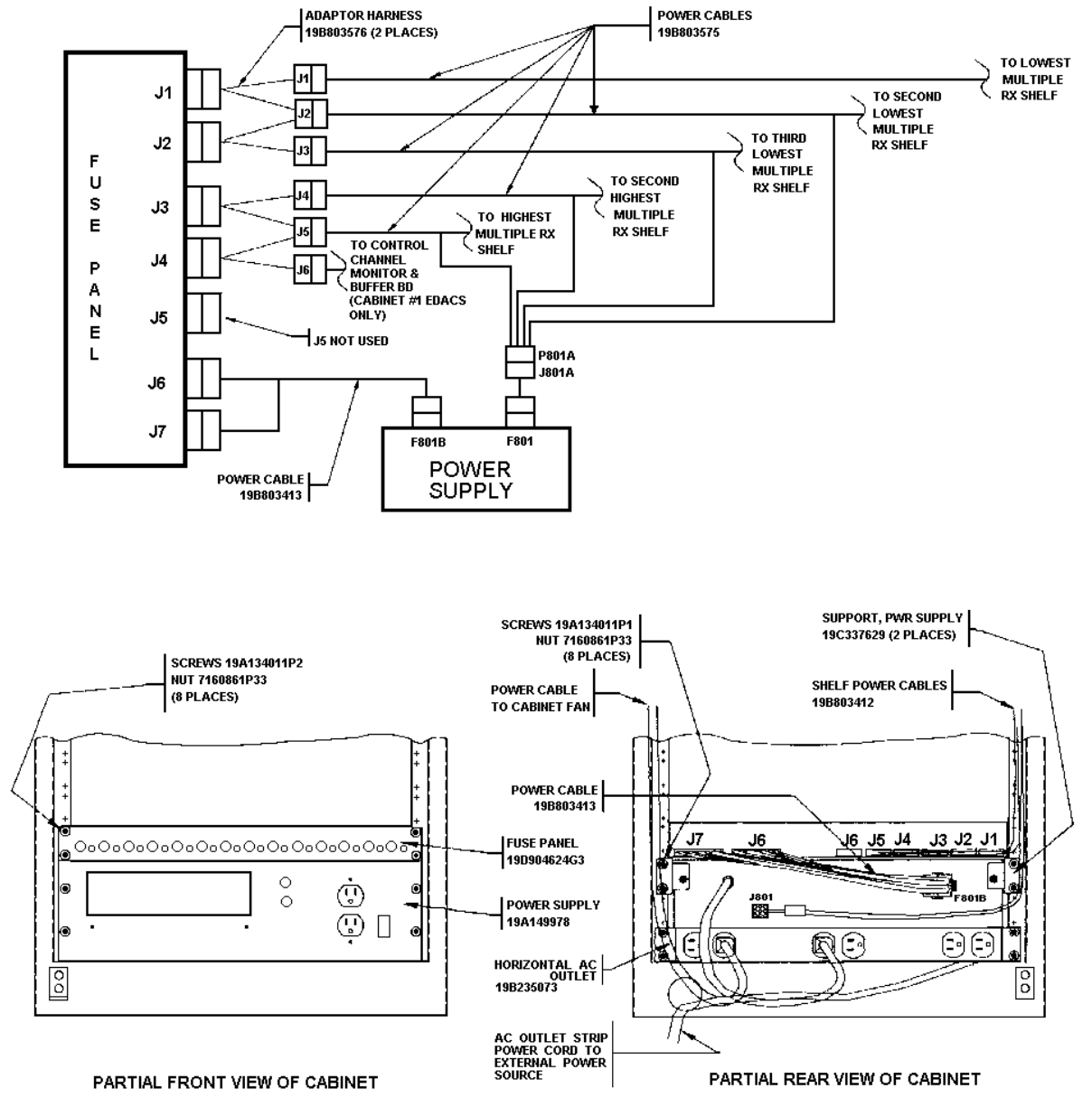

FIGURE 4 - POWER SUPPLY & FUSE PANEL

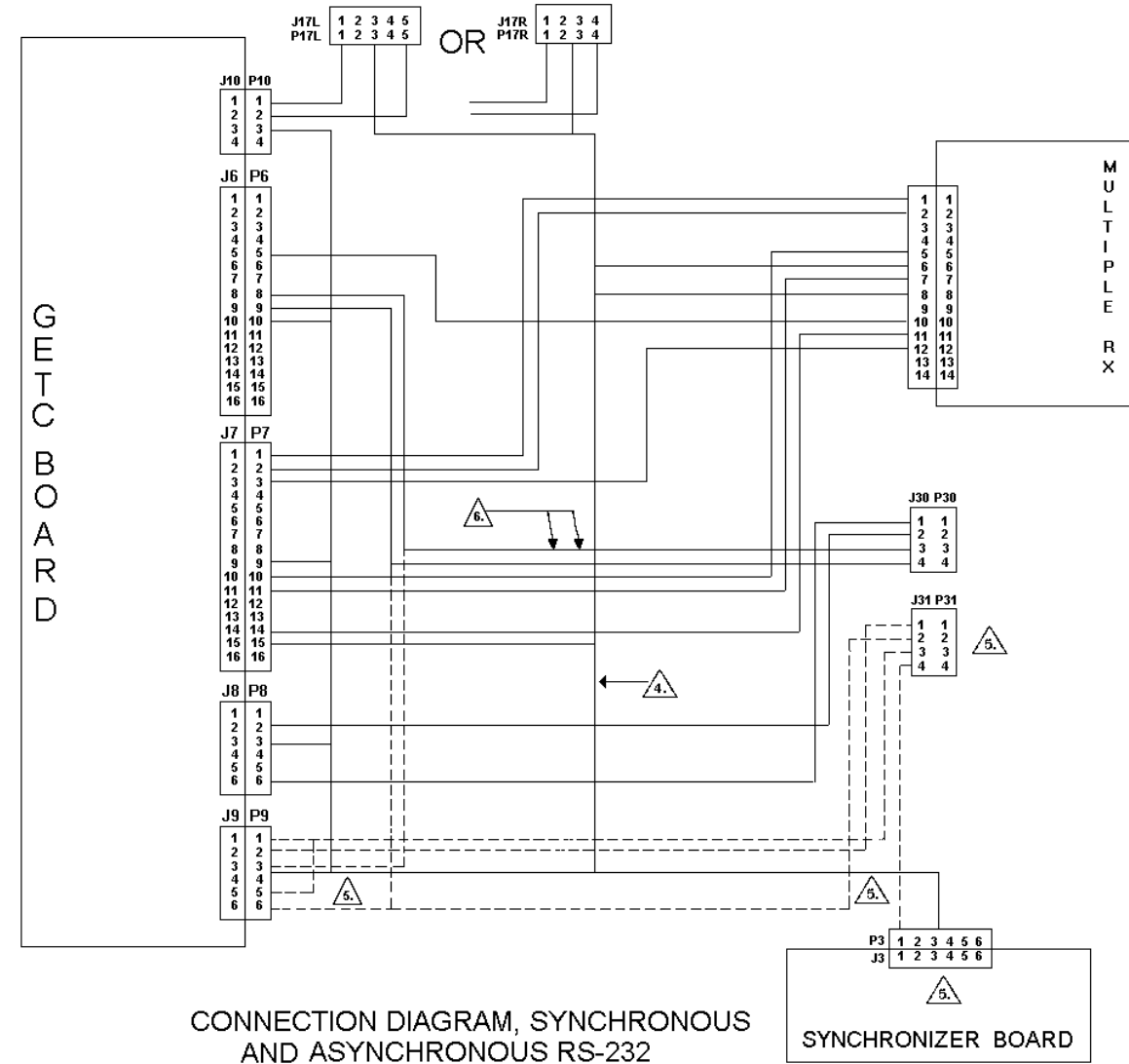
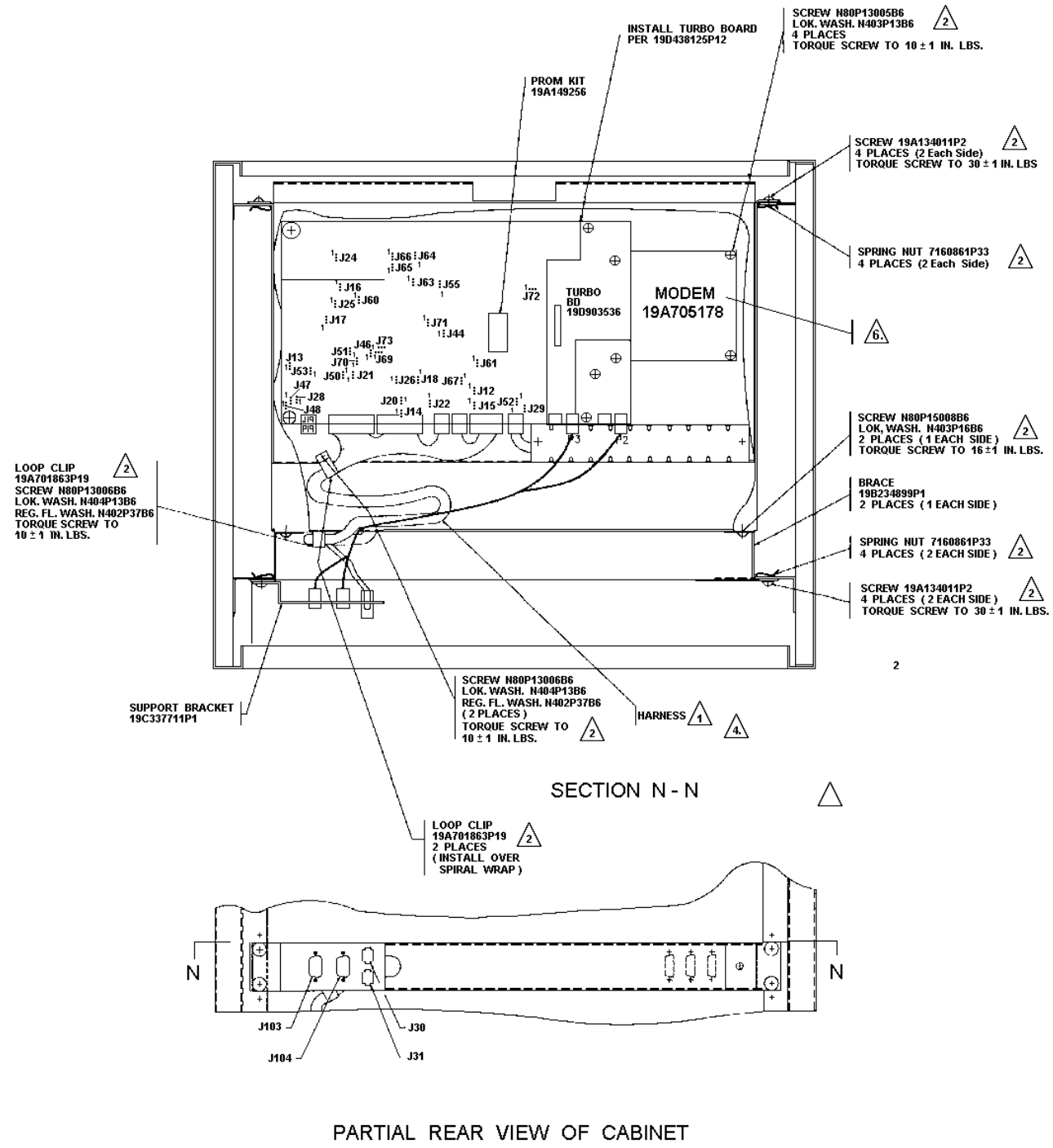

FIGURE 3: GETC SHELF MOUNTING IN STANDARD CABINET AND INTERCONNECT DIAGRAM.

- NOTES:
- INSTALL THE GETC SHELF 19D901868 AND HARNESS 19B803411 AS SHOWN AND INTERCONNECT IN ACCORDANCES WITH INTERCONNECT DIAGRAM 19D904268. INSTALL JUMPERS 19A702104P2 PER 349A9793P1.
 - ITEMS REFERENCING THIS CALLOUT ARE CALLED FOR ON HARDWARE KIT PL19A130031G30.
 - INTERCONNECT EDACS INTERFACE PANEL 19D904009 IN ACCORDANCE WITH INTERCONNECT DIAGRAM 19B06129. MOUNTING SCREWS AND SPRING NUTS ARE CALLED FOR IN HARDWARE KIT PL130031G30.
 - 19B803411P1 HARNESS USED WITH MODEM GETC OPTION, AND 19B803411P2 HARNESS USED WITH SYNCHRONOUS RS232 OPTION.
 - ALL DASHED LINE ARE ADDITIONAL LINES UTILIZED IN RS-232 / SIMULCAST GETC OPERATIONS.
 - SYNCHRONIZER BOARD REPLACES MODEM IN SYNCHRONOUS RS-232.

GETC Shelf Mounting In Standard Cabinet And Connection Diagram

(188D5450, Sheet 6, Rev. 2)

P10

FIRST CABINET OF AN EDACS MODEM AND ASYNCHRONOUS RS-232 SYSTEMS

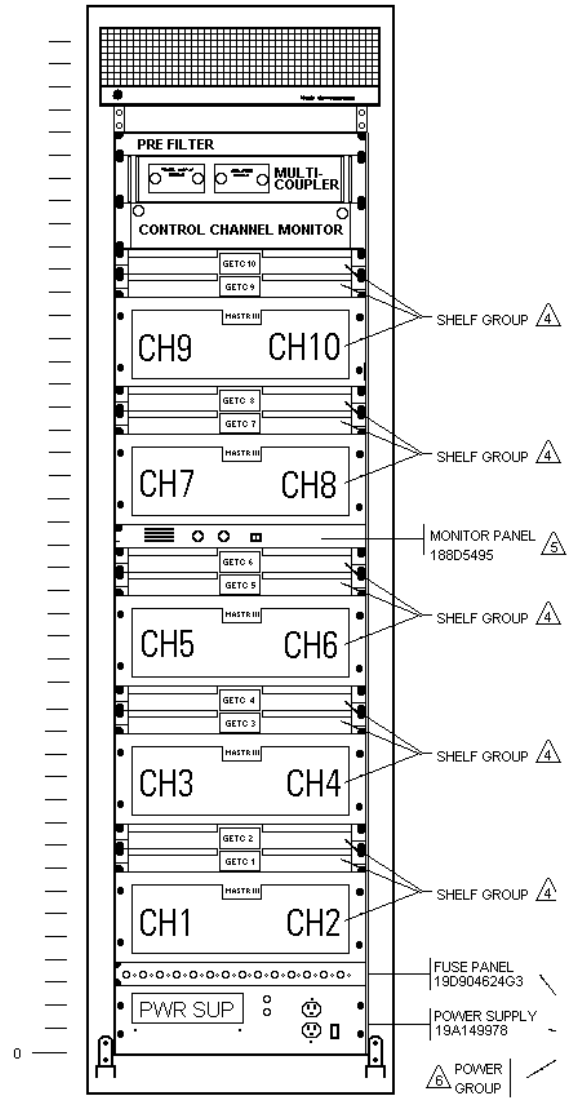

FRONT VIEW

P16

FIRST CABINET OF A SYNCHRONOUS RS-232 SYSTEM

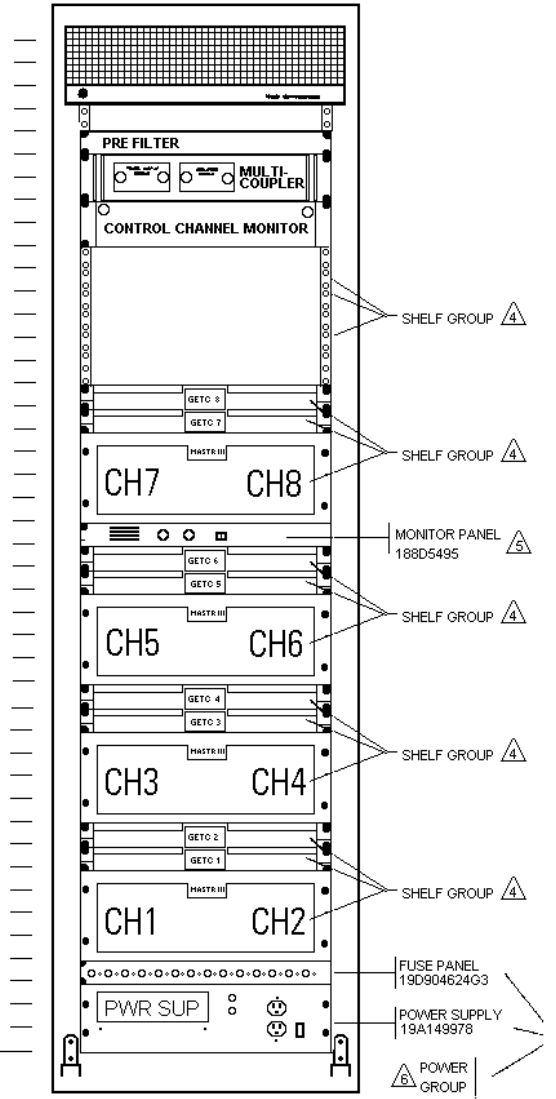

FRONT VIEW
(DOORS REMOVED FOR CLARITY)

P11

REMAINING CABINETS FOR EDACS MODEM, ASYNCHRONOL AND SYNCHRONOUS RS-232 SYSTEMS

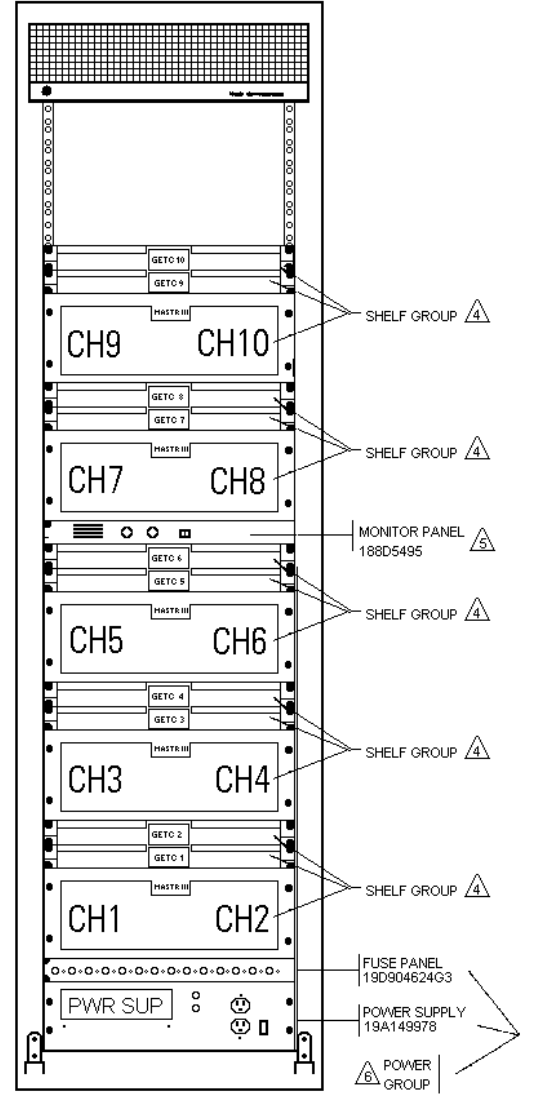

FRONT VIEW

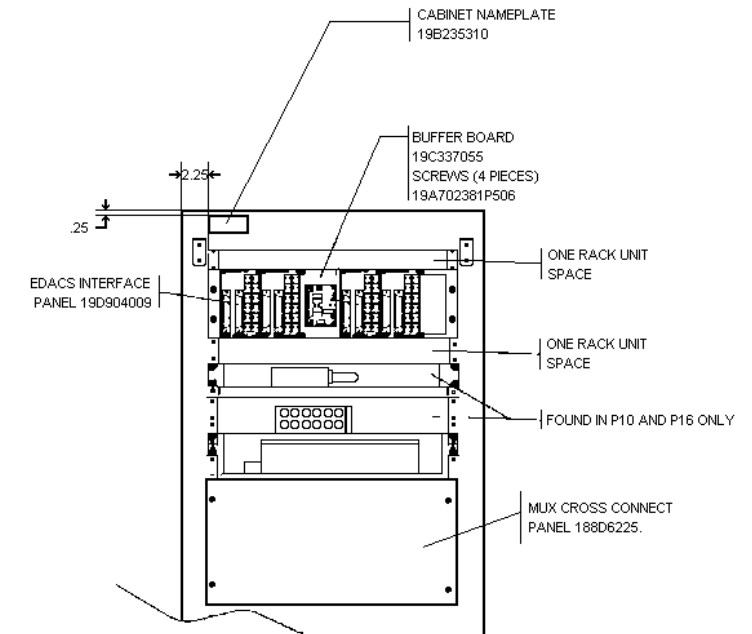

REAR VIEW, TOP OF ALL CABINETS

83" CABINET & 86" OPEN RACK

1. MOUNT SHELVES IN CABINET IN ASCENDING ORDER WITH LOWEST CHANNEL IN THE BOTTOM POSITION.
 2. TIE STRAP CABLES TO MOUNTING RAILS.
 3. AS VIEWED FROM THE REAR OF CABINET, RUN POWER CABLES ON RIGHT SIDE OF CABINETS AND SIGNAL CABLES ON THE LEFT SIDE OF CABINETS.
- ⚠️ SEE 188D5450 FIGURE 1 ON SHEET 2 AND 188D5450P3 ON SHEET 4 FOR SHELF GROUP MOUNTING AND CABLE HOOKUP.
 - ⚠️ SEE 188D5450P4 ON SHEET 6 FOR MONITOR PANEL MOUNTING AND CABLE HOOKUP.
 - ⚠️ SEE 188D5450 FIGURE 4 ON SHEET 6 FOR POWER GROUP MOUNTING AND CABLE HOOKUP.
 - 7. REFER TO 188D6129 FOR CABINET INTERCONNECT DIAGRAM.
 - ⚠️ SIX RACK UNITS LEFT EMPTY FOR DROP SHIPPED ITEMS (ONE OR TWO MUX SHELVES)

83" Cabinet & 86" Open Rack
188D5450P10, P11, P16

(188D5450, Sh. 7, Rev. 2)

P12

FIRST CABINET OF AN EDACS MODEM AND ASYNCHRONOUS RS-232 SYSTEMS

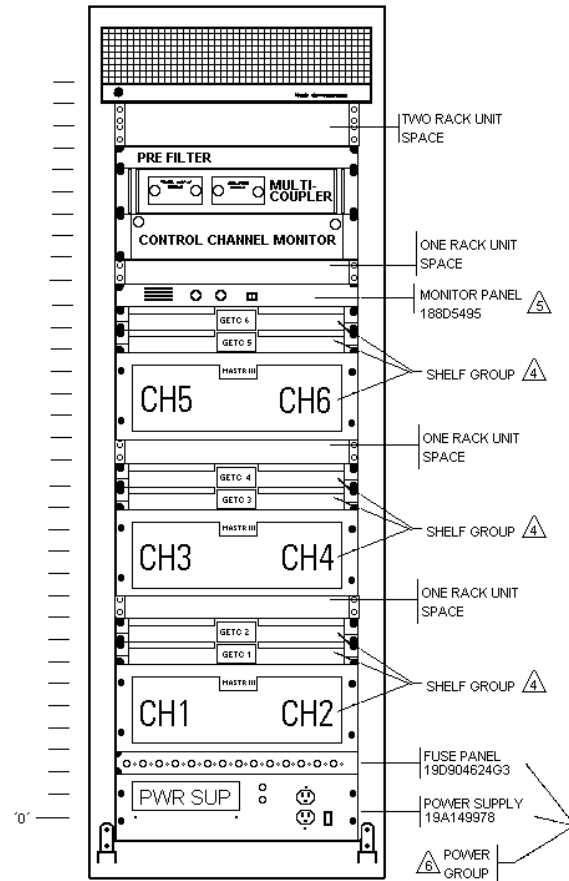

FRONT VIEW

P17

FIRST CABINET OF A SYNCHRONOUS RS-232 SYSTEM

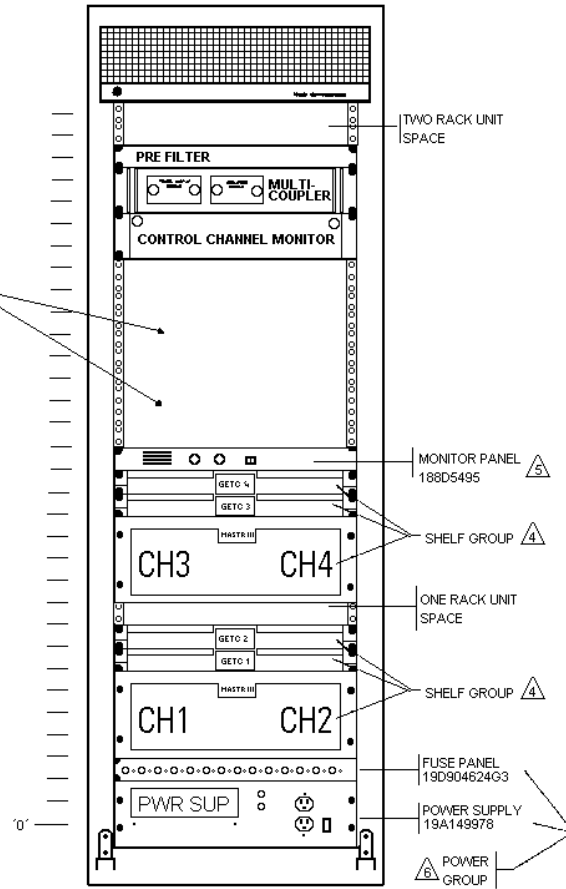

FRONT VIEW

P13

EXPANSION CABINETS FOR EDACS MODEM, ASYNCHRONOUS AND SYNCHRONOUS RS-232 SYSTEMS

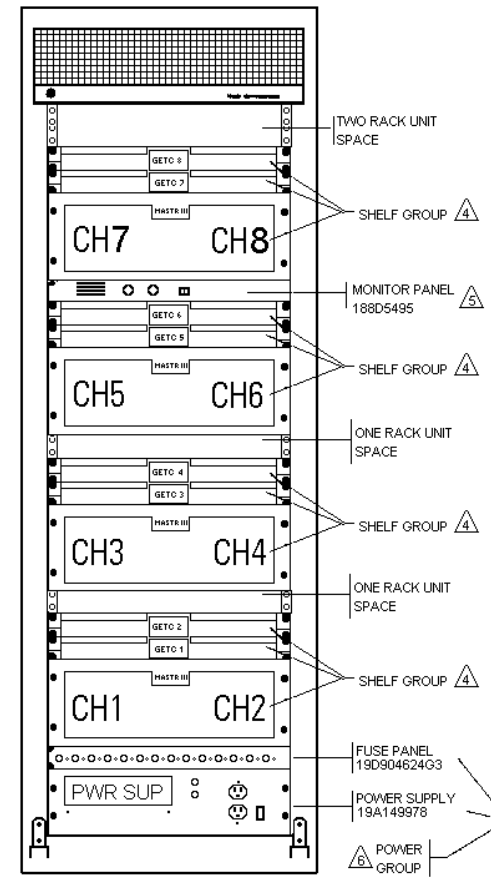

FRONT VIEW

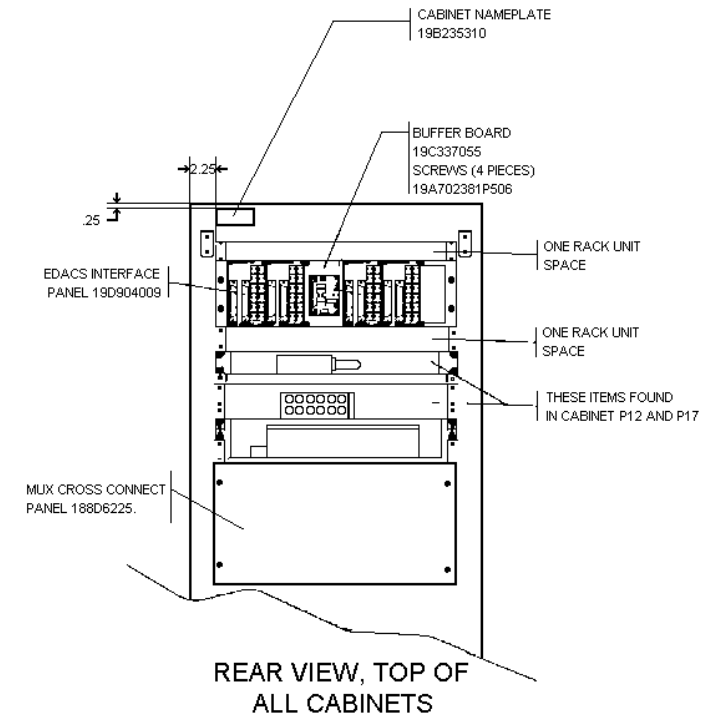

REAR VIEW, TOP OF ALL CABINETS

1. MOUNT STATIONS IN CABINET IN ASCENDING ORDER WITH LOWEST CHANNEL IN THE BOTTOM POSITION.
2. TIE STRAP CABLES TO MOUNTING RAILS.
3. INSTALL POWER CABLES AS SHOWN AND CONNECT IN ACCORDANCE WITH CONNECTION DIAGRAMS NOTED BELOW.
4. SEE 188D5450 FIGURE 1 ON SHEET 2 AND 188D5450P3 ON SHEET 4 FOR SHELF GROUP MOUNTING AND CABLE HOOKUP.
5. SEE 188D5450P4 ON SHEET 6 FOR MONITOR PANEL MOUNTING AND CABLE HOOKUP.
6. SEE 188D5450 FIGURE 4 ON SHEET 6 FOR POWER GROUP MOUNTING AND CABLE HOOKUP.
7. REFER TO 188D6129 FOR CABINET INTERCONNECT DIAGRAM.
8. SIX RACK UNITS LEFT EMPTY FOR DROP SHIPPED ITEMS (ONE OR TWO MUX SHELVES)

69" CABINETS
(DOORS REMOVED FOR CLARITY)

69" Cabinet
188D5450P12, P13, P17

(188D5450, Sh. 8, Rev. 2)

P15 CONVENTIONAL 83" CABINET

P14 CONVENTIONAL 69" CABINET

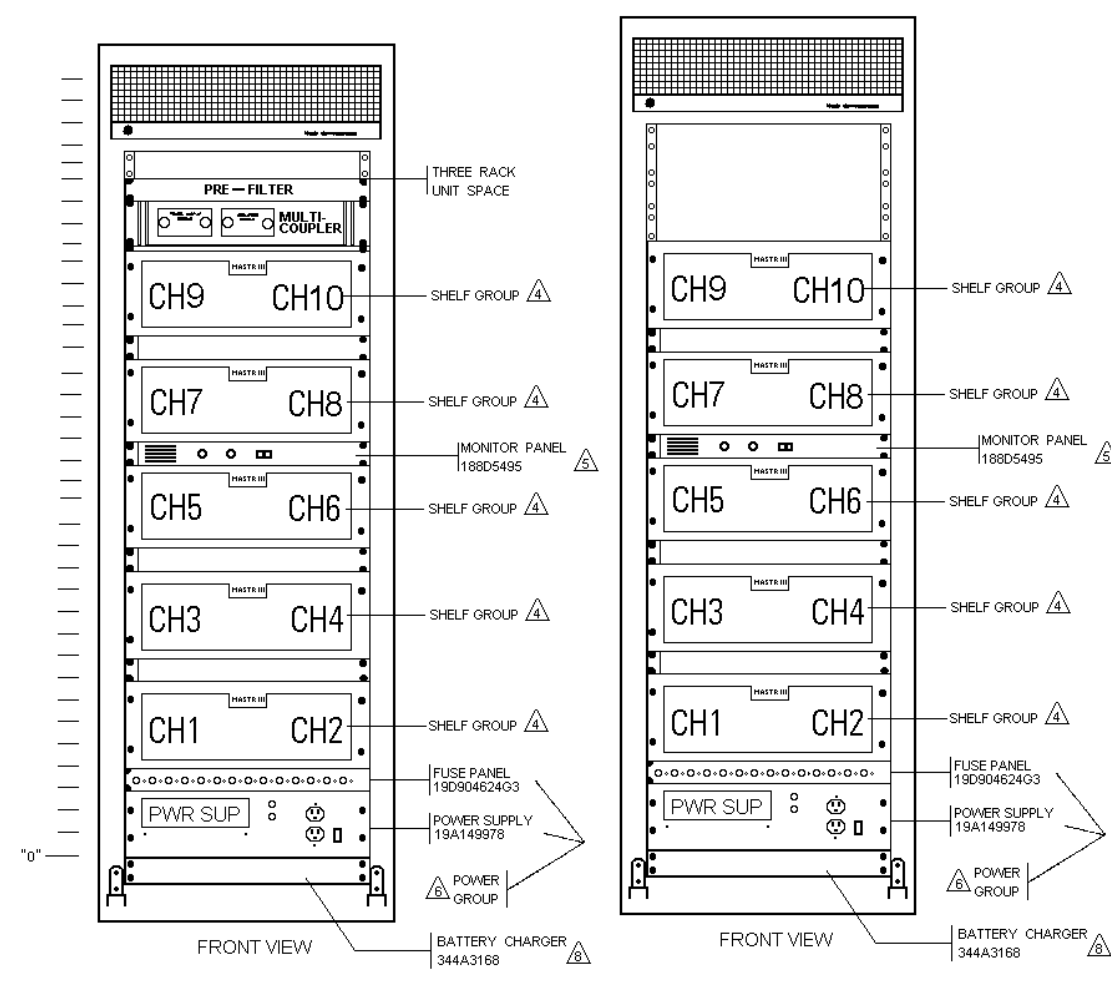

(DOORS REMOVED FOR CLARITY)

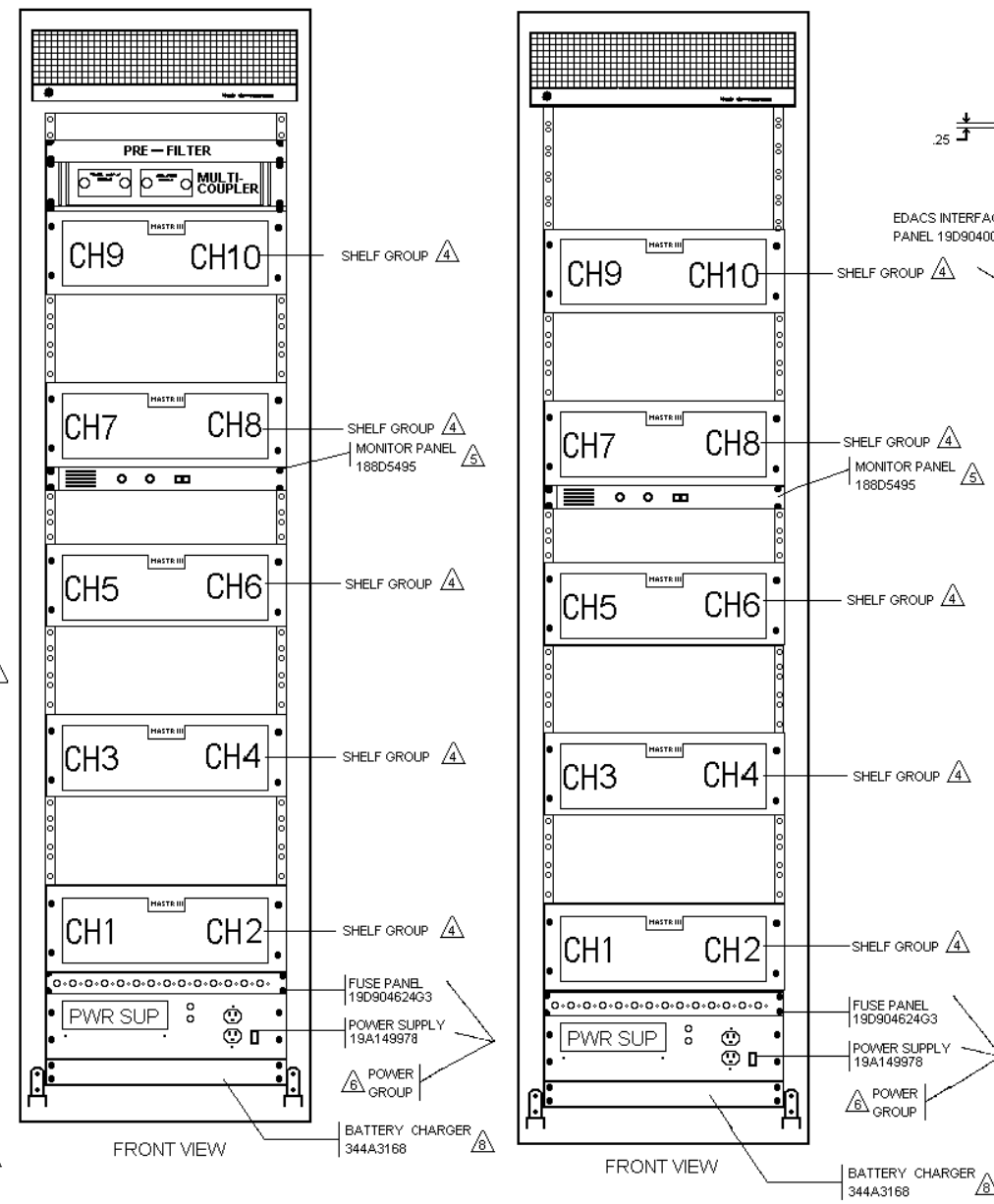

(DOORS REMOVED FOR CLARITY)

REAR VIEW, TOP OF CABINET #1 AND #2

1. MOUNT SHELVES IN CABINET IN ASCENDING ORDER WITH LOWEST CHANNEL IN THE BOTTOM POSITION.
 2. TIE STRAP CABLES TO MOUNTING RAILS.
 3. INSTALL POWER CABLES AS SHOWN AND CONNECT IN ACCORDANCE WITH CONNECTION DIAGRAMS NOTED BELOW.
- ⚠ SEE 188D5450 FIGURE 1 ON SHEET 2 AND 188D5450P3 ON SHEET 4 FOR SHELF GROUP MOUNTING AND CABLE HOOKUP.
 - ⚠ SEE 188D5450P4 ON SHEET 6 FOR MONITOR PANEL MOUNTING AND CABLE HOOKUP.
 - ⚠ SEE 188D5450 FIGURE 4 ON SHEET 6 FOR POWER GROUP MOUNTING AND CABLE HOOKUP.
 - 7. REFER TO 188D6129 FOR CABINET INTERCONNECT DIAGRAMS.
 - ⚠ SEE 188D5450 FIGURE 5 ON SHEET 11 FOR BATTERY BACKUP INTERCONNECT AND CABLING.

69" & 83" Conventional Cabinet
188D5450P14 & P15

(188d5450, Sh. 9, Rev. 2)

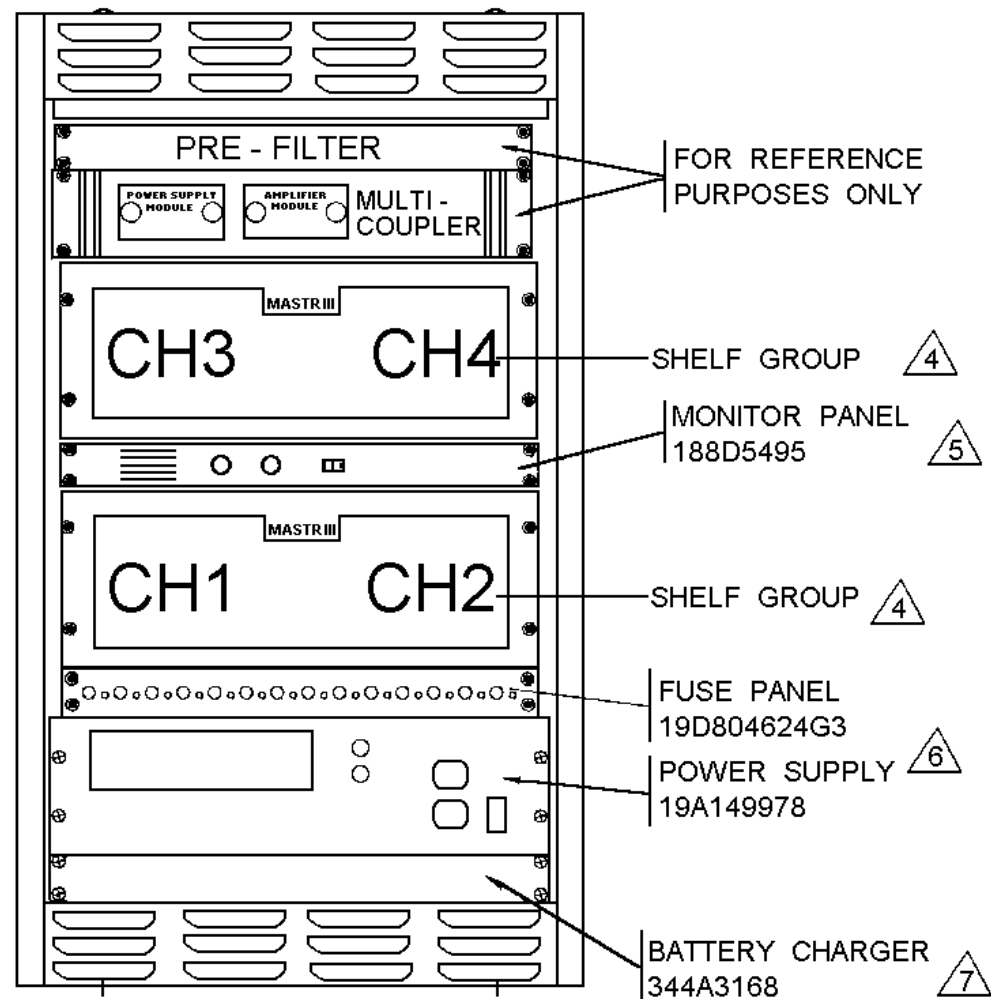

FRONT VIEW

ASSEMBLY OF MULTIPLE RX SHELF FOR THE 37" MASTR III INDOOR CABINET APPLICATION.

- 4 SEE 188D5450 FIGURE 1 ON SHEET 2 AND 188D5450P3 ON SHEET 4 FOR SHELF GROUP MOUNTING AND CABLE HOOKUP (IGNORE GETC REFERENCES.)
- 5 SEE 188D5450P4 ON SHEET 6 FOR MONITOR PANEL MOUNTING AND CABLE HOOKUP.
- 6 SEE 188D5450 FIGURE 4 ON SHEET 6 FOR POWER GROUP MOUNTING AND CABLE HOOKUP.
- 7 SEE 188D5450 FIGURE 5 ON SHEET 11 FOR BATTERY BACKUP INTERCONNECT AND CABLING.

**Multiple Receiver Shelf
37" MASTR III Indoor Cabinet
188D5450P5**

(188d5450, Sh. 10, Rev. 2)

EDACS MODEM OR ASYNCHRONOUS RS-232 SYSTEM IN 83" CABINETS OR 86" OPEN RACKS

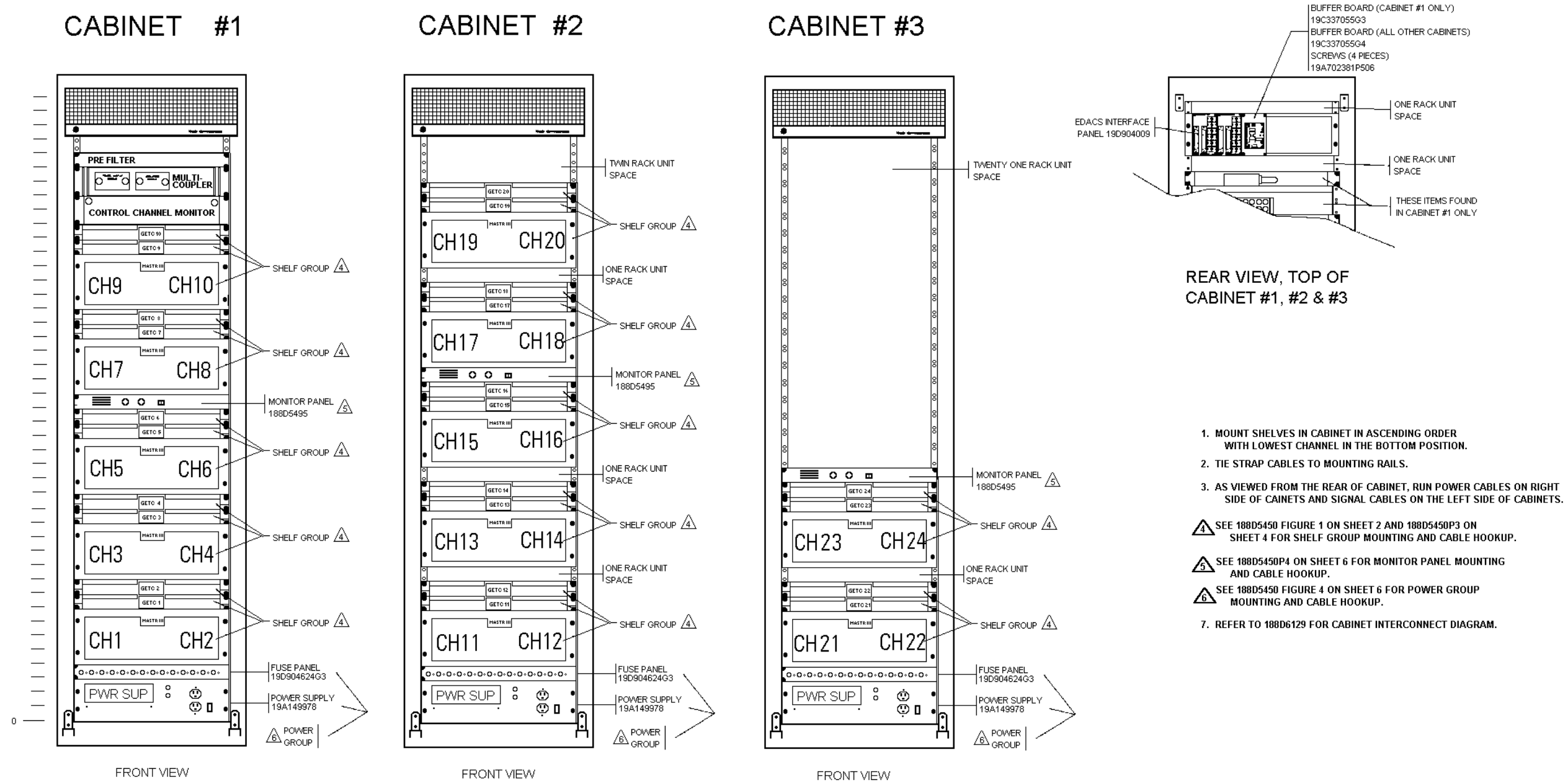

EDACS Modem or Asynchronous RS-232
83" Cabinet or 86" Open Rack

(188D5450, Sheet 7, Rev. 1)

EDACS MODEM OR ASYNCHRONOUS RS-232 SYSTEM IN 69" CABINETS

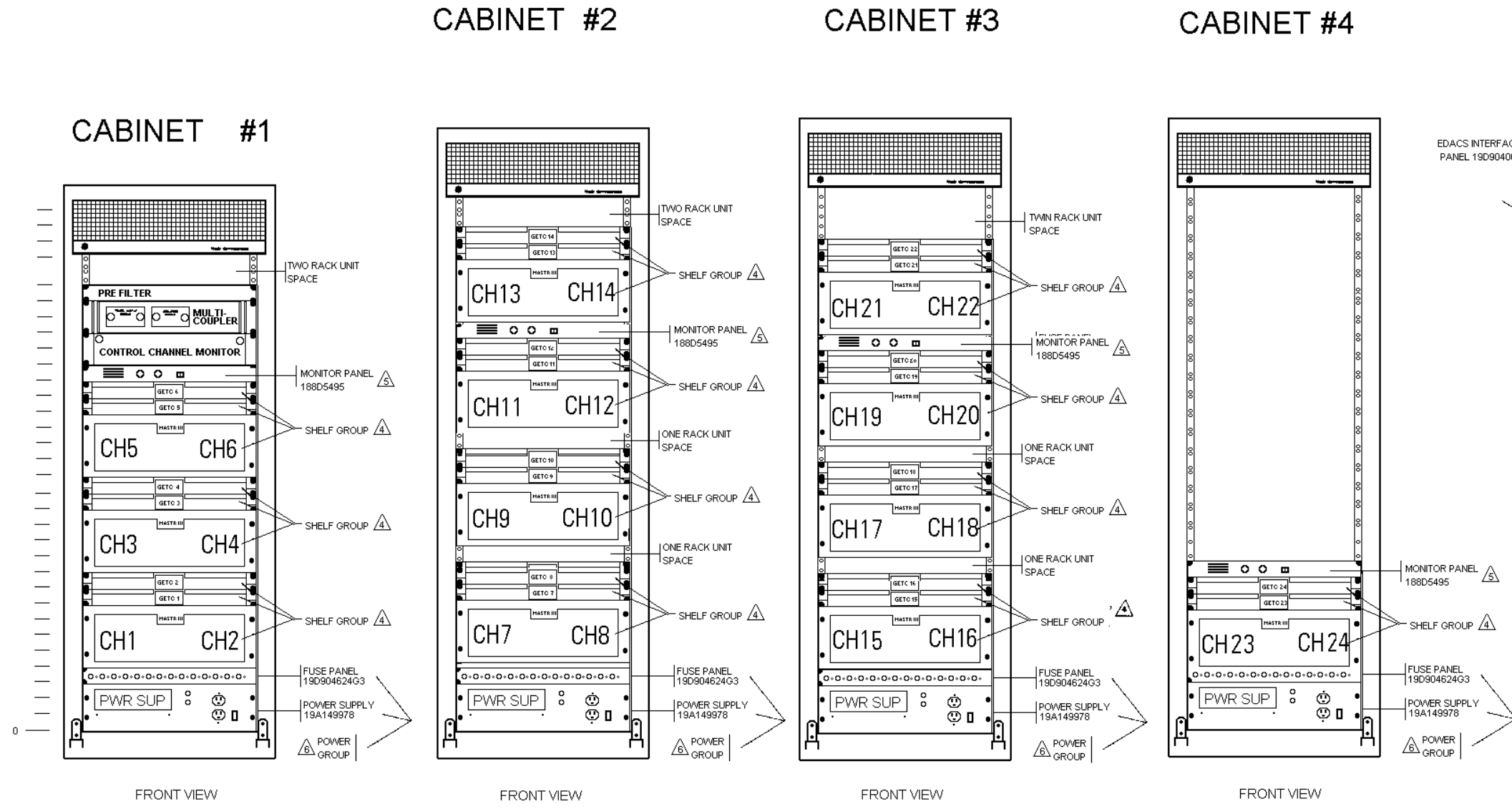

(DOORS REMOVED FOR CLARITY)

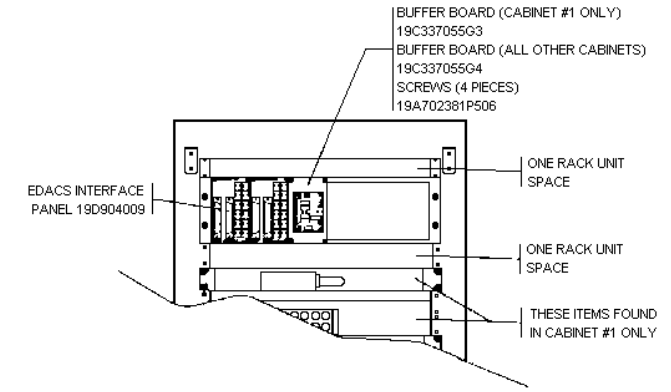

REAR VIEW, TOP OF CABINET #1, #2 & #3

1. MOUNT STATIONS IN CABINET IN ASCENDING ORDER WITH LOWEST CHANNEL IN THE BOTTOM POSITION.
2. TIE STRAP CABLES TO MOUNTING RAILS.
3. INSTALL POWER CABLES AS SHOWN AND CONNECT IN ACCORDANCE WITH CONNECTION DIAGRAMS NOTED BELOW.
4. SEE 188D5450 FIGURE 1 ON SHEET 2 AND 188D5450P3 ON SHEET 4 FOR SHELF GROUP MOUNTING AND CABLE HOOKUP.
5. SEE 188D5450P4 ON SHEET 6 FOR MONITOR PANEL MOUNTING AND CABLE HOOKUP.
6. SEE 188D5450 FIGURE 4 ON SHEET 6 FOR POWER GROUP MOUNTING AND CABLE HOOKUP.
7. REFER TO 188D6129 FOR CABINET INTERCONNECT DIAGRAM.

EDACS Modem or Asynchronous RS-232 69" Cabinet

(188D5450, Sheet 8, Rev. 1)

SYNCHRONOUS RS-232 SYSTEM IN 83" CABINETS OR 86" OPEN RACKS

CABINET #1

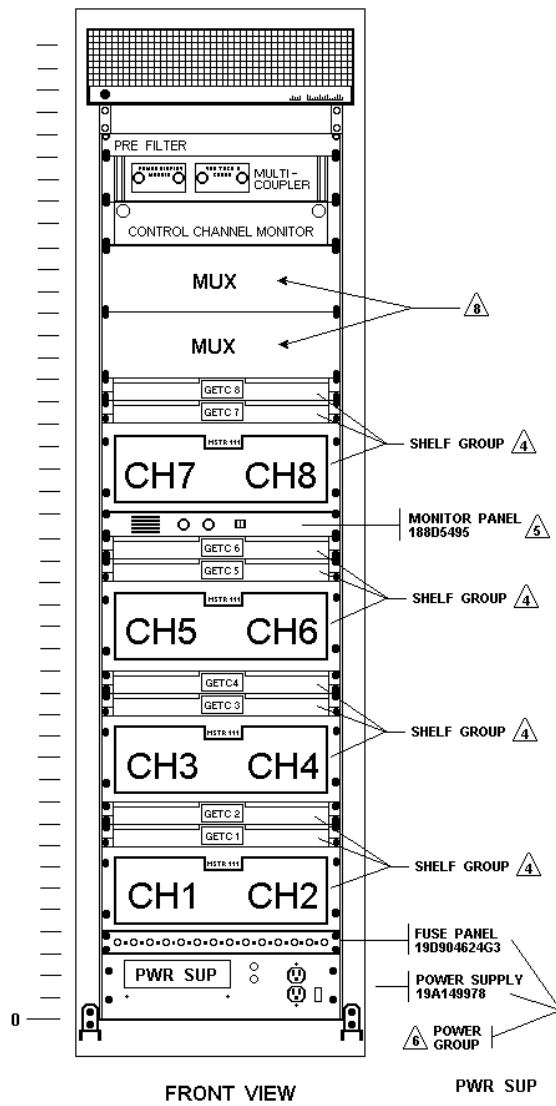

CABINET #2

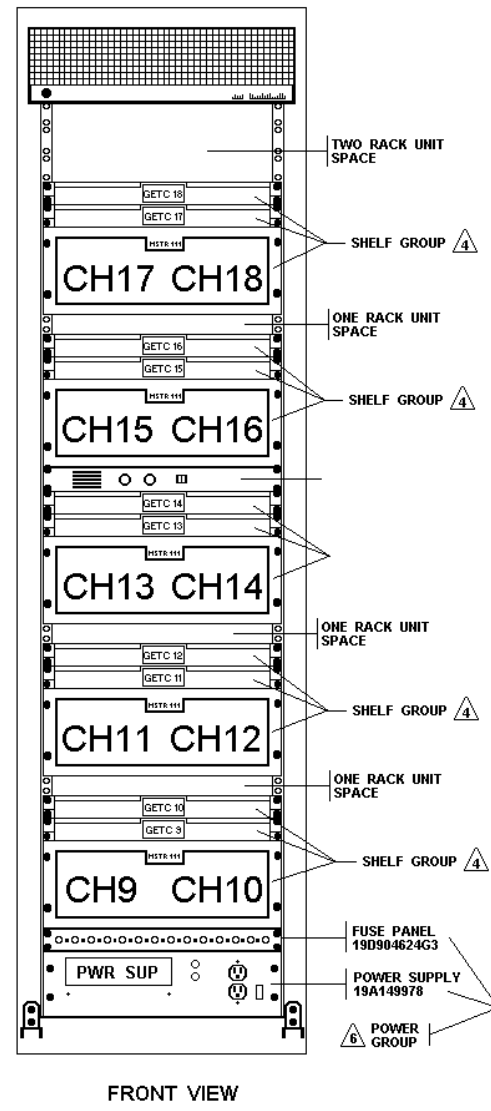

CABINET #3

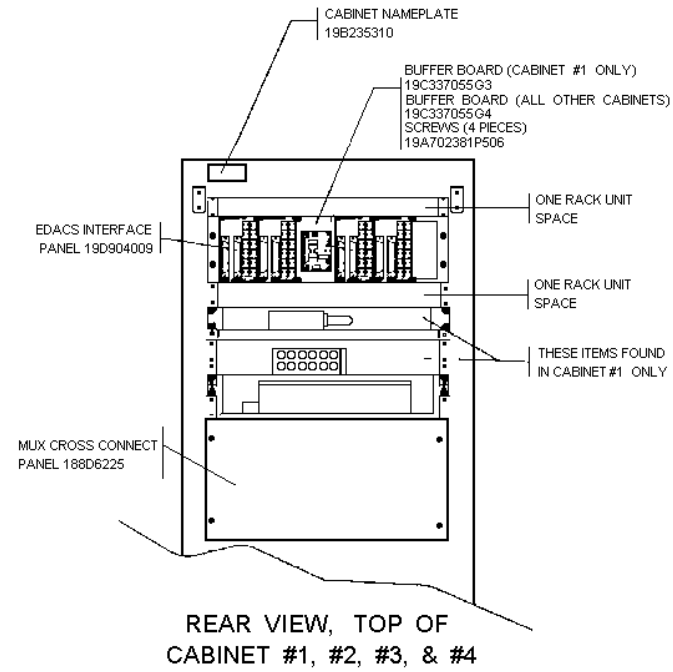
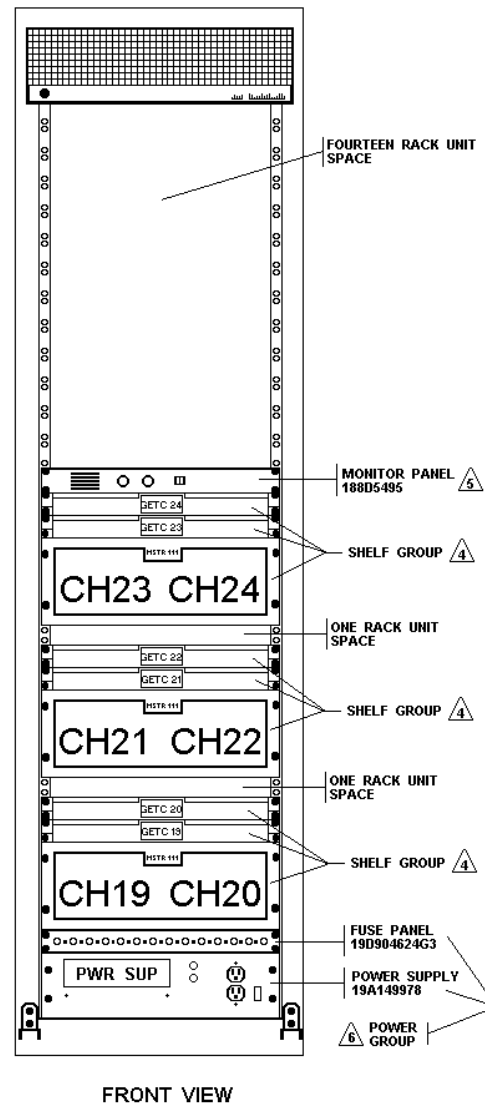

1. MOUNT STATIONS IN CABINET IN ASCENDING ORDER WITH LOWEST CHANNEL IN THE BOTTOM POSITION.
2. TIE STRAP CABLES TO MOUNTING RAILS.
3. INSTALL POWER CABLES AS SHOWN AND CONNECT IN ACCORDANCE WITH CONNECTION DIAGRAMS NOTED BELOW.
4. SEE 188D5450 FIGURE 1 ON SHEET 2 AND 188D5450P3 ON SHEET 4 FOR SHELF GROUP MOUNTING AND CABLE HOOKUP.
5. SEE 188D5450P4 ON SHEET 6 FOR MONITOR PANEL MOUNTING AND CABLE HOOKUP.
6. SEE 188D5450 FIGURE 4 ON SHEET 6 FOR POWER GROUP MOUNTING AND CABLE HOOKUP.
7. REFER TO 188D6129 FOR CABINET INTERCONNECT DIAGRAM.
8. SIX RACK UNITS LEFT EMPTY FOR DROP SHIPPED ITEMS (ONE OR TWO MUX SHELVES)

(DOORS REMOVED FOR CLARITY)

Synchronous RS-232 System, 83" Cabinet or 86" Open Rack

(RC-1, Rev. 1)

SYNCHRONOUS RS-232 SYSTEM IN 69" CABINETS

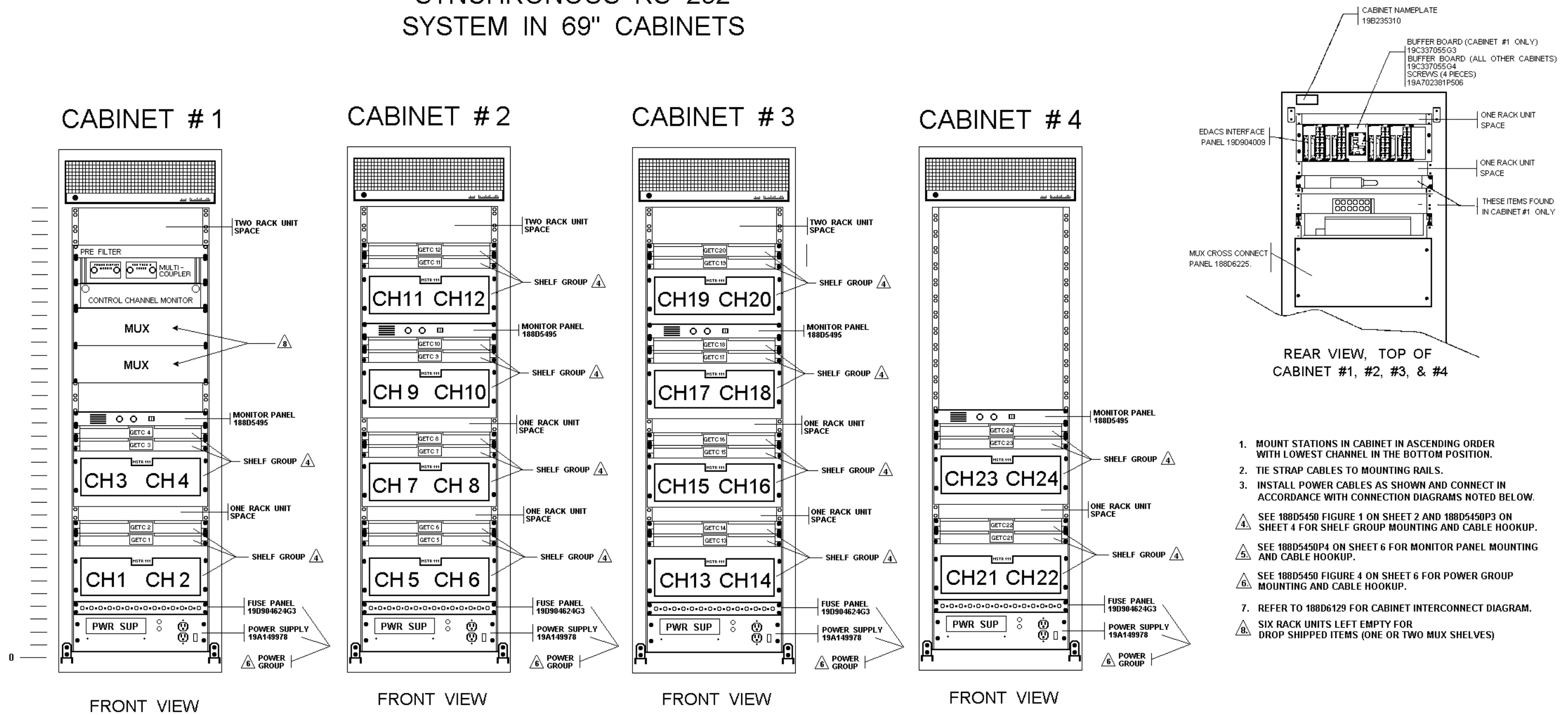

(DOORS REMOVED FOR CLARITY)

1. MOUNT STATIONS IN CABINET IN ASCENDING ORDER WITH LOWEST CHANNEL IN THE BOTTOM POSITION.
2. TIE STRAP CABLES TO MOUNTING RAILS.
3. INSTALL POWER CABLES AS SHOWN AND CONNECT IN ACCORDANCE WITH CONNECTION DIAGRAMS NOTED BELOW.
4. SEE 188D5450 FIGURE 1 ON SHEET 2 AND 188D5450P3 ON SHEET 4 FOR SHELF GROUP MOUNTING AND CABLE HOOKUP.
5. SEE 188D5450P4 ON SHEET 6 FOR MONITOR PANEL MOUNTING AND CABLE HOOKUP.
6. SEE 188D5450 FIGURE 4 ON SHEET 6 FOR POWER GROUP MOUNTING AND CABLE HOOKUP.
7. REFER TO 188D6129 FOR CABINET INTERCONNECT DIAGRAM.
8. SIX RACK UNITS LEFT EMPTY FOR DROP SHIPPED ITEMS (ONE OR TWO MUX SHELVES)

Synchronous RS-232 69" Cabinets

(RC-4, Rev. 1)

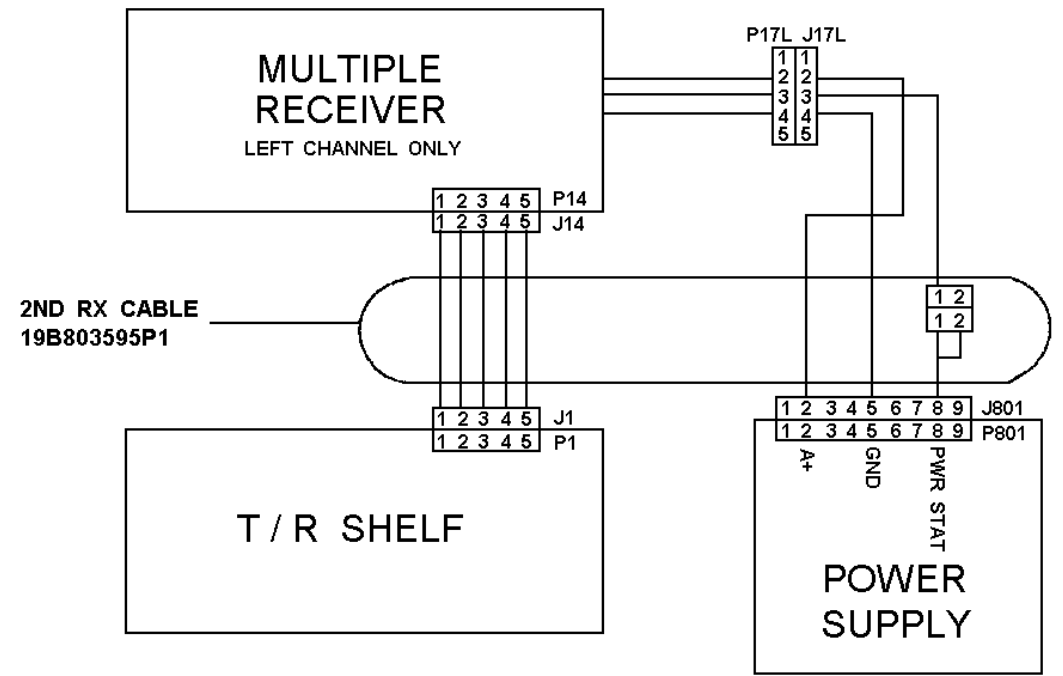
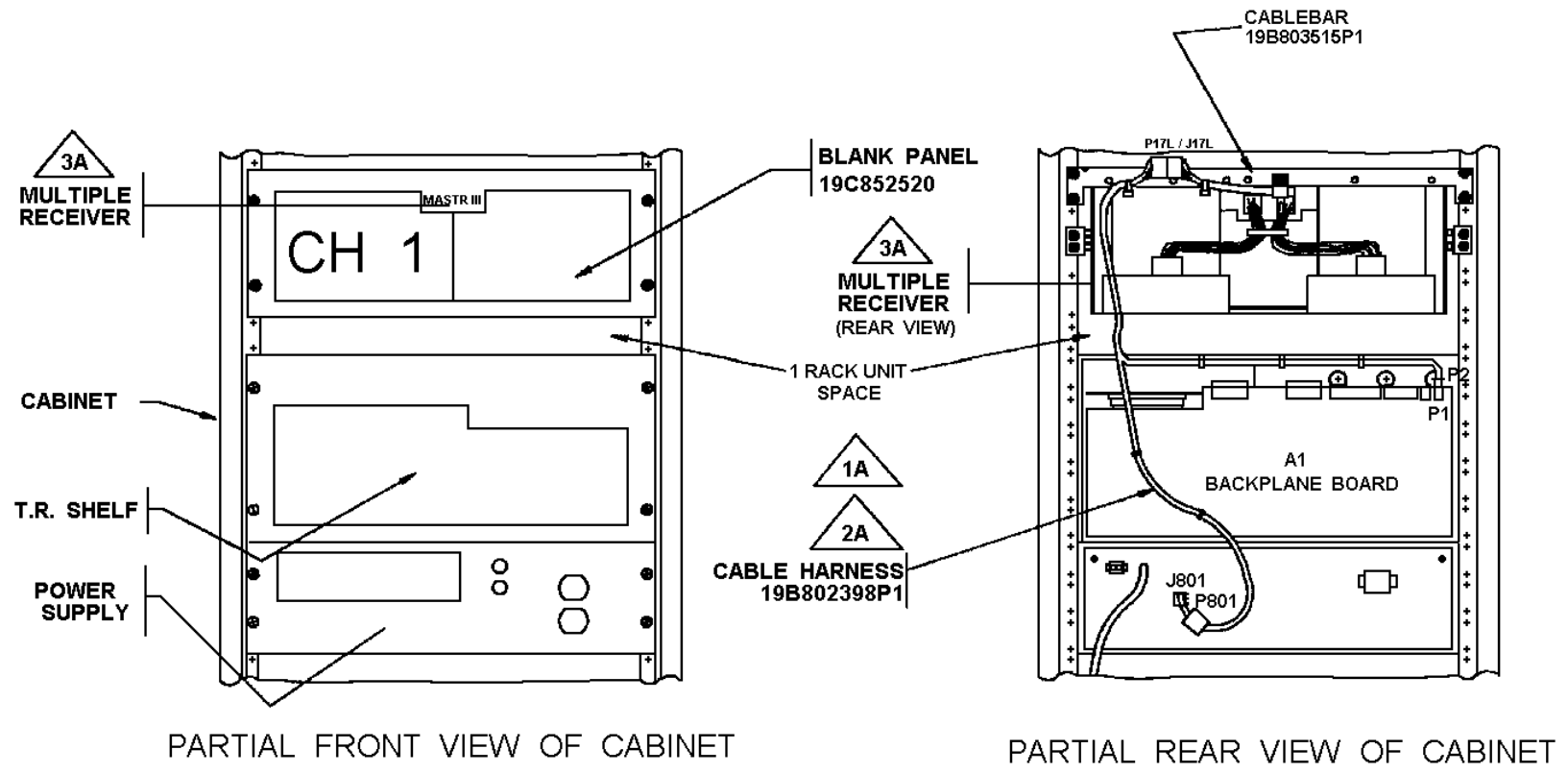

INTERCONNECT DIAGRAM FOR MULTIPLE RECEIVER IN 2ND RECEIVER FUNCTION

37 AND 69 INCH. HIGH INDOOR FIXED LAND CABINETS
MASTR III STATION WITH MASTR III MULTIPLE RECEIVER.

NOTES:

- ⚠️ INSTALL THE MULTIPLE RECEIVER SHELF AND CABLE HARNESS 19B802398P1 AS SHOWN. INTERCONNECT IN ACCORDANCE WITH INTERCONNECT DIAGRAM 19B802439.
- ⚠️ ITEMS REFERENCING THIS CALLOUT ARE CALLED FOR ON HARDWARE KIT PL344A3450G8.
- ⚠️ FOR RECEIVER MOUNTING INFORMATION, SEE 188D5450 SHEET 2, FIG. 1.

Second Receiver

(19D902845, Sheet 18A, Rev. 1)

FRONT VIEW

IPX-160-VB1
IPX-160-AB1

INTRAPLEX TDM-163 SHELF (20 Chan Config.) [24 Time Slots]

MAIN P/S	RED. P/S	1	2	3	4	5	6	7	8	9	10	11	12	13	14	15	16	17	18	SHELF SLOT
		CM 3A	TM 5		VF 5B	VF 5B	VF 5B	VF 5B	VF 5B	VF 5B	VF 5B	VF 5B	VF 5B	VF 5B		DS 961	DS 961	DS 961	DS 961	INTRAPLEX P/M
					CHL 1/2	CHL 3/4	CHL 5/6	CHL 7/8	CHL 9/10	CHL 11/12	CHL 13/14	CHL 15/16	CHL 17/18	CHL 19/20		CHL 1-5	CHL 6-10	CHL 11-15	CHL 16-20	MODULE FUNCTION
					1/2	3/4	5/6	7/8	9/10	11/12	13/14	15/16	17/18	19/20		21	22	23	24	T1 TIME SLOT(S)

REAR VIEW

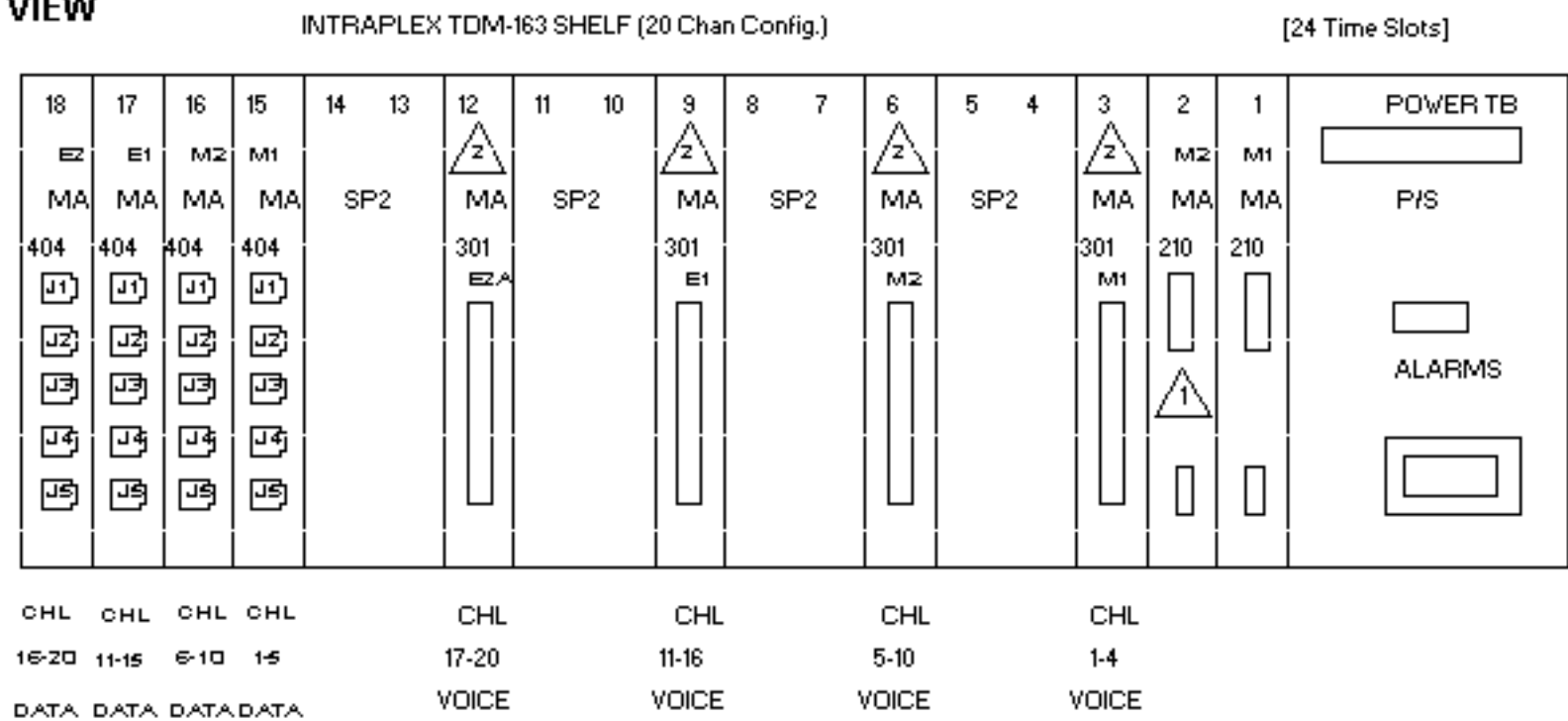

NOTES

- MA-210 & TM5 INSTALLED IN SLOT 2 OF SHELF-VOTER END ONLY.
- ASSIGN SPECIAL SLOT ASSIGNMENTS FOR MA301'S (OFFSET BY 1) TO ALLOW USE OF MUX CROSS CONNECT. SLOT3 IS INTENTIONALLY OPEN.

FRONT VIEW

IPX-160-VX1
IPX-160-AX1

INTRAPLEX TDM-163 EXPANSION SHELF (24 Chan Config.) [5 Time Slots]

MAIN P/S	RED. P/S	1	2	3	4	5	6	7	8	9	10	11	12	13	14	15	16	17	18	SHELF SLOT	
		CM 3A	TM 5	△ ₂	△ ₂	VF 5B	VF 5B										DS 961				INTRAPLEX P/N
			△ ₁			CHL 21/22	CHL 23/24										CHL 21-24				MODULE FUNCTION
						1/2	3/4										5				T1 TIME SLOT(S)

REAR VIEW

INTRAPLEX TDM-163 EXPANSION SHELF (24 Chan Config.) [5 Time Slots]

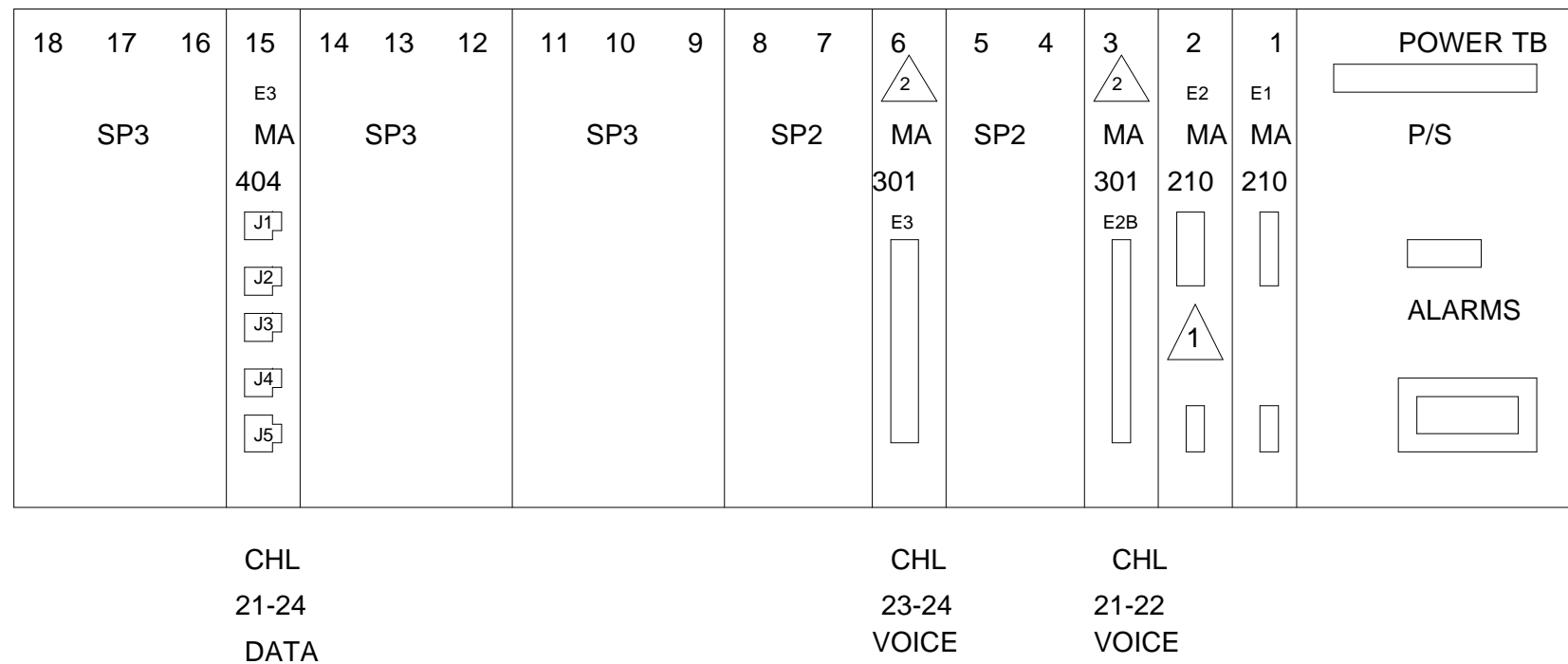

CHL 21-24 DATA

CHL 23-24 VOICE

CHL 21-22 VOICE

NOTES

- △₁ MA-210 & TM5 INSTALLED IN SLOT 2 OF SHELF-VOTER END ONLY.
- △₂ ASSIGN SPECIAL SLOT ASSIGNMENTS FOR MA301'S (OFFSET BY 2) TO ALLOW USE OF MUX CROSS CONNECT. SLOTS 3&4 ARE INTENTIONALLY OPEN.

MUX RJ12 CONFIGURATION

- 1 MUX TXC (MUX to SC REFERENCE)
- 2 MUX TXD (EGE EQ to MUX)
- 3 MUX TERM TIME (EGE EQ CLOCK to MUX)
- 4 MUX RXD (MUX to EGE EQ)
- 5 MUX GROUND
- 6 MUX RXC (MUX to EGE EQ)

Multiple Receiver Simulcast, Ch. 21 - 24

(19C852610, Sh. 6, Rev. 1)

INTRAPLEX MUX X-CONNECT

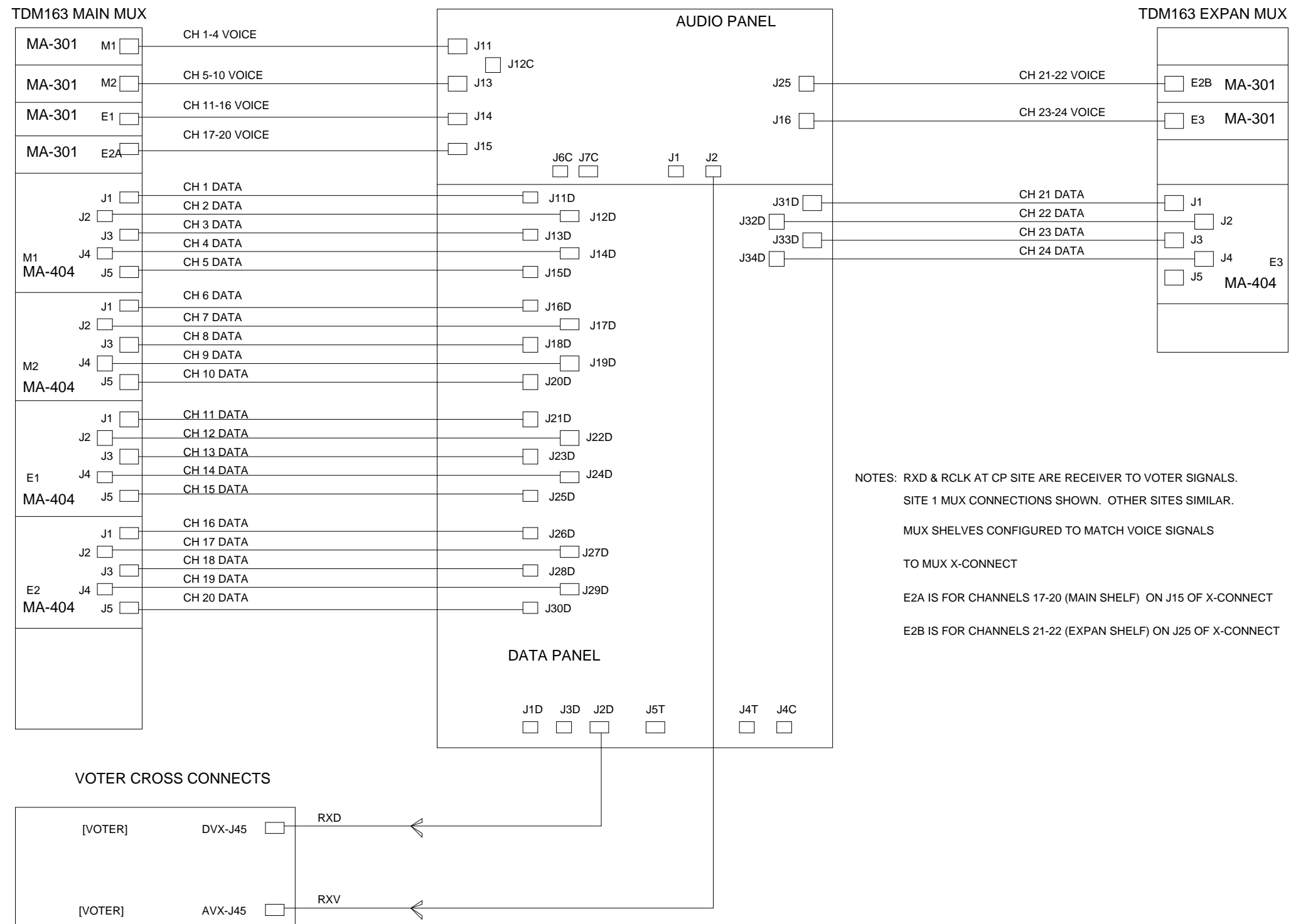

NOTES: RXD & RCLK AT CP SITE ARE RECEIVER TO VOTER SIGNALS.
 SITE 1 MUX CONNECTIONS SHOWN. OTHER SITES SIMILAR.
 MUX SHELVES CONFIGURED TO MATCH VOICE SIGNALS
 TO MUX X-CONNECT
 E2A IS FOR CHANNELS 17-20 (MAIN SHELF) ON J15 OF X-CONNECT
 E2B IS FOR CHANNELS 21-22 (EXPAN SHELF) ON J25 OF X-CONNECT

Multiple Receiver Simulcast,
 Cross-Connect-Voter

(19C852615, Sh. 5, Rev. 1)

INTRAPLEX MUX X-CONNECT

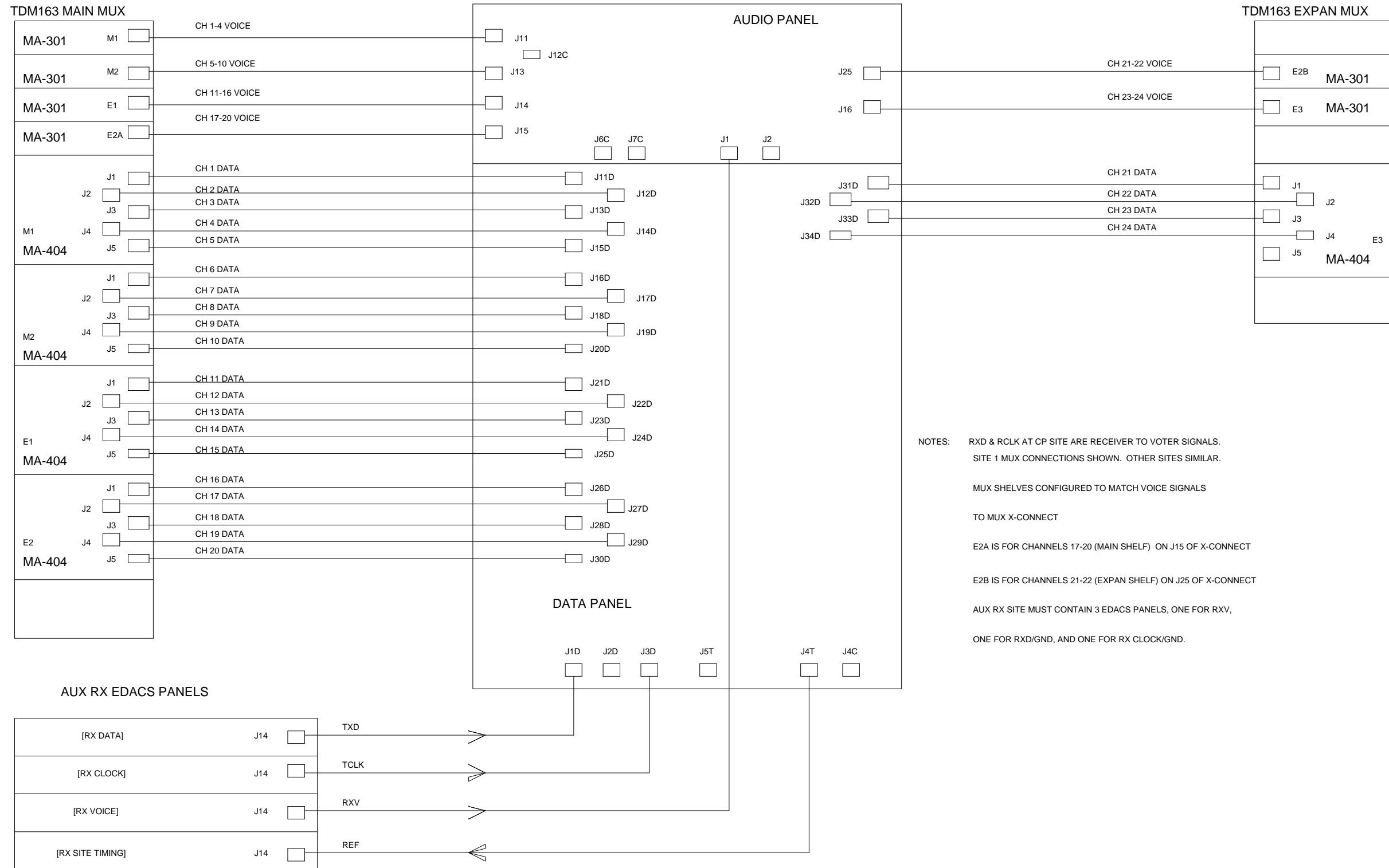

Multiple Receiver Simulcast, Cross-Connect

(19C852615, Sh. 6, Rev. 1)

This page intentionally left blank