

MAINTENANCE MANUAL
851-870 MHz, 110 WATT POWER AMPLIFIER
19D902797G5

PA FAN PLATE ASSEMBLY
188D6127G1

TABLE OF CONTENTS

	<u>Page</u>
DESCRIPTION	Front Page
SPECIFICATIONS	1
CIRCUIT ANALYSIS	1
POWER AMPLIFIER	1
Small Signal Gain Stage	1
Driver Module	1
Final Power Stage	1
Power Sense and Isolation Stages	1
POWER CONTROL	1
Theory of Operation	2
Signal Interface	2
SERVICING	2
BLOCK DIAGRAM	1
TROUBLESHOOTING GUIDE	3
POWER AMPLIFIER READINGS	3
IC DATA	3
ASSEMBLY DIAGRAM	4
PARTS LIST	6
OUTLINE DIAGRAM	7
ASSEMBLY DIAGRAM	7
SCHEMATIC DIAGRAM	8
PARTS LIST	Back Cover
PRODUCTION CHANGES	Back Cover

DESCRIPTION

The 800 MHz MASTR III Power Amplifier Assembly is a wide band RF power amplifier operating over the 851-870 MHz range without tuning. Its main function is to amplify the 10 mW FM signal from the Transmitter Synthesizer to the rated RF output at the antenna port. The output of the Power Amplifier Assembly is adjustable from rated power to 10dB below rated power at the PA output J104.

The assembly consists of a printed wiring board (A1) and associated components, including a power module

and an RF power transistor, mounted to the heat sink assembly. The printed wiring board (A1) contains both the power amplifier circuitry and the power control circuitry. The heatsink assembly includes a copper heat spreader for the power transistor.

Unfiltered supply voltage, A+, for the power amplifier circuits enters the assembly via feedthrough capacitor, C1. Power cable W4 routes the A+ from C1 to J103 on the PWB. Filtered A+ voltage for the power control circuit enters the assembly via control cable W13 which connects to the PWB at J201.

SYMBOL	PART NO.	DESCRIPTION
4	SBS 123 01/10	Spring nut.
5	19A702339P510	Screw, thread forming, flat head.
6	19A701312P5	Washer, plain steel, 3.5 mm.
7	19A702381P510	Screw, thread forming, pan head.
9	19A700136P19	Sleeve
10	105 8567/1	Guard, fan.
11	19A701863P12	Clamp, loop.
13	19A700033P6	Washer, lock, ext tooth.
14	19A700034P5	Nut, hex, steel.
B1 and B2	BKV 301 216/02	DC fan.
W1	344A3337P4	Cable.
WT1 and WT2	7142645P1	Conductor, splice.

PRODUCTION CHANGES

Changes in the equipment to improve or to simplify circuits are identified by a "Revision Letter", which is stamped after the model number of the unit. The revision stamped on the unit includes all previous revisions. Refer to the Parts List for descriptions of parts affected by these revisions.

REV. A - POWER AMPLIFIER BOARD 19D902794G5
 Incorporated into production radios.

REV. A - POWER AMPLIFIER 19D902797G5
REV. B - POWER AMPLIFIER BOARD 19D902794G5
 To correct minor PWB errors and incorporate a new RF output device. New PWB board and Q5 was RYN121655/1. C43 was 1.2 pF (344A3126P203).

REV. C - POWER AMPLIFIER BOARD 19D902794G5
 To incorporate new style of RF output device. New PWB. C43 was 2.2pF(344A3126P2) and C44 was 1.2pF (344A3126P203).

REV. D - POWER AMPLIFIER 19D902794G5
 To incorporate new style of RF driver module U2. U2 was RYT 901 6074/1. R1 thru R4 were 5K ohms (REL 316 214/5). PWB changed.

REV. E - POWER AMPLIFIER BOARD 19D902794G5
 Correct missing ground pattern. DA wire added from C49(-) to nearest ground pattern.

REV. F - POWER AMPLIFIER BOARD 19D902794G5
 To improve impedance mismatch. PWB change to add ground pattern to C49(-).

Ericsson Inc.
 Private Radio Systems
 Mountain View Road
 Lynchburg, Virginia 24502
 1-800-592-7711 (Outside USA, 804-592-7711)



Table 1 - General Specifications

ITEM	SPECIFICATION
FREQUENCY	851-870 MHz
OUTPUT POWER (RF)	11 TO 110 W @ J104
INPUT POWER (RF)	10 mW min. into $\leq 2:1$ VSWR
TEMPERATURE RANGE	-30°C to +60°C (Ambient air)
SUPPLY VOLTAGE	26.0V
CURRENT	14A max. (11 A typical @ 110W, 26.0 V)
DUTY CYCLE	Continuous
STABILITY	Stable into 3:1 VSWR; all temp., voltage, FREQ. 11-110W
RUGGEDNESS AT HIGH VSWR	No damage into open or shorted load

The Power Control circuitry sets the output power level by adjusting the PA Power Set level. It keeps the output power constant despite variations in input power, power amplifier gain, or temperature through the use of a feedback control loop in the PA assembly.

CIRCUIT ANALYSIS

POWER AMPLIFIER

The power amplifier section of the PA Board consists of a Small Signal Gain Stage, a Driver Module, a Final Power Stage, and Power Sense and Isolation Stages. All these gain stages have an input and output impedance of 50 ohms. Figure 1 is a block diagram showing the signal flow within the Power Amplifier Assembly.

Small Signal Gain Stage (U101)

This stage uses a broadband silicon monolithic microwave integrated circuit (MMIC) amplifier. The signal from transmitter synthesizer, typically 10 dBm (10 mW), is input through a 10 dB resistive pad (R101, R102, and R103). The stage amplifies the resulting 0 dBm (1 mW) signal to the necessary level to achieve desired PA output power (typical +5 dBm for 110W out).

Bias for the MMIC is supplied by an 8V regulator (U4). This voltage is DC coupled to pin 6 and is supplied through a dropping resistor, R43, for pin 2. Power control for the Power Amplifier Assembly is performed by controlling the RF level out of the MMIC by varying the control voltage at pin 5.

Driver Module (U2)

The Driver Module is a 35 dB gain, 4-stage, linear hybrid amplifier. The first two stages of the module are identical FET amplifiers, class A biased to provide maximum gain. Stages 3 and 4 are bipolar transistors, class AB biased to provide maximum saturated power and efficiency. The quiescent current of these stages is set by variable resistors R1, R2, R4, and R3 respectively. Typical bias current for each stage is 100, 90, 90 & 90mA respectively.

CAUTION

These currents are factory set. Field adjustment is not recommended, and may result in device failure.

The voltage for the bias circuitry is supplied by U7, a voltage regulator. A transistor switch, Q3, is used to apply this voltage when the unit is keyed. The nominal output power of this stage is 42.4 dBm (17.5W).

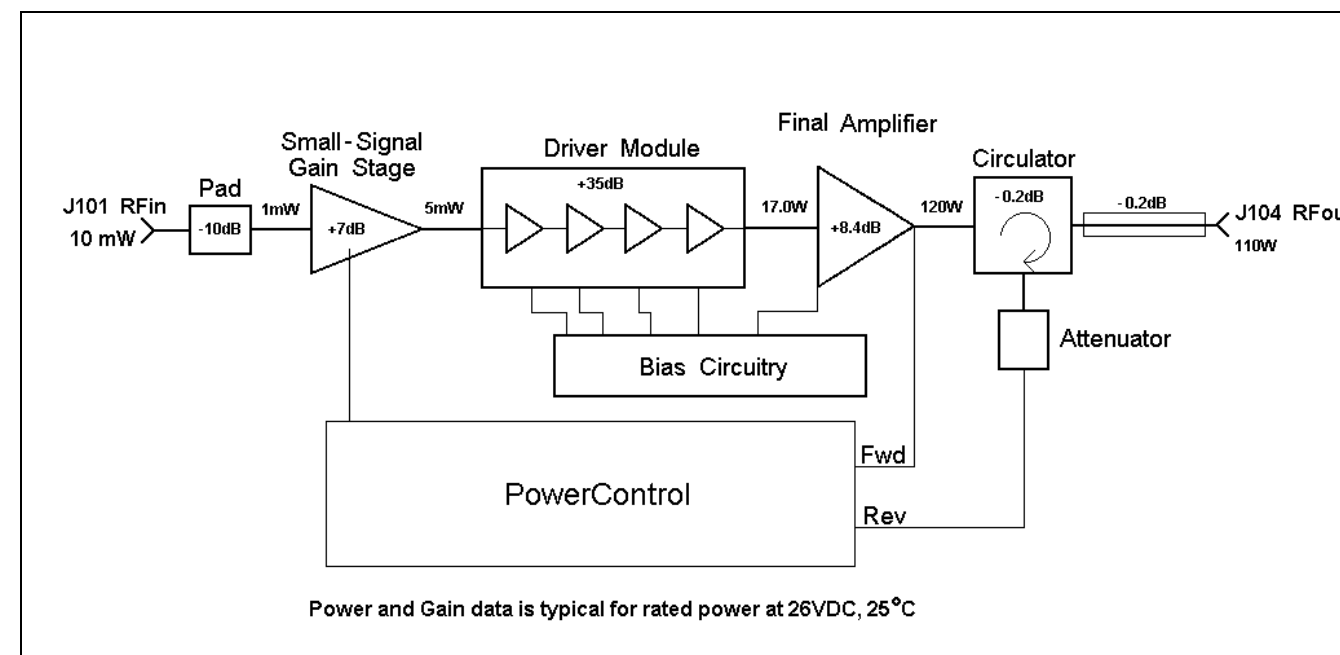

Figure 1 - Block Diagram

Final Power Stage (Q5)

The Final Power Stage of the unit consists of a push-pull pair of silicon bipolar power transistors mounted on a single flange, Q5, and its associated matching and bias circuitry. A quarter-wave transmission line transformer feeds a pair of 25 ohm lines in parallel, one of which is 180° longer than the other, to create a microstrip balun. The resulting balanced circuit is transformed by reactive components to match the input impedance of the final device. Similar circuitry is used on the output to match the device's output impedance. The quiescent current of transistor Q5 is set by variable resistor R48 for Class AB operation. Typical bias current is 400 mA for this stage.

CAUTION

These currents are factory set. Field adjustment is not recommended, and may result in device failure.

The result is a typical 8.4 dB gain stage capable of producing a nominal 50.8 dBm (120W) of RF power.

Power Sense and Isolation Stages

Integrated into the output microstrip balun, an eighth-wave directional coupler is used to sense the magnitude of forward power. D6, an active detector, is used to convert this level to a DC voltage proportional to forward power, and this voltage is sent to the power control circuitry.

The amplified signal from the Final Power Stage is fed to U6, a circulator, to provide 20 dB typical isolation from load mismatches. The device insertion loss of 0.2 dB maximum, along with the microstrip trace losses, provide 50.4 dBm (110W) of RF power at the PA output, J104.

The third port of the circulator is terminated by a 20 dB power attenuator, AT1, followed by a resistive pad, R35, R36, R39. Any signal reflected back into the Power Amplifier Assembly is directed by the circulator through the pads, and is converted to a DC voltage by D7. This voltage is sent to the power control circuitry.

POWER CONTROL

The Power Control circuitry performs four basic functions. It keys and unkeys the PA, sets the PA output power, protects the PA against adverse conditions, and provides a voltage proportional to output power at the interface cable.

Keying And Unkeying The PA

To key the PA, the digital controller places 5 volts on the PA key line, J201-2. Zero volts on the PA key line causes the PA to unkey. If the control cable (W13) is disconnected, with nothing actively driving the PA key line, the PA will remain unkeyed.

PA Output Power Set

PA output power is set according to the level of the Power Set line. Four (4) volts on this line will produce minimum power. As the voltage increases toward eight (8) volts, the power will increase to the maximum rated output. The PA output power is initially set for an output of 110 watts at J104. This is done by adjusting R204 while injecting a 10 mW signal at J1 and applying 8 volts to J201-3. After setting the maximum power level, changing the output power is done by varying the voltage applied on the Power Set line.

PA Protection

The power control also protects the PA against over temperature and high VSWR conditions.

An over temperature condition exists when the flange temperature of the final output transistor reaches 80°C. At this point the output power will drop below its set level. The output power will continue to drop such that when the flange temperature reaches 125°C the PA output drops at least 10 dB below its set level.

Reflected power is limited to 25% of the set power. If the output VSWR degrades to worse than 3:1 the forward power will be reduced to limit the reflected power to 25% of the set power. The Power Sensor line indicates when the PA is operating in a cutback condition. If the PA is keyed and the power control is cutting back, the Power Sensor line will drop to zero (0) volts and the PA alarm light on the station will turn on.

Power Monitor

A DC voltage proportional to forward power, provided by the detection circuit of the Power Sense stage, is buffered and delivered to the PWR Monitor line of the interface connector.

Theory Of Operation

Power control of the MASTR III Power Amplifier is accomplished with a feedback control loop. The three possible feedback signals are: representation of forward power, temperature sensitive scaled representation of forward power, or representation of reflected power. The three signals are input to a diode summing junction which selects the largest of the three for use as the feedback.

The microstrip directional coupler samples the output power and produces a voltage, V_f , proportional to the forward output power. The power control compares the forward voltage, V_f , to a reference voltage at U3. The output of U3 adjusts the control voltage at pin 5 of the MMIC of the Small Signal Gain Stage. This varies the gain through the stage, and

controls the power output level of the Power Amplifier Assembly.

During over temperature operation, a scaled representation of the forward power is maintained constant by varying the control voltage line. Thermal resistor RT1 sensing an increase in temperature causes the output of U1.1 to increase. If the output of U1.1 becomes larger than the other feedback lines, the output of U3.2 will begin to decrease. This causes the gain of U101 to decrease. Since the scaling is a function of temperature the power is reduced as the temperature increases.

Under VSWR cutback operation the reverse voltage, V_r , representative of the reflected output power is held below a threshold by reducing the control voltage as necessary. If V_r increases at U1.2 beyond the preset threshold an increase at U3.2 will result. This causes a subsequent reduction in the control voltage to U1. Thus the power control circuit reduces the output power in order to limit the reflected power to 25% of the set power.

Signal Interface

The signal interface to the MASTR III Power Amplifier is supported by a six position feedthrough connector, J201, with the following pinout:

- 1 - PWR Sensor
- 2 - PA Key
- 3 - PA PWR Set
- 4 - PWR Monitor
- 5 - Ground
- 6 - Fil A+

Pwr Sensor

This line indicates when the PA is experiencing adverse conditions. Under normal operation, while the PA is keyed, this line will be proportional to forward power. Minimum power (zero watts) corresponds to 2.5 volts while maximum power corresponds to 4.5 volts. This voltage is not temperature compensated and no effort is made to calibrate this signal to an absolute power level. It is intended to provide a relative indication of forward power and to discriminate between normal and cutback operation.

Zero volts on this line, when the PA is keyed, indicates the forward power is cutback. This power cutback may be due to high reflected power or may be due to high PA tempera-

tures. This fault condition may indicate a problem with the PA or may indicate a system problem external to the Power Amplifier. High VSWR may be due to a poor antenna and high temperature may be due to a blocked cabinet vent. Zero volts on this line, when the PA is keyed, does not indicate zero forward power. Zero volts indicates the PA is protecting itself due to adverse conditions. If the adverse condition, either high VSWR or high temperature is eliminated, the power will return to normal and the PWR SENSOR voltage will rise above 2.5 volts.

PA Key (Interface Connector Pin 2)

This line is used to key and unkey the PA, UNKEY=0 volt and KEY=5 volts. The driver of this line must be capable of supplying 5 volts at 1.0 mA. The appropriate key sequence requires RF from the transmit synthesizer be input to the PA before the KEY line is energized.

PA PWR Set (Interface Connector Pin 3)

This line is used to set the RF Power Output of the PA. Minimum power output equals 4 volts and maximum power output equals 8 volts. The driver of this line must be capable of supplying 8 volts at 1.0 mA.

Fil A+ (Interfaces Connector Pin 6)

This line provides the filtered supply voltage for the Power Control. The driver of this line must be capable of supplying 13.4 volts $\pm 20\%$ at 100 mA.

PWR Monitor

This line provides a DC voltage proportional to forward power.

SERVICING

When transistor Q5 (RYN 121 6013/1) is replaced or used which has a date code 9601 thru 9621, capacitor C110 must be removed. The date code is the last four digits of the number printed in the lower right corner on the top of Q5. If Q5 has a date code other than 9601 thru 9624, capacitor C110 must be installed.

TROUBLESHOOTING GUIDE

SYMPTOM	AREAS TO CHECK	INDICATIONS
1. No power or low power at Antenna Port.	<ol style="list-style-type: none"> 1. Measure the transmitter output power before the duplexer or antenna switch (for simplex mode). 2. Measure the transmitter output power before the low pass filter. 	<p>The presence of power at this port is an indication of a defective duplexer, switch, or cables.</p> <p>The presence of power at this port is an indication of a defective filter or cables.</p>
2. No power at PA output port and PA ALARM is OFF.	<ol style="list-style-type: none"> 1. Station is in receive mode. 	
3. No power at PA output port and PA ALARM is ON.	<ol style="list-style-type: none"> 1. No RF input to the PA. Check connection between PA and TX Synthesizer. 2. Check the logic or DC inputs to the PA from the Interface Board through J201. <ol style="list-style-type: none"> a. J201-PA KEY b. J201-3 POWER SET c. J201-6 13.8 VF 3. Check the bias voltage on the base of Q5. 4. Check the bias voltage at module U2. <ul style="list-style-type: none"> pin 2 pin 4 pin 6 pin 8 <p>Note: There is no pin 3 on module U2. Pin 4 is the 3rd pin physically.</p> 	<p>TX Synthesizer should deliver a minimum of 10 mW (10dBm) to the PA.</p> <p>5 volts during transmit</p> <p>4 volts to 8 volts (4 volts represents zero RF power)</p> <p>13.8 Vdc ±20%</p> <p>Voltage should be .73V nominal.</p> <p>Voltages should be: 14-18V nominal 14-18V nominal 0.7V nominal 0.7V nominal</p>
4. Low power at PA output port and PA ALARM is OFF.	<ol style="list-style-type: none"> 1. Low RF input to PA from TX Synthesizer. 2. Check the voltage on J201-3 (POWER SET). 3. Check the power supply voltage on the collector of Q5. 4. Check the bias voltage on the base of Q5. 5. Check the bias voltage at module U2. <ul style="list-style-type: none"> pin 2 pin 4 pin 6 pin 8 <p>Note: There is no pin 3 on module U2. Pin 4 is the 3rd pin physically.</p> 	<p>Power should be a minimum of 10 mW (10 dBm).</p> <p>For nominal output power, this voltage should be above 7 volts.</p> <p>Voltage should be nominal 26.0 Vdc.</p> <p>Voltage should be .73V nominal.</p> <p>Voltages should be: 14-18V nominal 14-18V nominal 0.7V nominal 0.7V nominal</p>
5. Low power at PA output port and PA ALARM is ON.	<ol style="list-style-type: none"> 1. Check for over temperature and/or a high VSWR condition due to a mismatch at the output port. 	<p>The power control circuit protects the PA by cutting back the power. In case of a mismatch, refer to symptom 1.</p>

800 MHz POWER AMPLIFIER VOLTAGE CHART

PARAMETER (50 ohm, -30°C to +60°C)	REFERENCE SYMBOL	READINGS (volts DC)
SUPPLY VOLTAGE	A+	26.0 +5, - 20%
CONTROL VOLTAGE	Vctl	0-2V
FORWARD VOLTAGE	Vf	4-5V
REVERSE VOLTAGE	Vr	2-4V
POWER SENSE	J201-1	2.5 - 4V
PA KEY	J202-2	5V
POWER SET	J202-3	4 - 8V
13.8 VF	J201-6	13.8V ±20%

RATED POWER FOR MASTR III 800 MHz BASE STATION

FREQUENCY MHz	STANDARD	ADJUSTABLE RANGE
851-870	100W, AFTER LOW PASS FILTER	10-100W, AFTER LOW PASS FILTER

IC DATA

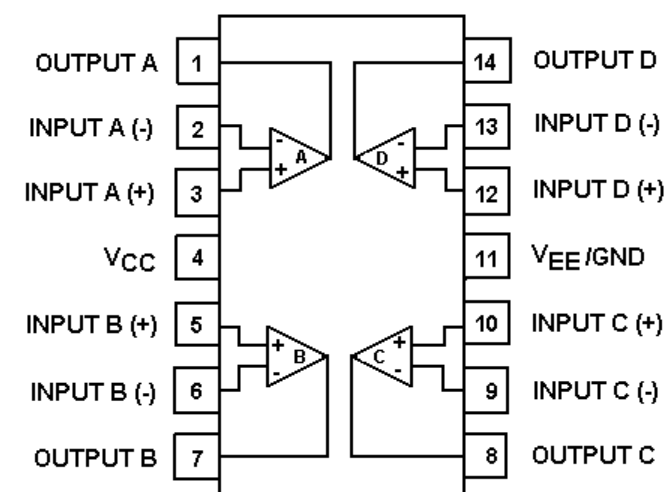

**U3, U1
19A701789P4
Quad Op-Amp**

Terminal	Function
1	Ground and thermal contact
2	Vcc1
3	Ground
4	RF
5	Power control
6	RF _{OUT} and Vcc2
7	Ground and thermal contact
8	Ground and thermal contact

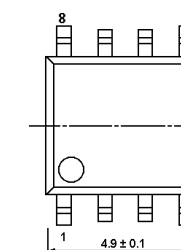

**U101
RYT1016155/1**

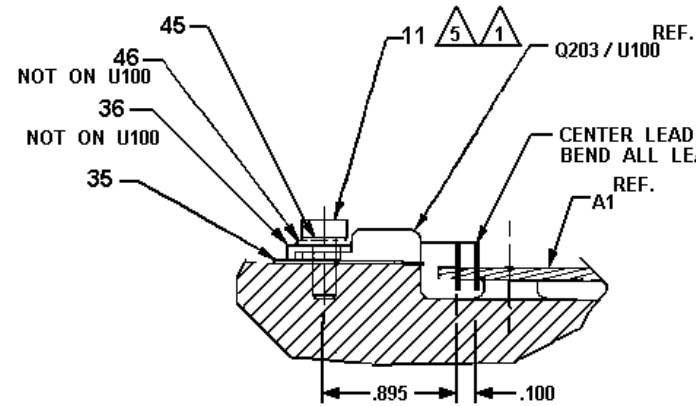

SECTION C - C
 (TAKEN FROM SHEET 1)
 LEAD FORMING AND HARDWARE
 STACKUP FOR Q203 & U100
 FOR Q203, U100 USE
 EGE TOOL #423445G1A

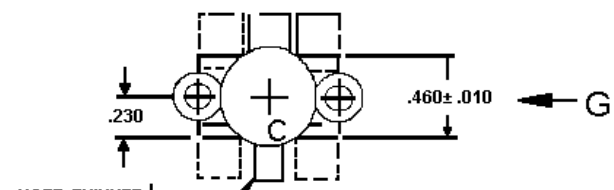

DETAIL F
 LEAD TRIMMING
 FOR Q1 THRU Q3 G3 USE EGE TOOL #423445 G1C
 FOR Q101 THRU Q103, G1 USE EGE TOOL #902/97 -G1A
 (TAKEN FROM SHEET 1)

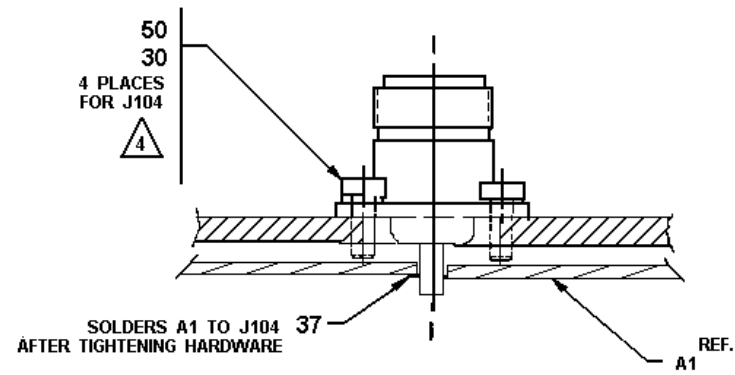

SECTION D - D
 (TAKEN FROM SHEET 1)

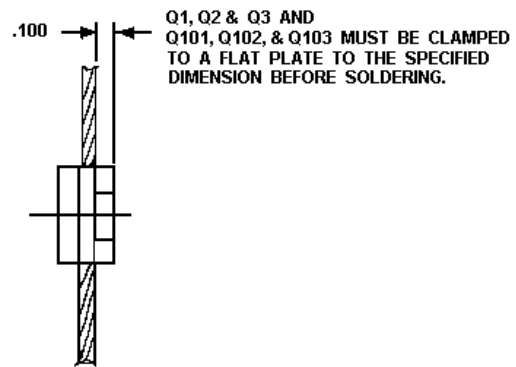

VIEW G
 TYPICAL LEAD FORMING
 & ASSEMBLY POSITIONING
 FOR Q1 THRU Q3
 FOR Q101 THRU Q103

**POWER AMPLIFIER ASSEMBLY
 19D902797G5**

(19D902797, Sh. 2, Rev. 10)

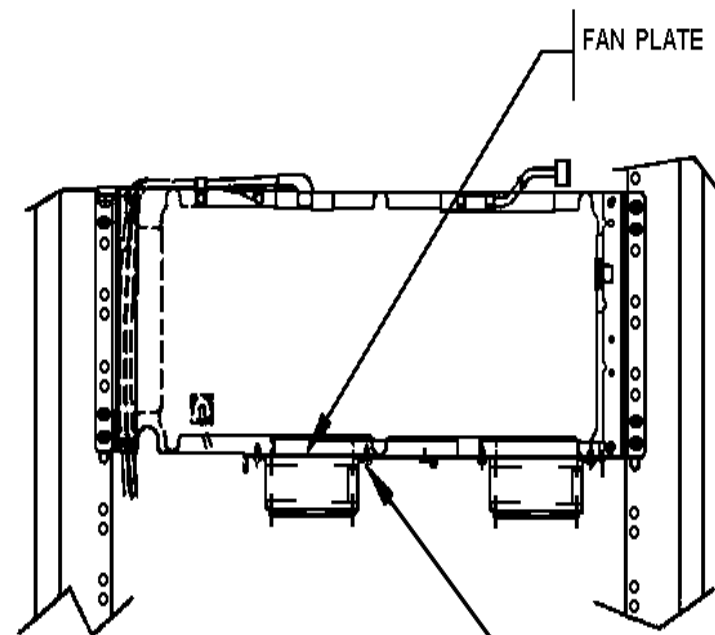
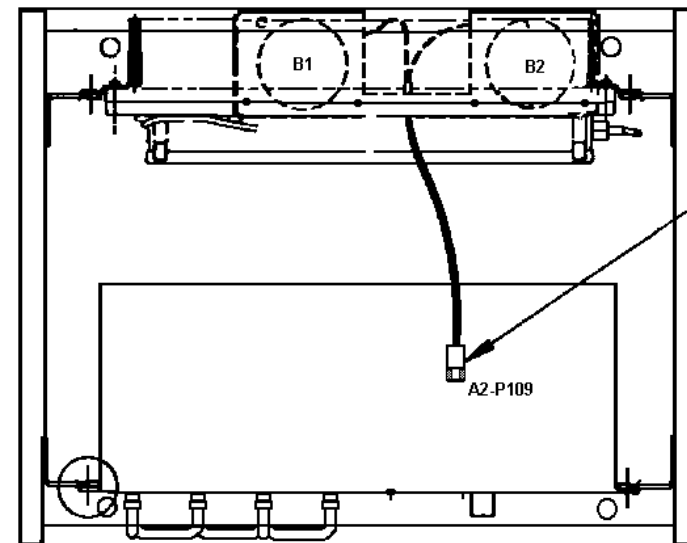

FRONT VIEW

**PA FAN PLATE ASSEMBLY
 188D6127G1**

(188D6131, Rev. 1)

POWER AMPLIFIER
19D902797G5

SYMBOL	PART NO.	DESCRIPTION
A1		Power Amplifier Board 19D902794G5
----- ATTENUATORS -----		
AT1	REPYA01501/1	Attenuation: 20dB + or - 1 dB 50 ohms.
----- CAPACITORS -----		
C1	19A116708P2	Feedthru: 0.01 uF + or - 100 -0%, 500 VDCW; sim to Eric 327-050 - XW0103P.
C1 thru C9	19A702052P26	Ceramic: 0.1uF + or - 10%, 50 VDCW.
C10	344A3126P38	Porcelain: 100pF + or - 5%, 500 VDCW; sim to 101JT500X.
C11	19A702052P26	Ceramic: 0.1uF + or - 10%, 50 VDCW.
C12 and C13	344A3126P62	Porcelain: 1000pF + or - 5%, 50 VDCW; sim to 102JT500X.
C14 and C15	19A702052P26	Ceramic: 0.1uF + or - 10%, 50 VDCW.
C16 and C17	344A3126P38	Porcelain: 100pF + or - 5%, 500 VDCW; sim to 101JT500X.
C18 thru C22	RJE5843358/15E	Tantalum: 15uF + or - 10%, 35 VDCW.
C23	19A702052P26	Ceramic: 0.1uF + or - 10%, 50 VDCW.
C24 and C25	19A702052P5	Ceramic: 1000pF + or - 10%, 50 VDCW.
C26	19A705108P25	Mica Chip: 33pF + or - 5%, 500 VDCW, temp coef 0 + 50 PPM/C.
C27 thru C32	19A702052P5	Ceramic: 1000pF + or - 10%, 50 VDCW.
C33 thru C39	19A705108P25	Mica Chip: 33pF + or - 5%, 500 VDCW, temp coef 0 + 50 PPM/C.
C40	19A702052P26	Ceramic: 0.1uF + or - 10%, 50 VDCW.
C41	19A705108P25	Mica Chip: 33pF + or - 5%, 500 VDCW, temp coef 0 + 50 PPM/C.
C42	19A702052P26	Ceramic: 0.1uF + or - 10%, 50 VDCW.
C43	344A3126P203	Porcelain: 1.2pF + or - 0.25pF, 500 VDCW; sim to 1R2CT500X.
C44	344A3126P205	Porcelain: 1.8pF + or - 0.25pF, 500 VDCW; sim to 1R8CT500X.
C46 thru C53	344A3126P38	Porcelain: 100pF + or - 5%, 500 VDCW; sim to 101JT500X.
C59 and C60	RJE5843358/15E	Tantalum: 15uF + or - 10%, 35 VDCW.
C61	19A705205P18	Tantalum: 4.7uF + or - 20%, 35 VDCW.
C63 thru C68	RJE5843358/15E	Tantalum: 15uF + or - 10%, 35 VDCW.
C70	RJE5843358/15E	Tantalum: 15uF + or - 10%, 35 VDCW.
C79 thru C81	19A705108P25	Mica Chip: 33pF + or - 5%, 500 VDCW, temp coef 0 + 50 PPM/C.
C82 thru C85	344A3126P38	Porcelain: 100pF + or - 5%, 500 VDCW; sim to 101JT500X.
C93	RJE5843358/15E	Tantalum: 15uF + or - 10%, 35 VDCW.
C101 and C102	19A702236P36	Ceramic: 27 pF + or - 5%, 50 VDCW, temp coef 0 + or -30 PPM/C.
C103	19A702052P26	Ceramic: 0.1uF + or - 10%, 50 VDCW.
C104	19A702236P10	Ceramic: 2.2 pF + or -2.5 pF, 50 VDCW, temp or -30 PPM/C.
C105	19A702236P36	Ceramic: 27 pF + or - 5%, 50 VDCW, temp coef 0 + or -30 PPM/C.

SYMBOL	PART NO.	DESCRIPTION
C106 thru C108	344A3126P38	Porcelain: 100pF + or - 5%, 500 VDCW; sim to 101JT500X.
C109	344A3126P1	Porcelain: 3.3pF + or - 0.25pF, 500 VDCW; sim to 3R3CT500X.
C110	344A3126P203	Porcelain: 3.3pF + or - 0.25pF, 500 VDCW; sim to 3R3CT500.
C111 and C112	344A3126P38	Porcelain: 100pF + or - 5%, 500 VDCW; sim to 101JT500X.
C113	19A705108P25	Mica Chip: 33pF + or - 5%, 500 VDCW, temp coef 0 + 50 PPM/C.
C201	19A702061P37	Ceramic: 33pF + or - 5%, 50 VDCW, temp coef 0 + or -30 PPM/C.
C202	19A702052P26	Ceramic: 0.1uF + or - 10%, 50 VDCW.
C203	19A702061P37	Ceramic: 33pF + or - 5%, 50 VDCW, temp coef 0 + or -30 PPM/C.
C205 thru C207	19A702052P26	Ceramic: 0.1uF + or - 10%, 50 VDCW.
C208 thru C211	19A702061P37	Ceramic: 33pF + or - 5%, 50 VDCW, temp coef 0 + or -30 PPM/C.
C213	344A3126P38	Porcelain: 100pF + or - 5%, 500 VDCW; sim to 101JT500X.
C214	19A702052P26	Ceramic: 0.1uF + or - 10%, 50 VDCW.
C215	RJE5843358/15E	Tantalum: 15 uF + or - 10%, 35 VDCW
C216	344A3126P38	Porcelain: 100pF + or - 5%, 500 VDCW; sim to 101JT500X.
C217	19A702052P26	Ceramic: 0.1uF + or - 10%, 50 VDCW.
C224	19A702052P26	Ceramic: 0.1uF + or - 10%, 50 VDCW.
C225	344A3126P38	Porcelain: 100pF + or - 5%, 500 VDCW; sim to 101JT500X.
C226	RJE5843358/15E	Tantalum: 15 uF + or - 10%, 35 VDCW
C227	19A702052P26	Ceramic: 0.1uF + or - 10%, 50 VDCW.
----- DIODES -----		
D1 thru D5	19A700053P3	Silicon: 2 Diodes in Series, Common Cathode; sim to MBAV701.
D6 thru D8	19A705377P4	Silicon, Hot Carrier: sim to HSMS-28D2.
D9	RKZ12303/1	Diode, silicon.
----- FILTERS -----		
FL1 thru FL7	REG704202	Ferrite, bead.
FL10	RTNUA50101/1	Low Pass: (Used in 850-930 MHZ).
----- JACKS -----		
J101	19A705512P1	Connector, RF SMB Series: sim to AMP No. 221111-1.
J101	RNT403185/02	Connection, RF; SMD 50 ohms.
J103	19A134263P1	Contact, electrical: sim to Selectro 229-1082-00-0-590.
J104	7777145P5	Receptacle: sim to Amphenol 82-97.
J201	19A704852P32	Printed wire, two part: 6 contacts, sim to Molex 22-29-2061.
----- INDUCTORS -----		
L1 thru L3	19A705470P13	Coil: 0.10uH + or - 20%.
L101	344A3678P8R2	Coil, Fixed: RF SM.
L102	19A705470P9	Coil, Fixed: 47nH; sim to Toko 380NB-47nM.
L201	19A705470P13	Coil: 0.10uH + or - 20%.
L202		
----- TRANSISTORS -----		
Q1 and Q2	19A700076P2	Silicon, NPN: sim to MMBT3904, low profile.

SYMBOL	PART NO.	DESCRIPTION
Q3	19A134577P2	Silicon, PNP: sim to Phillips BCX51-16
Q4	RYN121634/1	Silicon, Power; SMD.
Q5	RYN1216013/1	Power: 150W
Q6 and Q7	RYN121634/1	Silicon, SMD.
----- RESISTORS -----		
R1 thru R4	REL316215/2	Potentiometer: 20K 10T SMD.
R5 thru R7	19B800607P103	Metal film: 10K ohms + or - 5%, 1/8 w.
R8	19B800607P681	Metal film: 680 ohms + or - 5%, 1/8 w.
R9	19B800607P472	Metal film: 4.7K ohms + or - 5%, 1/8 w.
R10	19B800607P270	Metal film: 27 ohms + or - 5%, 1/8 w.
R11 and R12	19B800607P103	Metal film: 10K ohms + or - 5%, 1/8 w.
R13	19B800607P270	Metal film: 27 ohms + or - 5%, 1/8 w.
R14	19B800607P330	Metal film: 33 ohms + or - 5%, 1/8 w.
R15	19B800607P103	Metal film: 10K ohms + or - 5%, 1/8 w.
R16	19B801486P101	Metal film: 100 ohms + or - 5%, 1/2 w.
R17	19B800607P103	Metal film: 10K ohms + or - 5%, 1/8 w.
R18	19B800607P822	Metal film: 8.2K ohms + or - 5%, 1/8 w.
R19 thru R21	19B800607P103	Metal film: 10K ohms + or - 5%, 1/8 w.
R22	19B800607P472	Metal film: 4.7K ohms + or - 5%, 1/8 w.
R23 thru R25	19B800607P103	Metal film: 10K ohms + or - 5%, 1/8 w.
R26	19B800607P220	Metal film: 22 ohms + or - 5%, 1/8 w.
R27	19B800607P222	Metal film: 2.2K ohms + or - 5%, 1/8 w.
R28	19B800607P220	Metal film: 22 ohms + or - 5%, 1/8 w.
R29	19B801486P101	Metal film: 100 ohms + or - 5%, 1/2 w.
R30	19B800607P510	Metal film: 51 ohms + or - 5%, 1/8 w.
R31	19B800607P332	Metal film: 3.3K ohms + or - 5%, 1/8 w.
R32	19B800607P510	Metal film: 51 ohms + or - 5%, 1/8 w.
R33	19B800607P103	Metal film: 10K ohms + or - 5%, 1/8 w.
R34	19B800607P332	Metal film: 3.3K ohms + or - 5%, 1/8 w.
R35	19B801486P750	Metal film: 75 ohms + or - 5%, 1/2 w.
R36	19B800607P750	Metal film: 75 ohms + or - 5%, 1/8 w.
R37 and R38	19B801486P330	Metal film: 33 ohms + or - 5%, 1/2 w.
R39	19B800607P101	Metal film: 100 ohms + or - 5%, 1/8 w.
R40	19B801486P330	Metal film: 33 ohms + or - 5%, 1/2 w.
R41	19B801486P270	Metal film: 27 ohms + or - 5%, 1/2 w.
R42	19B800607P472	Metal film: 4.7K ohms + or - 5%, 1/8 w.
R43	19B801486P330	Metal film: 33 ohms + or - 5%, 1/2 w.
R44	19B800607P102	Metal film: 1K ohms + or - 5%, 1/8 w.
R45	19A702931P285	Metal film: 7.5K ohms + or -1%, 200 VDCW, 1/8 w.
R46	19A702931P333	Metal film: 21.5K ohms + or - 1%, 200 VDCW, 1/8 w.
R47	19B800607P151	Metal film: 150 ohms + or - 5%, 1/8 w.
R48	REL316214/5	Potentiometer: 5K, 10T SMD.
R49	19B800607P103	Metal film: 10K ohms + or - 5%, 1/8 w.
R50 and R51	19B800607P101	Metal film: 100 ohms + or - 5%, 1/8 w.
R52	19A702931P258	Metal film: 3920 ohms + or - 1%, 200 VDCW, 1/8 w.

SYMBOL	PART NO.	DESCRIPTION
R53	19A702931P137	Metal film: 237 ohms + or - 5%, 1/8w.
R101	19B800607P330	Metal film: 33 ohms + or - 5%, 1/8w.
R102	19B800607P270	Metal film: 27 ohms + or - 5%, 1/8w.
R103	19B800607P330	Metal film: 33 ohms + or - 5%, 1/8w.
R201	19B800607P102	Metal film: 1K ohms + or - 5%, 1/8w.
R202	19B800607P103	Metal film: 10K ohms + or - 5%, 1/8w.
R203	19B800607P473	Metal film: 47K ohms + or - 5%, 1/8w.
R204	REL316215/5	Potentiometer: 5K, 10T SMD.
----- THERMISTOR -----		
RT1	19A705813P2	Thermistor: sim to AL03006-58.2K-97-0100.
----- INTEGRATED CIRCUITS -----		
U1	19A701789P4	Linear: Quad Op Amp: sim to LM224D.
U2	RYT9016120/1	Power : RF.
U3	19A701789P4	Linear: Quad Op Amp: sim to LM224D.
U4 and U5	19A704971P10	Voltage Regulator, 8V: sim to MC8M08CDT.
U6	UNK10243/01	Circulator: 150W.
U7	RYT1136080/1	Volt Regulator.
U101	RYT1016155/1	MMIC.
----- VOLTAGE REGULATORS -----		
VR1	19A700063P102	Silicon: 5.1 Volt Zener; sim to BZX84-C5V1.
----- CABLES -----		
W1	19B803978P1	Cable RF.
W4	19B801695G11	Cable.
----- MISCELLANEOUS -----		
5	19A702381P510	Screw,thread forming: TORX DRIVE No. M3.5-0.6 x 10.
6	7139898P3	Nut, hex, brass: No. 1/4-28.
7	19D902420P7	Heatsink.
9	19A702339P510	Screw.
11	19A702364P510	Machine screw.
14	19B209268P113	Terminal, solderless: sim to AMP 2-34835.4.
	19A115959P2	Wire stranded.
	19B209268P116	Solderless terminal.
16	19A700136P7	Insulated sleeving.
21	19A701863P27	Clip, loop.
22	19A701312P5	Flatwasher: M3.5.
28	19A702364P316	Machine Screw:Pan Head, Steel. (Used in G5, G10).
29	19A700034P4	Nut, hex:No. M3x0.5MM. (Used in G5, G10).
30	19A700032P5	Lockwasher,internal tooth:No. 3MM. (Used in G5 and G10).
37	19A134455P3	Washer, flat.
38	19B801659G4	Cover.
41	19A700033P6	Lockwasher, external tooth, M3.5.
45	N405P5B6	Lockwasher.
46	19A701312P4	Flatwasher: 3.2 ID.
50	19A702381P408	Tap screw, TORX Drive, M3-0.5x8.
63	19B803982P1	Plate.
65	19D902420P7	Heatsink.
70	19B804034P1	Plate, spacer.
75	N404P25	Lockwasher.
W10	19B801937P1	Power cable.
W13	19B801739P1	Cable, Control.

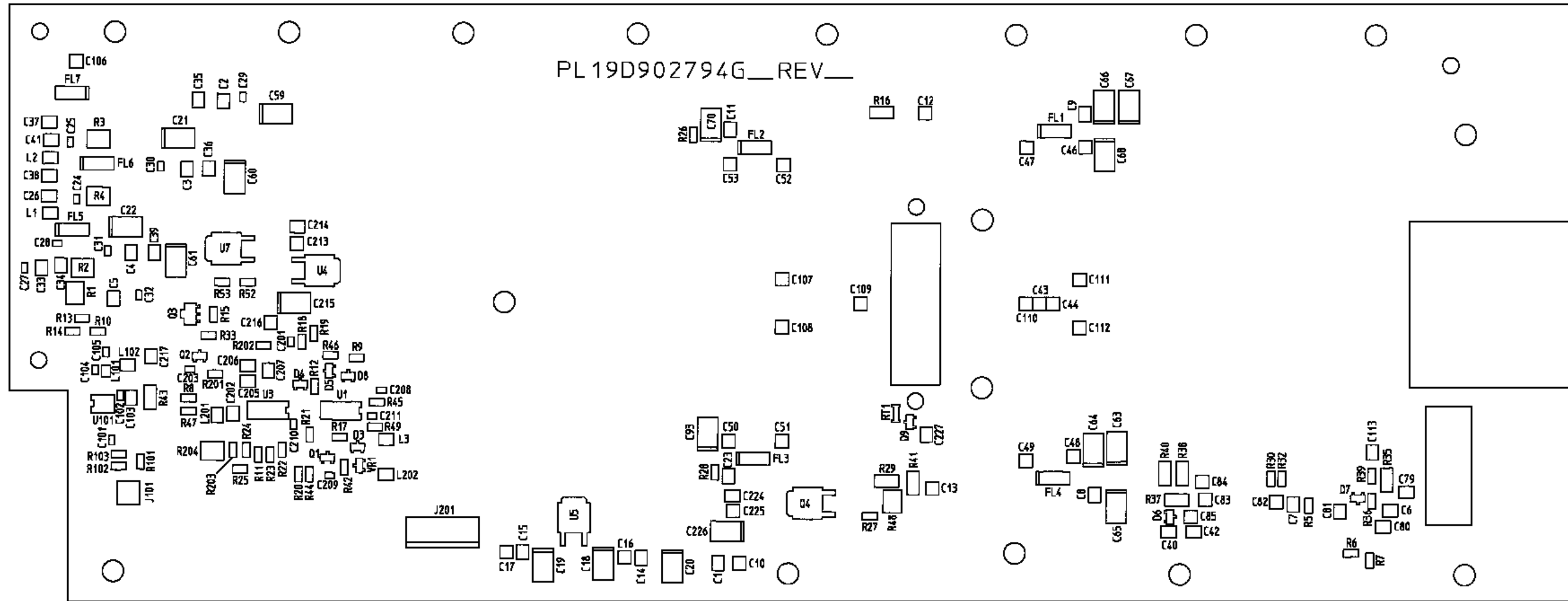

LEAD IDENTIFICATION FOR
U4, U5, U7

(TOP VIEW)



LEAD IDENTIFICATION FOR
Q4, Q6, Q7
(SOT) TRANSISTORS
(TOP VIEW)



LEAD IDENTIFICATION FOR
Q1, Q2
(SOT) TRANSISTORS
(TOP VIEW)



LEAD IDENTIFICATION FOR
D1 - D9, VR1
(SOT) DIODES
(TOP VIEW)



LEAD IDENTIFICATION FOR
Q3
(SOT) TRANSISTORS
(TOP VIEW)



POWER AMPLIFIER BOARD A1
19D902794G5

(19D902794 Sh. 3, Rev. 12)

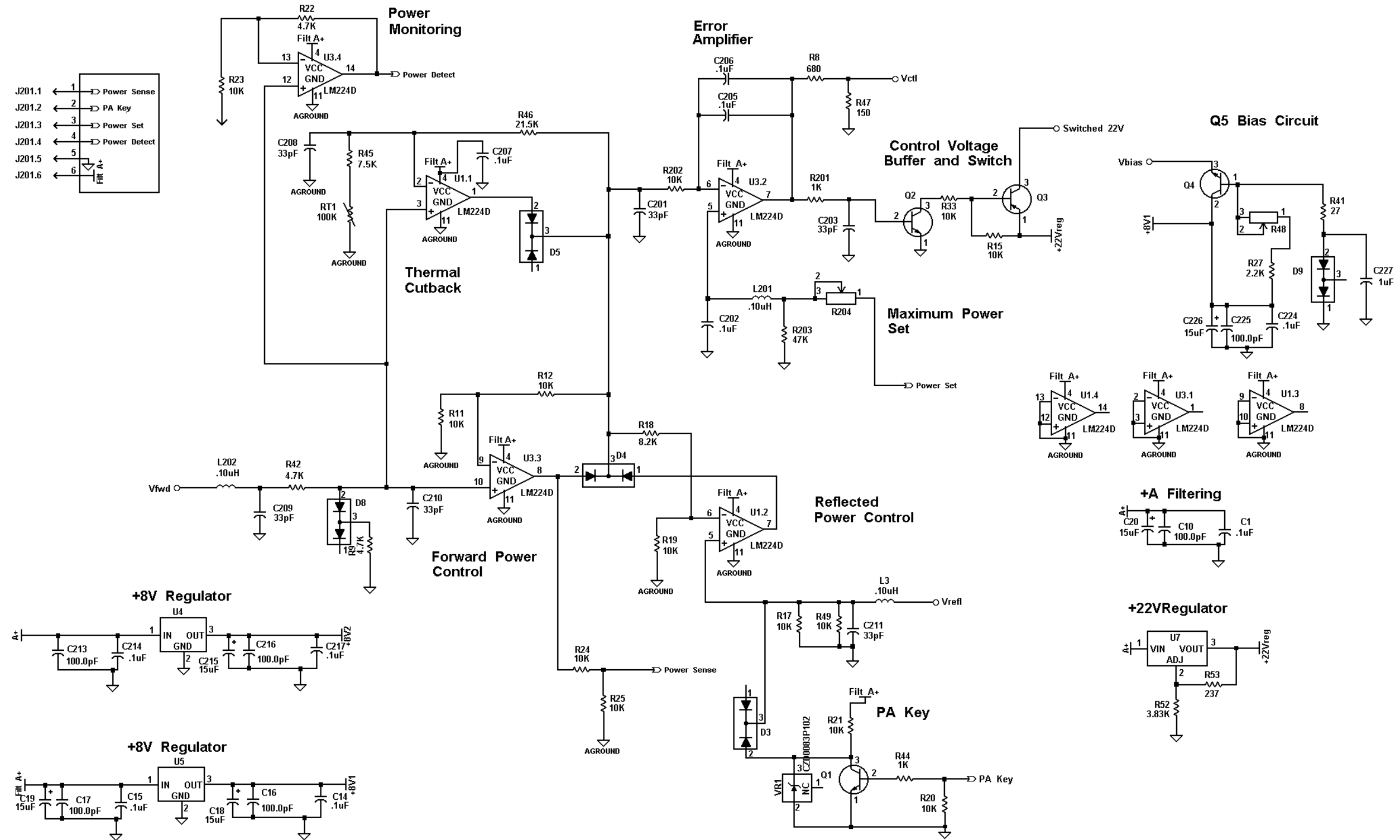

**POWER AMPLIFIER BOARD A1
19D902794G5**

(188D5792, Sh.2, Rev. 6)