

Maintenance Manual

GETC™ TRUNKING CARD

19D901868G5 and G6

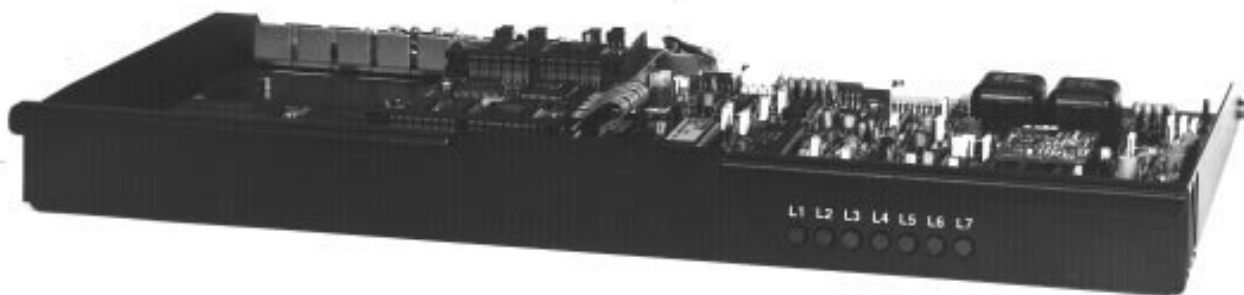

TABLE OF CONTENTS

| | |
|--------------------------------------|-----------|
| LOGIC BOARD, 188D6500G1 and G4 | Included |
| REGULATOR ASSEMBLY, 19C336816G2..... | Included |
| GETC FILTER BOARDS | LBI-39204 |
| TURBO BOARD 19D903536 | LBI-38822 |

NOTE

RADIO FREQUENCY INTERFERENCE

This equipment has been tested and found to comply with the limits for a Class B digital device, pursuant to Part 15 of the FCC Rules. These limits are designed to provide reasonable protection against harmful interference in a residential installation. This equipment generates, uses and can radiate radio frequency energy and, if not installed and used in accordance with the instructions, may cause harmful interference to radio communications. However, there is no guarantee that interference will not occur in a particular installation. If this equipment does cause harmful interference to radio or television reception, which can be determined by turning the equipment off and on, the user is encouraged to try to correct the interference by one or more of the following measures:

- Reorient or relocate the receiving antenna (i.e., the antenna for radio or television that is "receiving" the interference).
- Increase the separation between the equipment and receiver experiencing the interference.
- Connect the equipment into an outlet on a circuit different from the equipment receiving the interference.

WARNING

No one should be permitted to handle any portion of the equipment that is supplied with high voltage; or to connect any external apparatus to the units while the units are supplied with power. **KEEP AWAY FROM LIVE CIRCUITS.**

High-level RF energy in the transmitter Power Amplifier assembly can cause RF burns. **KEEP AWAY FROM THESE CIRCUITS WHEN THE TRANSMITTER IS ENERGIZED!**

NOTICE!

This manual covers Ericsson and General Electric products manufactured and sold by **Ericsson Inc.**

NOTICE!

Repairs to this equipment should be made only by an authorized service technician or facility designated by the supplier. Any repairs, alterations or substitution of recommended parts made by the user to this equipment not approved by the manufacturer could void the user's authority to operate the equipment in addition to the manufacturer's warranty.

NOTICE!

The software contained in this device is copyrighted by **Ericsson Inc.** Unpublished rights are reserved under the copyright laws of the United States.

This manual is published by **Ericsson Inc.**, without any warranty. Improvements and changes to this manual necessitated by typographical errors, inaccuracies of current information, or improvements to programs and/or equipment, may be made by **Ericsson Inc.**, at any time and without notice. Such changes will be incorporated into new editions of this manual. No part of this manual may be reproduced or transmitted in any form or by any means, electronic or mechanical, including photocopying and recording, for any purpose, without the express written permission of **Ericsson Inc.**

EDACS and MASTR are registered trademarks, and GETC, FailSoft, Aegis, and Guarddog are trademarks of **Ericsson Inc.**

TABLE OF CONTENTS

| <u>Section/Paragraph</u> | <u>Page</u> |
|---|-------------|
| TABLE OF CONTENTS | 3 |
| LIST OF FIGURES | 6 |
| LIST OF TABLES | 6 |
| SPECIFICATIONS* | 7 |
| RELATED PUBLICATIONS | 8 |
| INTRODUCTION | 9 |
| IDENTIFICATION | 9 |
| DESCRIPTION | 10 |
| CONTROLS AND INDICATORS | 10 |
| Front Panel Indicators | 10 |
| Controls | 10 |
| OPTIONS | 10 |
| Turbo Board..... | 10 |
| ROCKWELL MODEM BOARD | 11 |
| INTERFACE POINTS | 12 |
| GETC COMMUNICATION LINKS | 12 |
| CIRCUIT ANALYSIS | 13 |
| GETC LOGIC BOARD | 13 |
| Reset Circuitry | 13 |
| Clock Circuitry | 16 |
| Jumper Configuration | 16 |
| Switch Settings..... | 16 |
| Power Supplies And Regulators..... | 17 |
| Logic | 18 |
| Low-Speed Data Encode Filter | 19 |
| Low-Speed Data Decode Filter..... | 19 |
| High-Speed-Data Transmit Filter..... | 21 |
| High-Speed Data Detector | 22 |
| 9600 Baud Modem Board And Telephone Line Interface | 22 |
| INTERFACE | 24 |
| STATION CONTROL INTERFACE | 24 |
| Synthesizer-Exciter Board Interface | 24 |
| Data Load To Synthesizer-Exciter | 24 |
| Station Control Interface..... | 25 |
| SITE CONTROLLER INTERFACE | 26 |
| Transmit Data | 26 |
| Receive Data | 27 |
| FAILSOFT INTERFACE | 28 |
| BSL Receive Link..... | 28 |
| BSL Transmit Link | 28 |
| Frame Sync Line | 28 |
| PERSONALITY PROGRAMMING | 29 |
| Programming a Personality Using TQ-3357 V3 (or earlier) | 30 |
| Programming a Personality Using TQ-3357 Version 4.03 (or later) | 31 |

TABLE OF CONTENTS

| <u>Section/Paragraph</u> | <u>Page</u> |
|---|-------------|
| MAINTENANCE | 32 |
| SUBASSEMBLY REMOVAL AND REPLACEMENT | 32 |
| Replacing a 19D904266 or 19D902104 Logic Board..... | 32 |
| Replacing a 188D6500Gx Logic Board | 33 |
| Turbo Board..... | 33 |
| Rockwell Modem | 34 |
| Power Supply, A2 | 34 |
| TEST AND ALIGNMENT | 35 |
| GETC TESTING | 35 |
| Test Equipment Required..... | 35 |
| Terminal Connection..... | 35 |
| Software Requirements | 36 |
| Test Preparation | 37 |
| POWER SUPPLY TEST | 38 |
| LOGIC BOARD TEST | 38 |
| Serial Link Test..... | 38 |
| Modulation Setting Test (R31)..... | 38 |
| EPROM Check (U2) | 40 |
| RAM Test (U3) | 40 |
| Microprocessor Oscillator Test (Part of U19)..... | 40 |
| Reset Circuit Test (U17B)..... | 40 |
| Watchdog Timer (U4) Test | 40 |
| Transmit and Receive Data Test | 40 |
| Octal Latch (U38) Output Test..... | 41 |
| Low Speed Handshaking Test..... | 41 |
| DIP Switch Test (S1, U8, S2, U9, S3, U7) | 42 |
| 4800 Baud Divide by 2 Circuit (U41)..... | 42 |
| Phone Modem Test (U19)..... | 42 |
| Output Latches And Buffers Test (U20 &U21) | 43 |
| Input Buffer And Port Pins Test..... | 45 |
| ROCKWELL MODEM TEST..... | 46 |
| Comparator Test (U31-B) | 46 |
| Transmit Clock Test..... | 47 |
| FSL & BSL Drive Test | 47 |
| Guarddog Test..... | 47 |
| TROUBLESHOOTING..... | 48 |
| ON SITE TROUBLESHOOTING..... | 48 |
| IN CASE OF DIFFICULTY..... | 48 |
| MODIFICATIONS | 49 |
| GUARDDOG AUTOMATIC RESET | 49 |
| Installation..... | 49 |
| MICROPROCESSOR RYT 121 6060..... | 49 |
| Installation..... | 49 |
| LIGHTNING PROTECTION GROUNDING..... | 49 |
| IC DATA | 51 |
| PARTS LIST..... | 60 |
| GETC SHELF ASSEMBLY 19D901868G5 and G6 | 60 |

TABLE OF CONTENTS

| <u>Section/Paragraph</u> | <u>Page</u> |
|---|--------------------|
| GETC Logic Board 188D6500G1 and G4 | 60 |
| Regulator Assembly 19C336816G2 | 64 |
| GETC LIGHTNING PROTECTION GROUNDING KIT 344A4500G1 | 64 |
| ASSEMBLY DIAGRAM..... | 65 |
| GETC SHELF ASEMBLY..... | 65 |
| REGULATOR ASEMBLY | 66 |
| OUTLINE DIAGRAM | 69 |
| SCHEMATIC DIAGRAM | 70 |

LIST OF FIGURES

| <u>Figure</u> | <u>Title</u> | <u>Page</u> |
|---|--------------|-------------|
| Figure 1 - Typical GETC Shelf With Logic Board, Regulator Assembly, and Turbo Board | | 9 |
| Figure 2 - GETC Front Panel Indicators | | 10 |
| Figure 3 - Turbo Board..... | | 11 |
| Figure 4 - Reset Circuit | | 13 |
| Figure 5A - Simplified GETC Block Diagram | | 14 |
| Figure 5B - Simplified GETC Block Diagram | | 15 |
| Figure 6 - Clock Circuit..... | | 16 |
| Figure 7 - DIP Switches Shown in Programming Mode..... | | 17 |
| Figure 8 - Five-Volt Regulator Circuit | | 17 |
| Figure 9 - Oscillator/Inverter Regulated ± 12 V Power Supply Circuit..... | | 17 |
| Figure 10 - Low Speed Data Encode Filter | | 19 |
| Figure 11 - LSD Encode/Decode Filter Response..... | | 19 |
| Figure 12 - Low Speed Data Decode Filter | | 20 |
| Figure 13 - LSD Decode Filter Response Using ROA 117 2238 Filter Board..... | | 20 |
| Figure 14 - High Speed Data Transmit Filter | | 21 |
| Figure 15 - High Speed Data Detector | | 22 |
| Figure 16 - Rockwell Modem and Telephone Interface | | 23 |
| Figure 17 - GETC Data Sent To Site Controller | | 26 |
| Figure 18 - Site Controller or BSL Data Sent To GETC..... | | 27 |
| Figure 19 - Frame Sync Line Circuit | | 28 |
| Figure 20 - System Hook-Up Using J100..... | | 30 |
| Figure 21 - System Hook-Up Using J104..... | | 31 |
| Figure 22 - Terminal-to-GETC Connection Cable | | 36 |
| Figure 23 - Station GETC (188D6500) Jumper and Test Point Locations..... | | 39 |
| Figure 24 - Lightning-Protection Kit Installation Detail..... | | 50 |
| Figure 25 - Lightning-Protection Kit Cabinet Installation | | 50 |

LIST OF TABLES

| <u>Figure</u> | <u>Title</u> | <u>Page</u> |
|--|--------------|-------------|
| Table 1 - Interface Connections..... | | 12 |
| Table 2 - Device Addresses | | 18 |
| Table 3 - Decoding Scheme | | 27 |
| Table 4 - Indicators in Programming Mode Using J100..... | | 30 |
| Table 5 - Indicators in Programming Mode Using J104..... | | 31 |
| Table 6 - GETC and RS-232C Pin Assignments | | 36 |
| Table 7 - GETC Logic Board Jumper Configuration | | 37 |

SPECIFICATIONS*

| <u>ITEM</u> | <u>SPECIFICATION</u> |
|--------------------------------|---|
| INPUT VOLTAGE | +13.8 \pm 20% Vdc |
| CURRENT DRAIN | |
| Without 9600 baud modem | 900 mA (typical), 1.5 A (maximum) |
| With 9600 baud modem | 1.5 A (typical), 2 A (maximum) |
| OPERATING TEMPERATURE | -22°F to + 140°F (-30°C to + 60°C) |
| DIMENSIONS (H x W) | 1.75 x 19 inches (4.5 x 48.3 cm) |
| DATA TRANSMISSION | |
| High Speed | 9600 \pm 1 bps (EDACS Wideband) 4800 \pm 1 bps (EDACS Narrow band) |
| Low Speed | 150 \pm 1 bps |
| COMMUNICATION INTERFACE | |
| Site Controller (Trunked) | |
| Protocol | RS-232C |
| Data Format | 1 start bit, 1 stop bit, and 8 data bits |
| Data Rate | 19.2 kilobaud |
| Back-up Serial Link (Failsoft) | |
| Data Levels | 0 to 13.8 Vdc swing (nominal) |
| Data Format | 1 start bit, 1 stop bit, and 8/9 data bits |
| Data Rate | 19.2 kilobaud |

* These specifications are intended for use during servicing. Refer to the appropriate Specification Sheet for the complete Specification.

RELATED PUBLICATIONS

The GETC is used in several applications, which broadly includes voting, Enhanced Digital Access Communications Systems (EDACS™), Aegis, and Digital Voice. In each of these applications the same GETC is used, however, the Logic Board operates differently because of different jumper configurations, interfacing hardware, and software. Refer to the appropriate technical manual for additional information on each application.

| | | | |
|-----------|---|-----------|---|
| LBI-33031 | - Rockwell Modem 19A705178 (Model R96FT) | LBI-38986 | - GETC Conventional Network Interface (CNI) Configuration Manual |
| LBI-31981 | - Digital Voice Voting Tone Board Maintenance Manual | LBI-38987 | - EDACS Single Channel Autonomous Trunking (SCAT) GETC and Downlink GETC Configuration Manual |
| LBI-38462 | - EDACS Voter Interface Board Maintenance Manual | LBI-38988 | - EDACS Station GETC Configuration Manual |
| LBI-38822 | - Turbo Board (GETC 1e) Maintenance Manual | LBI-38989 | - EDACS Test Unit and Alarm Interface (TUAI) GETC Configuration Manual |
| LBI-38984 | - GETC Trunking Card 19D904266G1 and G4 Maintenance Manual | LBI-39004 | - EDACS Guarddog Installation and Operation Manual |
| LBI-38174 | - GETC Trunking Card 19D902104G1 Maintenance Manual | SRN-1002 | - Software Release Notes for GETC 1e Software, 19A149256G() |
| LBI-38896 | - EDACS Site Downlink and CEC/IMC Uplink Configuration Manual | SRN-1010 | - Software Release Notes for GETC Turbo Board Software (344A4414G1 only) |
| LBI-38954 | - EDACS Voter Digital Receiver and Selector GETC Configuration Manual | SRN-1024 | - Software Release Notes for GETC 900 MHz Software, 19A705595G() |
| LBI-38985 | - EDACS Site Controller Maintenance Manual | SRN-1060 | - Software Release Notes for GETC 1e Software, 349A9607G() |
| | | SRN-1061 | - Software Release Notes for Link Software, 344A4895G1 (or later) and Link Turbo Software 350A1121G4 (or later). |
| | | SRN-1062 | - Software Release Notes for GETC Turbo Board Software (344A4414G2 or later) |
| | | TQ-3357 | - GETC Shelf Programming Manual |

INTRODUCTION

This manual contains maintenance and servicing information for the Ericsson **GE Trunking Card (GETC)** Shelf Assembly 19D901868G5 and G6. Typically, all production models of the shelf consist of the following subassemblies:

- Shelf 19C851587G1
- Logic Board (A1) 188D6500G1 or G4
- Regulator Assembly (A2) 19C336816G2
- Turbo Board 19D903536G1

IDENTIFICATION

To properly identify the board, locate the “PL” number

silk-screened on the logic board. Look for the designation (as shown below) on the left side of the logic board, toward the front of the GETC shelf, and just below the three DIP switches.

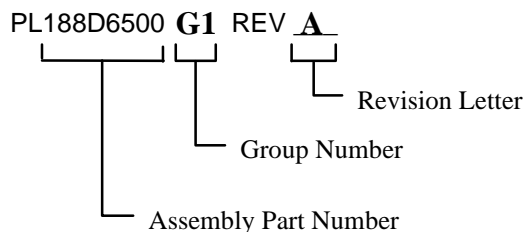

Use the Assembly Part Number to determine the applicable maintenance manual. A Revision Letter stamped on the board indicates an improvement or production change. Refer to the Production Change section (located after the Parts List) for a description of the changes and affected parts.

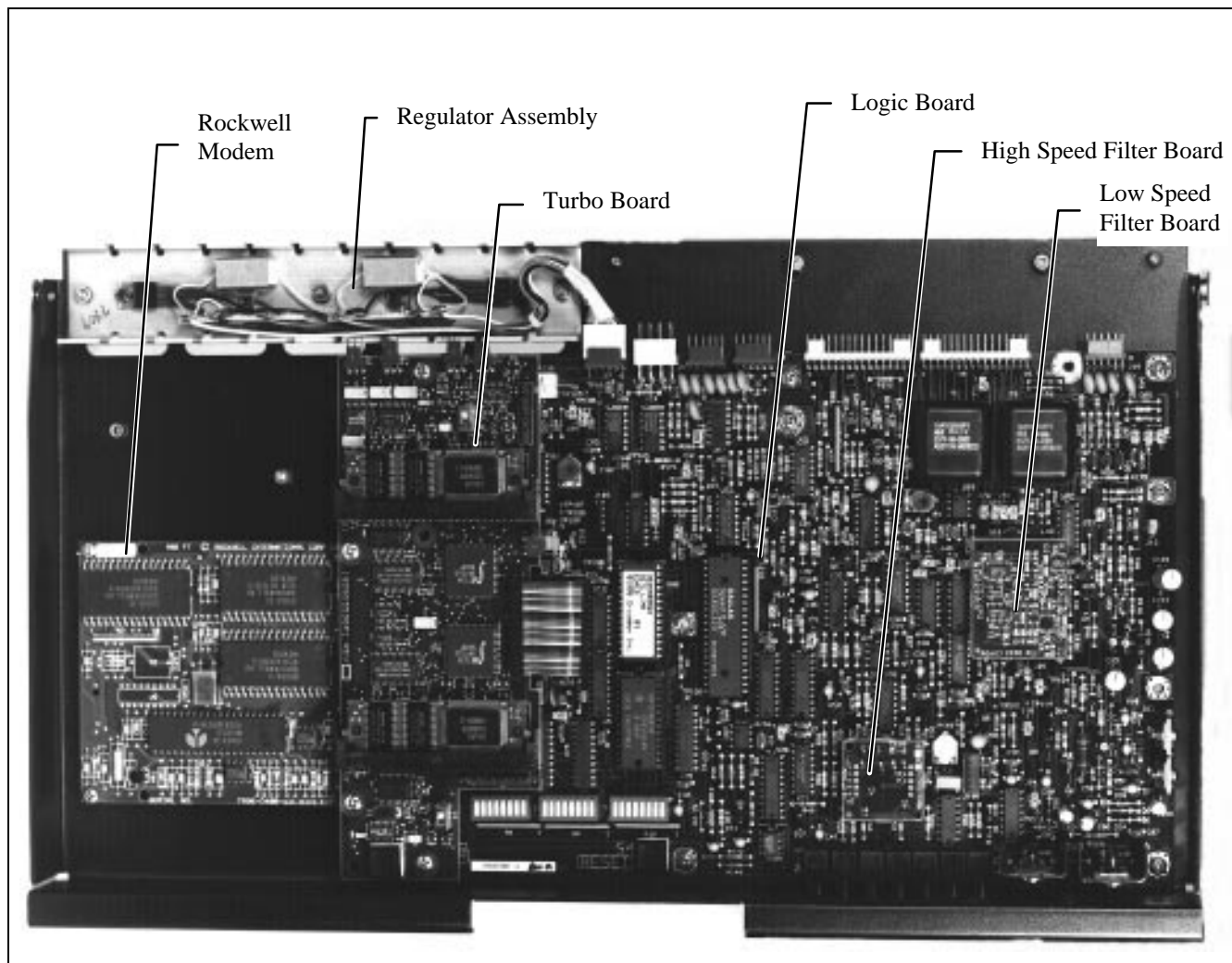

Figure 1 - Typical GETC Shelf With Logic Board, Regulator Assembly, and Turbo Board

DESCRIPTION

The GETC is essentially a processor board with audio filtering and specialized I/O capability. Because of this flexibility in design, the GETC can be integrated into many applications.

The Logic Board, Regulator Board, Turbo Board, and Modem are mounted on a tray and enclosed in a slide-out shelf as shown in Figure 1. The GETC Shelf is a one-rack-unit assembly (1.75-inches x 19-inches) which is mounted in a standard 19-inch wide equipment cabinet.

The GETC Logic Board uses Metal-Oxide Varistors (MOV's) for lightning protection on all RS-232C inputs and outputs. However, maximum lightning protection is achieved when the GETC is grounded to the cabinet earth-ground using the GETC Lightning-Protection Circuitry Grounding Kit 344A4500 and the Cabinet Grounding Strap Kit 344A4730. Specific details for installing these grounding kits are found in the Modifications section of this manual.

CONTROLS AND INDICATORS

This section describes the controls and indicators for the GETC.

Front Panel Indicators

The following controls and indicators are on the GETC Logic Board. Refer to Figure 22.

- L1 thru L7 - The seven front panel LED indicators (L1 thru L7) display the state of operation of the GETC. The interpretation of the indicators depends on the system application (refer to the configuration manual for the specific application).

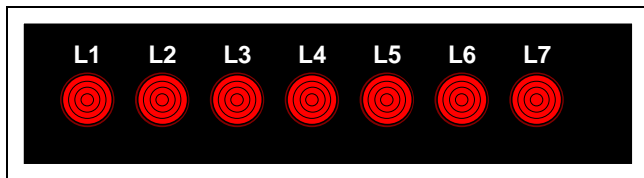

Figure 2 - GETC Front Panel Indicators

Controls

The following controls are found on the GETC board as shown in Figure 1:

- S1, S2, S3 (DIP Switches) - Used to set the GETCs operating mode and parameters.
- S4 (RESET) - Pushbutton S4 allows the technician to manually reinitialize the GETC.

OPTIONS

Depending on the application, the GETC may be equipped with one or more of the following optional boards:

- Turbo Board..... 19D903536P1
- Rockwell Modem Board 19A705178
- Low Speed Data Filter..... ROA 117 2238
- High Speed Data Filter..... See below
 - ROA 117 2237/1 - 9600 Baud, Wide Band
 - ROA 117 2237/2 - 4800 Baud, Narrowband
 - ROA 117 2237/3 - ETSI Wide Band
 - ROA 117 2237/4 - ETSI Narrow Band
 - ROA 117 2314/1 - 9600 Baud, Narrow Band

NOTE

GETCs with the “MODIFIED FOR EUROPEAN OPERATION” label must use High Speed Filter ROA 117 2237/3 or /4 to be ETSI (European Technical Standards Institute) compliant for adjacent channel power requirements. Refer to LBI-39204 for technical details on the High Speed filter boards.

In addition to optional boards, the GETC may be equipped with different or modified interface cables. Consult the specific GETC installation manual and application specific manuals whenever field maintenance is performed on the GETC.

Turbo Board

The Turbo Board, shown in Figure 3, provides the GETC with additional processing power and memory. The Turbo Board is connected to the GETC via a ribbon cable from J1 on the Turbo Board to the XU3 socket on the GETC Board.

Since the Turbo Board is used to store the GETCs personality programming, U35 is no longer required and is normally removed from the GETC.

The following controls and indicators are located on the Turbo Board:

- S1 (RESET) - Pushbutton S1 allows the technician to manually reinitialize the Turbo Board.
- S2 and S3 - Slide switches S2 and S3 are used to select the run or load mode for Turbo Board microprocessors U1 and U2, respectively.

- D1 and D2 - Indicate whether the Turbo board microprocessors are in the programming (OFF) or run (ON) mode.

ROCKWELL MODEM BOARD

The 9600 Baud Rockwell Modem Board, 19A705178, is used in the GETC shelf to generate a fast-train, synchronous, serial data stream suitable for transmission over audio (phone) lines or microwave. The data stream is sent to a full-duplex, four-wire, dedicated 3002 grade telephone line.

Receive and transmit Phone Line Data lines (J6-6,7,8,9,) are two balanced pairs carrying Modem data to and from the station where the data is combined with station (voice) audio and routed to the Remote Line input and Line output.

In addition to the GETC provided transformer isolation and conditioning, the modem provides automatic adaptive signal equalization allowing normal operation using input signal levels from -40 dBm to 0 dBm. The Rockwell Modem demodulates the input signal and the resulting data is transferred using a serial interface between the Rockwell Modem and GETC. The physical connections for the interface are at J3C-22, J11-1, J11-2, and U19-19.

The modem senses a received signal by initiating a training state upon detecting an increase in the input signal level. The modem begins processing data at the end of the training state if the input signal is still above the nominal -40 dBm receiving threshold value. Otherwise, the modem returns to an idle mode at the end of the training state if the input signal is below the nominal receiving threshold value.

The duration of the modem's training state is determined through GETC control signals at the time of power up. Resetting the GETC (pressing S4) or cycling the GETC Shelf's operating power initializes the Rockwell Modem for proper operation.

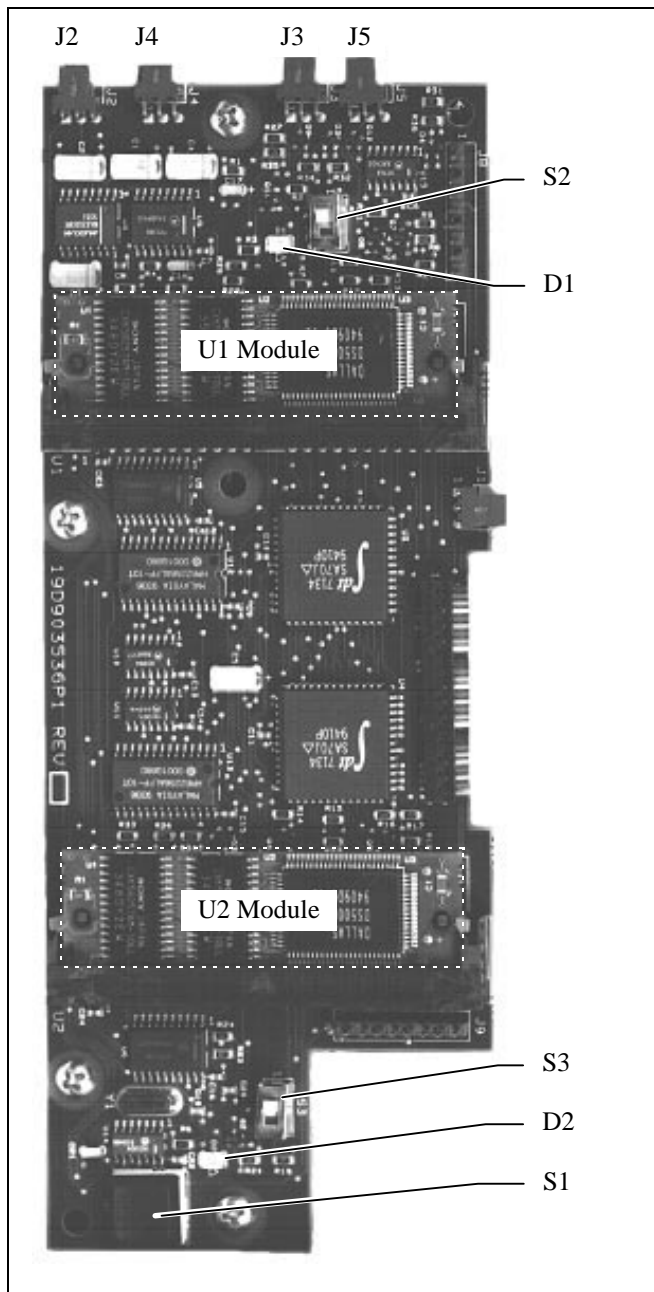

Figure 3 - Turbo Board

INTERFACE POINTS

There are ten connectors on the GETC board used for interface connections. These connectors are identified in Table 1.

Table 1 - Interface Connections

| Connector | Interface Connection |
|-----------|--|
| J3 | 9600 baud (Rockwell Modem) Interface. |
| J27 | Regulator board interface. |
| J49 | Voting board interface. |
| J10 | 13.8 Vdc power connection |
| J9 | External modem interface |
| J8 | Site Controller interface |
| J7 | RF station interface |
| J6 | RF station interface |
| J19 | Site Controller interface |
| XU3 | Turbo Board Interface |
| J102/J103 | Low Speed Filter Board Interface |
| J100/J101 | High Speed Filter Board Interface |
| J104/J105 | PLL Board Interface |
| J106 | Remote Reset and Failsoft Monitor (Guardog™) |

GETC COMMUNICATION LINKS

The following are communication modes available to the GETC:

- (1) The GETC can communicate with other devices such as the Site Controller, IMC, and RF station. Communication occurs primarily through an RS-232C serial interface normally operating at 19.2 kilobaud. For GETCs interfacing with a SIM (Site Interface Module) this is set to 38.4 kilobaud.
- (2) The GETC can communicate with other GETCs, in the Failsoft mode of operation, over a backup serial link (BSL). The link uses 0-13.8 Vdc levels and operates at 19.2 kilobaud and is ordinarily used in a bus configuration. For GETCs interfacing with a SIM (Site Interface Module) this is set to 38.4 kilobaud.
- (3) A timing signal called the Frame Sync Line (FSL) helps arbitrate the use of the BSL serial bus in the Voter configuration. The FSL is also used for timing purposes. In the Station configuration, FSL signals use 0-13 Vdc levels to produce a periodic negative going pulse.
- (4) A 9600/4800 baud full-duplex, synchronous communication interface over an RF channel.
- (5) A 9600 baud phone line or microwave communication interface (this may be RS232 or modem data) through a Rockwell modem.

NOTE

GETC interface functions vary from application to application and between EDACS systems using a MASTR II or MASTR III repeaters. Therefore, it is necessary to refer to the application's configuration manual for details regarding the specific hardware and software configuration of the GETC.

CIRCUIT ANALYSIS

Theory of operation for each circuit card assembly and module used in GETC shelf is described in the following paragraphs. Refer to the schematic diagram 188D6822 and block diagram (Figure 5).

GETC LOGIC BOARD

The logic board contains all GETC functions except the power supply, Rockwell Modem, and Turbo processor and memory.

Reset Circuitry

The GETC Logic board contains a Power-on/Manual reset for initializing the programmed code and hardware devices on the board. The reset circuit (Figure 4) consists of a comparator U17B, Zener diode D9, RESET switch S4, driver Q2, and associated circuitry.

A GETC reset may be initiated in one of five ways:

1. During power-on.
2. By manually pressing S4.
3. By the watchdog timer in U4.
4. By a constant low from an external device.
5. By a momentary low from an external device.

During power-on, the comparator U17B compares the +5.0 Vdc line with a reference level to generate a reset to the GETC logic board.

A reference level of 2.7 Vdc is set up on pin 6 of the comparator by Zener diode D9. After power-up, the steady-state level on pin 5 is set to 3.2 volts by the resistor divider (R17 and R19). The output of comparator U17B is pulled up through resistor R20. Normally, Q2 is on and the base-emitter junction clamps U17-7 to +0.8 Vdc.

When the RESET button S4 is pressed, U17-5 goes to ground and the comparator output (U17-7) goes to zero (0) volts (nominal logic 0) turning transistor Q2 off. The collector of Q2 is pulled high by R21, sending a pulse to the reset input (RES IN) of the modem (U4-25). The modem RES OUT line (U4-3) is the logical-OR of the RES IN line and the internal watchdog-timer pulse (if not serviced by microcomputer U1).

The reset out (RES OUT) of the modem is sent to the microcomputer and other logic devices on the GETC logic board. When the RESET button is released, the level on U17-5 returns to +3.2 volts after C99 charges. The comparator output (U17-7) turns off, allowing the base of Q2 to be pulled high (to 0.8 volt) as C5 charges. The time constant set up by R20 and C5, results in a 140 millisecond turn-on delay for Q2. After the reset pulse is gone, the microcomputer restarts operation from program counter address 0.

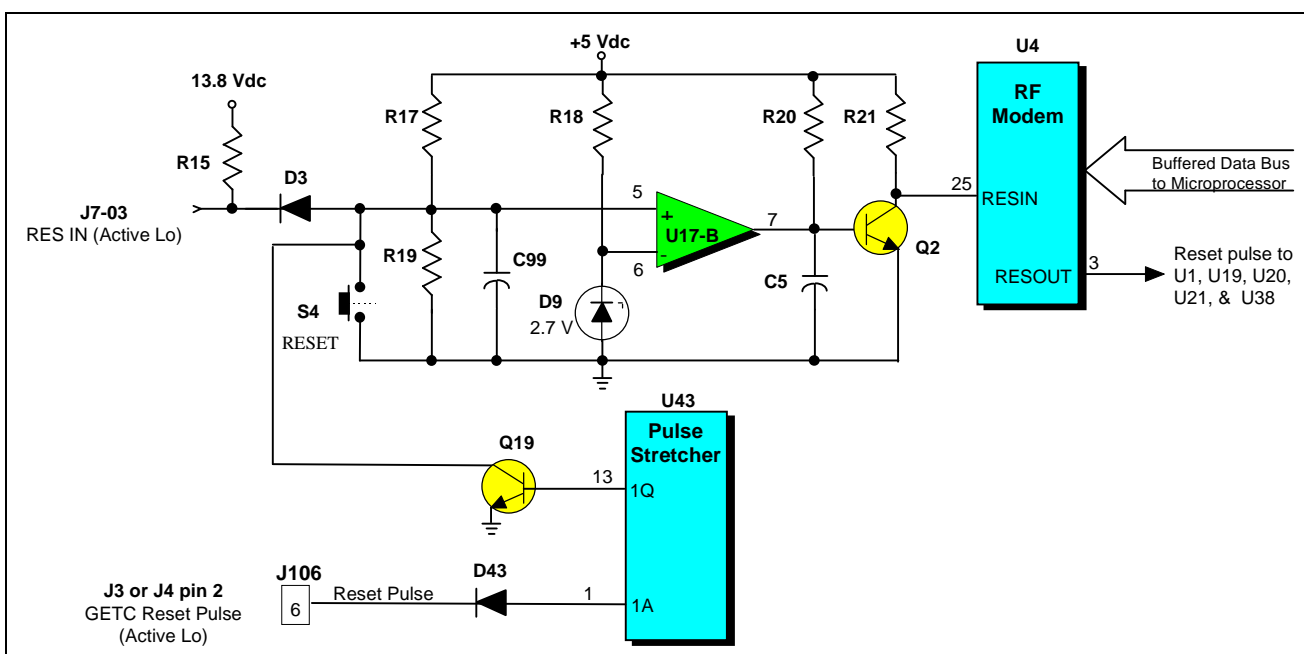

Figure 4 - Reset Circuit

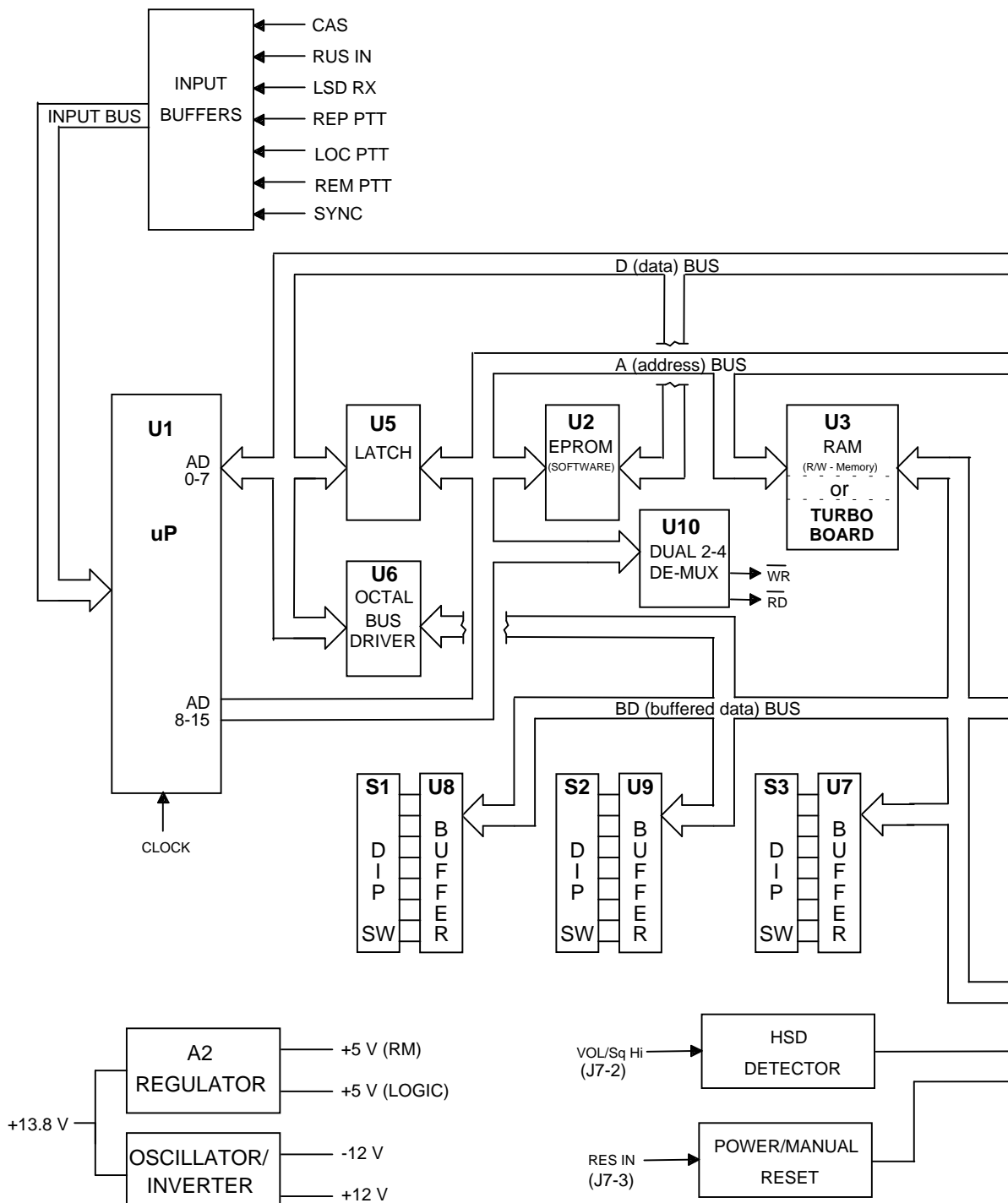

Figure 5A - Simplified GETC Block Diagram

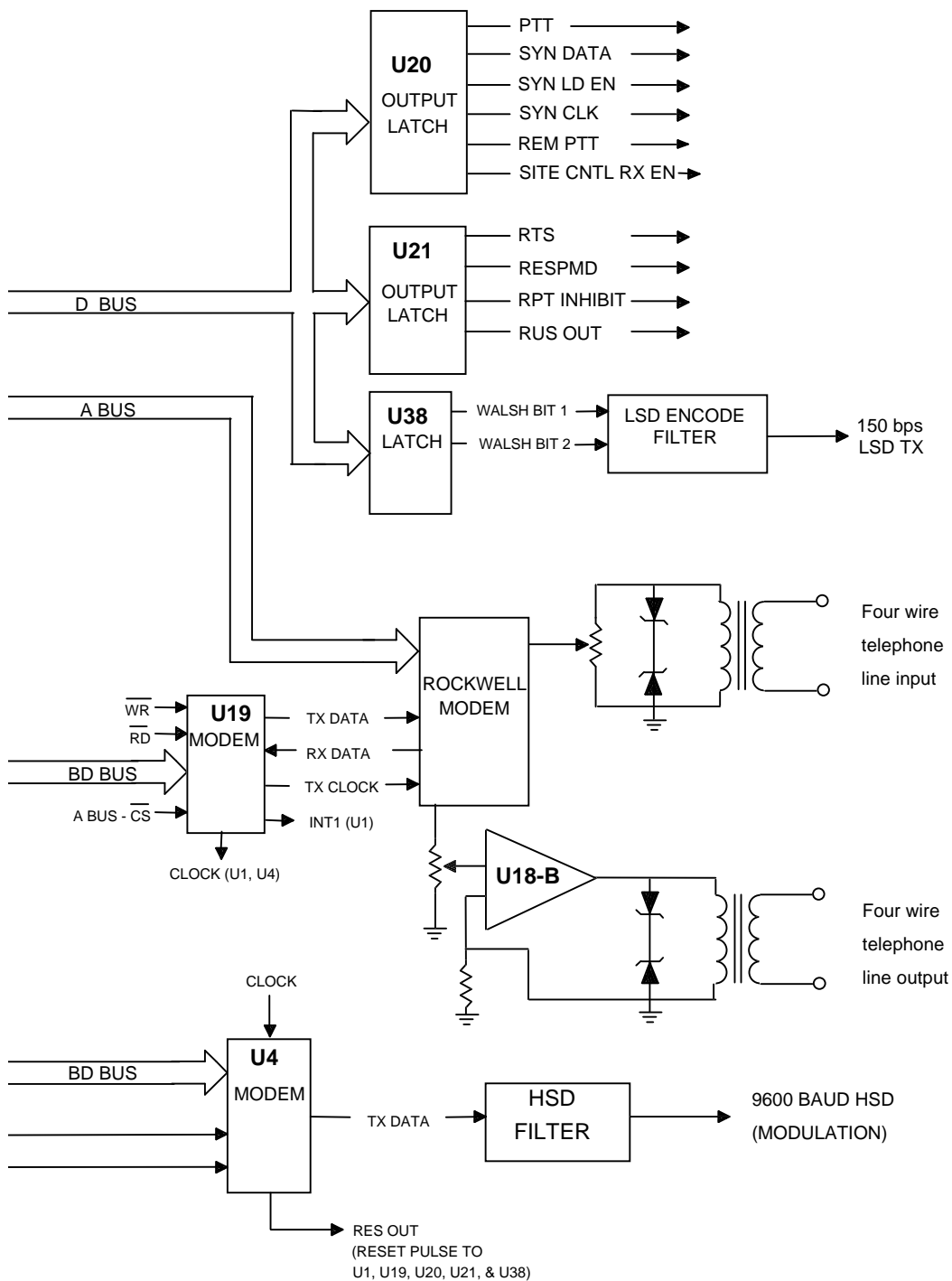

Figure 5B - Simplified GETC Block Diagram

A reset may occur automatically if the microcomputer fails to service the watchdog timer in modem U4. This reset will occur if the microcomputer misses a service for a two-second period (jumper P62 on J62 pins 1 & 2) or a four-second period (P62 on J62 pins 2 & 3).

A reset may also be generated by an external device. The external device resets the GETC by applying a logic low on J7-3, which is diode-coupled (D3) to the comparator. The reset circuit then operates as described for the RESET switch (S4).

A monetary low on J106-6 triggers one-shot U43. Its Q output goes high for approximately 100 ms, turning on Q19. Q19-C is wire OR'ed with the other RESET inputs at U17-5. From here, the RESET circuit acts just as it does for the other RESET inputs.

Clock Circuitry

The internal clock for the GETC logic board originates in Phone modem U19. The clock oscillator consists of crystal Y1, modem U19, and associated circuitry (see Figure 6). The oscillator circuit runs at 11.0592 MHz as

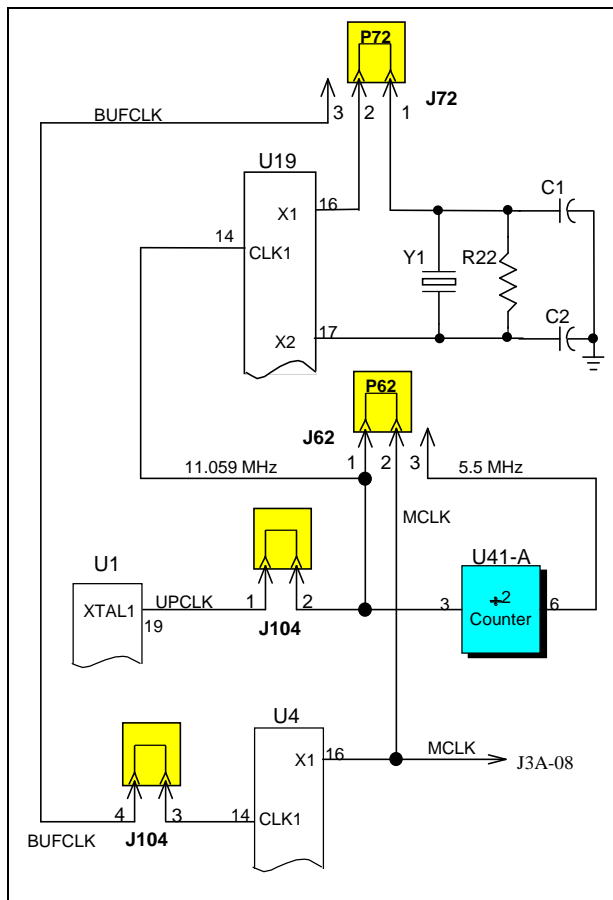

Figure 6 - Clock Circuit

determined by crystal Y1. The CLK 1 line (U19-14) output provides the clock signals to the microcomputer (U1)

For 9600 baud (wideband) operation, a jumper P62 is placed on J62 pins 1 & 2. For 4800 baud (narrowband) operation, J62 pins 2 & 3 are jumpered, this routes the clock signal through the divide-by-two counter (U41-A) to generate a 5.5296 MHz clock. The 11.0592 MHz (or 5.5296 MHz) clock signal (MCLK) from J62 pin 2 is routed to the RF modem (U4-16).

For Simulcast system operation or other applications using an external reference clock, the jumper P72 is placed on J72 pins 2 & 3 and the jumper on J62 is removed. This routes the external clock signal (MCLK) from J3A-08 to the RF data modem. The amplified output signal (BUFCLK) is then routed to the Phone modem U19-16. U19 buffers the signal which is then routed to the microprocessor U1.

Future Simulcast installations may require using the 9600 Hz signal from the T1 mux as the external clock signal. This signal will input at J19-3 and be routed to J105-4. The PLL daughter board will be installed on connectors J104 and J105. This board will develop an 11.0592 MHz clock (BUFCLK) based the external 9600 Hz reference signal. The BUFCLK signal will then be routed through J72-2 and 3 to the Phone Modem U19.

Jumper Configuration

There are several jumpers on the GETC logic board used for configuring the GETC for different applications. For the proper jumper settings , always refer to the Software Release Notes covering the specific application and software version.

NOTE

Jumper settings contained in this manual are for bench test and alignment only. Refer to applicable SRN for operational jumper configuration.

Switch Settings

There are three eight-position DIP switches (S1 thru S3) located on the GETC logic board. These switches are used to configure the GETC for different applications, such as testing, programming, or operation. Refer to the Software Release Notes for the specific application when setting the DIP switches.

NOTE
 DIP switch settings contained in this manual are for test and alignment only. Refer to applicable SRN for operational DIP switch configuration.

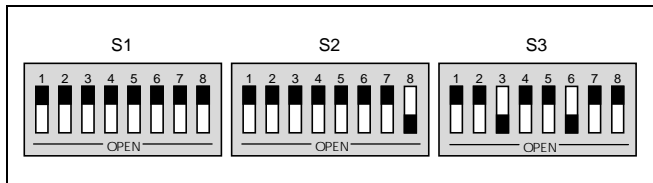

Figure 7 - DIP Switches Shown in Programming Mode

Power Supplies And Regulators

The GETC receives its primary power from the station power supply (13.8 volt nominal) through connector J10-1. Regulated +5.0 volts, +12.0 volts and the -12.0 volts are derived from this source.

Generation of the regulated +5.0 volts is accomplished through the Regulator Assembly (19C336816G2). This assembly (Figure 8) gets 13.8-volt station power through connector J27-4. Regulated +5.0 volts is returned to the GETC logic board devices through J27-6. Regulated +5.0 volts used to power the 9600 baud Rockwell Modem is

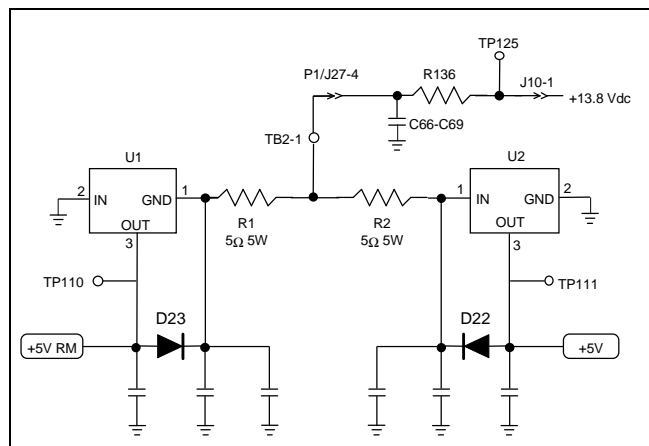

Figure 8 - Five-Volt Regulator Circuit

returned at connector J27-1.

Resistors R1 and R2 are used to lower the voltage across the regulators, reducing their dissipation. Terminal strips TB1 and TB2 serve as interconnect points for the harness (W1) that mates into the GETC logic board (P1/J27).

Regulator U2 is the power source for the GETC logic board devices, while U1 is the power source for the 9600

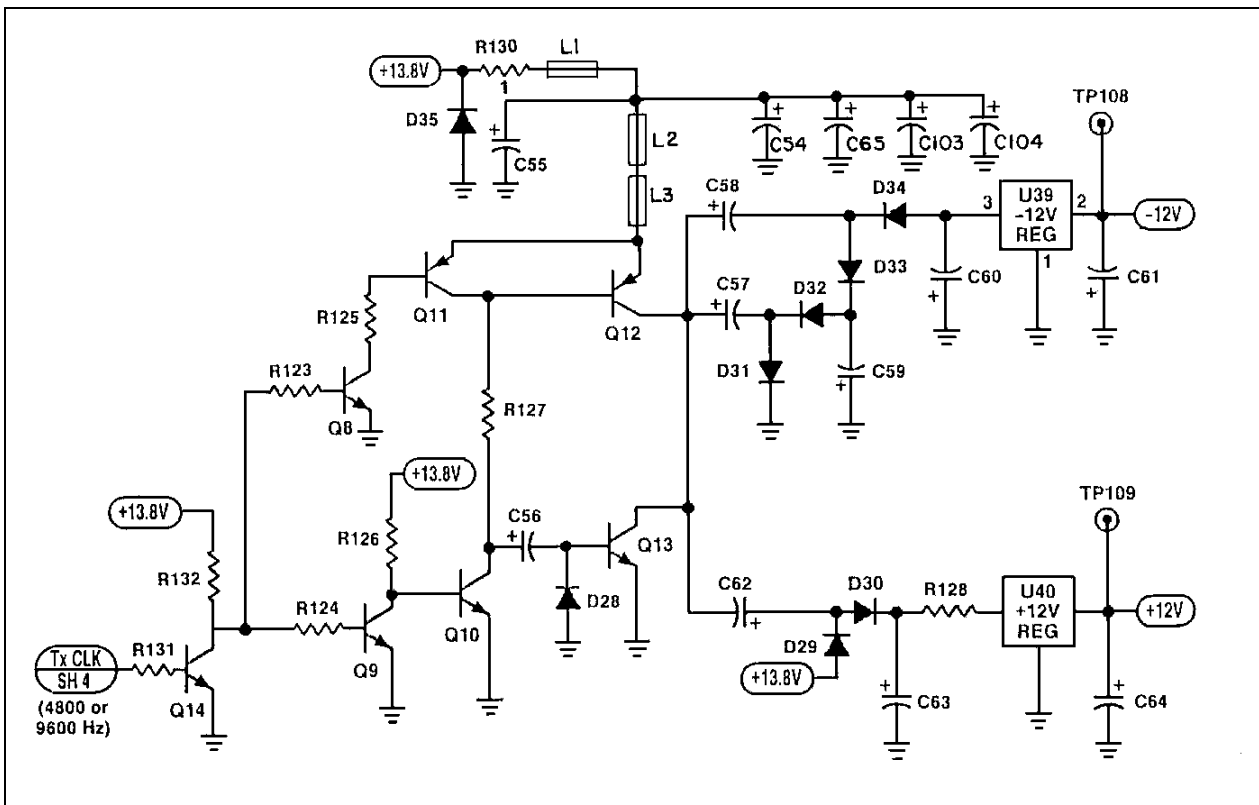

Figure 9 - Oscillator/Inverter Regulated ±12 V Power Supply Circuit

baud modem board. Ripple filtering for the +5.0 volt regulators is provided on the GETC logic board by capacitors C47 thru C49 and C51 thru C53. Diodes D22 and D23 provide back-bias protection on the +5 volt power regulators.

Regulated +12.0 and -12.0 volts are generated using the oscillator-inverter circuitry. These sources supply power to the analog circuits and RS-232C driver devices on the GETC Logic Board, as well as the 9600 baud Rockwell Modem.

The oscillator-inverter circuit, shown in Figure 9, obtains a 9600 Hz (or 4800 Hz if P62 is on pins J62-2 & 3) square wave input from modem U4-27, which is sent to the base of transistor Q14. Transistor Q14 translates the TTL square wave to a 0 to 13.8 volt square wave. Transistor Q8 and Q9 provide additional buffering to drive Q11 and Q10, respectively. Transistor Q11 and Q10 drive Q12 and Q13 to obtain a push-pull, high-level drive output. Capacitor C56 and diode D28 are used to quickly turn off Q13. The output at the collectors of transistors Q12 and Q13 is a high-drive 9600 Hz (4800 Hz if P62 is on pins J62-2 & 3) square wave which swings from 0 to 13.8 volts. Capacitors C57 thru C60 and diodes D31 thru D34 comprise a negative voltage doubler, which maintains a nominal value of -23 volts to the input of the negative voltage regulator U39. Capacitors C62 and C63, and diodes D29 and D30 comprise a positive voltage doubler, which maintains a nominal value of +25 volts to the input of the positive voltage regulator U40. Resistor R128 is used as a current limiting resistor to reduce the case temperature of regulator U40.

The two voltage regulator, U39 and U40, reduce the input voltage to obtain a regulated -12.0 volts and a regulated +12.0 volts, respectively. Capacitors C61 and C64 provide additional ripple filtering on the -12.0 and +12.0 volt lines.

Logic

The GETC Logic board provides the station control and interfacing in the system. The main controller on the GETC shelf is the microcomputer (U1) found on the GETC logic board. The microcomputer obtains its instructions from the program stored in PROM U2. The upper eight address lines of the microcomputer (U1) go directly to the PROM, while the lower address lines are latched into register U5. The output of U5 supplies the lower eight address lines to the PROM. The microcomputer accesses the data from the PROM using the control line PSEN (Program Store Enable) on U2-22. An external RAM (U3) (or Turbo Board when installed) holds data and tables. The address lines to the RAM are identical to that of PROM U2.

Microcomputer U1 accesses the Phone modem (U19) to interface to the 9600 baud Modem board or 9600 baud RS-232 link. This provides a remote data interface. The RF modem U4 provides the high-speed data encode to the station transmitter, as well as the high-speed data decode from the station receiver.

The configuration of the GETC is partly determined by the settings of DIP switches S1 thru S3. The microcomputer reads these settings via octal buffers U7 thru U9. Resistor packs R8, R9, and R39 are pull-ups for the switch lines.

The microcomputer accesses data to or from RAM (U3), Phone modem U19, RF modem U4, and octal buffers U7 thru U9, via the octal bus transceiver U6. The transceiver, when directed by the microcomputer read command (RD at U1 pin 19) transfers the data from the switches, RAM and BD (buffered data) Bus to the D(data) Bus. Data going to or from the PROM, and octal latches U20, U21, and U38 is handled by the D (data) bus.

Program memory is selected by the PSEN(-) strobe (U1-29). Address Latch Enable (ALE) addresses the devices on the A (address) bus by latching the lower eight bits of the address through U5. The upper eight bits of the address are sent directly to the devices. The two-to-four demux/decoder (U10) is used to decode the upper address lines (A11 thru A13). When gated by RD(-) or WR(-), the demux/decoder enables the desired device to transmit or receive data. The devices on the microcomputer bus are addressed according to Table 2.

Table 2 - Device Addresses

| DEVICE | HEXADECIMAL ADDRESS |
|-----------------|---------------------|
| U3 | 0000 - 1FFF |
| U4 | A170 - A172 |
| U7 | B800 |
| U8 | B000 |
| U9 | A800 |
| U19 | A0F0 - A0F2 |
| U20 | A800 |
| U21 | B000 |
| U38 | B800 |
| 9600 baud modem | A1E7 |

Low-Speed Data Encode Filter

The low-speed-data encode filter (Figure 10) is comprised of U30, U32A, U32D, and associated circuitry. This filter is a low-frequency response filter consisting of a two-stage gyrator section. The filter is used to smooth out the transitions of data which is impressed upon the voice audio. Low-speed data is a 150 bit per second data stream generated by the microcomputer, and used to produce subaudible data on the voice audio.

Low-speed data is generated by the microcomputer on Walsh bit 1 and 2 on octal register U38 (pins 2 and 5). For low-speed data, two Walsh bits are scaled and summed through the analog switch (U34C) to the input of the low-speed-data encode filter. The LSD Tx output of the filter leaves the GETC logic board on J19-5, and goes to transmitter where the filtered data is added to the voice audio. The audio (plus low-speed data) combination comes back to the GETC logic board on J7-5, where the analog and digital paths are controlled by the microcomputer through switch U15A. The frequency response of the low-speed-data encode filter is shown in Figure 11.

Low-Speed Data Decode Filter

The Low Speed Data Decode Filter is used to remove voice-audio (300-3000 Hz) leaving only the low-speed or subaudible data for input to the microprocessor.

The station receiver (demodulated) audio, VOL/SQ HI, enters the GETC logic board through connector J7-2, where it is coupled through C107 to the input to buffer U37C. C107 decouples the GETC input providing DC isolation from the receiver output. R174 is a pull up resistor biasing the input signal applied to U37C to +5 volts. This bias arrangement allows the GETC to interface with both MII or MIII stations without modification. The data is then routed to the Low Speed Data Decode Filter input, at U32B-6 and to the High Speed Data Slicer at U17A-3.

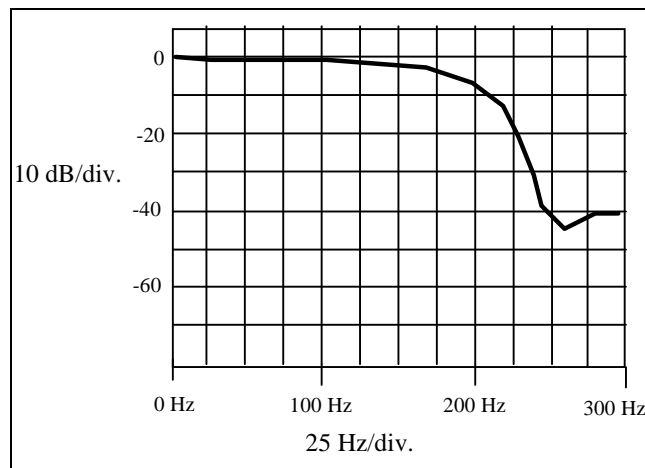

Figure 11 - LSD Encode/Decode Filter Response

The VOL/SQ HI audio is coupled through capacitor C29 to the low-speed-data-decode voice-reject filter U32B-6 as shown in Figure 12.

The GETC LSD plug-in filter, ROA 117 2238, is used in all GETC receiver applications, except CNI GETCs. The filter is a four-pole elliptic filter with a nominal bandwidth of 50 Hz and a lower frequency peak ripple response of the filter centered at 75 Hz, as shown in the filter response curve in Figure 13. This centering at a nominal 75 Hz is controlled by the filter's on-board clock (9100 Hz).

This improved filter mounts on connectors J102 and J103. Its design allows it to reject the voice audio above 300 Hz and low frequency modulation below 25 Hz. This eliminates the loss of low speed data resulting from low frequency modulation generated by some personal radios when subjected to vibration.

The output from U32B-7 is routed to the filter input at J102-1. The filtered low-speed data is routed to a limiter consisting of U31A and associated circuitry. Analog switch

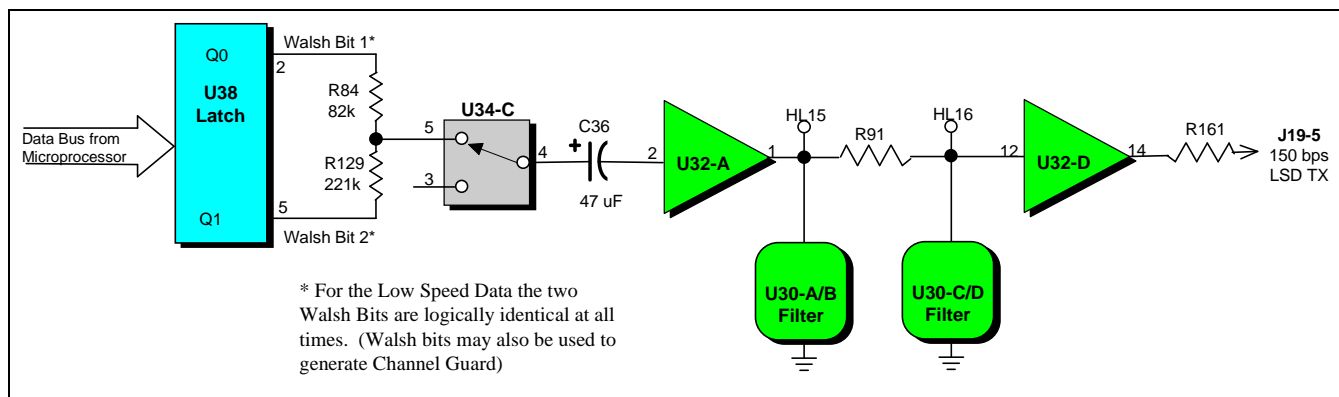

Figure 10 - Low Speed Data Encode Filter

U34B switches the low-speed data acquisition time constant from a higher rate to a slower rate. The output at U31-1 is a data waveform swinging from -12 volts to about 1 volt. This waveform is converted to a TTL waveform by Q5, and sent to buffer U11-7 and then to the microprocessor U1. The microcomputer software decodes the low-speed data.

The plug-in LSD Filter ROA 117 2238 is not used in CNI applications. This GETC application uses the on-board Low Speed Data Filter. In order to use this filter, the plug-in LSD filter must be removed (if installed) and a jumper must be installed on J103-1 & 2.

The on board LSD filter consists of U33, U32B, U32C, and associated circuitry. The filter is a low-frequency response filter, consisting of a two-stage gyrator section. It is used to reject the voice audio and obtain the low-speed data or subaudible signaling. The frequency response of the on-board low-speed-data decode filter is shown in Figure 11.

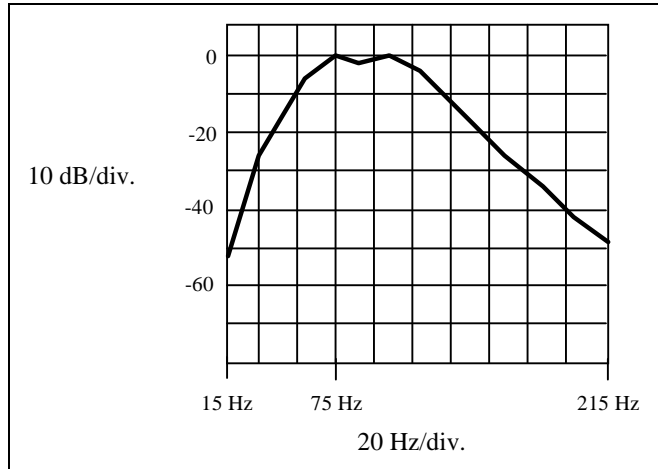

Figure 13 - LSD Decode Filter Response Using ROA 117 2238 Filter Board

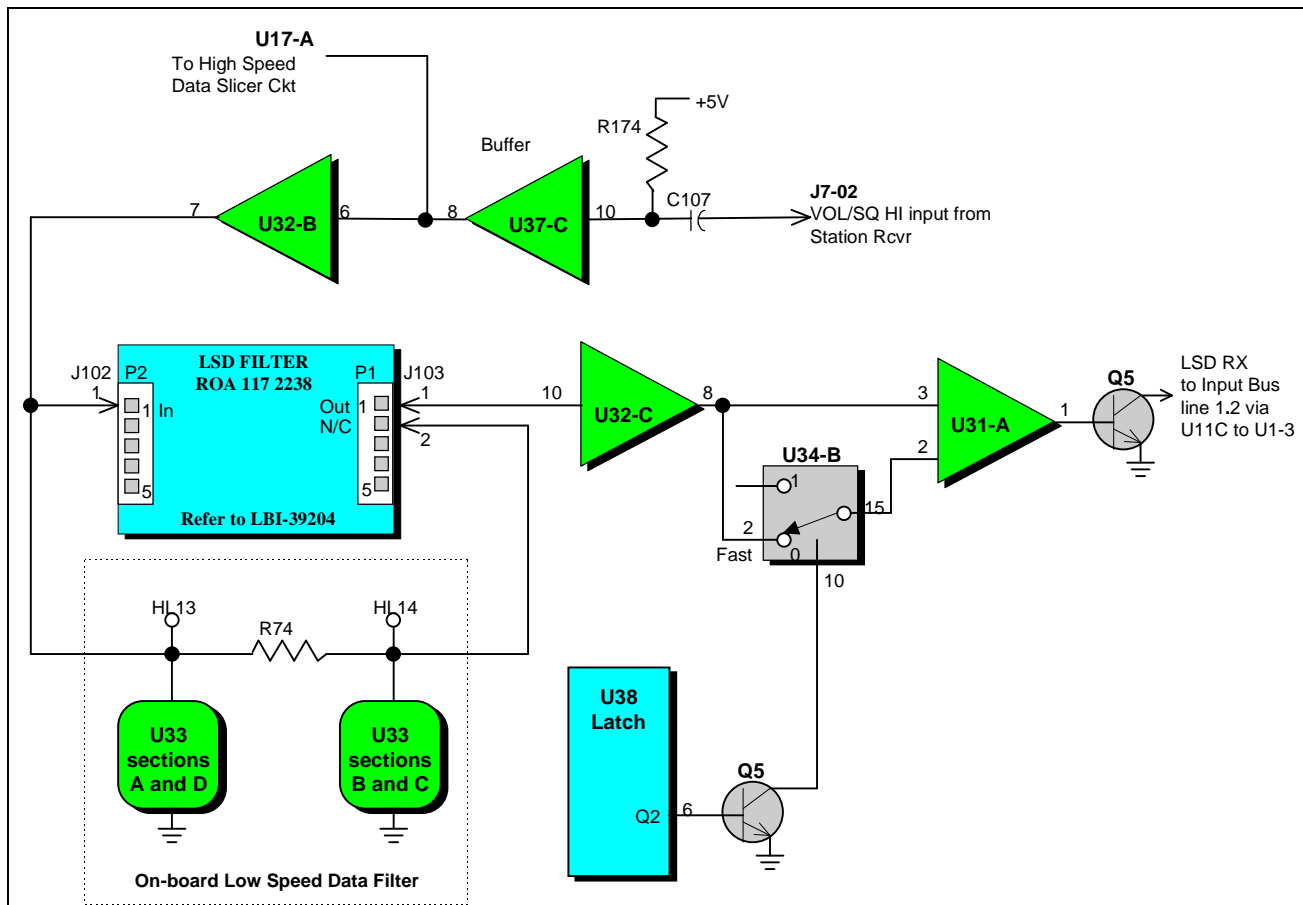

Figure 12 - Low Speed Data Decode Filter

High-Speed-Data Transmit Filter

The High Speed Data (HSD) filter is basically an active GMSK (Gaussian Minimum Shift Keying) filter that filters the data transitions to minimize the high-speed-data transmission bandwidth. The frequency response of the HSD filter section is changed by installing one of the following plug-in filters:

- ROA 117 2237/1 - 9600 Baud, Wide Band
- ROA 117 2237/2 - 4800 Baud, Narrowband
- ROA 117 2237/3 - ETSI Wide Band
- ROA 117 2237/4 - ETSI Narrow Band
- ROA 117 2314/1 - 9600 Baud, Narrow Band

NOTE

GETCs with the “MODIFIED FOR EUROPEAN OPERATION” label must use High Speed Filter ROA 117 2237/3 to be ETSI (European Technical Standards Institute) compliant for adjacent channel power requirements. Refer to LBI-39204 for technical details on the High Speed filter boards.

The high-speed-data filter (Figure 14) section consists mainly of a replaceable HSD plug-in filter board and control circuitry on the GETC Logic Board. The plug-in filters are fully described in LBI-39204.

High-speed data is a 4800 or 9600 bit per second data stream generated by the microcomputer through the RF data modem (U4).

Each of the HSD filter boards has four sections, serving as the transmit filter and buffer/driver. The output of the filter drives high speed data into switch U15A-12. (In MII and MIIe systems, audio from the TX synthesizer-exciter board is fed into J7-5 and routed to U15A-13). The MODCNTL signal, controlled by the microprocessor, switches U15A, enabling or disabling the HSD (or audio) sent to the TX modulator. When the MODCTRL is low, the HSD LED (L7) turns on indicating U15A-12 is selected and high speed data is being routed to the transmitter.

Variable resistor R31 is used to set the high-speed data deviation in the station. This is the only deviation control on the GETC logic board. The voice and low-speed data deviation is set on the synthesizer-exciter board at the station transmitter.

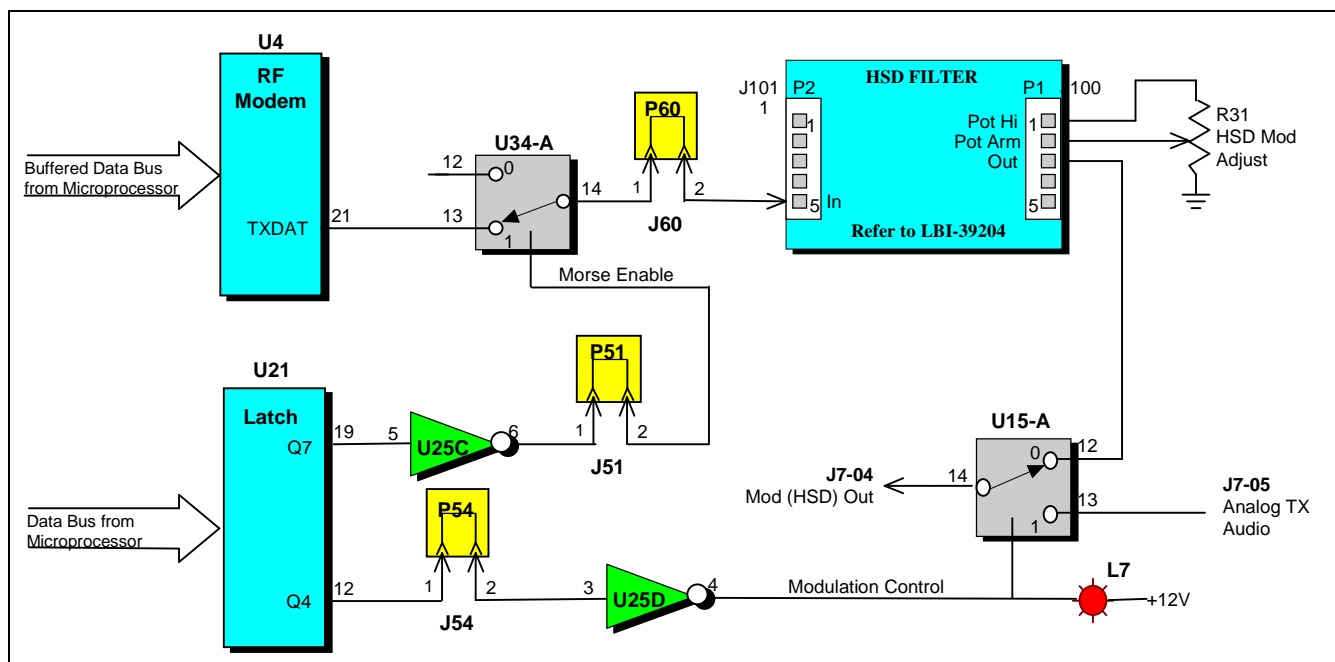

Figure 14 - High Speed Data Transmit Filter

High-Speed Data Detector

The high-speed-data detector is comprised of U17A and associated circuitry. The received input (VOL/SQ HI) enters the GETC logic board at J7-2 and is coupled to U37C-10. This signal is sent to the data limiter (U17A). The microcomputer controls the acquisition rate of the high-speed-data detector through switch U15C. A slow acquisition rate is set when the microcomputer brings U21-16 low, similarly a high on U21-16, sets the fast rate. A low on U21-16 causes a high on U15-9.

Slow acquisition rate is used if the GETC logic board has locked into mobile/portable transmissions. The fast acquisition rate is used if the GETC is looking for mobile/portable transmissions. Speeding up the acquisition rate is achieved by allowing the bias level on U17A to adapt quickly to the DC bias level on the incoming VOL/SQ HI received signal.

9600 Baud Modem Board And Telephone Line Interface

The GETC interfaces to the 9600 baud Rockwell Modem Board through connector J3. Address and control of the 9600 baud modem board is over the A bus (lower seven address lines), the BD bus, and Phone Modem U19. The microcomputer addresses the Rockwell Modem Board to set the modem board timing for external clock, and sends

data to the Rockwell Modem Board through U19. When data is to be sent, the microcomputer sends a request to send (RTS) and waits for a clear to send (CTS) from the modem board. The RTS line is sent to the modem board from latch U21-2, and is an active-low TTL signal.

The CTS signal back to the microcomputer is read on U1-15, and is an active-low signal from the modem board. The telephone line transformers T1 and T2, couple the four-wire telephone line to the Rockwell Modem Board.

Transformer T1 receives data from the telephone line and couples the data to the modem board at J3A-32. A voltage follower (U18A) drives the data to the modem board. Resistor R1 is used to adjust the telephone line level to the proper modem reference level. The reference level is 0.16 volts rms. at U18-1. Diodes D10 and D11 are used for surge protection.

Transformer T2 transmits data from the modem board to the telephone line. The serial transmit data is obtained from J3C-32, and sent to U18B for coupling to the telephone line. Resistor R2 is used to adjust the telephone line level to the proper transmit reference level. The reference level is usually 0.77 volts rms. (0 dBm) across J6-8 and J6-9 (balanced). Diodes D12 and D13 are used for surge protection.

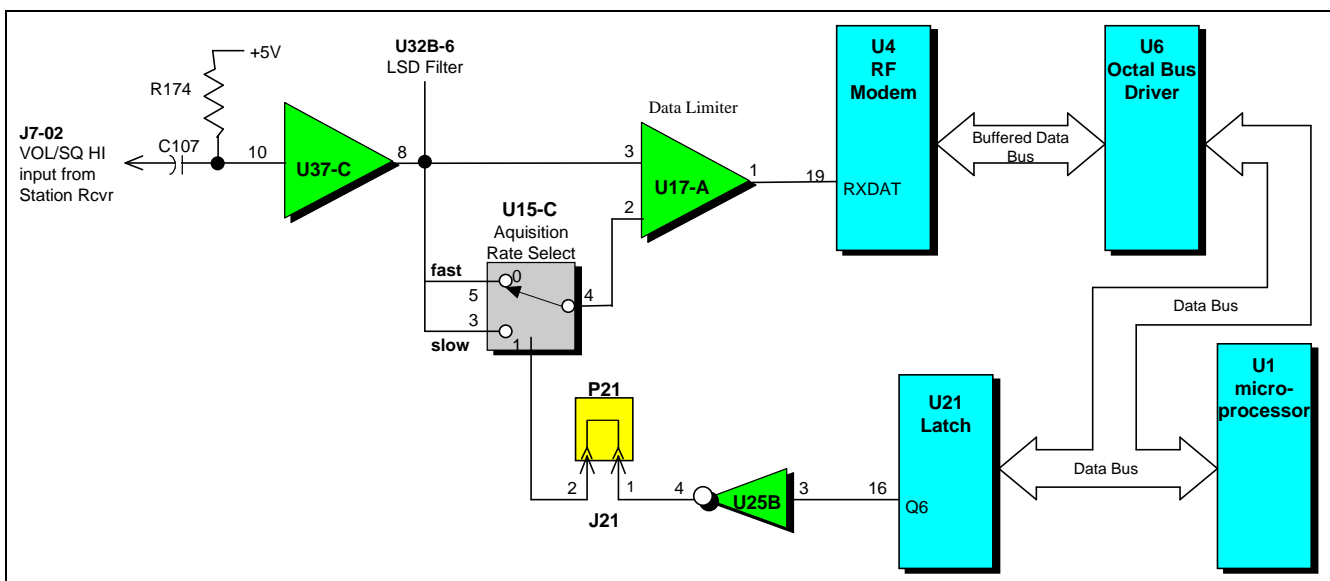

Figure 15 - High Speed Data Detector

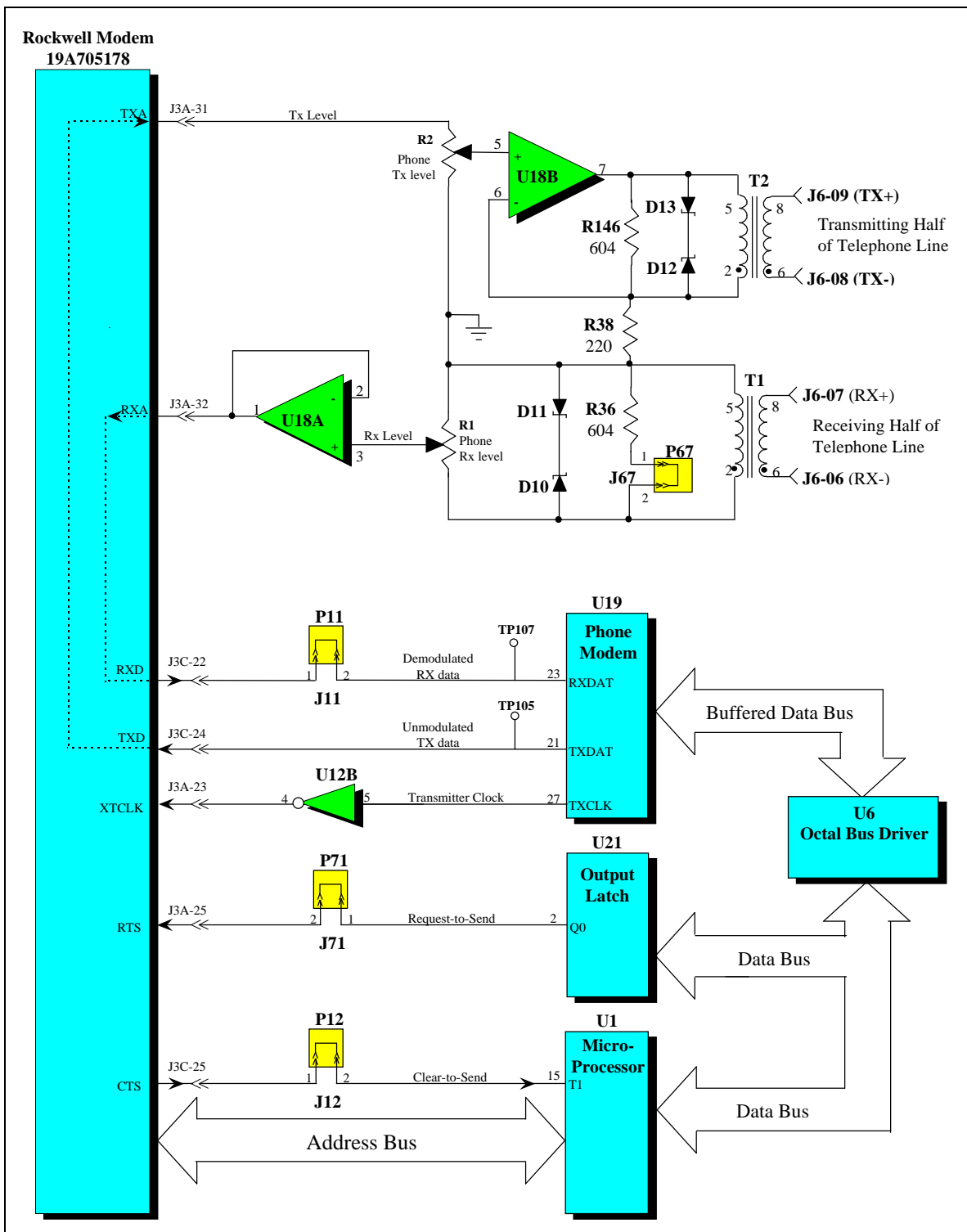

Figure 16 - Rockwell Modem and Telephone Interface

INTERFACE

STATION CONTROL INTERFACE

The following lines are available to the GETC for interface to a trunked station:

| | | |
|-------|-------------------|---|
| J6-1 | DELAY PTT | Keys the station transmitter. |
| J6-10 | DET DIS | Routes HSD and enables or disables LSD. |
| J6-11 | SYNTH DATA | Synthesizer-exciter data line (MII/Ile only). |
| J6-12 | SYNTH CLK | Synthesizer-exciter clock line (MII/Ile only). |
| J6-13 | SYNTH LCK DET | Synthesizer-exciter lock detect indicator (MII/Ile only). |
| J6-15 | SYNTH LD EN | Synthesizer-exciter load enable pulse line (MII/Ile only). |
| J6-5 | 1950 DIS | For EDACS Voting System to enable or disable the 1950 Hz Tone (squelch tone). |
| J7-13 | PA FAIL | RF power amplifier failure sensing line. |
| J7-15 | RUS OUT | Mutes or unmutes receiver audio. |
| J7-2 | VOL\SQ HI | Unfiltered receiver audio including 9600 baud High Speed Data (HSD), voice, and 150 bps Low Speed Data (HSD). |
| J7-4 | MOD OUT (EXT HSD) | Filtered HSD or Digital Voice to be transmitted. |
| J19-5 | CG HI (EXT LSD) | Low Speed Data to be transmitted along with voice. |

Synthesizer-Exciter Board Interface

The GETC logic board loads the transmit (800 MHz applications) and transmit/receive (900 MHz applications) frequency information into the station synthesizer(s) (MII/Ile only). The SYNTH DATA (J6-11), SYNTH CLK (J6-12), SYNTH LD EN (J6-15), and SYNTH LCK DET

(J6-13) signals are used. The microcomputer loads the frequency code into the synthesizer-exciter board at power-up, reset, or whenever an out-of-lock indication is obtained from the synthesizer-exciter board. The frequency code is generated by the microcomputer based upon the settings of the DIP switches or Personality Programming on the GETC logic board.

A 32-bit pattern consisting of a reference number (R), the synthesizer divide-by-N counter value (N), the synthesizer divide-by-A counter value (A), and a control bit, make up the frequency code. A single 32-bit load is made to the transmit synthesizer in 800 MHz applications. For 900 MHz applications, a 64-bit load is made (32 bits for transmit and 32 bits for receive).

The sequence of entering data into the synthesizer-exciter board is shown below. This sequence is repeated once for the transmitter and once for the receiver in 900 MHz applications.

| MSB | | | LSB |
|----------------------|----------------------|---------------------|--------------------|
| R VALUE (14 BITS) | N VALUE (10 BITS) | A VALUE (7 BITS) | CONTROL (1 BIT) |

Data Load To Synthesizer-Exciter

The clock, data, and load enable lines (for MII and MIIe only) are initialized to logic 0 at octal register U20. The data is presented on U20-16 (bit 6). After about 40 microseconds, the data is then changed to reflect the next data bit of the synthesizer load. After 32/64 bits have been clocked into the synthesizer-exciter, the load enable line changes states for a 20 millisecond period, and then returns to its previous state. Lock detect is checked at U13-2. If lock is not achieved, then the GETC attempts to reload the synthesizer-exciter board until a lock-detect is established.

The data, clock, and load enable lines are inverted as they leave the GETC and become SYNTH DATA (J6-11), SYNTH CLK (J6-12), and SYNTH LD EN (J6-15). The open-collector drivers on the GETC (U23A-2, U23B-4, and U23F-12) drive the SYNTH DATA, SYNTH CLOCK, and SYNTH LD EN lines to the synthesizer-exciter board over a bus which includes a pull-up to 7.6 volts. The SYNTH LCK DET (J6-13) line is a high (low for 900 MHz) for a positive lock-detect indication. This signal arrives at U13-3 which inverts the logic level so that the microcomputer detects a lock-detect indication by a logic 0 (1 for 900 MHz) on U13-2.

Station Control Interface

The microcomputer on the GETC logic board controls a MASTR II, IIe, or III station operation using the following control and interface lines:

The **SYNTH DATA**, **SYNTH CLK**, **SYNTH LD EN** and **SYNTH LCK DET** lines enable the microcomputer to load the frequency code to the synthesizer-exciter board (MII or IIe only).

The **DELAY PTT** line (J6-1) enables the microcomputer to turn on the station transmitter by pulling J6-1 low (logic high on U20-19). The station transmitter is turned on to 90% of full power in less than 10 milliseconds.

The **RUS OUT** line (J7-15) disables the voice audio from the transmitter (0 volts on J7-15 or logic high on U21-6). The line is grounded when High Speed Data is being transmitted, no "on channel" carrier is being received, or in the absence of received Low Speed Data. This stops the receiver from routing audio (vol/sq) to the transmitter and the Line output (using RUS_MUTE and STOP RUS_PTT). This signal is gated directly back to the station from Sys RUS Out but the GETC can control it. In MASTR II (IIe) systems, the MODULATION line is the direct FM signal from the GETC to the synthesizer-exciter board.

The **VOL/SQ HI** input line (J7-2) carries unfiltered receiver audio. This includes 9600 BAUD data, Voice and Low Speed Data. Once in the GETC, this signal is routed to the RF Data Modem U4 where it detects High Speed Data and to the Low Speed Data Decode Filter where it separates the audio from the Low Speed data. The High speed data received can be control signaling or digital voice (encrypted or not). Low speed data indicates valid channel activity.

The **LSD TX** line (J19-5) routes the Low Speed Data to the transmitter for transmission along with voice (from the receiver or the Line input). Low speed data goes into the station and through the channel guard pot and to the transmitter. The Low speed data from the GETC is transmitted to accompany voice as an indicator of valid channel activity or to pass on priority scan information.

The **PA FAIL** line (J7-13) is normally high when the RF transmitter is keyed. Low power output or too much reflected power will cause the line to go low. The line is always low when the transmitter is off.

The **RUS IN** line (J7-14) is set high (+5 Vdc) when the receiver unscelched by an "on channel" carrier. It is reporting carrier activity. It is low when the receiver is scelched.

The **REPEAT PTT** (J7-7) line is high (+5 Vdc) when the MASTR III Receiver Synthesizer is locked. When the Receiver Synthesizer is unlocked for 200 mS, the station grounds this line indicating a fault status to the GETC.

The **1950 DISABLE OUT (RPT INHIBIT)** line (J6-5) is only used in an EDACS voting system. In a voting system, when this line is high (+5 Vdc) it mutes the 1950 Hz tone (scelch tone) which is on the Line output in the absence of a clear voice, working channel call. The 1950 Hz tone will however, remain active during digital voice calls such as AEGIS or Voice Guard.

The **REM PTT** line (J7-9) is grounded when the station decodes a 2175 Hz Secur-it tone on the Line input. This signal alerts the GETC to the presence of a call from a remote source (CEC/IMC) for the duration of the 2175 hold tone

The **DELAY PTT** line (J6-1) is pulled low when the GETC wants to key the station for any reason

The **REM PTT** line (J6-16) is connected to the same line as the System Module's REM PTT switch. When the GETC grounds this line, the station executes a Rem PTT which is a higher priority than the Delayed PTT (EXT PTT). This will route audio from the Line input and will key the station if it is not already transmitting.

The **DETECT DISABLE** line (J6-10) is connected to the Modulation Control line (U25D-9) for MIII EDACS. This line is high (+5 Vdc) when High Speed Data is being routed to the transmitter (see EXT HSD) and Low Speed Data is disabled. When this line is high, the transmitter EXT HSD is set forcing the System Module to use High Speed Data regardless of the state of the EDACS system. When this line is grounded, High Speed Data is not routed and Low Speed Data is enabled.

The **EXT HSD** (J7-4) is the High Speed Data sent to the transmitter. A low MODCNTL signal (U25D-8) switches U15A (pin 12 to 14) routing filtered High Speed Data. This audio is not filtered at all in the MASTR III. The High Speed Data can be high speed control signaling or digital voice (encrypted or not).

SITE CONTROLLER INTERFACE

The GETC uses the following lines to communicate with the Site Controller:

- SITE CNTRL RX 1 (J8-1) RS-232C transmit data sent to the Master Site Controller.
- SITE CNTRL TX 1 (J8-2) RS-232C receive data from the Master Site Controller.
- SITE CNTRL RX 2 (J19-1) RS-232C transmit data sent to the backup site controller.
- SITE CNTRL TX 2 (J19-2) RS-232C receive data from the backup site controller.

The GETC communicates with the Site Controller (both the master and the backup Site Controllers) through the RS-232C communication ports J8 and J19. This data link is referred to as the Master Serial Link (MSL).

The characteristics of the MSL are as follows:

| | |
|-----------|---------------|
| Type | RS-232C |
| Baud rate | 19.2 kilobaud |
| Start bit | 1 |
| Stop bit | 1 |
| Data bits | 8 |
| Parity | None |
| Data Type | Binary |

Transmit Data

The GETC communicates to the master and backup Site Controllers through U14B, U27C, U28B and U27D. When the GETC is in the transmit data mode, the serial transmit data (TXD) from the microcomputer (U1-11) is sent to the RS-232C drivers (U14B and U28B) as shown in Figure 17. When gates U14B and U28B are enabled via U20 and U29F, the TX data output (U14B-6 and U28B-6) is routed to the Master Site Controller through J8-1. The TX data is also routed to the Backup Site Controller through J19-1.

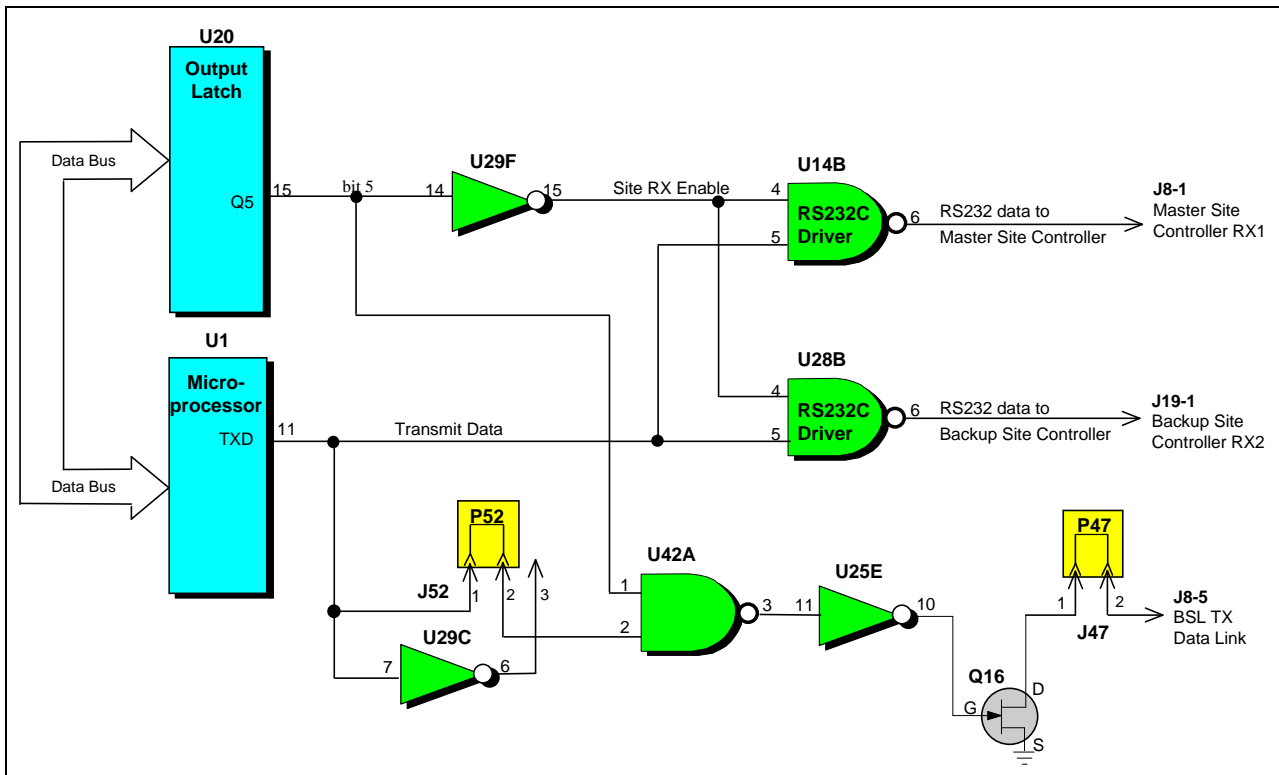

Figure 17 - GETC Data Sent To Site Controller

Receive Data

The serial receive data from the Master Site Controller, enters the logic board at J8-2 (refer to Figure 18) and goes to the RS-232C receiver (U27C-10). The serial receive data from the Backup Site Controller, enters the logic board at J19-2 and goes to the RS-232C receiver (U27D-13). The output of either Master Site Controller receiver (U27C-8) or the Backup Site Controller receiver (U27-11)is selected by the selection signal sent to the receivers. The output from the selected receiver is sent to the analog switch (U15B-1).

When the analog switch (U15B) is in fully trunked mode, the received Site Controller data output from the analog switch (U15B-15) is sent to the microprocessor receive data (RXD) input (U1-10). When the system is in Failsoft, BSL Rx Data is routed to RXD.

The decoding scheme used by the microcomputer to select which serial data will be routed to the RXD input (U1-10) is given in Table 3.

A high on U20-2 will turn on the open-collector driver (U25-12) and pull the control line (U27-9) low, disabling the output line (U27-8). A low on U20-2 enables the output at U27C. A logic high on U38-12 will turn on the open-collector transistor (Q15), and pull the control line (U27-12) low, disabling output line U27-11. A low on U38-12 enables the output of U27D.

Table 3 - Decoding Scheme

| LOGIC LEVEL | | | SIGNAL TO U15-5 | PATH SELECTED |
|-----------------|------------------|----------------------|-----------------|------------------------|
| U20-2 (11/73-1) | U38-12 (11/73-2) | U20-15 (FAILSOFT EN) | | |
| 0 | 1 | 0 | U27C-8 | Master Site Controller |
| 1 | 0 | 0 | U27D-11 | Backup Site Controller |
| X | X | 1 | U29A-2 | Backup Serial Link |

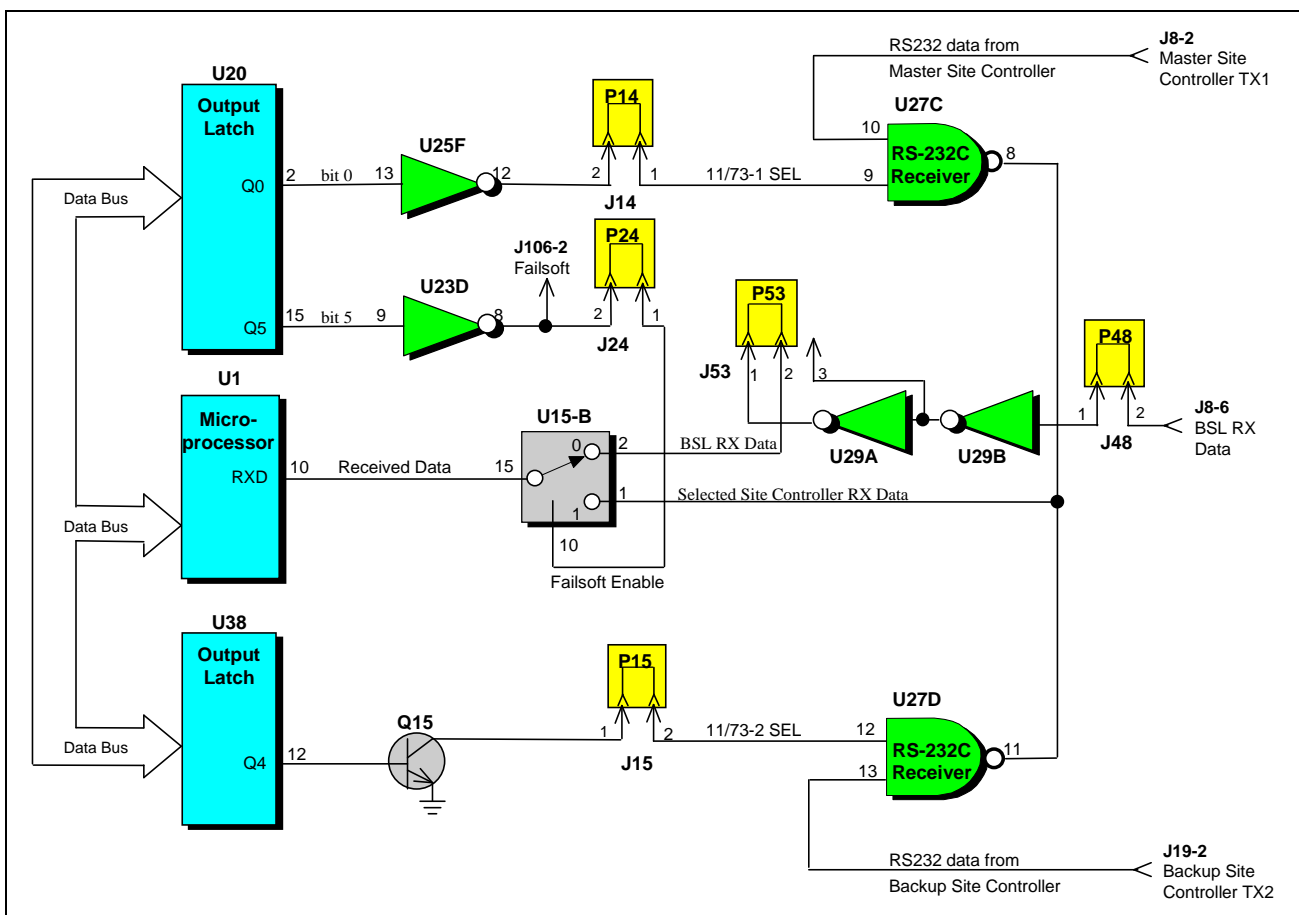

Figure 18 - Site Controller or BSL Data Sent To GETC

FAILSOFT INTERFACE

The GETC uses the following lines to communicate with a SIM or other GETC's during Failsoft operation:

| | |
|----------------------------|---|
| BACKUP TX LINK (J8-5) | Backup serial link, transmit output. |
| BACKUP RX LINK (J8-6) | Backup serial link, received input. |
| Frame Sync Link (J19-6) | Provides working channel-to-control channel data synchronization in trunked stations. |

The characteristics of the communication link are given below:

| | |
|------------|-----------------------------------|
| Level | 0 to 13.8 volts (nominal) |
| Mark/Space | 13.8 volts (mark)/0 volts (space) |
| Baud rate | 19.2 kilobaud |
| Start bit | 1 |
| Stop bit | 1 |
| Data bits | 8/9 |
| Parity | None |
| Data type | Binary |

BSL Receive Link

Receive data on the BSL RX link enters the GETC at J8-6 as shown in Figure 18. The data is buffered and inverted (if required) by U29-A and B and routed to the analog switch U15 pin 2.

When it is necessary for the GETC microcomputer U1 to enable the Failsoft mode of operation, the output at U20-15 is set high. The open-collector driver (U23D) inverts the signal and applies it to the analog switch U15B-10. This action selects the Backup Serial Link (BSL) RX link from J8-6 and routes the BSL RX data to the RXD input at U1.

The low output from U23D is also routed to J106-2. This Failsoft signal may be used by other GETC circuits to enable Failsoft operation.

BSL Transmit Link

When the GETC is transmitting TX data in the Failsoft mode, the transmit data from U1-11 (TXD) is routed to

U42A-2, as shown in Figure 17. This data may be inverted, if required, by U29C. The output from U42A is enabled when the microcomputer directs U20-15 to go low. The output is buffered by U25E and sent to the output FET Q16.

The FET is used to control the rise and fall time of signals applied to the BSL. This reduces crosstalk on the clock and data lines in the cable bundles. Resistor R148 and capacitor C110 control the fall time and R62 and C110 control the rise time of the FET drive. The FET inverts these edges

Frame Sync Line

The Frame Sync Line (FSL) is a +13.5 Vdc Bus, with periodic negative pulses (to 0 Vdc), originated by the Control Channel GETC and used by the Working Channel GETCs to synchronize messages to radios.

When the GETC operates as the Control Channel GETC, the microcomputer directs the Output latch U38 to emit sync pulses from U38-9. These pulses are sent to Q20 and Q21 which buffer the signals for input to FET Q7.

The FET controls the rise and fall time of the pulses to reduce crosstalk on the clock and data lines in the cable bundles. Resistors R176, R177 and capacitor C109 control the rise and fall time of the FET drive. The SLOT signal interfaces with the other GETCs via J19-6, Sync line.

Working Channel GETCs receive the synchronizing pulses at J19-6 and route the signals to U11B. U11B is the interface to the Input bus (bit 13). The pulses are routed to the microcomputer U1 at pin 4, where they are processed.

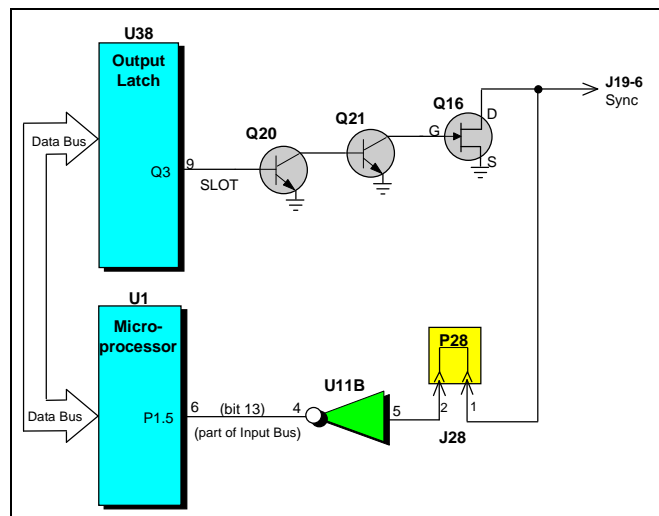

Figure 19 - Frame Sync Line Circuit

PERSONALITY PROGRAMMING

A *personality* is simply a computer file generated (created) by the user. The computer file (or personality) is downloaded into the GETC and contains data that will direct certain operating characteristics of the GETC unit. This allows each GETC to be programmed as required to meet the criteria of the application. The GETC's Personality includes system configuration information such as channel frequencies, call parameters, operating modes, and identification information.

The Personality Programming process stores data in a non-volatile region of memory. The Non-Turbo GETC's non-volatile memory consists of an EEPROM installed in the XU35 socket. For applications using the Turbo Board, Personality data is stored in the Turbo Board's battery backed memory and U35 is removed.

The Personality Programming process involves using the TQ-3357 GETC Shelf PC Programmer which creates the desired personality and transfers the Personality data to the battery backed-up RAM located on the Turbo Board.

NOTE

If installing GETC software 349A9607G4 (or later), you must use PC Programmer V4.03 (or later). Version 4.03 (or later) allows you to download Field Macros containing the new features' personality parameters.

NOTE

When using 349A9607G5 software, the Field Macro "**gtc_9505.mac**" must be installed. When using 349A9607G6 software, the Field Macro "**gtc_9506.mac**" must be installed.

TQ-3357 V4.03 (or later) also allows you to upload the GETC's Personality without changing the DIP switch settings.

NOTE

It is not necessary to recreate the personality when upgrading from Group 1 or Group 2 software to Group 4. However, to activate new features, read the existing personality and edit the personality as required.

When using PC Programmer TQ-3357 V3 (or earlier) and downloading 344A4414G3 (and earlier) software, the data from the PC files is routed to the Turbo Board microprocessors through Turbo Board programming connector J100 at the rear of the GETC Shelf.

When using PC Programmer TQ-3357 V4.03 (or later), the Turbo software is downloaded to the Turbo Board microprocessors through Turbo Board programming connector J104. Programming through J104 also allows you to load the GETC personality without changing setups. In addition, the V4.03 PC Programmer will diagnose any problems between the PC and the GETC during the downloading process and simplify the handling and archiving of the Turbo software.

Equipment Required

- IBM PC/XT/AT or compatible with Turbo software loaded in the LOAD1e directory.
- TQ-3360 programming cable.
- Male DB-25 to female DB-9 adapter or cable if the PC's serial port connector is a male DB-9 connector instead of a male DB-25 connector.

Programming a Personality Using TQ-3357 V3 (or earlier)

When using TQ-3357 Version 3 (or earlier) you must program the personality through J100.

1. Connect one end of the serial programming cable (TQ-3360) to the computer. Connect the other end of the serial cable to the GETC Shelf connector J100, see Figure 20.
2. Set the GETC DIP switches S1, S2, and S3 for the programming mode as shown in Figure 7. Set S2-8, S3-3 and S3-6 to OPEN. All other S3 positions should be CLOSED. Switches S1-1 thru S2-7 can be in any position and need not be changed. DIP switches S1-S3 are located near the front of the GETC Shelf, (see Figure 23).
3. Reset the GETC by either applying power or pressing the GETC RESET switch S4, located just below the DIP switches. Resetting the GETC, in combination with the DIP switch settings, places the GETC into the Personality Programming mode.
4. Verify that front panel LEDs L3, L4, and L5 are ON, as shown in Table 4. This indicates the GETC is ready for programming.

Table 4 - Indicators in Programming Mode Using J100

| LED Indicators | L1 | L2 | L3 | L4 | L5 | L6 | L7 |
|------------------|----|----|----|----|----|----|----|
| Programming Mode | ○ | ○ | ● | ● | ● | ○ | ○ |

Legend: ○ = OFF ● = ON * = FLASHING

5. Run the **load1e.exe** program. Follow the on screen instructions and program the Turbo Board. Additional programming instructions may be found in SRN1062 and LBI-38822.

NOTE

When using Turbo Board 344A4414 Group 2 (or later) software, re-programming the GETC Turbo Board will not alter previously stored Personality Data. When Personality Data is present, "load1e.exe" clears and performs CRC functions over the code portion of memory only.

6. Proceed with the Personality programming as described in TQ-3357 Chapter 4.
7. After saving the personality and downloading it into the GETC, perform an operational checkout of the GETC.

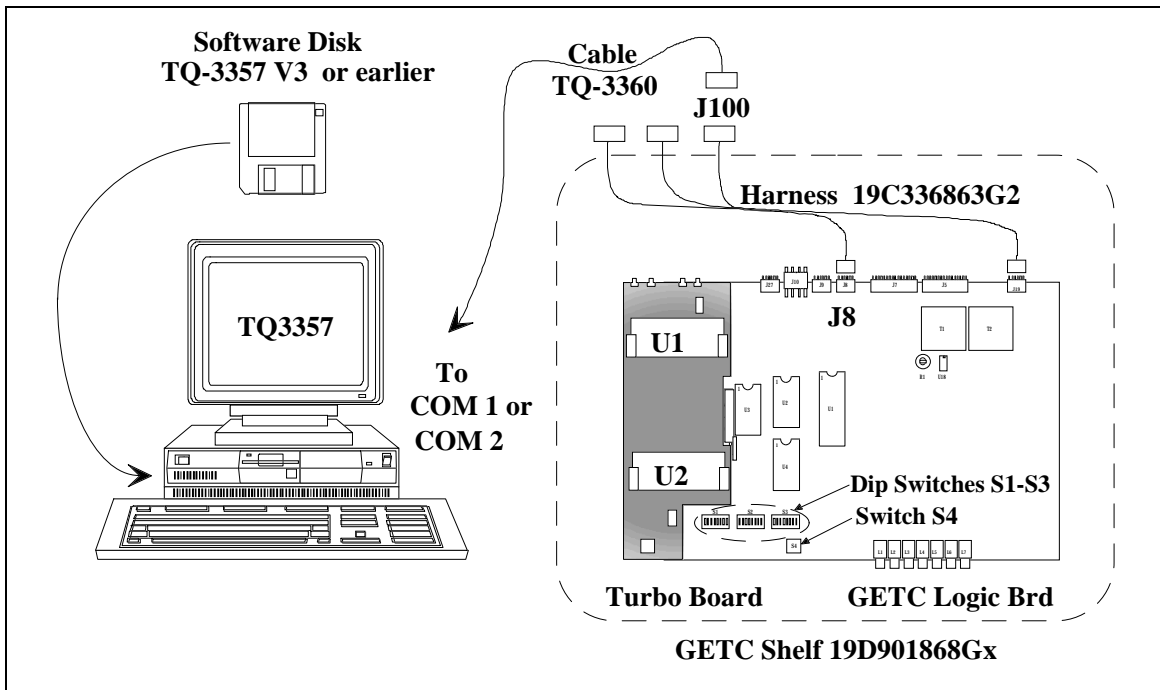

Figure 20 - System Hook-Up Using J100

**Programming a Personality Using TQ-3357
Version 4.03 (or later)**

When using TQ-3357 Version 4.03 (or later), you must program the personality through J104.

1. Connect one end of the serial programming cable (TQ-3360) to the computer. Connect the other end of the cable to the GETC Shelf connector J104. See Figure 21.
2. Move Switch S2 on the Turbo Board to the front placing the Turbo into the programming mode.
3. Verify that front panel LEDs L6 and L7 are flashing, as shown in Table 5. This indicates the GETC is ready for programming.

Table 5 - Indicators in Programming Mode Using J104

| LED Indicators | L1 | L2 | L3 | L4 | L5 | L6 | L7 |
|------------------|----|----|----|----|----|----|----|
| Programming Mode | ○ | ○ | ○ | ○ | ○ | * | * |

Legend: ○ = OFF ● = ON * = FLASHING

4. Proceed with the Personality programming as described in TQ-3357.
5. After saving the personality and downloading it into the GETC, perform an operational checkout of the GETC.

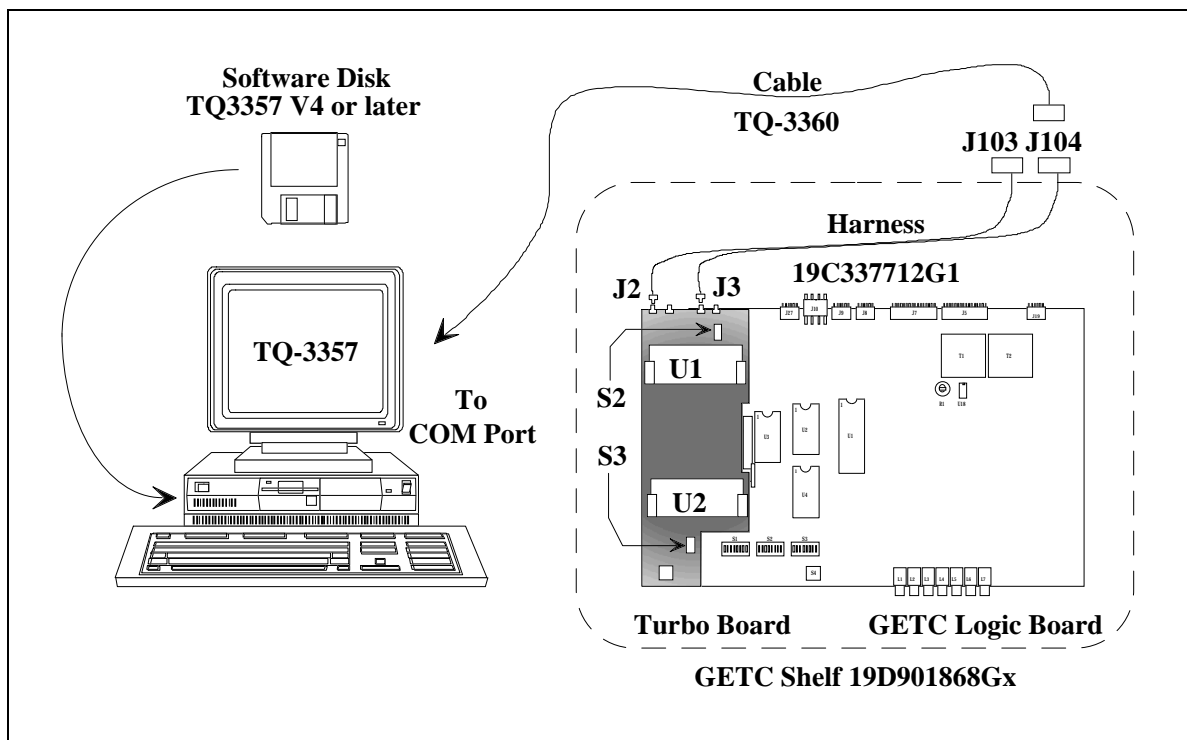

Figure 21 - System Hook-Up Using J104

MAINTENANCE

The Maintenance Section provides procedures for maintaining the GETC and for the removal and reinstallation of defective subassemblies.

SUBASSEMBLY REMOVAL AND REPLACEMENT

The following procedures provide step-by-step instructions for the removal and reinstallation of GETC subassemblies.

WARNING

Before attempting to remove any subassembly, disconnect all power from the GETC.

CAUTION



Observe precautions
for handling
**ELECTROSTATIC
SENSITIVE DEVICES**

NOTE

GETCs with the "MODIFIED FOR EUROPEAN OPERATION" label must use High Speed Filter ROA 117 2237/3 to be ETSI (European Technical Standards Institute) compliant for adjacent channel power requirements. Refer to LBI-39204 for technical details on the High Speed filter boards.

Replacing a 19D904266 or 19D902104 Logic Board

This procedure details the steps for replacing the 19D904266G1, 19D904266G4, 19D902104G1 Logic Board with the new GETC logic Board 188D6500G1 or G4.

NOTE

Ensure a 188D6500G4 board is used whenever a Speedy microprocessor is required.

Remove:

1. Remove power from the GETC. If this unit is part of an EDACS site, only turn power off to one channel at a time.
2. Disconnect the cables from the Logic Board connectors J19, J6, J7, J8, J9, J10, and J27.
3. Remove the PROM from the XU2 socket.
4. Remove the Turbo Board if installed.
5. Remove the Rockwell Modem if installed.
6. Disconnect the cable from J49 if installed.
7. Remove the optional Guarddog cable 19B803258P1, if installed.
8. Remove the 11 pan head screws securing the Logic Board to the GETC shelf plus two screws connecting the lightning ground.
9. The Logic Board may now be removed from the shelf.

Install:

1. Mount the Logic Board in the GETC shelf as shown in Assembly Diagram 19D901868G3.
2. Install the 188D6500G1 or G4 Logic Board and secure the board and Lightning Protection cables to the shelf using the 13 mounting screws.
3. Reconnect the cable to J49 if applicable.
4. Reconnect the cables to the Logic Board connectors J19, J6, J7, J8, J9, J10, and J27.
5. Install the Rockwell Modem if removed.
6. Install the Turbo Board if removed.
7. Install the PROM removed from the old board into socket XU2.
8. Install Guarddog cable RPM 113 2515, if the Guarddog option is required, and plug harness connector into J106. Ensure jumpers J16 and J24 are removed.

9. If the GETC is for use in a MASTR II station, remove the wire from J6-10 in the station harness and insulate it.
10. If the GETC is for use with a MASTR III station, remove the jumper from J26.
11. Ensure Low Speed and High Speed filters are properly installed (refer to LBI-39204 for additional filter board information).
12. Set DIP switches exactly like the old board being replaced.
13. Apply power and perform the required alignment and checkout procedures.
2. Install the 188D6500G1 or G4 Logic Board and secure the board and Lightning Protection cables to the shelf using the eleven mounting screws.
3. Reconnect the cable to J49 and J106, if applicable.
4. Reconnect the cables to the Logic Board connectors J19, J6, J7, J8, J9, J10, and J27.
5. Install the Rockwell Modem if removed.
6. Install the Turbo Board if removed.
7. Install the PROM removed from the old board into socket XU2.
8. Ensure Low Speed and High Speed filters are properly installed (refer to LBI-39204 for additional filter board information).
9. Ensure the jumpers installed on the new board match those on the old board.
10. Set DIP switches exactly like the old board being replaced.
11. Apply power and perform the required alignment and checkout procedures.

Replacing a 188D6500Gx Logic Board

This procedure details the steps for removing and reinstalling the GETC Logic Board 188D6500Gx in a 19D901868G5 or G6 GETC shelf.

Remove:

1. Remove power from the GETC. If this unit is part of an EDACS site, only turn power off to one channel at a time.
2. Disconnect the cables from the Logic Board connectors J19, J6, J7, J8, J9, J10, and J27.
3. Remove the PROM from the XU2 socket.
4. Remove the Turbo Board if installed.
5. Remove the Rockwell Modem if installed.
6. Disconnect the cable from J49 and J106 if installed.
7. Remove the eleven pan head screws securing the Logic Board to the GETC shelf (11 mounting screws plus two ground leads).
8. The Logic Board may now be removed from the shelf.

Install:

1. Mount the Logic Board in the GETC shelf as shown in Assembly Diagram 19D901868G5.

Turbo Board

This procedure details the steps for removing and installing the Turbo Board. Additional maintenance information regarding the Turbo Board assembly may be found in LBI-38822.

Remove:

1. Remove power from the GETC.
2. Disconnect the ribbon cable from the GETC Logic Board XU3 socket.
3. Disconnect the Turbo Board harness (19C337712) from the Turbo Board connectors J2 and J3.
4. Remove the Turbo Board guard (secured by three flat head screws).
5. Remove the three threaded inserts and the two pan head screws securing the board. The board may now be removed from the GETC.

Install:

1. Reinstall the Turbo Board using the following procedure. Refer to the Installation Diagram (19D438125) in LBI-38822 for parts identification.
2. Align the Turbo Board holes over the threaded spacers (orient the Turbo Board so connectors J2 and J3 are toward the rear of the GETC Shelf).
3. Secure the Turbo Board by installing two (2) pan head screws (item #6) and two (2) lock washers (item #7) through the board and into the threaded inserts located near the front of the GETC Shelf (near S1 and Y1).
4. Install three threaded inserts (item #3) through the board into the remaining spacers. These will be used to mount the guard.
5. Install the guard (item #1) using three (3) flat head screws (item #4).
6. Plug the ribbon cable from J1 on the Turbo Board into the XU3 socket on the GETC Logic Board.
7. Connect plugs P2 and P3 on the Turbo Board Harness (19C337712G1) to the Turbo Board J2 and J3 connectors, respectively.
8. Apply power and reprogram the Turbo Board and GETC Personality as required.

Rockwell Modem

This procedure details the steps for removing and reinstalling the Rockwell Modem.

Remove:

1. Remove power from the GETC.
2. Remove the Turbo Board if installed.
3. Remove the four screws securing the modem. If the GETC has a Turbo Board, remove two threaded inserts and two screws.
4. Slide the modem out of Logic Board connector J3 and lift out of GETC.

Install:

1. Insert the Rockwell Modem into J3 on the GETC Logic Board and align the mounting holes over the GETC shelf standoffs.

Isolate the modem by installing the eight (8) fiber washers (4035306P25). Insert four washers between the board and the GETC shelf mounting standoffs and place four washers on top of the modem board over the mounting holes.

NOTE

Ensure the modem is insulated from its mounting standoffs using the eight 4035306P25 washers. Four washers mount on top of the modem's printed circuit board and four washers mount on the bottom between the modem's printed circuit board and the GETC shelf standoffs.

3. Secure the modem by installing two screws through the washers and modem board into the standoffs located on the end opposite J3.
4. On the connector side (J3) of the modem, install the two (2) threaded inserts when also installing the Turbo Board or two screws to complete the modem installation.
5. Install the Turbo Board if previously removed.
6. Reapply power as required.

Power Supply, A2

This procedure details the steps for removing and reinstalling the GETC Power Supply, A2.

Remove:

1. Remove power from the GETC.
2. Unplug the Power Supply cable A2W1P1 from the GETC Logic Board connector A1J27.
3. Remove the Power Supply mounting hardware (nut and lockwasher) securing the Power Supply to the shelf (3 places).
4. Lift the Power Supply out of the GETC.

Install:

1. Mount the Power Supply in the GETC shelf as shown in Assembly Diagram 19D901868G3.
2. Secure the assembly using the three #6 nuts and lock washers.
3. Plug the Power Supply Cable A2W1P1 into the GETC Logic Board connector A1J27.
4. Reapply power and verify the regulator supplies the proper voltage as detailed in the test and alignment procedures..

5. Function Generator, HP-3312A (or equivalent), capable of producing a 0 to 10 kHz sine wave.
6. Distortion Analyzer, HP-334A (or equivalent).
7. Triplet Model 630-PL Type 5 (or equivalent) AC Volt-Ohm Meter.
8. ASCII Terminal or Personal Computer (PC) with terminal emulation program.
9. Interconnecting Cable (PC to GETC) (see Terminal Connection, step 2, for fabrication details).
10. SIMON Test PROM, 349A9607G2 (see Software Requirements for details).
11. Miscellaneous materials:
 - Jumpers 19A702104P2, 2-pin (36 ea. required). Normally supplied as part of 344A3450G9 Hardware Kit.
 - Capacitor, coupling, 10 μ F.
 - Resistor, 100 ohm, 5 watt.
 - Resistor, 680 ohm, 1/4 watt.
 - Resistor, 10K ohm, 1/4 watt (2 required).

TEST AND ALIGNMENT

The procedures presented in this section are for bench testing and aligning the GETC. When field testing the GETC, refer to the procedures contained in the GETC Installation and Configuration manual for the specific application.

GETC TESTING

The test procedures use the SIMON Test program and simulate the operation of a GETC configured for use in an EDACS Station.

Test Equipment Required

The equipment necessary for the test is listed below. This is a list of suggested equipment only. Substitutions may be made as necessary. Equivalent test equipment means you may use equipment that performs an equivalent function as required in the test. For example, the frequency counter substituted for a Fluke-1920A need only cover the required frequency range and provide the proper resolution for the test - it does not need to be equivalent to the 1920A in all aspects.

1. DC Power Supply with current limiting, HP-6286A (or equivalent), capable of producing 13.8 Vdc @ 2A.
2. Digital Multimeter, Data Technology Model 30 (or equivalent) with 20 Vdc range.
3. Oscilloscope, Tektronix-465 (or equivalent) medium bandwidth, non-storage.
4. Frequency Counter, Fluke-1920A (or equivalent) capable of measuring 12 MHz.

Terminal Connection

The GETC Test Procedure uses an ASCII terminal or a PC, running a terminal emulation program to communicate with the GETC. The following steps set up the terminal and provide instructions for connecting the terminal to the GETC.

Setup:

Configure the terminal emulator for the following communication protocol:

| | |
|---------------|-------------|
| Baud Rate | 2400 baud |
| Data Bits | 7 |
| Stop Bits | 1 |
| Parity | Odd |
| Characters | Uppercase |
| Data Transfer | Full Duplex |

GETC To Computer Connections:

Connecting the GETC to a PC requires a special cable. This cable may be fabricated according to the following

instructions or you may use the TQ-3360 cable supplied with the GETC Shelf PC Programmer.

NOTE

The PC Programmer cable, TQ-3360, can only be used if the GETC shelf has the 19C336863Gx cable installed between the GETC Logic Board and the rear panel connectors, J100 thru J103.

This fabricated cable (or the TQ-3360 cable) must be installed any time the PC (terminal) communicates with the GETC and connects between the Terminal's output port and J8 or J19 (J100 or J101) as directed by the test procedure.

Fabricate a Terminal (PC) to GETC cable if necessary. Terminal and GETC pin assignments are listed in Table 6.

Fabricate a cable with a 25-pin DB-25(M) connector (similar to AMP # 205207) on one end and a 6-pin Molex connector on the other end as shown in Figure 22.

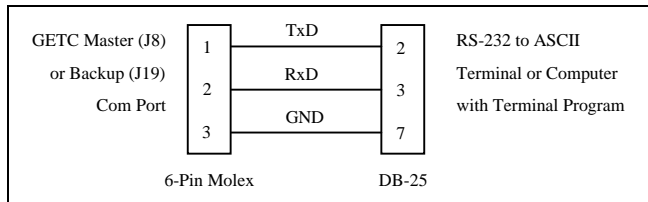

Figure 22 - Terminal-to-GETC Connection Cable

Table 6 - GETC and RS-232C Pin Assignments

| SIGNAL FROM GETC | GETC LOGIC BD PIN NUMBER (Using fabricated cable) | GETC SHELF PIN NUMBER (Using TQ-3360 PC Programmer cable) | TERMINAL EIA RS-232C D-TYPE CONNECTOR PIN NUMBER |
|------------------|---|---|--|
| TXD | J8-1 (MASTER) | J100-3 (MASTER) | PIN 3 |
| RXD | J8-2 (MASTER) | J100-2 (MASTER) | PIN 2 |
| GND | J8-3 (MASTER) | J100-1 (MASTER) | PIN 7 |
| TXD | J19-1 (BACKUP) | J101-3 (BACKUP) | PIN 3 |
| RXD | J19-2 (BACKUP) | J101-2 (BACKUP) | PIN 2 |
| GND | J19-3 (BACKUP) | J101-1 (BACKUP) | PIN 7 |

Software Requirements

The test procedures described in this manual require firmware (EPROM U2) that includes the SIMON Test code. The following PROMS contain the SIMON Test code:

| | |
|-------------------------|-----------------------------|
| 19A705595GXX | EDACS 900 MHz |
| 19A149256G16 (or later) | PST (EDACS and BASIC EDACS) |
| 349A9607G2 thru G5 | PST (EDACS and BASIC EDACS) |

If the PROM installed in the GETC does not contain SIMON, the PROM will have to be changed to one of those listed above.

Although the PROM's listed above contain the SIMON program, not all versions are capable of performing all of the tests listed. Therefore, it is recommended that only the 349A9607G2 or later versions be used.

Using SIMON

To use SIMON properly, please observe the following conventions:

- Characters that are typed from the keyboard are followed by RETURN (ENTER).
- A key press on the keyboard (such as ESC, TAB, or RETURN) is indicated in this procedure by the key name enclosed in square brackets [KEY PRESS].
- Control functions are indicated by CTRL - <CONTROL CHARACTER>, such as CTRL-Z to indicate the Z is pressed while holding down the CTRL key.
- If variable data or commands are to be entered, they will be enclosed in angle brackets <VARIABLE DATA> or <COMMAND>. Variable data depends on the particular application or test. Type the appropriate response (do not include brackets) followed by pressing the RETURN key, if required.

Table 7 - GETC Logic Board Jumper Configuration

| Jumper | Initial Test Position | FUNCTION |
|--------|-----------------------|---|
| P11* | J11 - 1&2 | Receive data from 9600 baud modem board. |
| P12* | J12 - 1&2 | Clear to send from 9600 baud modem board. |
| P13 | J13 - 1&2 | BSL Tx output to BSL Rx input. |
| P14 | J14 - 1&2 | Master site controller path selection enable. |
| P15 | J15 - 1&2 | Backup site controller path selection enable. |
| P16 | J16 - 1&2 | BSL selection enable. |
| P17 | J17 - 1&2 | LSD encode path enable. |
| P18 | J18 - 1&2 | LSD decode path enable. |
| P20 | OMIT | |
| P21 | J21 - 1&2 | Enable high-speed data acquisition rate control, HSACQ. |
| P24 | J24 - 1&2 | BSL selection (Failsoft) enable. |
| P25 | J25 - 1&2 | LSD encode path enable. |
| P26 | J26 - 1&2 | Lock-detect path enable. |
| P28 | J28 - 1&2 | Sync line input path enable. |
| P29 | J29 - 1&2 | Enable site controller RxD, J8-4. |
| P44 | J44 - 1&2 | Use for 256K or 512K EPROM. |
| P46 | J46 - 1&2 | INTO for voter concentrator. |
| P47 | J47 - 1&2 | BSL select. |
| P48 | J48 - 1&2 | BSL select. |
| P50 | J50 - 1&2 | Enable tone control for voted system |
| P51 | J51 - 1&2 | Morse code ID enable. |
| P52 | J52 - 2&3 | TxD polarity select. |
| P53 | J53 - 1&2 | RxD polarity select. |
| P54 | J54 - 1&2 | Enable MODCNTL local control. |
| P55 | OMIT | |
| P60 | J60 - 1&2 | Enables HSD path. |
| P61 | J61 - 2&3 | Use for 512K EPROM. |
| P62 | J62 - 1&2 | Selects 11.059 MHz clock Freq. for 9600 baud data, 5.5296 MHz for 4800 baud data. |
| P63 | OMIT | ON for Narrow HSD Filter, OMIT for Wide HSD Filter. |
| P67 | J67 - 1&2 | Receive telephone line termination. |
| P68 | J68 - 1&2 | Selects Local (on)/Remote (off) control of station PTT. |
| P69 | J69 - 1&2 | Enables COMB PTT IN. |
| P71 | J71 - 1&2 | Enables telephone modem RTS control. |
| P72 | J72 - 1&2 | Selects internal oscillator. |
| P73 | J73 - 2&3 | Enables NOR gate U22B for PST appl. |
| P74 | J74 - 2&3 | Selects CAS input to microprocessor. |
| P75 | OMIT | |
| | J104 - 1&2 | |
| | J104 - 3&4 | |
| | J103 - 1&2 | |

Legend: LSD = Low Speed Data BSL = Backup Serial Link
 RxD = Receive Data HSD = High Speed Data
 MSL = Main Serial Link TxD = Transmit Data
 * = For Rockwell Modem communications

Test Preparation

Before starting tests it is necessary to reconfigure the GETC for testing. The following procedure provides instructions for setting the jumpers and DIP switches. When the DIP switches are set to the Terminal settings, the GETC will automatically initiate the test mode.

CAUTION

Do Not apply power to unit under test until directed to do so.

CAUTION



Observe precautions for handling **ELECTROSTATIC SENSITIVE DEVICES**

1. Make a record of all current jumper locations and DIP switch settings.
2. Reconfigure the jumpers to the test configuration, as shown in Table 7.

The location of the jumpers may be found by using the Logic Board layout diagram in Figure 23. This figure also provides the locations of test points and adjustments referred to throughout the Test and Alignment section.

3. On the GETC Logic Board, adjust R1, R2, and R141 to mid-position.
4. Verify the Test PROM is properly installed in XU2.
5. Set the DIP switches S1-8, S2-8 and S3-1 thru S3-6 to the OPEN (logical 1) position as shown below. All other switches should be in the OFF (logical 0) position, as shown below:

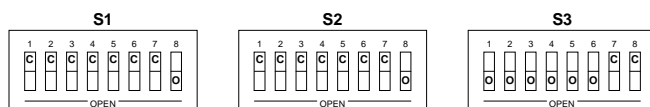

6. Move jumper P51 to J51 - 2&3.
7. Move jumper P46 to J46 - 2&3

8. Remove jumper P67.
9. Install a High Speed Filter, ROA 117 2237/1 into GETC Logic Board J
10. If using the fabricated cable, disconnect cables from J6 thru J8 and J19 and connect the Terminal (or PC) output port to the GETC Logic Board Master Serial Link (MSL) at J8.

If using the TQ-3360 cable, disconnect any external cables from J100 thru J103 and connect between the PC to and GETC shelf connector J100.

POWER SUPPLY TEST

1. Before applying power, ensure power supply is set to the correct voltage.
2. Connect power supply to GETC connector J10 (pin 1 is +13.8 V and pin 2 is ground).
3. Apply power and verify the current drawn does not exceed 0.75A (1.5A with Rockwell Modem installed). If current is excessive, turn off power and visually inspect unit and check for shorts before proceeding.
4. Measure the following voltages provided by the regulated power supply and oscillator inverter circuit. Voltages are measured with respect to ground (J10-2):

Monitor

| <u>Point</u> | <u>Voltage</u> | <u>Check if missing/incorrect</u> |
|--------------|----------------|-----------------------------------|
| TP110 | +5.0 ±0.25 V | Regulator Board (A2) |
| TP111 | +5.0 ±0.25 V | Regulator Board (A2) |
| TP108 | -12.0 ±1.2 V | -12 Volt Regulator (U39) |
| TP109 | +12.0 ±1.2 V | +12 Volt Regulator (U40) |

LOGIC BOARD TEST

These tests may be used to bench-test the GETC or test the GETC when it is installed in a station. If the tests are performed while the GETC is in a station, connectors J6 thru J8 and J19 must be disconnected.

Serial Link Test

1. Apply power to the GETC (or press RESET switch S4 if power is already applied). The terminal will display the SIMON welcome message.

If the welcome message does not appear check the following:

- Check terminal hookup to J8 (J100).
 - Be sure DIP switches (S1 - S3) are set correctly.
 - Check for +5 volts at U14-4 (SITE RX EN).
 - Check for proper operation of the reset circuitry,
 - Ensure data is being transmitted through U14 and is being received through U27.
 - When power is applied, the default serial link is the MSL. If the welcome message still does not appear, check for potential master serial link problems.
2. After the welcome message has been displayed, execute the <BCL> command (to select the backup serial link) on the terminal. Press [RETURN] and verify terminal communication to the master link is inoperative (i.e. no SIMON welcome message).
 3. Move the terminal connection from the master link J8 (J100) to the backup link J19 (J101). Press [RETURN] and verify the terminal communication on the backup link is operative. The terminal will display the SIMON welcome message.
 4. Execute the <MCL> command (master communications link) on the terminal. Press [RETURN] and verify terminal communication to the backup link is inoperative.
 5. Move the terminal connection from the backup link J19 (J101) to the master link J8 (J100). Press [RETURN] and verify the terminal communication on the master link is operative. The terminal will display the SIMON welcome message.

Modulation Setting Test (R31)

1. Execute the command <XBY B000=10>. This connects the High Speed Data Filter's output from U16 to J7-4 through U15-C.

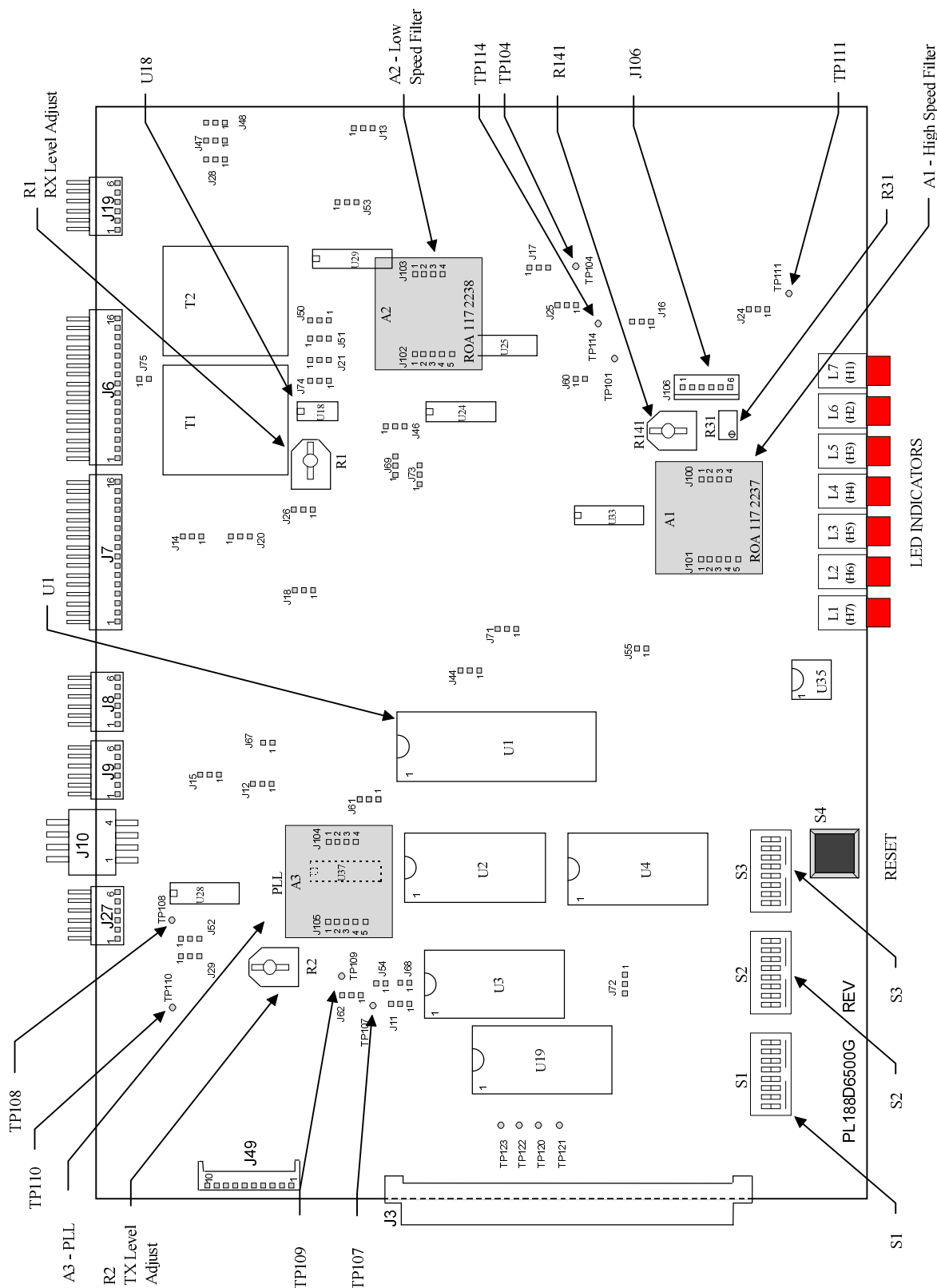

Figure 23 - Station GETC (188D6500) Jumper and Test Point Locations

- Execute the command <FNT3>. The RF modem (U4) generates a 4800 Hz signal at U4-21.
- Connect an oscilloscope to J7-4. Adjust R31 for a scope indication of $1 V_{pp} \pm 10\%$.
- Enter CTRL-Z or [ESC] to end the test.
- Momentarily ground J7-3. Verify the GETC resets and sends the SIMON welcome message to the terminal.
- Apply a ground J106-6. Verify the GETC resets and sends the SIMON welcome message to the terminal. Remove ground.

EPROM Check (U2)

- Execute the command <CHK 0-FFFF> to sum all the code bytes.
- Verify the terminal response of:

#CHECKSUM = 00

RAM Test (U3)

- Execute the command <TMX 0-1FFF> to check U3.
- Verify the terminal response of:

SIX PATTERNS CHECK OK

Microprocessor Oscillator Test (Part of U19)

- Connect the frequency counter to J62 pin 1.
- Verify the microcomputer clock frequency is $11.0592 \text{ MHz} \pm 500 \text{ Hz}$.

Reset Circuit Test (U17B)

- Lower the power supply input voltage to +6 volts.
- Slowly increase the voltage until the GETC resets and sends the SIMON welcome message to the terminal. The power supply voltage should be between +6 and +9 volts.

NOTE

Sometimes, if the voltage is raised too slowly, an improper reset may occur, resulting in a random message. This is OK.

Watchdog Timer (U4) Test

- Execute the command <WAT> to verify watchdog timer (U4) time-out.
- Verify the GETC sends the SIMON welcome message to the terminal after a two (2) second delay.

Transmit and Receive Data Test

This test verifies the operation of the 9600 baud modem (U4) and the High Speed Data (HSD) Filter. The modem generates the 9600 baud data at U4-21 (TP101) and sends it through HSD Filter A1. The data is then rerouted to the modem receive connection at U4-19 via U37C and U17A.

- Execute the command <XBY B000=10>. This causes switch U15A to route transmit data to J7-4.
- Connect a jumper between J7-4 and J7-2. This routes the transmit data through limiter U17A to the receive data port U4-19.
- Execute the command <MDS 0>. This command selects the RF modem (U4) for the Bit Error Rate (BER) command.
- Execute the command <BER DE-00=1>. This command transmits data and simultaneously checks for data being received.
- After 10 seconds, Verify the terminal response of:

ERROR COUNT = 0000

RECEIVE CHECKSUM = 00027C11

NOTE

The test will continually output data in 10 second intervals. Filtered data may be observed at J7-4

- Return the power supply input voltage to +13.8 volts.
- To end the test, press CTRL-Z or press [ESC].
- Press and release RESET switch S4. Verify the GETC resets and sends the SIMON welcome message to the terminal.
- Remove the jumper between J7-2 and J7-4.

Octal Latch (U38) Output Test

This test verifies the ability of the Octal Latch (U38) to change states when directed.

1. Move the jumper P15 to J15 pins 2 and 3.
2. Connect a 10K ohm pull-up resistor between +13.8 V (TP125) and J15-1.
3. Execute the command <XBY B800=B6>.
4. Verify the logic levels at the following points using an oscilloscope or DC Voltmeter.

| MONITOR POINT | LOGIC LEVEL LO = <0.5 V HI = >4 V, unless otherwise noted | FUNCTION |
|---------------|--|----------------|
| J15-1 | LO | 11/73-2 select |
| J19-6 | HI(> 13.0 V) | SYNC |
| U34-10 | LO | LS ACQ |
| U38-15 | HI | EEPROM power |
| U38-16 | LO | EEPROM clock |
| U38-19 | HI | not used |
| U38-2 | LO | Walsh bit 1 |
| U38-5 | HI | Walsh bit 2 |

5. Execute the command <XBY B800=49>.
6. Verify the logic levels at the following points using an oscilloscope or DC Voltmeter.

| MONITOR POINT | LOGIC LEVEL LO = <0.5 V HI = >4 V, unless otherwise noted | FUNCTION |
|---------------|--|----------------|
| J15-1 | HI (>13.0 V) | 11/73-2 select |
| J19-6 | LO | SYNC |
| U34-10 | HI (>10.0 V) | LS ACQ |
| U38-15 | LO | EEPROM power |

| | | |
|--------|----|--------------|
| U38-16 | HI | EEPROM clock |
| U38-19 | LO | not used |
| U38-2 | HI | Walsh bit 1 |
| U38-5 | LO | Walsh bit 2 |

7. Remove pull-up resistor from J15-1 and move the jumper P15 back to J15 pins 1 and 2.
8. Reset the GETC by pressing S4. The GETC should send the SIMON welcome message to the terminal.
9. After receiving the welcome message, execute the <BCL> command to select the backup communication link.
10. Move the terminal connection from J8 (J100) to J19 (J101).
11. Execute the <MCL> command to return to the master communication link.
12. The "MCL" command characters should be echoed on the screen. If no echo occurs, ensure jumper P15 is on J15 pins 1 and 2.
13. Move the terminal connection from J19 (J101) to J8 (J100).

Low Speed Handshaking Test

This test checks the operation of the Low Speed Data Encode Filter (steps 1 and 2) and the Low Speed Data Decode Filter (steps 3 thru 8).

1. Connect an oscilloscope and a voltmeter to J19-5.
2. Execute the commands for each case listed below and verify the output amplitude and symmetry. Enter CTRL-Z or [ESC] after verifying the parameters of each case.

| Case | Command | Frequency (Hz) | Amplitude (Vrms), unless otherwise noted |
|------|---------|----------------|--|
| 1 | LSH 1-1 | 10 | 0.99 to 1.10 |
| 2 | LSH 1-2 | 100 | 0.80 to 1.00 |

| | | | |
|----|---------|------|--|
| 3 | LSH 1-3 | 200 | 0.44 to 0.54 |
| 4 | LSH 1-4 | 1000 | >32 dB below value measured in case 2 |
| 5 | LSH 2-1 | 10 | 0.380 to 0.415 |
| 6 | LSH 2-2 | 100 | 0.307 to 0.370 |
| 7 | LSH 2-3 | 200 | 0.16 to 0.20 |
| 8 | LSH 2-4 | 1000 | >32 dB below value measured in case 6 |
| 9 | LSH 3-1 | 10 | 1.04 to 1.20 |
| 10 | LSH 3-2 | 100 | 0.92 to 1.18 |
| 11 | LSH 3-3 | 200 | 0.51 to 0.63 |
| 12 | LSH 3-4 | 1000 | >32 dB below value measured in case 10 |

3. Connect a jumper from J19-5 to J7-2. Disconnect the oscilloscope and voltmeter.
4. Execute the <LSH 1> command.
5. Connect an oscilloscope to J18-1 and verify a square wave with a low level value <0.5 V and a high level value >4.5 V is present.
6. Enter CTRL-Z or [ESC] to terminate the test.
7. Disconnect the oscilloscope and remove jumper from J19-5 to J7-2.

DIP Switch Test (S1, U8, S2, U9, S3, U7)

This test verifies the operation of the DIP switches and their associated buffers - S1/U8, S2/U9, and S3/U7. The switch values will be displayed in binary form and any change to the DIP switch will change the display in real time.

1. Execute the command <DSW>. The terminal will display the current DIP switch values (OPEN = 1 and CLOSED = 0) as shown below:

```

00000001    00000001    11111100
 1      8      1      8      1      8
      S1          S2          S3

```

2. Check the open and closed position of each switch. An OPEN on the DIP switch is displayed as "1", while a CLOSED is displayed as a "0".

This test continually updates the terminal display at each DIP switch setting change.

3. Return DIP switches S2-8 and S3-1 thru S3-6 to the OPEN position (shown below).

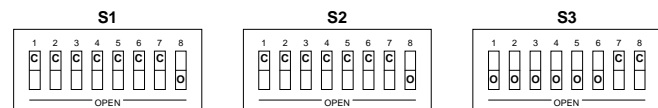

4. Enter CTRL-Z or [ESC] to end the test.

4800 Baud Divide by 2 Circuit (U41)

This test checks the divide by two function of U41 for applications requiring 4800 baud RF modem data.

1. Move jumper P62 to J62 pins 2 and 3. This routes the 5.5925 MHz clock signal output of the divide by two circuit (U41) to the RF modem U4-16.
2. Execute the command <XBY B000 = 10>. This connects the High Speed Data Filter's output (J100-3) through U15A to J7-4.
3. Execute the command <FNT3>. This causes the modem to generate a 2400 Hz signal at U4-21.
4. Connect an oscilloscope to J7-4 and verify the presence of a 2400 Hz signal.
5. Enter CTRL-Z or [ESC] to end the test.
6. Move P62 back to J62 pins 1 and 2.

Phone Modem Test (U19)

This test verifies the operation of the Phone modem (U19) by looping the transmit data to the receive data port. Serial data is transmitted out U19-21 and looped back to U19-19 as receive data.

1. Move the jumper P11 to J11 pins 2 and 3.
2. Install a jumper from J9-3 to J9-4.
3. Execute the command <MDS 1>. This selects the phone modem for the BER command.
4. Execute the command <BER DE-00=1>. This command causes the modem to transmit data and simultaneously verify the same data is being received.
5. Verify the terminal response of:

ERROR COUNT = 0000
RECEIVE CHECKSUM = 00027C11

NOTE

The test will continually output data in 1 second intervals. The data train may be observed at TP105 and TP107.

NOTE

All outputs, except as noted, are open collector and must be pulled up to +13.8 V before they will go high. This may be accomplished by connecting another 10K ohm resistor between the test probe and +13.8 volts (TP125).

6. Enter CTRL-Z or [ESC] to end the test.
7. Remove the jumper from J9-3 to J9-4.

Output Latches And Buffers Test (U20 &U21)

This test verifies the ability of the output latches and buffers (U20 and U21) to change states and checks the front panel LED's for proper indications.

1. Move jumper P14 to J14 pins 2 and 3.
2. Move jumper P24 to J24 pins 2 and 3.
3. Move jumper P25 to J25 pins 2 and 3.
4. Remove jumper P20.
5. Install a 10K ohm resistor from J7-14 to ground
6. Execute the command <XBY A800 = 52>.
7. Execute the command <XBY B000 = 42>.
8. Connect J7-6 to ground.
9. Verify the logic state at the locations listed in the next column:

| Test Point | Logic Level | Remarks |
|------------|-------------|---------------------------------------|
| J6-1 | HI | |
| J6-2 | HI | |
| J6-3 | Hi | |
| J6-4 | LO | No pull-up required |
| J6-5 | HI | |
| J6-10 | HI | |
| J6-11 | LO | No pull-up required |
| J6-12 | HI | |
| J6-13 | LO | No pull-up required LO < 0.5 V |
| J6-14 | HI | |
| J6-15 | LO | |
| J6-16 | HI | |
| J7-14 | LO | Use 10K resistor to GND LO < 0.5 V |
| J7-15 | LO | No pull-up required LO < 0.5 V |
| J7-16 | LO | |
| J9-1 | HI | No pull-up required HI > 10 V |
| J3A-25 | LO | No pull-up required LO < 0.5 V |
| J3C-13 | HI | No pull-up required HI > 3.5 V |

10. Verify front panel LED's L3, L4, and L6 are ON as shown below:

| | L1 (H7) | L2 (H6) | L3 (H5) | L4 (H4) | L5 (H3) | L6 (H2) | L7 (H1) |
|----------------|------------|------------|------------|------------|------------|------------|------------|
| LED Indicators | ○ | ○ | ● | ● | ○ | ● | ○ |

Legend: ○ = OFF ● = ON * = FLASHING

11. Execute the command <XBY B000 = B9>.

12. Execute the command <XBY A800 = AD>.

NOTE

Ensure jumper is still connected between J7-6 and Ground.

13. Verify the logic state at the locations listed below:

| Test Point | Logic Level | Remarks |
|------------|-------------|-------------------------------------|
| J6-1 | LO | |
| J6-2 | LO | |
| J6-3 | LO | |
| J6-4 | HI | No pull-up required |
| J6-5 | LO | |
| J6-10 | LO | |
| J6-11 | HI | No pull-up required |
| J6-12 | LO | |
| J6-13 | HI | No pull-up required HI > 3.5 V |
| J6-14 | LO | |
| J6-15 | HI | |
| J6-16 | LO | |
| J7-14 | HI | Use 10K resistor to GND HI > 7 V |
| J7-15 | HI | No pull-up required HI > 7 V |

| Test Point | Logic Level | Remarks |
|------------|-------------|-----------------------------------|
| J7-16 | HI | |
| J9-1 | LO | No pull-up required LO < -10 V |
| J3A-25 | HI | No pull-up required HI > 3.5 V |
| J3C-13 | LO | No pull-up required LO < 0.5 V |

14. Verify front panel LED's L1, L2, L5, and L7 are ON as shown below:

| | L1 (H7) | L2 (H6) | L3 (H5) | L4 (H4) | L5 (H3) | L6 (H2) | L7 (H1) |
|----------------|------------|------------|------------|------------|------------|------------|------------|
| LED Indicators | ● | ● | ○ | ○ | ● | ○ | ● |

Legend: ○ = OFF ● = ON * = FLASHING

15. Execute the command <XBY A800 = 00>.

NOTE

Echoes will not occur during this command.

16. Execute the command <XBY B000 = 0C>.

17. Remove the jumper between J7-6 and ground.

18. Verify the logic state at the following locations:

| Test Point | Logic Level | Remarks |
|------------|-------------|---------------------|
| J6-1 | HI | |
| J6-2 | HI | |
| J6-3 | HI | |
| J6-4 | HI | No pull-up required |
| J6-5 | HI | |
| J6-10 | HI | |
| J6-11 | HI | No pull-up required |
| J6-12 | HI | |

| Test Point | Logic Level | Remarks |
|------------|-------------|-------------------------------------|
| J6-13 | HI | No pull-up required HI > 3.5 V |
| J6-14 | HI | |
| J6-15 | HI | |
| J6-16 | HI | |
| J7-14 | HI | Use 10K resistor to GND HI > 7 V |
| J7-15 | LO | No pull-up required LO < 0.5 V |
| J7-16 | HI | |
| J9-1 | HI | No pull-up required HI > 10 V |
| J3A-25 | LO | No pull-up required LO < 0.5 V |
| J3C-13 | LO | No pull-up required LO < 0.5 V |

19. Verify all front panel LED's (L1 thru L7) are OFF.
20. Execute the command <XBY A800 = 80>.
21. Execute the command <XBY B000 = 08>.
22. Verify the logic state at the following locations:

| Test Point | Logic Level | Remarks |
|------------|-------------|---------------------|
| J6-1 | LO | |
| J6-2 | LO | |
| J6-3 | HI | |
| J6-4 | HI | No pull-up required |
| J6-5 | HI | |
| J6-10 | HI | |
| J6-11 | HI | No pull-up required |
| J6-12 | HI | |

| Test Point | Logic Level | Remarks |
|------------|-------------|-------------------------------------|
| J6-13 | HI | No pull-up required HI > 3.5 V |
| J6-14 | HI | |
| J6-15 | HI | |
| J6-16 | HI | |
| J7-14 | HI | Use 10K resistor to GND HI > 7 V |
| J7-15 | HI | No pull-up required HI > 7 V |
| J7-16 | HI | |
| J9-1 | HI | No pull-up required HI > 10 V |
| J3A-25 | LO | No pull-up required LO < 0.5 V |
| J3C-13 | LO | No pull-up required LO < 0.5 V |

23. Verify all front panel LED's (L1 thru L7) are OFF.
24. Move jumper P14 to J14 pins 1 and 2.
25. Move jumper P24 to J24 pins 1 and 2.
26. Move jumper P25 to J25 pins 1 and 2.

Input Buffer And Port Pins Test

1. Move the following jumpers:
 - P26 to J26 pins 2 and 3
 - P28 to J28 pins 2 and 3
 - P12 to J12 pins 2 and 3.
2. Connect a jumper from J9-5 to J9-1 (RTS to CTS).
3. Execute command <XBY B000=08>. This pulls-up J7-14 and applies an RS-232 HI to J9-5.
4. Ground J7-7, J7-9, J7-11, and J7-13.

5. Execute the command <POR1> and verify the terminal response of:

1010 1010

6. Execute the command <POR3> and verify the terminal response of:

XX01 XXXX (where X=DON'T CARE)

7. Remove the ground connection from J7-7, J7-9, J7-11, and J7-13.
8. Execute the command <XBY B000=01>. This pulls-up J7-14 and applies an RS-232 LO to J9-5.
9. Ground J7-6, J7-8, J7-10, J7-12 and J7-14.

10. Execute the command <POR1> and verify the terminal response of:

0101 0101

11. Execute the command <POR3> and verify the terminal response of:

XX10 XXXX (where X=DON'T CARE)

12. Move the following jumpers:

- P26 to J26 pins 1 and 2
- P28 to J28 pins 1 and 2
- P12 to J12 pins 1 and 2.

13. Remove the grounds from J7-6, J7-8, J7-10, and J7-12.

14. Remove jumper from P9-5 to P9-1.

ROCKWELL MODEM TEST

This test verifies the operation of the Rockwell modem by looping transmit data to the receive data port. If a Rockwell modem is not installed, skip this test and proceed to the next test.

1. Ensure P11 is installed on J11 pins 1 and 2.
2. Connect a jumper between J6-6 and J6-8 on the GETC Logic Board.
3. Connect a jumper between J6-7 and J6-9.
4. Connect a 680 ohm resistor between J6-8 and J6-9. This loads the transformer.

5. Adjust R1 (PH RX ADJ) and R2 (PH TX ADJ) to midrange.

6. Execute the command <TIM19>. This sets the time delay from RTS to beginning of data to 250 milliseconds.

7. Execute the command <MDS 1>. This command selects the Rockwell modem for the BER command.

8. Execute the command <BER DE-00=1>, and verify the terminal response of:

ERROR COUNT = 0000 RECEIVE CHECKSUM = 00027C11

NOTE

The first response may be in error. The test runs continually outputting data in 1 second intervals.

9. Enter CTRL-Z or [ESC] to end the test.

10. Remove the 680-ohm resistor and jumpers on J6-6 thru J6-9.

Comparator Test (U31-B)

This test checks the operation of the adjustable comparator used to sense external DC inputs on J7-10.

1. Move P74 to J74 pins 1 and 2 and ensure R141 is adjusted to its midrange position.
2. Apply a logic +5 Vdc (TP111) to J7-10.
3. Execute the command <POR1> and verify the terminal response of:

XXX1 XXXX (where X=DON'T CARE)

4. Remove the 5 volts and connect J7-10 to ground.

5. Execute the command <POR1> and verify the terminal response of:

XXX0 XXXX (where X=DON'T CARE)

6. Move P74 to J74 pins 2 and 3.

7. Remove the ground connection from J7-10

Transmit Clock Test

1. Connect an oscilloscope and frequency counter to J3C-16 and observe a 9600 Hz square wave.
2. The square wave frequency should be 9600 Hz \pm 1 Hz (104.17 μ s period).
3. Verify the square wave's amplitude is greater than 4.2 V_{pp}.

FSL & BSL Drive Test

1. Connect a 100 ohm 5 watt resistor between the +13.8 Vdc (TP125) and J19-6.
2. Execute the command <XBY B800 = 08>.
3. Measure the voltage at J19-6, voltage must be less than 0.8 Vdc.
4. Execute the command <XBY B800 = 00> and remove the 100 ohm resistor.
5. Connect a 10K ohm resistor between J19-6 and ground (TP124).
6. Measure the voltage at J19-6, voltage must be greater than 11.0 Vdc.
7. Remove the 10K resistor.
8. Remove P24 and connect a 100 ohm 5 watt resistor between the +13.8 Vdc (TP125) and J8-5.
9. Execute the command <XBY A800 = 20>.
10. Execute the command <POR3 = ED> (echoes will not occur).
11. Measure the voltage at J8-5, voltage must be less than 0.8 Vdc.

12. Reset the GETC by either depressing S4 or momentarily grounding J7-3.
13. Remove the 100 ohm resistor and connect a 10K ohm resistor from ground (TP124) to J8-5.
14. Measure the voltage at J8-5, voltage must be greater than 11.0 Vdc.
15. Remove the 10 K resistor and install P24 on J24 pins 1 and 2.

Guarddog Test

This test verifies the Guarddog (remote reset) circuitry on the Logic Board.

1. Execute the command <XBY A800 = 20>.
2. Connect a jumper from J106-3 to J106-4.
3. Connect a 10K ohm pull-up resistor between 5 Vdc (TP111) and J106-2.
4. Remove jumpers P16 and P24 if present.
5. Observe the voltage on J106-2. Voltage must be less than 0.8 Vdc
6. Connect a ground to J106-2.
7. Reset the GETC.
8. Observe the voltage on J16-2. Voltage must be greater than 11.5 Vdc
9. Replace jumpers P16 on J16 pins 1 and 2 and P24 on J24 pins 1 and 2 if removed in step 4. Remove pull-up resistor installed in step 3.

TROUBLESHOOTING

The hardware used in the GETC is extremely reliable, making component failure the unlikely cause of most problems. The most common causes of problems are programming errors and interface connections.

ON SITE TROUBLESHOOTING

Use the following guidelines when troubleshooting a GETC on site:

1. Verify the condition of front panel LEDs. In some applications these indicators will actually indicate the cause of the failure or identify communication problems.
2. If available, use the activity logging feature to isolate activity which might be contributing to the problem.
3. Verify that all cables are properly connected and secure. Refer to the applicable configuration manual.

4. Verify the GETC's personality is properly programmed for the specific application. Refer to the configuration manual and the software release notes.
5. Verify the Turbo Board is properly configured if applicable.
6. If you suspect that the GETC has failed, replace the GETC with a known good unit properly configured for this application.
7. If the replacement GETC resolves the problem, bench check the defective unit using the Test and Alignment procedures contained in this manual.

IN CASE OF DIFFICULTY

If you are unable to resolve a problem to your satisfaction, then contact the Ericsson Technical Assistance Center (TAC) at 1-800-528-7711 (outside USA, 804-528-7711).

MODIFICATIONS

As a result of the diversification of the GETC, the maintenance technician is apt to encounter a number of different variations of this unit.

The modifications presented in this section are some of the more common modifications which may be encountered in a basic GETC. However, it will be necessary to refer to the configuration manual for the specific GETC application in order to identify any unique modifications and the required interface cabling and harnesses.

GUARDOG AUTOMATIC RESET

The EDACS Guardog™ option allows users to automatically or remotely reset an EDACS repeater via the Station GETC. Automatic resetting is accomplished when the Reset Unit senses the GETC has enabled Failsoft. When Failsoft is enabled, the Reset Unit initiates an automatic reset cycle to reset to station. Refer to the Failsoft Interface section and LBI-39004 for circuit analysis.

Remote resetting is accomplished when the Reset Unit decodes individual reset commands from a DTMF telephone connected to the site. Refer to the Reset Circuitry section and LBI-39004 for the circuit analysis.

Installation

GETC's with this option can be identified by the Turbo GETC Bracket (19C337711P1) with four connectors. Two of the connectors, J103 and J104 (DB-9F) are for the Turbo option and J3 and J4 (square white connectors) are for the Automatic Reset option.

The installation modifies the GETC by installing the Automatic Reset cable RPM 113 2515.

1. The two 4-pin connector blocks are mounted in the GETC Turbo bracket at J3 and J4.
2. Jumpers from J16 and J24 are removed.
3. The cable's 6-pin plug plugs into the GETC Logic board connector J106.

Refer to LBI-39004 for complete details on installing the Guarddog system and operation of the Reset Unit.

MICROPROCESSOR RYT 121 6060.

GETCs using the 349A9607G4 software (or later) require a faster microprocessor. This additional speed is provided by the Dallas *SpeedIt* μP 80C320 microprocessor

(RYT 121 6060/A). The processor is factory installed in GETC 19D901868G6.

This procedure should only be used if it is necessary to upgrade an older GETC which was using the 19A705557P1 microprocessor.

Installation

Use the following procedure when installing the replacement microprocessor in U1.

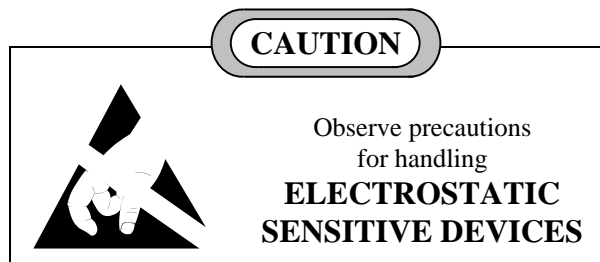

1. Remove power from GETC.
2. Slide GETC shelf into service position.
3. Verify CMOS Modems U4 and U19 are EGE part number ROP 101 868/3 (manufactured by Texas Instruments). The faster microprocessor may not work properly with earlier versions of the modem.
4. Remove U1 (19A705557P1).
5. Install the new faster microprocessor (RYT 121 6060/A) into the XU1 socket. This processor is similar to the Dallas *SpeedIt* μP (80C320).
6. Checkout GETC performance according to the test procedure in LBI-38894.

LIGHTNING PROTECTION GROUNDING

Maximum lightning protection is achieved when the GETC Lightning-Protection Grounding Kit (344A4500) is installed. This kit is normally installed at the factory for all GETC applications.

The following procedure summarizes the installation process:

1. Two wires (black 16 AWG hookup wire, 2-feet long) are prepared as follows:
 - a. The wires are stripped and tinned 1/2-inch on one end and 1-inch on the other end.

b. A solderless terminal (19B209260P1), bent approximately 30 degrees so it will clear the board mounting screw, is attached to the end stripped back 1/2-inch on each wire as shown in Figure 24.

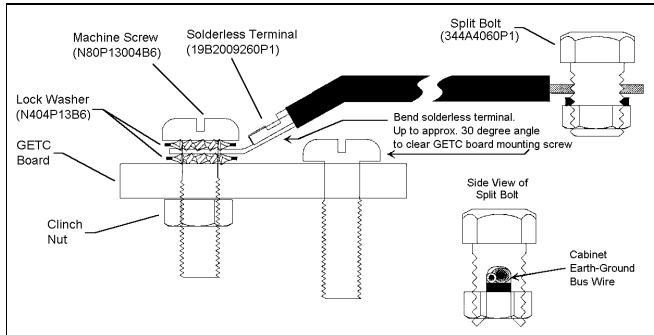

Figure 24 - Lightning-Protection Kit Installation Detail

2. The solderless terminal end of the wires is then attached to the GETC Logic Board using the lock washers and machine screw as shown in Figure 24. A clinch nut is already mounted to the solder side of the board.
3. The wires are then routed out of the shelf as shown in Figure 25.

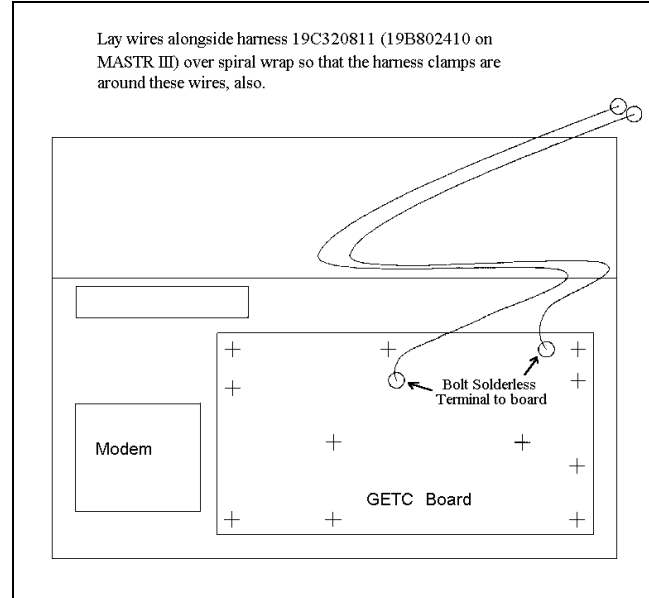

Figure 25 - Lightning-Protection Kit Cabinet Installation

4. When the shelf is installed in the rack, use the split bolts to attach the wires' end stripped 1-inch to the cabinet earth-ground bus wire (part of the Cabinet Grounding Strap Kit 344A4730) as shown in the split bolt side view in Figure 24.

NOTE

In order to be effective, the Cabinet Grounding Strap must be strapped to the building and/or earth ground.

8-BIT MICROPROCESSOR - U1
19A705557P1 (P80C32)

FUNCTION DIAGRAM

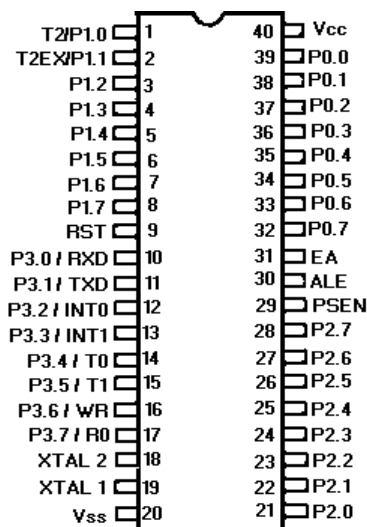

FUNCTION DIAGRAM

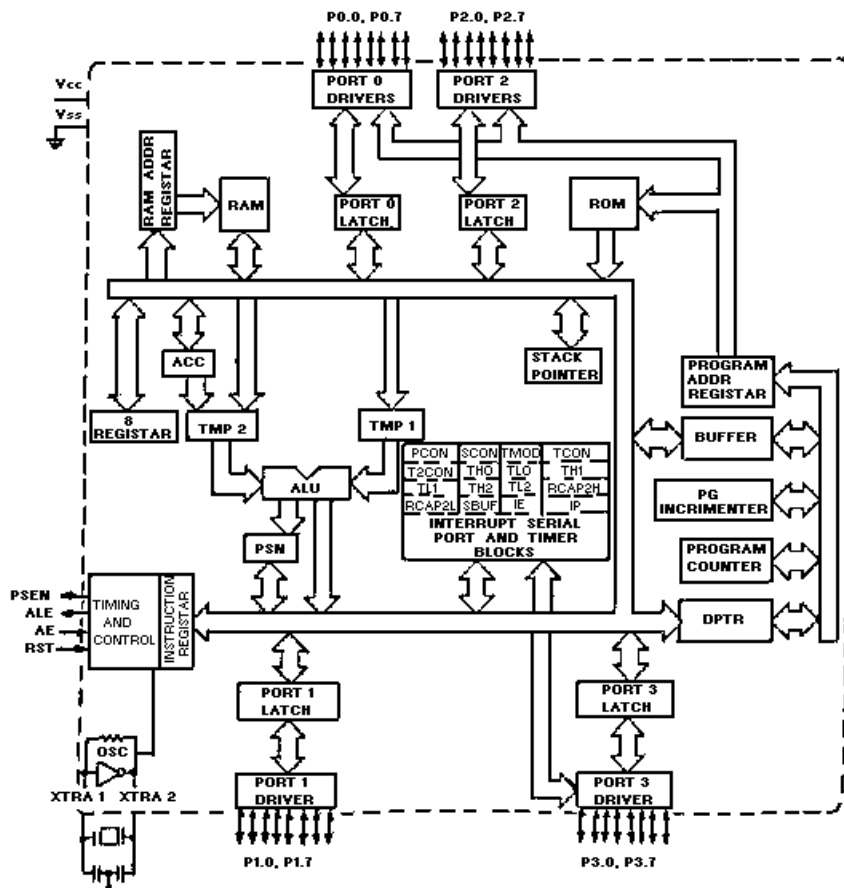

MICROCOMPUTER ABBREVIATIONS

PORT: PART OF THE I/O SECTION OF A PROCESSOR
 P12 }
 P1.2 } MEANS PORT 1 BIT 2
 P1-2 }
 RST: RESET PROGRAM COUNTER TO 0
 RXD: RECEIVE DATA (SERIAL)
 TXD: TRANSMIT DATA (SERIAL)
 INT0: INTERRUPT 0
 T0: INTERRUPT INPUT USUALLY USED FOR TESTING
 WR: WRITE DATA TO EXTERNAL MEMORY
 RD: READ DATA FROM AN EXTERNAL MEMORY
 XTAL: CRYSTAL INPUT TO INTERNAL OSCILLATOR
 EA: ENABLE
 ALE: ADDRESS LATCH ENABLE OUTPUT USED FOR LATCHING

PROG: PROGRAMMABLE I/O STROBE
 PSEN: PROGRAM STORE ENABLE USUALLY USED WITH EXTERNAL MEMORY
 SS: SINGLE STEP USED FOR SINGLE STEPPING A PROGRAM
 DB: DATA BUS
 Vss: CIRCUIT GROUND POTENTIAL
 Vcc: + ? VOLTS POWER SUPPLY DURING OPERATION PROGRAMMING, & VERIFICATION
 VPD: STANDBY POWER TO INTERNAL RAM
 CS: CHIP SELECT-ENABLES INPUTS & OUTPUTS
 CE: CHIP ENABLE-ENABLES THE CHIP
 OE: OUTPUT ENABLE-ENABLES THE OUTPUTS
 VPP: SUPPLY VOLTAGE DURING PROGRAMMING
 PGM: PROGRAMMING-USED FOR PROGRAMMING

U1 - 8-BIT MICROPROCESSOR
RYT 121 6060/A (80C320)

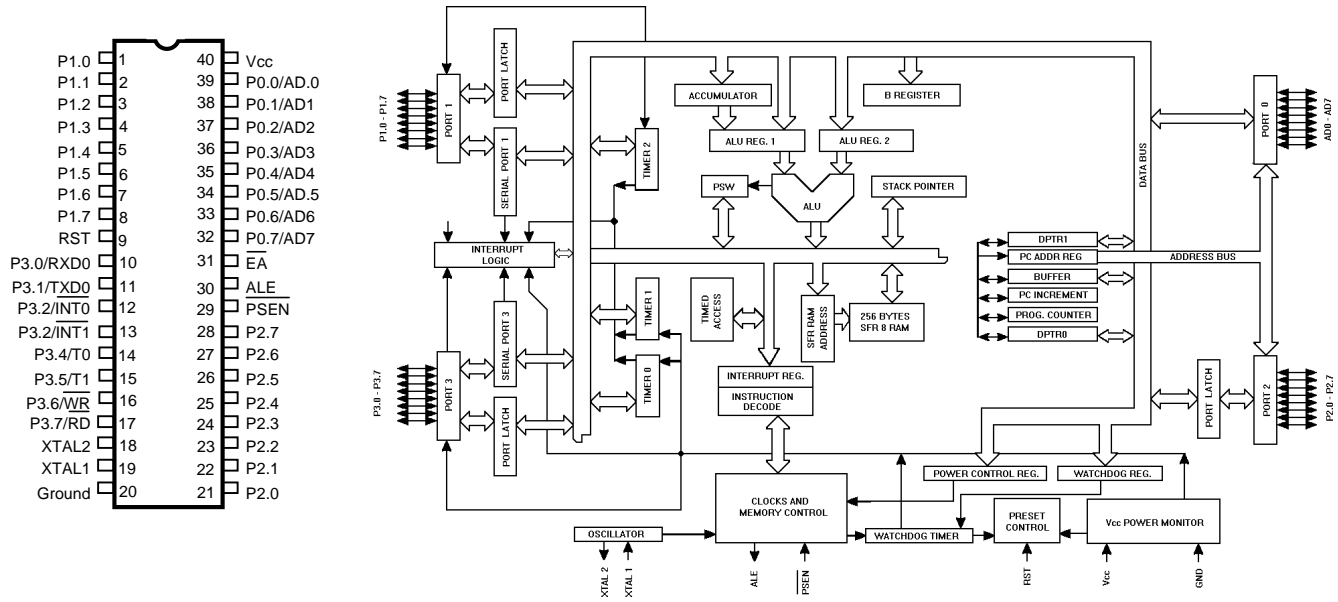

U3 - DIGITAL 8K X8 RAM
19A705558P12

PIN ASSIGNMENT

| | | | |
|-----|----|----|-----|
| NC | 1 | 28 | Vcc |
| A12 | 2 | 27 | W |
| A7 | 3 | 26 | E2 |
| A6 | 4 | 25 | A8 |
| A5 | 5 | 24 | A9 |
| A4 | 6 | 23 | A11 |
| A3 | 7 | 22 | E1 |
| A2 | 8 | 21 | A10 |
| A1 | 9 | 20 | E1 |
| A0 | 10 | 19 | DQ7 |
| DQ0 | 11 | 18 | DQ6 |
| DQ1 | 12 | 17 | DQ5 |
| DQ2 | 13 | 16 | DQ4 |
| VSS | 14 | 15 | DQ3 |

| PIN NAMES | |
|-----------|-------------------|
| A0-A12 | Address |
| W | Write Enable |
| E1, E2 | Chip Enable |
| G | Output Enable |
| DQ0-DQ7 | Data Input/Output |
| VCC | +5 V Power Supply |
| VSS | Ground |
| NC | No Connection |

BLOCK DIAGRAM

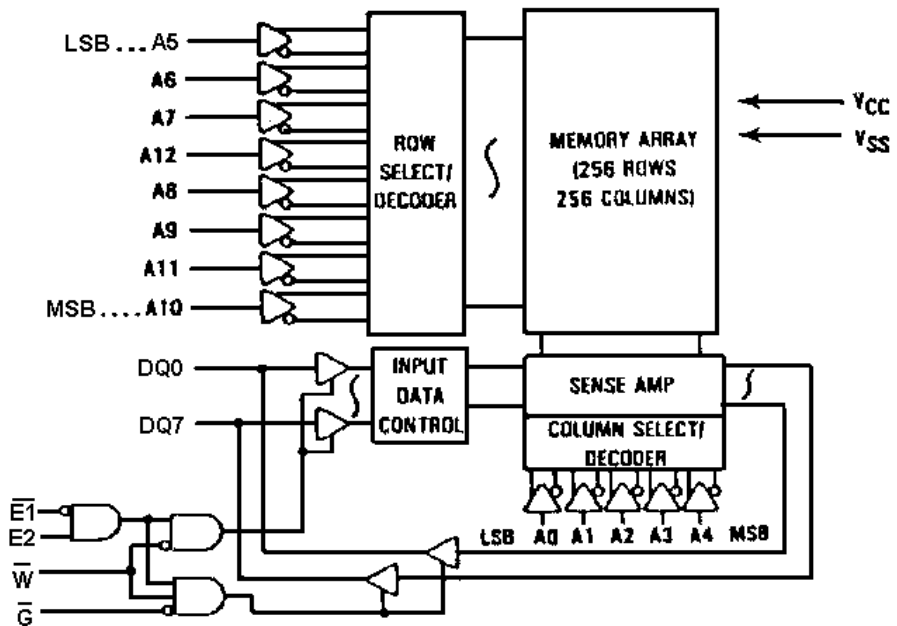

MODEM - U4/U19
ROP 101 688/3

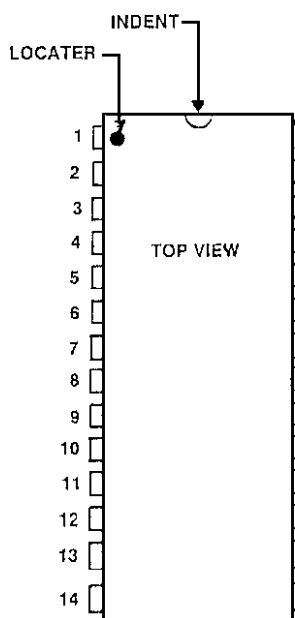

| PIN NAME | 28 PACK PIN | DESCRIPTION |
|-----------|-------------|--|
| RE | 1 | READ ENABLE (ACTIVE LOW) |
| EN | 2 | CHIP ENABLE (ACTIVE LOW) |
| RESOUT | 3 | RESET OUTPUT (ACTIVE HIGH) |
| AD0 | 4 | BI-DIRECTIONAL ADDRESS/DATA BUS |
| AD1 | 5 | BI-DIRECTIONAL ADDRESS/DATA BUS |
| AD2 | 6 | BI-DIRECTIONAL ADDRESS/DATA BUS |
| AD3 | 7 | BI-DIRECTIONAL ADDRESS/DATA BUS |
| AD4 | 8 | BI-DIRECTIONAL ADDRESS/DATA BUS |
| AD5 | 9 | BI-DIRECTIONAL ADDRESS/DATA BUS |
| AD6 | 10 | BI-DIRECTIONAL ADDRESS/DATA BUS |
| AD7 | 11 | BI-DIRECTIONAL ADDRESS/DATA BUS |
| ALE | 12 | ADDRESS LATCH ENABLE (ACTIVE HIGH) |
| VSS | 13 | GROUND |
| CLK1 | 14 | BUFFERED OSCILLATOR OUTPUT |
| VDD | 15 | POWER SUPPLY |
| XTAL1 | 16 | OSCILLATOR INPUT |
| XTAL2 | 17 | OSCILLATOR OUTPUT |
| CLK2 | 18 | 640 KHZ OUTPUT |
| DATAIN | 19 | RECEIVED DATA INPUT |
| SAT/G1 | 20 | RECEIVED SAT INPUT/G1 EN. HC138 (ACT. HI) |
| TXDAT | 21 | TRANSMIT DATA OUTPUT |
| RCVCLK/Q2 | 22 | RECOVERED CLOCK OUTPUT/Q2 OUTPUT FOR HC138 |
| RCVDAT/Q0 | 23 | RECOVERED DATA OUTPUT/Q0 OUTPUT FOR HC138 |
| INT | 24 | INTERRUPT REQUEST (ACTIVE LOW O.D.) |
| RESIN | 25 | RESET INPUT (ACTIVE HIGH) |
| CS | 26 | CHIP SELECT (ACTIVE LOW) |
| CLK3/4 | 27 | TRANSMIT CLOCK OUTPUT/CLK1/6 OUTPUT |
| WR | 28 | WRITE ENABLE (ACTIVE LOW) |

OCTAL DATA LATCH - U5
19A703471P2 (74HC373)

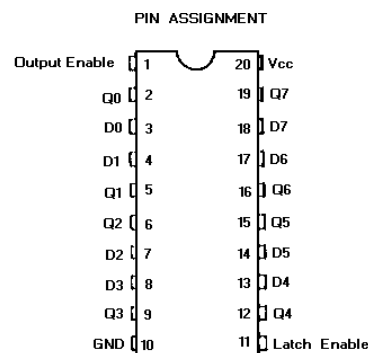
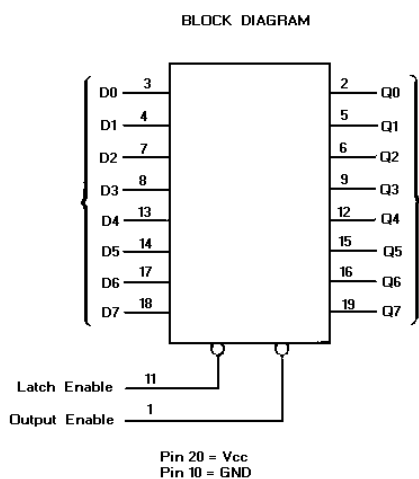

FUNCTION TABLE

| Output Enable | Latch Enable | D | Output |
|---------------|--------------|---|-----------|
| L | H | H | H |
| L | H | L | L |
| L | L | X | no change |
| H | X | X | Z |

X = don't care
Z = high impedance

**U6 - OCTAL TRI-STATE TRANSCEIVER
19A703471P8 (74HC245)**

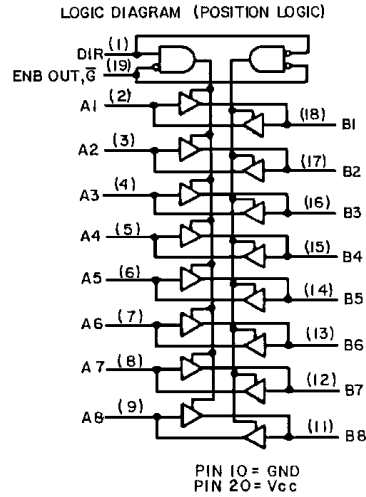
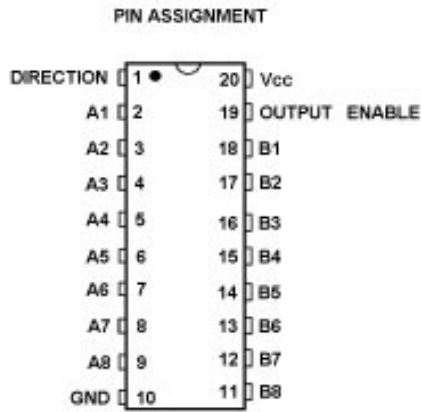

FUNCTION TABLE

| CONTROL INPUTS | | OPERATION |
|----------------|-----------|---------------------------------------|
| OUTPUT ENABLE | DIRECTION | |
| L | L | DATA TRANSMITTED FROM BUS B TO BUS A |
| L | H | DATA TRANSMITTED FROM BUS A TO BUS B |
| H | X | BUSES ISOLATOR (HIGH IMPEDANCE STATE) |

X= DON'T CARE

**U7/U8/U9 - OCTAL TRI-STATE BUFFER
19A703471P1 (74HC244)**

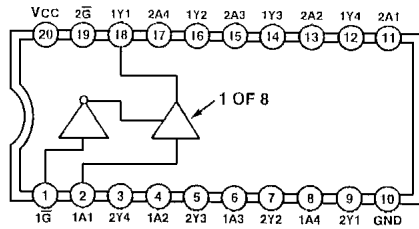

| $\bar{1}G$ | 1A | 1Y | $\bar{2}G$ | 2A | 2Y |
|------------|----|----|------------|----|----|
| 0 | 0 | 0 | 0 | 0 | 0 |
| 0 | 1 | 1 | 0 | 1 | 1 |
| 1 | 0 | Z | 1 | 0 | Z |
| 1 | 1 | Z | 1 | 1 | Z |

Z = HIGH IMPEDANCE

**U10 - DUAL 2-TO-1 DECODER/DEMULTIPLEXER
19A700037P363 (74LS155)**

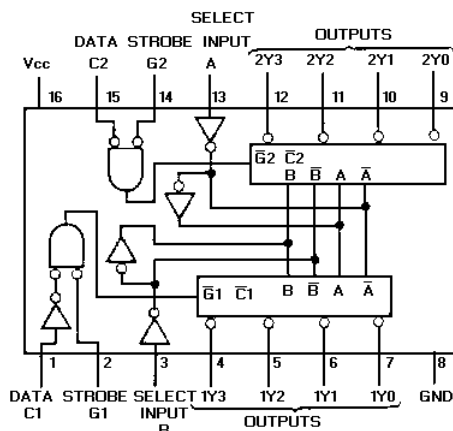

2-Line-to-4-Line Decoder
or 1-Line-to-4-Line Demultiplexer

| Inputs | | | | Outputs | | | |
|--------|--------|------|----|---------|-----|-----|-----|
| Select | Strobe | Data | | 1Y0 | 1Y1 | 1Y2 | 1Y3 |
| B | A | G1 | C1 | | | | |
| X | X | H | X | H | H | H | H |
| L | L | L | H | L | H | H | H |
| L | H | L | H | H | L | H | H |
| H | L | L | H | H | H | L | H |
| H | H | L | H | H | H | H | L |
| X | X | X | L | H | H | H | H |

| Inputs | | | | Outputs | | | |
|--------|--------|------|----|---------|-----|-----|-----|
| Select | Strobe | Data | | 2Y0 | 2Y1 | 2Y2 | 2Y3 |
| B | A | G2 | C2 | | | | |
| X | X | H | X | H | H | H | H |
| L | L | L | L | L | H | H | H |
| L | H | L | L | H | L | H | H |
| H | L | L | L | H | H | L | H |
| H | H | L | L | H | H | H | L |
| X | X | X | H | H | H | H | H |

**U11/U12/U13/U29
HEX INVERTING BUFFER/CONVERTER
19A700176P1 (4049UB)**

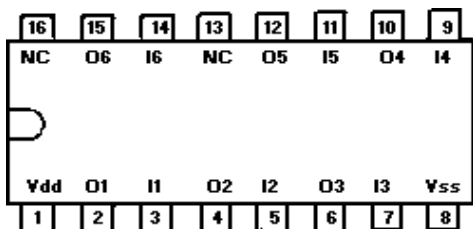

**U15/U34
CMOS TRIPLE 2 CHANNEL
MULTIPLEXER
19A700029P38 (4053)**

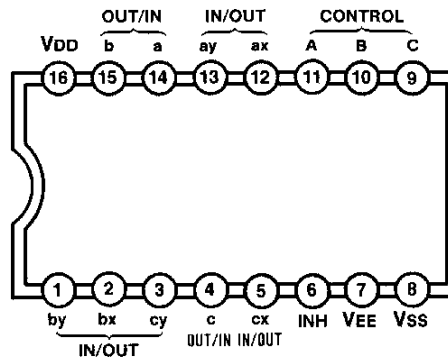

| INPUT | | | | "ON" CHANNELS | | |
|-------|---|---|---|---------------|------|------|
| INH | C | B | A | c | b | a |
| 1 | x | x | x | NONE | NONE | NONE |
| 0 | 0 | 0 | 0 | CX | BX | AX |
| 0 | 0 | 0 | 1 | CX | BX | AY |
| 0 | 0 | 1 | 0 | CX | BY | AX |
| 0 | 0 | 1 | 1 | CX | BY | AY |
| 0 | 1 | 0 | 0 | CY | BX | AX |
| 0 | 1 | 0 | 1 | CY | BX | AY |
| 0 | 1 | 1 | 0 | CY | BY | AX |
| 0 | 1 | 1 | 1 | CY | BY | AY |

**U30/U32/U33/U37
QUAD OPERATIONAL AMPLIFIER
19A704883P1 (MC3303P)**

PIN CONNECTIONS

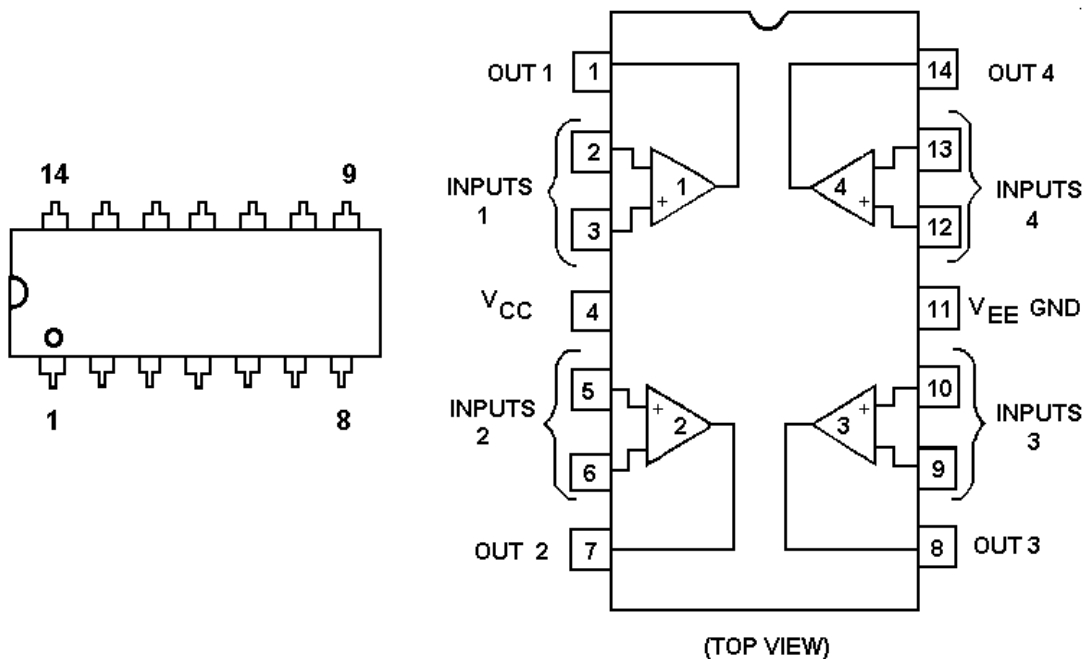

U17/U31
DUAL VOLTAGE COMPARATOR
19A134764P2 (LM393N)

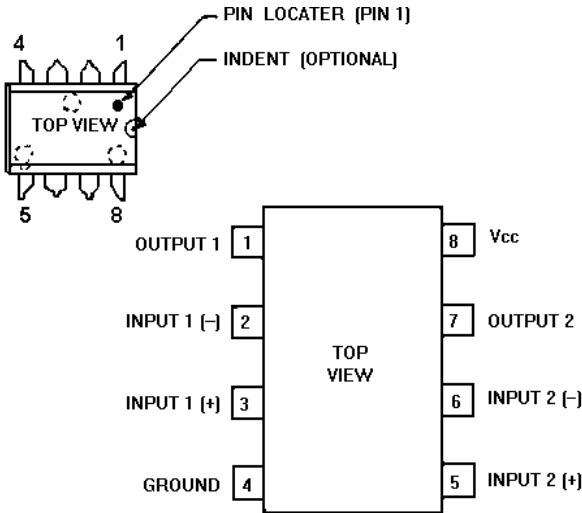

U18
DUAL OPERATIONAL AMPLIFIER
19A700086P4 (4558)

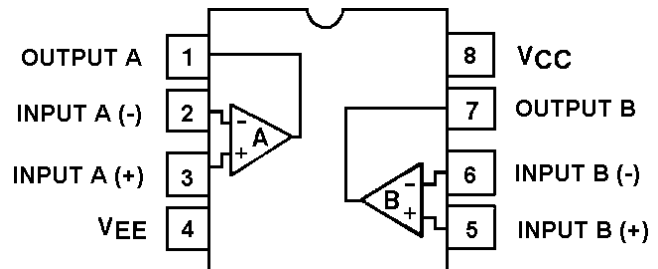

U20/U21/U38
CMOS OCTAL DATA FLIP-FLOP
19A704380P11 (74HC273)

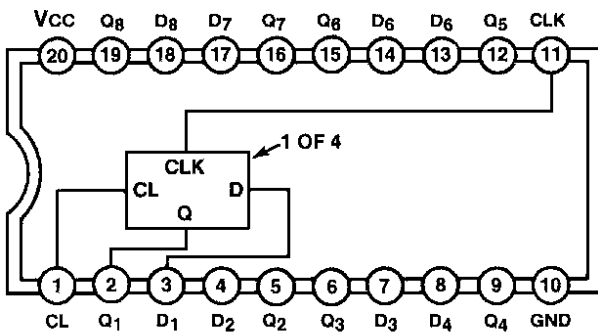

| INPUTS | | OUTPUTS | |
|--------|-------|---------|----------------|
| CLEAR | CLOCK | D | Q |
| ∅ | X | X | ∅ |
| 1 | | 1 | 1 |
| 1 | | ∅ | ∅ |
| 1 | ∅ | X | Q ₀ |

X = DON'T CARE Q₀ = Q BEFORE

U22
CMOS QUAD 2-INPUT NOR GATE
19A703483P1 (74HC02)

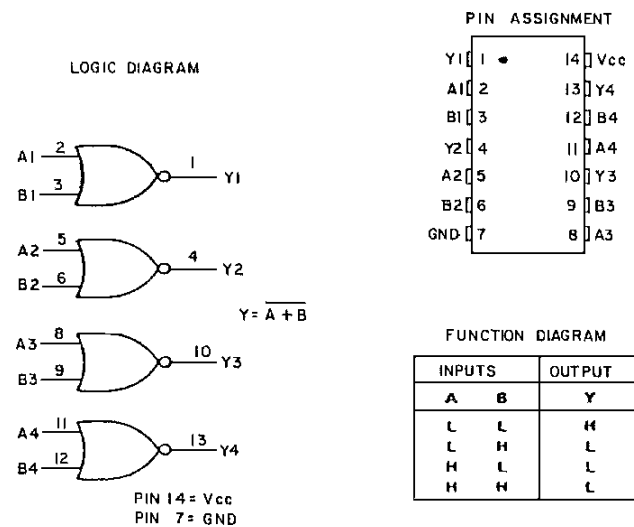

U23/U24/U25/U26
HEX OPEN COLLECTOR INVERTER
19A116180P75 (7406)

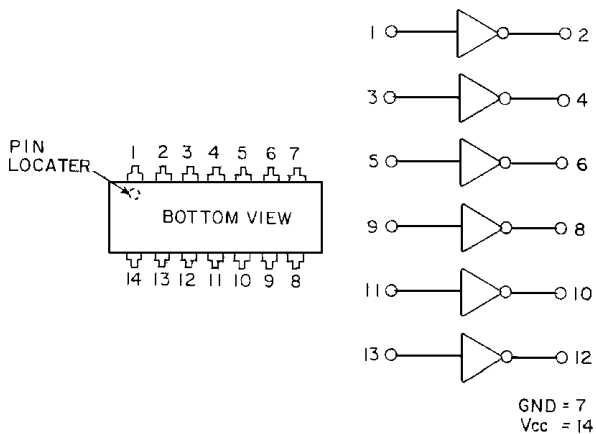

U27
QUAD LINE RECEIVER
19A116704P2 (1489)

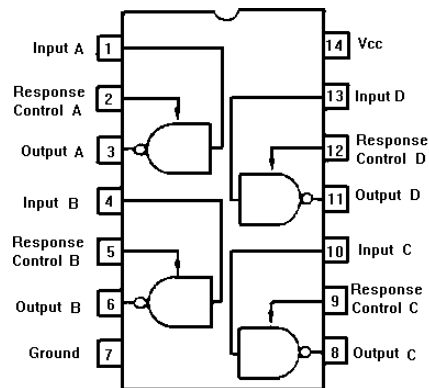

U14/U28
QUAD LINE DRIVER
19A116704P1 (1488)

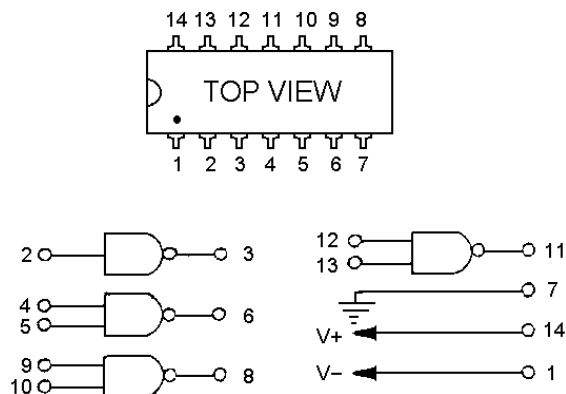

U42
QUAD 2-INPUT NAND GATE
19A700029P7 (4011B)

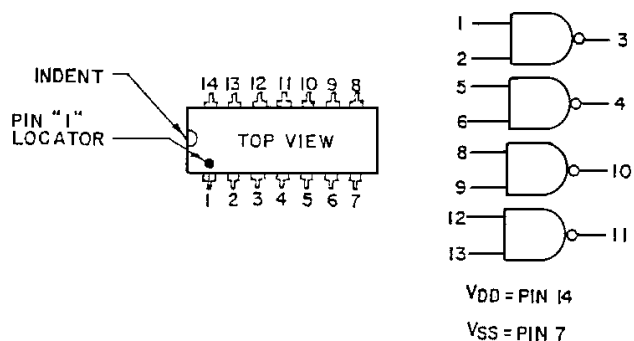

U39
-12 VOLT REGULATOR
19A134718P2 (A7912U)

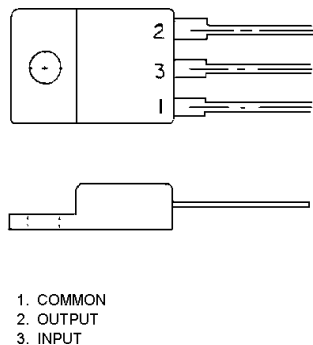

U40
12 VOLT REGULATOR
19A134717P2 (MC7812CT)

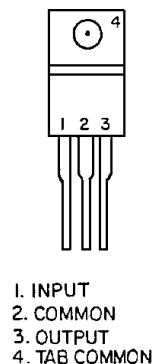

U35
EEPROM
19A704724P3 (MC3303P)

PIN CONFIGURATION

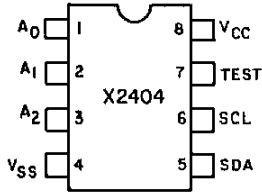

- 1 A₀ → TO V_{SS}
- 2 AND 3 A₁ AND A₂ ADDRESS INPUTS
- 4 V_{SS}
- 5 SDA SERIAL DATA BUS
- 6 SCL SERIAL CLOCK
- 7 TEST INPUT → TO V_{SS}
- 8 V_{CC}

FUNCTION DIAGRAM

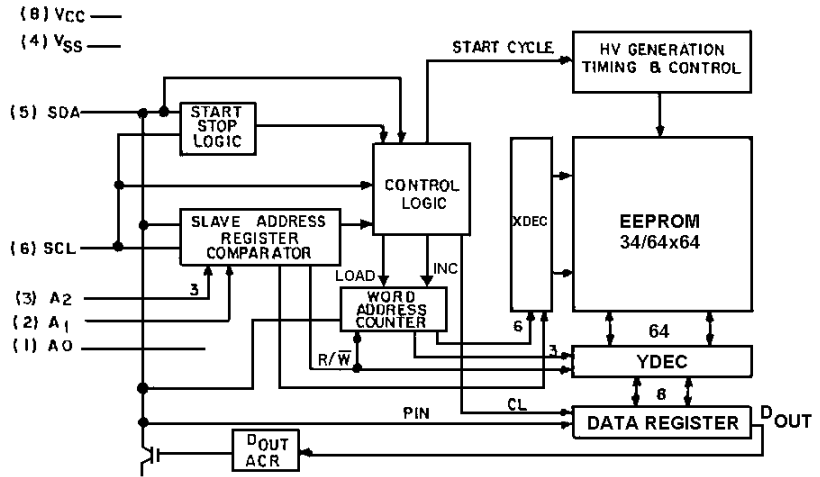

U41
DUAL DATA FLIP-FLOP
19A700037P335 (74LS74A)

| Inputs | | | | Outputs | |
|--------|-----|-----|---|----------------|------------------------|
| PR | CLR | CLK | D | Q | \bar{Q} |
| L | H | X | X | H | L |
| H | L | X | X | L | H |
| L | L | X | X | H* | H* |
| H | H | ↑ | H | H | L |
| H | H | ↑ | L | L | H |
| H | H | L | X | Q ₀ | \bar{Q} ₀ |

Notes: Q₀ = the level of Q before the indicated input conditions were established.
 *This configuration is nonstable; that is, it will not persist when preset and clear inputs return to their inactive (high) level.

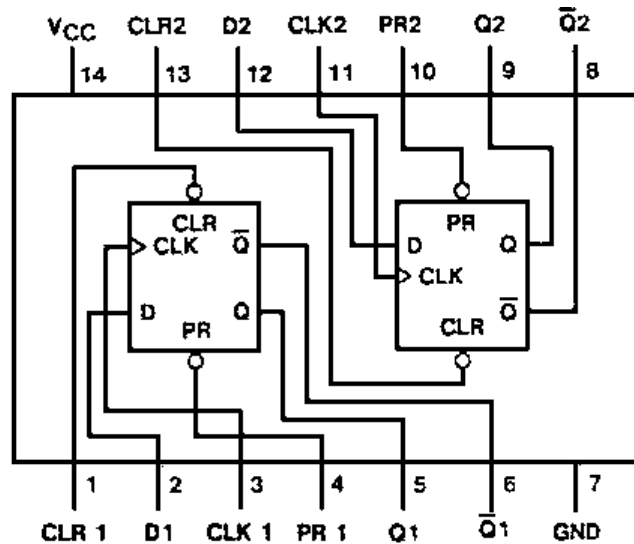

U43
DUAL RETRIGGERABLE MONOSTABLE
MULTIVIBRATOR WITH CLEAR CLOCK
19A700037P354 (74LS123)

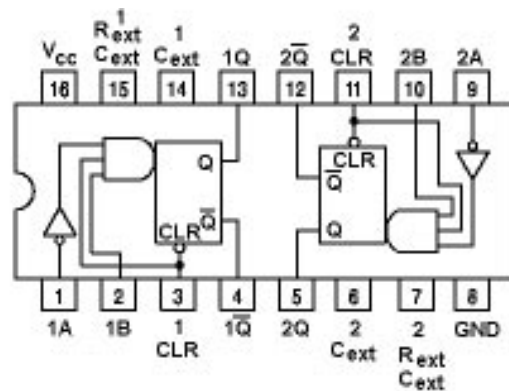

**GETC SHELF ASSEMBLY
19D901868G5
19D901868G6**

| SYMBOL | PART NUMBER | DESCRIPTION |
|---------------|---------------|---|
| A1 | | ----- ASSEMBLIES ----- GETC LOGIC BOARD 188D6500G1 (Used in G5) 188D6500G4 (Used in G6) ----- CAPACITORS ----- |
| C1 and C2 | 19A701624P118 | Ceramic: 27 pF ±5%, 500 VDCW, temp coef N80 ±30 PPM/°C. |
| C3 | 19A702250P211 | |
| C5 | 19A701534P3 | Tantalum: 0.47 µF ± 20%, 35 VDCW. |
| C10 | 19A701534P19 | Tantalum: 47 µF ±20%, 16 VDCW. |
| C11 thru C13 | 19A701534P8 | Tantalum: 22 µF ±20%, 16 VDCW. |
| C14 thru C20 | T644ACP310K | Polyester: .010 µF ±10%, 50 VDCW. |
| C37 thru C41 | T644ACP310J | Polyester: .010 µF ±5%, 50 VDCW. |
| C47 | 19A701534P7 | Tantalum: 10 µF ±20%, 16 VDCW. |
| C48 | T644ACP310K | Polyester: .010 µF ±10%, 50 VDCW. |
| C49 | 19A701534P7 | Tantalum: 10 µF ±20%, 16 VDCW. |
| C51 | 19A701534P7 | Tantalum: 10 µF ±20%, 16 VDCW. |
| C52 | T644ACP310K | Polyester: .010 µF ±10%, 50 VDCW. |
| C53 | 19A701534P7 | Tantalum: 10 µF ±20%, 16 VDCW. |
| C54 | 5496267P20 | Tantalum: 47 µF ± 20%, 35 VDCW; sim to Sprague Type 150D. |
| C55 | 19A701534P2 | Tantalum: 0.22 µF ±20%, 35 VDCW. |
| C56 | 19A701534P4 | Tantalum: 1 µF ± 20%, 35 VDCW. |
| C57 | 19A701534P8 | Tantalum: 22 µF ±20%, 16 VDCW. |
| C58 | 19A703314P9 | Electrolytic: 4.7 µF ±20%, 50 VDCW. |
| C59 | 19A701534P8 | Tantalum: 22 µF ±20%, 16 VDCW. |
| C60 | 19A703314P9 | Electrolytic: 4.7 µF ±20%, 50 VDCW. |
| C61 and C62 | 19A701534P8 | Tantalum: 22 µF ±20%, 16 VDCW. |
| C63 | 19A703314P9 | Electrolytic: 4.7 µF ±20%, 50 VDCW. |
| C64 | 19A701534P8 | Tantalum: 22 µF ±20%, 16 VDCW. |
| C65 | 5496267P20 | Tantalum: 47 µF ± 20%, 35 VDCW; sim to Sprague Type 150D. |
| C66 thru C69 | 19A703314P4 | Electrolytic: 47 µF -10+50% tol, 16 VDCW; sim to Panasonic LS Series. |
| C70 thru C93 | T644ACP310K | Polyester: .010 µF ±10%, 50 VDCW. |
| C94* | T644ACP247J | Polyester: .0047 µF ±5%, 50 VDCW. |
| C100 | T644ACP310K | Polyester: .010 µF ±10%, 50 VDCW. |
| C103 and C104 | 5496267P20 | Tantalum: 47 µF ± 20%, 35 VDCW; sim to Sprague Type 150D. |

| SYMBOL | PART NUMBER | DESCRIPTION |
|--------------|---------------|---|
| | | ----- DIODES ----- |
| D3 thru D8 | 19A700028P1 | Silicon: 75 mA, 75 PIV; sim to 1N4148. |
| D9 | 19A700025P2 | Silicon, zener: 400 mW max; sim to BZX55-C2V7. |
| D10 thru D13 | 19J706030P2 | Silicon: sim to 1N4736A. |
| D14 thru D17 | 19A700028P1 | Silicon: 75 mA, 75 PIV; sim to 1N4148. |
| D19 thru D21 | 19A700028P1 | Silicon: 75 mA, 75 PIV; sim to 1N4148. |
| D22 and D23 | T324ADP1041 | Silicon: Rectifier; sim to 1N4004. |
| D24 thru D28 | 19A700028P1 | Silicon: 75 mA, 75 PIV; sim to 1N4148. |
| D29 thru D35 | T324ADP1041 | Silicon: Rectifier; sim to 1N4004. |
| D36 | 19A700028P1 | Silicon: 75 mA, 75 PIV; sim to 1N4148. |
| D38 thru D43 | 19A700028P1 | Silicon: 75 mA, 75 PIV; sim to 1N4148. |
| | | ----- LEDS ----- |
| H1 thru H7 | 162B3011P0002 | Light Emitting Diode: Red; sim to GE 22L-2. |
| | | ----- JACKS ----- |
| J3 | 19A705181P1 | Connector: 64 contacts; sim to Burndx Cat. RP196B32R1G02Z1. |
| J6 and J7 | 19A704852P146 | Connector, header: 16-pin, right-angle mount; sim to Molex 22-12-2164. |
| J8 and J9 | 19A704852P136 | Connector, printed wire, two part: 6 contacts; sim to Dupont Berg 22-12-2064. |
| J10 | 19A116659P173 | Printed wire, two part: 4 contacts, sim to Molex 09-75-1041. |
| J11 thru J18 | 19A703248P12 | Post: Gold Plated, 13 mm length. |
| J19 | 19A704852P136 | Connector, printed wire, two part: 6 contacts; sim to Dupont Berg 22-12-2064. |
| J20 and J21 | 19A703248P12 | Post: Gold Plated, 13 mm length. |
| J24 thru J26 | 19A703248P12 | Post: Gold Plated, 13 mm length. |
| J27 | 19A704852P136 | Connector, printed wire, two part: 6 contacts; sim to Dupont Berg 22-12-2064. |
| J28 and J29 | 19A703248P12 | Post: Gold Plated, 13 mm length. |
| J40 | 19A703248P12 | Post: Gold Plated, 13 mm length. |
| J44 | 19A703248P12 | Post: Gold Plated, 13 mm length. |

PARTS LIST

LBI-39203

| SYMBOL | PART NUMBER | DESCRIPTION |
|-------------------------|---------------|--|
| J46 thru J48 | 19A703248P12 | Post: Gold Plated, 13 mm length. |
| J49 | 19A704779P59 | Connector, printed wiring: 10 contacts; sim to Molex 22-18-2103. |
| J50 thru J55 | 19A703248P12 | Post: Gold Plated, 13 mm length. |
| J60 thru J62 | 19A703248P12 | Post: Gold Plated, 13 mm length. |
| J67 thru J69 | 19A703248P12 | Post: Gold Plated, 13 mm length. |
| J71 thru J75 | 19A703248P12 | Post: Gold Plated, 13 mm length. |
| J106 | 19A704852P32 | Connector, printed wiring: 2 Pins. |
| ----- INDUCTORS ----- | | |
| L1 thru L3 | 19A704921P1 | Coil. |
| ----- PLUGS ----- | | |
| P11 thru P18 | 19A702104P2 | Connector: Shorting Jumper, Gold Plated. (Housing Color: White). |
| P21 | 19A702104P2 | Connector: Shorting Jumper, Gold Plated. (Housing Color: White). |
| P24 thru P26 | 19A702104P2 | Connector: Shorting Jumper, Gold Plated. (Housing Color: White). |
| P28 and P29 | 19A702104P2 | Connector: Shorting Jumper, Gold Plated. (Housing Color: White). |
| P44 | 19A702104P2 | Connector: Shorting Jumper, Gold Plated. (Housing Color: White). |
| P46 thru P48 | 19A702104P2 | Connector: Shorting Jumper, Gold Plated. (Housing Color: White). |
| P50 thru P54 | 19A702104P2 | Connector: Shorting Jumper, Gold Plated. (Housing Color: White). |
| P60 thru P62 | 19A702104P2 | Connector: Shorting Jumper, Gold Plated. (Housing Color: White). |
| P67 thru P69 | 19A702104P2 | Connector: Shorting Jumper, Gold Plated. (Housing Color: White). |
| P71 thru P75 | 19A702104P2 | Connector: Shorting Jumper, Gold Plated. (Housing Color: White). |
| ----- TRANSISTORS ----- | | |
| Q2 thru Q6 | 19A700023P2 | Silicon, NPN: sim to 2N3904. |
| Q7 | RYN 123 640/1 | N-Channel SIPMOS, Enhancement mode FET, TO-92 pkg. Sim to BSS 295. |
| Q8 thru Q10 | 19A700023P2 | Silicon, NPN: sim to 2N3904. |
| Q11 | 19A700022P2 | Silicon, PNP: sim to 2N3906. |
| Q12 | 19A116375P1 | Silicon, PNP. |
| Q13 | 19A700054P1 | Silicon, NPN, 60 w; sim to BD-201. |

| SYMBOL | PART NUMBER | DESCRIPTION |
|-----------------------|---------------|---|
| Q14 and Q15 | 19A700023P2 | Silicon, NPN: sim to 2N3904. |
| Q16 | RYN 123 640/1 | N-Channel SIPMOS, Enhancement mode FET, TO-92 pkg. Sim to BSS 295. |
| Q17 | 19A700022P2 | Silicon, PNP: sim to 2N3906. |
| Q18 thru Q21 | 19A700023P2 | Silicon, NPN: sim to 2N3904. |
| ----- RESISTORS ----- | | |
| R1 | 19B800784P106 | Variable: 5K ohms \pm 20%, 1/2 w. |
| R2 | 19B800784P105 | Variable: 1K ohms \pm 20%, 350 VDCW, .5 w. |
| R6 and R7 | H212CRP310C | Deposited carbon: 10K ohms \pm 5%, 1/4 w. |
| R8 and R9 | 19A701630P2 | Resistor, network: 9 resistors rated 10K ohms \pm 2%, 50 VDCW; sim to Bourns 4310R-101-103. |
| R10 | H212CRP510C | Deposited carbon: 1M ohms \pm 5%, 1/4 w. |
| R12 | 19A701537P1 | Composition: 10M ohms \pm 5%, 1/4 w. |
| R13 | 19A701250P446 | Metal film: 294K ohm \pm 1%, 250 VDCW, 1/4 w. |
| R14 | H212CRP322C | Deposited carbon: 22K ohms \pm 5%, 1/4 w. |
| R15 | 19A701537P1 | Composition: 10M ohms \pm 5%, 1/4 w. |
| R16 | H212CRP310C | Deposited carbon: 10K ohms \pm 5%, 1/4 w. |
| R17 | 19A701250P273 | Metal film: 5.6K ohms \pm 1%, 250 VDCW, 1/4 w. |
| R18 | H212CRP147C | Deposited carbon: 470 ohms \pm 5%, 1/4 w. |
| R19 | 19A701250P301 | Metal film: 10K ohms \pm 1%, 1/4 w. |
| R20 and R21 | H212CRP310C | Deposited carbon: 10K ohms \pm 5%, 1/4 w. |
| R22 | 19A701537P1 | Composition: 10M ohms \pm 5%, 1/4 w. |
| R31 | 19B235029P8 | Variable: 10K ohms, \pm 10%, 1/2 w. |
| R32 | H212CRP510C | Deposited carbon: 1M ohms \pm 5%, 1/4 w. |
| R33 | H212CRP239C | Deposited carbon: 3.9K ohms \pm 5%, 1/4 w. |
| R36 | 19A701250P176 | Metal film: 604 ohms \pm 1%, 1/4 w. |
| R38 | H212CRP122C | Deposited carbon: 220 ohms \pm 5%, 1/4 w. |
| R39 and R40 | 19A701630P2 | Resistor, network: 9 resistors rated 10K ohms \pm 2%, 50 VDCW; sim to Bourns 4310R-101-103. |
| R41 | H212CRP210C | Deposited carbon: 1K ohms \pm 5%, 1/4 w. |
| R42 | H212CRP222C | Deposited carbon: 2.2K ohms \pm 5%, 1/4 w. |
| R43 | H212CRP210C | Deposited carbon: 1K ohms \pm 5%, 1/4 w. |
| R44 thru R53 | H212CRP310C | Deposited carbon: 10K ohms \pm 5%, 1/4 w. |
| R54 thru R59 | H212CRP156C | Deposited carbon: 560 ohms \pm 5%, 1/4 w. |
| R60 | H212CRP312C | Deposited carbon: 12K ohms \pm 5%, 1/4 w. |

| SYMBOL | PART NUMBER | DESCRIPTION |
|----------------------|---------------|---|
| R61 | H212CRP310C | Deposited carbon: 10K ohms $\pm 5\%$, 1/4 w. |
| R62 | H212CRP239C | Deposited carbon: 3.9K ohms $\pm 5\%$, 1/4 w. |
| R63 | H212CRP310C | Deposited carbon: 10K ohms $\pm 5\%$, 1/4 w. |
| R64 | H212CRP210C | Deposited carbon: 1K ohms $\pm 5\%$, 1/4 w. |
| R67 | H212CRP247C | Deposited carbon: 4.7K ohms $\pm 5\%$, 1/4 w. |
| R68 | H212CRP318C | Deposited carbon: 18K ohms $\pm 5\%$, 1/4 w. |
| R69 | 19A701250P388 | Metal film: 80.6K ohms $\pm 1\%$, 250 VDCW, 1/4 w. |
| R70 | 19A701250P358 | Metal film: 2.7 ohms $\pm 5\%$, 1/4 w. |
| R71 | 19A701250P383 | Metal film: 71.5K ohms $\pm 1\%$, 1/4 w. |
| R72 | 19A701250P384 | Metal film: 73.2K ohms $\pm 1\%$, 1/4 w. |
| R73 | 19A701250P383 | Metal film: 71.5K ohms $\pm 1\%$, 1/4 w. |
| R74 | 19A701250P391 | Metal film: 86.6K ohms $\pm 1\%$, 1/4 w. |
| R75 | 19A701250P325 | Metal film: 17.8K ohms $\pm 1\%$, 1/4 w. |
| R76 | 19A701250P383 | Metal film: 71.5K ohms $\pm 1\%$, 1/4 w. |
| R77 | 19A701250P382 | Metal film: 69.8K ohms $\pm 1\%$, 1/4 w. |
| R78 | 19A701250P383 | Metal film: 71.5K ohms $\pm 1\%$, 1/4 w. |
| R79 | 19A701250P350 | Metal film: 32.4K ohms $\pm 1\%$, 1/4 w. |
| R80 thru R83 | H212CRP310C | Deposited carbon: 10K ohms $\pm 5\%$, 1/4 w. |
| R84 | H212CRP382C | Deposited carbon: 82K ohms $\pm 5\%$, 1/4 w. |
| R85 | H212CRP318C | Deposited carbon: 18K ohms $\pm 5\%$, 1/4 w. |
| R86 | 19A701250P388 | Metal film: 80.6K ohms $\pm 1\%$, 250 VDCW, 1/4 w. |
| R87 | 19A701250P358 | Metal film: 2.7 ohms $\pm 5\%$, 1/4 w. |
| R88 | 19A701250P383 | Metal film: 71.5K ohms $\pm 1\%$, 1/4 w. |
| R89 | 19A701250P384 | Metal film: 73.2K ohms $\pm 1\%$, 1/4 w. |
| R90 | 19A701250P383 | Metal film: 71.5K ohms $\pm 1\%$, 1/4 w. |
| R91 | 19A701250P391 | Metal film: 86.6K ohms $\pm 1\%$, 1/4 w. |
| R92 | 19A701250P325 | Metal film: 17.8K ohms $\pm 1\%$, 1/4 w. |
| R93 | 19A701250P383 | Metal film: 71.5K ohms $\pm 1\%$, 1/4 w. |
| R94 | 19A701250P382 | Metal film: 69.8K ohms $\pm 1\%$, 1/4 w. |
| R95 | 19A701250P383 | Metal film: 71.5K ohms $\pm 1\%$, 1/4 w. |
| R96 | 19A701250P350 | Metal film: 32.4K ohms $\pm 1\%$, 1/4 w. |
| R97 and R98 | H212CRP310C | Deposited carbon: 10K ohms $\pm 5\%$, 1/4 w. |
| R99 | H212CRP347C | Deposited carbon: 47K ohms $\pm 5\%$, 1/4 w. |
| R100 | H212CRP410C | Deposited carbon: 100K ohms $\pm 5\%$, 1/4 w. |
| R101 | H212CRP368C | Deposited carbon: 68K ohms $\pm 5\%$, 1/4 w. |
| R103 thru R105 | H212CRP310C | Deposited carbon: 10K ohms $\pm 5\%$, 1/4 w. |
| R116 | 19A701250P201 | Metal film: 1K ohms $\pm 1\%$, 250 VDCW, 1/4 w. |
| R117 and R118 | H212CRP310C | Deposited carbon: 10K ohms $\pm 5\%$, 1/4 w. |
| R119 | H212CRP210C | Deposited carbon: 1K ohms $\pm 5\%$, 1/4 w. |

| SYMBOL | PART NUMBER | DESCRIPTION |
|----------------------|---------------|---|
| R120 | H212CRP310C | Deposited carbon: 10K ohms $\pm 5\%$, 1/4 w. |
| R121 | 19A701630P2 | Resistor, network: 9 resistors rated 10K ohms $\pm 2\%$, 50 VDCW; sim to Bourns 4310R-101-103. |
| R123 thru R125 | H212CRP210C | Deposited carbon: 1K ohms $\pm 5\%$, 1/4 w. |
| R126 | 19A700113P63 | Composition: 1K ohms $\pm 5\%$, 1/2 w. |
| R127 | 3R77P511J | Composition: 510 ohms $\pm 5\%$, 1/2 w. |
| R128 | 19A700113P19 | Composition: 15 ohms $\pm 5\%$, 1/2 w. |
| R129 | 19A701250P434 | Metal film: 221 K ohms $\pm 1\%$, 250 VDCW, 1 w. |
| R130 | 19A700050P13 | Wirewound: 1 ohms $\pm 10\%$, 2 w. |
| R131 | 19A701250P301 | Metal film: 10K ohms $\pm 1\%$, 1/4 w. |
| R132 | 19A701250P266 | Metal film: 4.75K ohms $\pm 1\%$, 1/4 w. |
| R133 | H212CRP310C | Deposited carbon: 10K ohms $\pm 5\%$, 1/4 w. |
| R134 | H212CRP210C | Deposited carbon: 1K ohms $\pm 5\%$, 1/4 w. |
| R135 | H212CRP310C | Deposited carbon: 10K ohms $\pm 5\%$, 1/4 w. |
| R136 | 5493035P2 | Wirewound: 1 ohm $\pm 5\%$, 5 w. |
| R137 | H212CRP310C | Deposited carbon: 10K ohms $\pm 5\%$, 1/4 w. |
| R138 | H212CRP315C | Deposited carbon: 15K ohms $\pm 5\%$, 1/4 w. |
| R139 and R140 | H212CRP310C | Deposited carbon: 10K ohms $\pm 5\%$, 1/4 w. |
| R141 | 19B800784P108 | Variable: 10K ohms $\pm 20\%$, 1/2 w. |
| R142 | H212CRP322C | Deposited carbon: 22K ohms $\pm 5\%$, 1/4 w. |
| R143 | 19A701537P1 | Composition: 10M ohms $\pm 5\%$, 1/4 w. |
| R144 | H212CRP347C | Deposited carbon: 47K ohms $\pm 5\%$, 1/4 w. |
| R145 | H212CRP310C | Deposited carbon: 10K ohms $\pm 5\%$, 1/4 w. |
| R146 | 19A701250P176 | Metal film: 604 ohms $\pm 1\%$, 1/4 w. |
| R147 | H212CRP368C | Deposited carbon: 68K ohms $\pm 5\%$, 1/4 w. |
| R148 | H212CRP110C | Deposited carbon: 100 ohms $\pm 5\%$, 1/4 w. |
| R149 | 19A700184P1 | Jumper. |
| R151 and R152 | H212CRP312C | Deposited carbon: 12K ohms $\pm 5\%$, 1/4 w. |
| R153 | H212CRP239C | Deposited carbon: 3.9K ohms $\pm 5\%$, 1/4 w. |
| R154 thru R161 | H212CRP110C | Deposited carbon: 100 ohms $\pm 5\%$, 1/4 w. |
| R163 and R164 | H212CRP110C | Deposited carbon: 100 ohms $\pm 5\%$, 1/4 w. |
| R168 and R169 | H212CRP310C | Deposited carbon: 10K ohms $\pm 5\%$, 1/4 w. |
| R171 and R173 | H212CRP310C | Deposited carbon: 10K ohms $\pm 5\%$, 1/4 w. |
| R174 | H212CRP410C | Deposited carbon: 100K ohms $\pm 5\%$, 1/4 w. |
| R175 | H212CRP310C | Deposited carbon: 10K ohms $\pm 5\%$, 1/4 w. |

PARTS LIST

LBI-39203

| SYMBOL | PART NUMBER | DESCRIPTION |
|---------------------------------|----------------|--|
| R176 | H212CRP110C | Deposited carbon: 100 ohms ±5%, 1/4 w. |
| R177 | H212CRP239C | Deposited carbon: 3.9K ohms ±5%, 1/4 w. |
| R178 and R179 | H212CRP410C | Deposited carbon: 100K ohms ±5%, 1/4 w. |
| ----- VARISTORS ----- | | |
| RV1 thru RV11 | 19A705677P3 | Arrester, Electrical Surge (MOV Varistor): Sim to Harris V39ZT1 (marked 39Z1). |
| ----- SWITCHES ----- | | |
| S1 thru S3 | 19B800010P2 | Dual-Inline-Package: 8 Circuits; sim to CTS 206-8. |
| S4 | 19A701324P1 | Push-Button: sim to IEE/Schadown 210091. |
| ----- TRANSFORMERS ----- | | |
| T1 and T2 | 19A703656P1 | Audio Frequency: sim to Nova Magnetics 5577-06-0001. |
| ----- TEST POINTS ----- | | |
| TP127 and TP127 | 19A703248P12 | Post: Gold Plated, 13 mm length. |
| ----- INTEGRATED CIRCUITS ----- | | |
| U1 | 19A705557P1 | Digital: 8-Bit Microcomputer; sim to P80C32 (Used in 188D6500G1). |
| U1 | RYT 121 6060/A | Digital: 8-Bit Microcomputer; sim to P80C320 (used in 188D6500G4). |
| U3 | 19A705558P1 | Digital: 8K x 8 RAM; sim to MCM6064P-12. |
| U4 | ROP 101 688/3 | Integrated Circuit, Custom Modem. |
| U5 | 19A703471P2 | Digital: Octal Data Latch; sim to 74HC373. |
| U6 | 19A703471P8 | Digital: Octal Tri-State Transceiver; sim to 74HC245. |
| U7 thru U9 | 19A703471P1 | Digital: Octal Tri-State Buffer; sim to 74HC244. |
| U10 | 19A700037P363 | Digital: Dual 2-to-1 Decoder/Demultiplexer; sim to 74LS155. |
| U11 thru U13 | 19A700176P1 | Digital: Hex Inverting Buffer/Converter; sim to 4049UB. |
| U14 | 19A116704P1 | Digital: Quad Line Driver; sim to 1488. |
| U15 | 19A700029P38 | Digital: CMOS Triple 2 Channel Multiplexer; sim to 4053. |
| U17 | 19A134764P2 | Linear: Dual Voltage Comparator; sim to LM393N. |
| U18 | 19A700086P4 | Linear: Dual Op Amp; sim to 4558. |
| U19 | ROP 101 688/3 | Integrated Circuit, Custom Modem. |
| U20 and U21 | 19A704380P11 | Digital: CMOS Octal Data Flip-Flop; sim to 74HC273. |
| U22 | 19A703483P1 | Digital: CMOS Quad 2-Input NOR Gate; sim to 74HC02. |
| U23 thru U26 | 19A116180P75 | Digital: Hex Open Collector Inverter; sim to 7406. |

| SYMBOL | PART NUMBER | DESCRIPTION |
|---------------------------|---------------|--|
| U27 | 19A116704P2 | Digital: Quad Line Receiver; sim to 1489. |
| U28 | 19A116704P1 | Digital: Quad Line Driver; sim to 1488. |
| U29 | 19A700176P1 | Digital: Hex Inverting Buffer/Converter; sim to 4049UB. |
| U30 | 19A704883P1 | Linear: Quad Op Amp; sim to MC3303P. |
| U31 | 19A134764P2 | Linear: Dual Voltage Comparator; sim to LM393N. |
| U32 and U33 | 19A704883P1 | Linear: Quad Op Amp; sim to MC3303P. |
| U34 | 19A700029P38 | Digital: CMOS Triple 2 Channel Multiplexer. |
| U35 | 19A704724P3 | Digital: EEPROM; 512K X 8. |
| U37 | 19A704883P1 | Linear: Quad Op Amp; sim to MC3303P. |
| U38 | 19A704380P11 | Digital: CMOS Octal Data Flip-Flop; sim to 74HC273. |
| U39 | 19A134718P2 | Linear: -12 Volt Regulator; sim to uA7912U. |
| U40 | 19A134717P2 | Linear: 12 Volt Regulator; sim to MC7812CT. |
| U41 | 19A700037P335 | Digital: Dual Data Flip-Flop; sim to 74LS74A. |
| U42 | 19A700029P7 | Digital: QUAD 2-INPUT NAND GATE. |
| U43 | 19A700037P354 | Digital: Dual Retriggerable Monostable Multivibrator with Clear Clock; sim to 74LS123. |
| ----- SOCKETS ----- | | |
| XU1 | 19A700156P5 | Socket, IC: 40 Pins, Tin Plated. |
| XU2 thru XU4 | 19A700156P3 | Socket, IC: 28 Pins, Tin Plated. |
| XU19 | 19A700156P3 | Socket, IC: 28 Pins, Tin Plated. |
| XU35 | 19A700156P15 | Socket, IC: 8 Pins, Tin Plated. |
| ----- CRYSTALS ----- | | |
| Y1 | 19A702511G23 | Crystal Unit: Quartz; 11.059200 MHZ. |
| ----- MISCELLANEOUS ----- | | |
| 5 | N402P35B6 | Washer, Flat. |
| 6 | 19A703248P12 | Post: Gold Plated, 13 mm length. |
| 7 | N80P9005B6 | Machine screw, pan head, steel, No. 4-40 UNC x 5/16". |
| 8 | N404P11B6 | Lockwasher, internal tooth: No. 4. |
| 9 | 7141225P2 | Nut, Hex: 4-40. |
| 11 | 19A134521P1 | Lens, red. (XMIT). |
| 12 | 19A134521P6 | Lens. |
| 13 | 19A702917P7 | Heat Sink, Transistor: Sim to Thermalloy Cat 6030B-TT. |
| 14 | 19B232901P2 | Support. |
| 18 | 19A116837P3 | Nut, Clinch. |
| 19 | 19A700068P1 | Insulator, bushing. |
| 20 | N80P9006B6 | Machine screw, pan head, steel, No. (qty: 2 ea). |
| 21 | N402P5B6 | Washer, plain nar steel (qty: 4 ea). |

| SYMBOL | PART NUMBER | DESCRIPTION |
|-------------------|-------------|---|
| A2 | | REGULATOR ASSEMBLY 19C336816G2 |
| | | ----- RESISTORS ----- |
| R1 and R2 | 5493035P1 | Wirewound: 5 ohms ±5%, 5 watt; sim to Hamilton Hall Type HR-5W. |
| | | ----- TERMINAL BOARDS ----- |
| TB1 and TB2 | 7775500P11 | Phen: 5 terminals. |
| | | ----- INTEGRATED CIRCUITS - - - |
| U1 and U2 | 19A134717P1 | Linear: 5 Volt Regulator; sim to MC7805CT. |
| | | MISCELLANEOUS PARTS FOR 19D901868G5, G6 |
| 2 | 19C851553G1 | Tray. |
| 3 | 19C851587G1 | Shelf Assembly. |
| 7 | 19A115594P2 | Grommet. |
| 9 | 19A115204P1 | Grease. |
| 14 | 19B235048P1 | Ground cable. |
| 15 | 19B201109P1 | Rivet, Blind |
| 18 | 19B235310P5 | Nameplate, Blank. |

**GETC LIGHTNING-PROTECTION CIRCUITRY
GROUNDING KIT
344A4500G1**

| SYMBOL | PART NUMBER | DESCRIPTION |
|--------|--------------|--|
| 2 | N80P13004B6 | Screw, Machine (qty 2). |
| 3 | 19B209260P1 | Solderless Terminal (qty 2). |
| 4 | N404P13B6 | Lock Washer (qty 4). |
| 5 | 19A116850P10 | Wire, Stranded; 16AWG Black (qty 2 @ 2 ft each). |
| 6 | 344A4060P1 | Connector; Split Bolt (qty 2). |

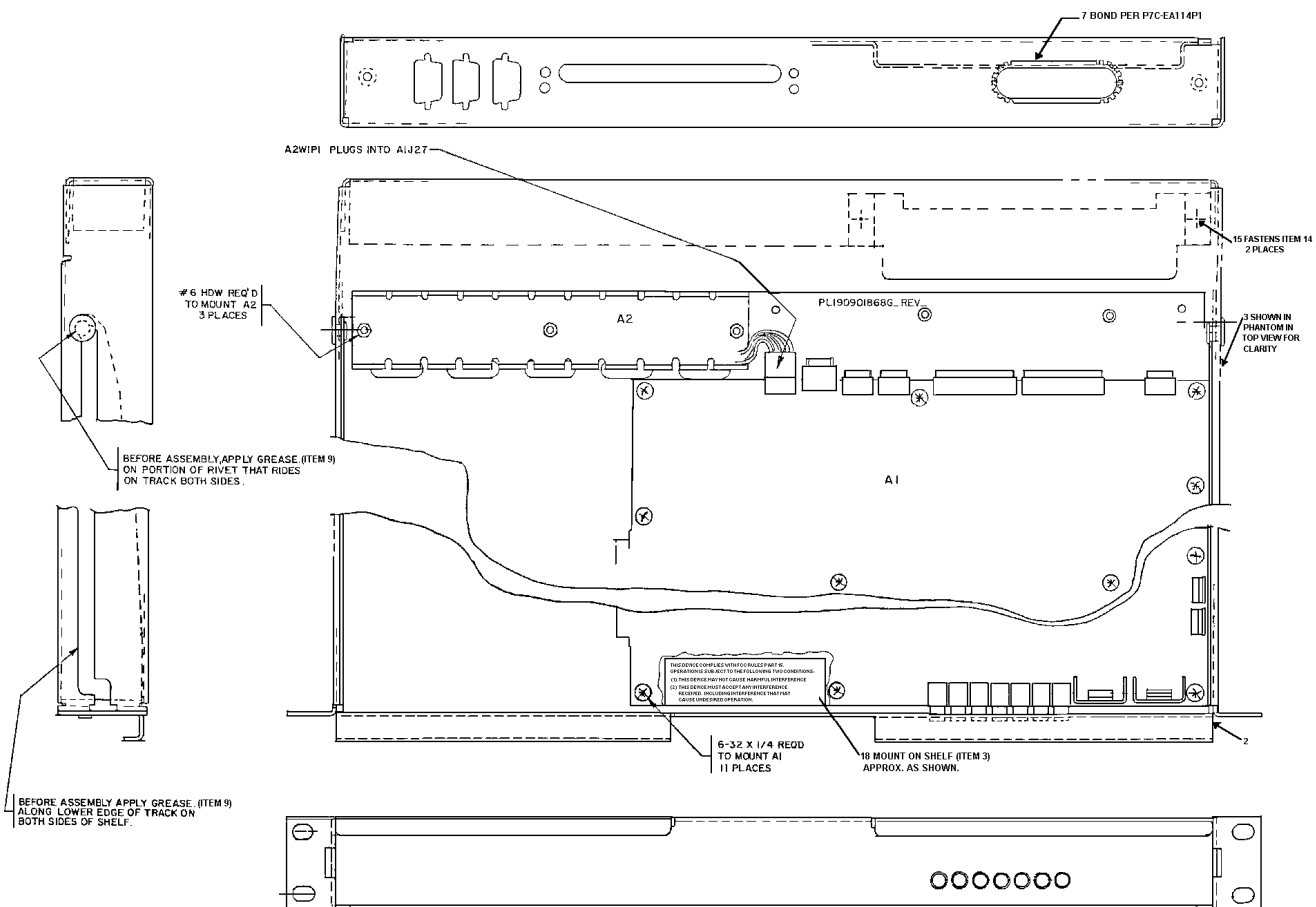

GETC SHELF ASSEMBLY
19D901868G5 or G6
 (19D901868, Sh. 2, Rev. 3)

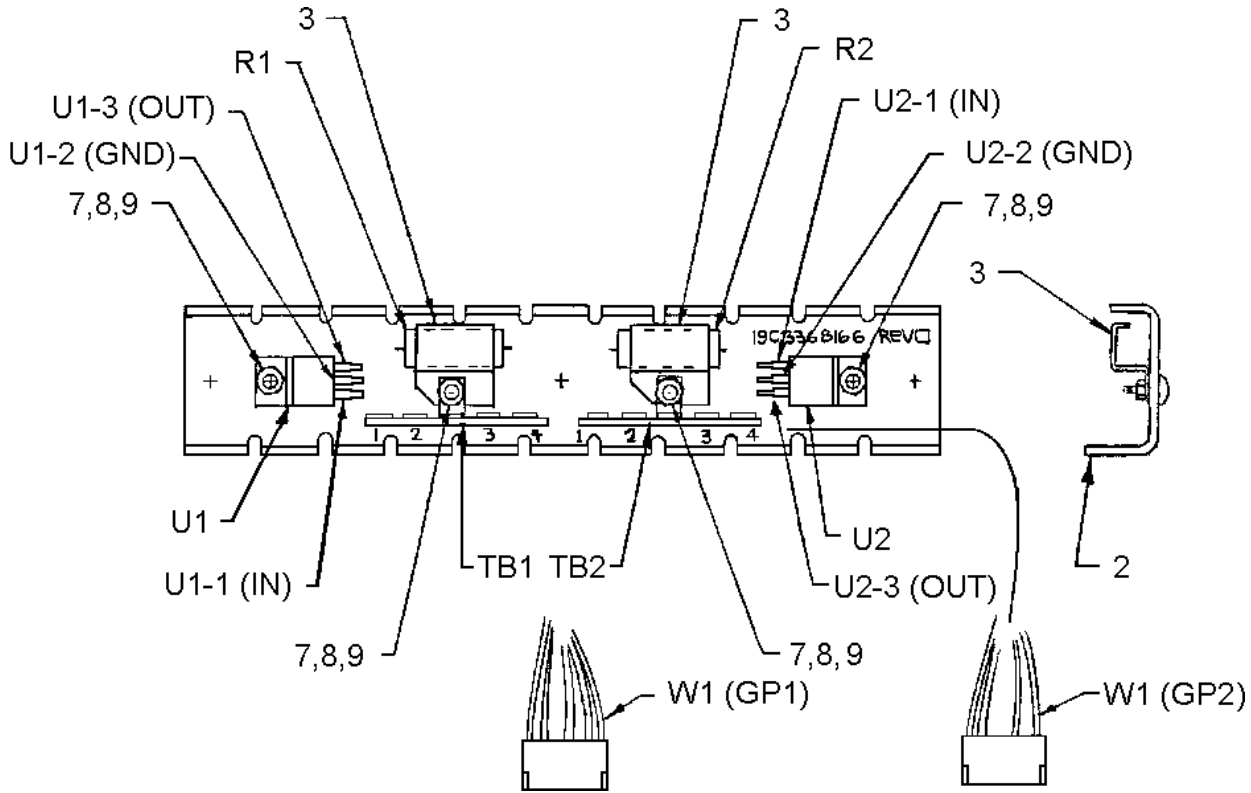

WIRING CHART

| WIRE | FROM | TO | REMARKS |
|---------|--------|-------|----------------|
| ST22-W | U1-1 | TB1-1 | +5V R.M. INPUT |
| R1 | TB1-1 | TB2-1 | |
| W1-W | W1P1-2 | TB1-1 | +5V R.M. INPUT |
| ST22-BK | U1-2 | TB1-2 | GROUND |
| ST22-BK | TB1-2 | TB2-2 | |
| ST22-BK | U2-2 | TB2-2 | |
| W1-BK | W1P1-3 | TB1-2 | |
| ST22-R | U1-3 | TB1-3 | +5V R.M. |
| W1-R | W1P1-1 | TB1-3 | |
| ST22-W | U2-1 | TB2-4 | +5V INPUT |
| R2 | TB2-1 | TB2-4 | |
| W1-W | W1P1-5 | TB2-4 | |
| ST22-BR | U2-3 | TB2-3 | +5V |
| W1-BR | W1P1-6 | TB2-3 | |
| W1-O | W1P1-4 | TB2-1 | +13.8V |

REGULATOR ASSEMBLY

19C336816G2

(19C336816, Rev. 6)

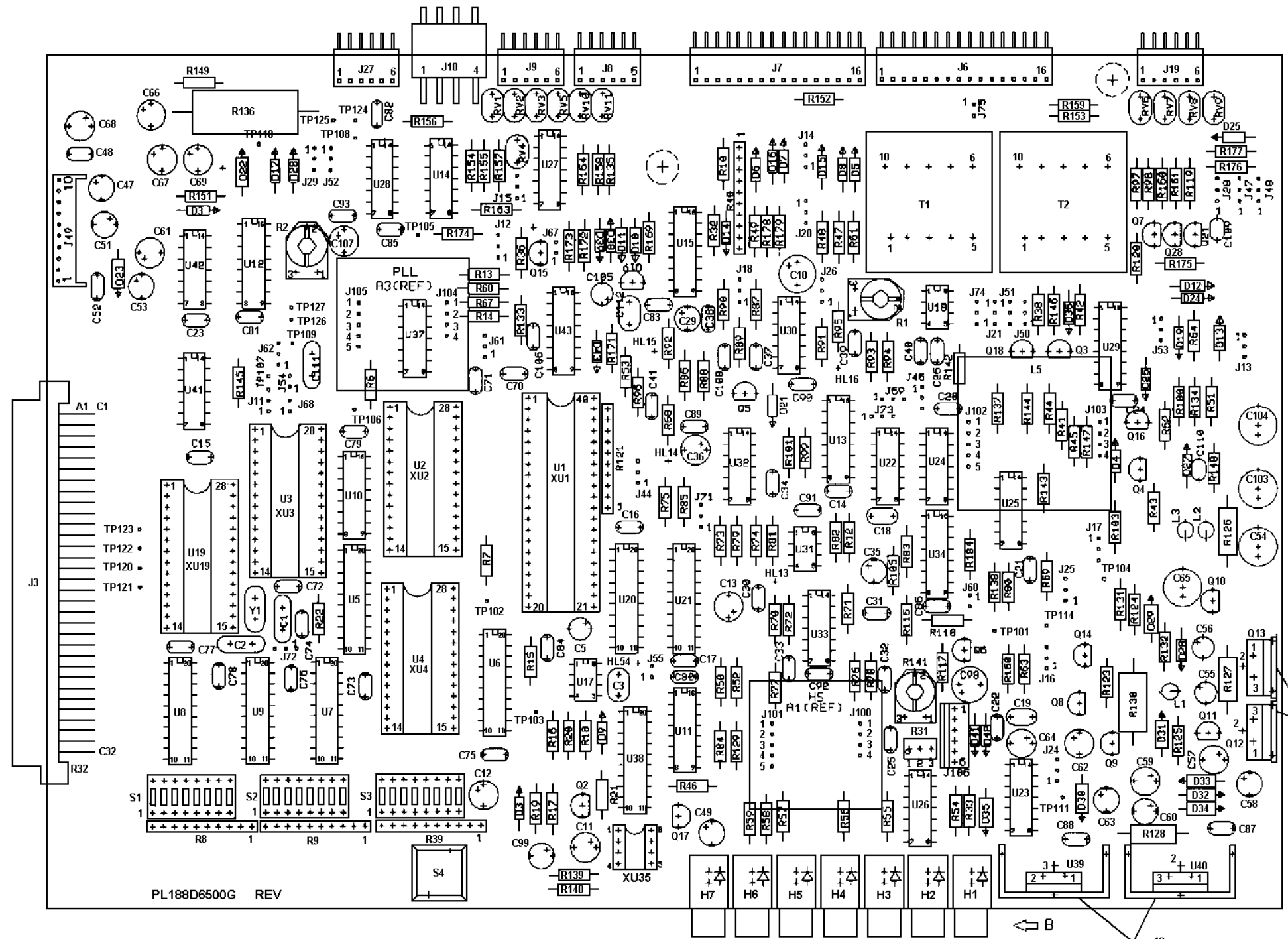

PL188D6500G REV

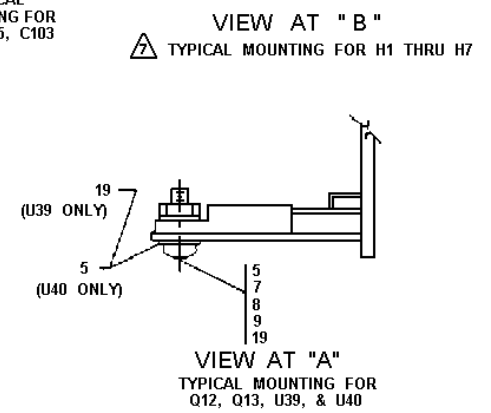
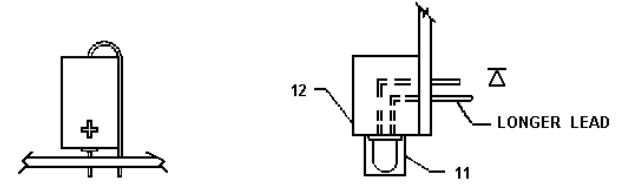
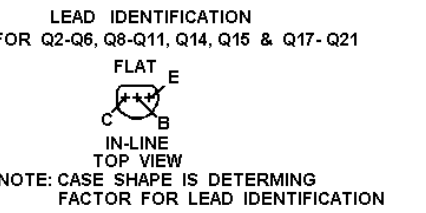
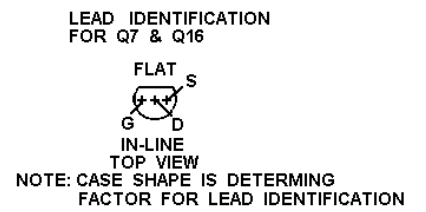

CAUTION
OBSERVE PRECAUTIONS FOR HANDLING ELECTROSTATIC SENSITIVE DEVICES

GETC LOGIC BOARD
188D6500G1 and G4

(188D6500, Sh. 1, Rev. 5)

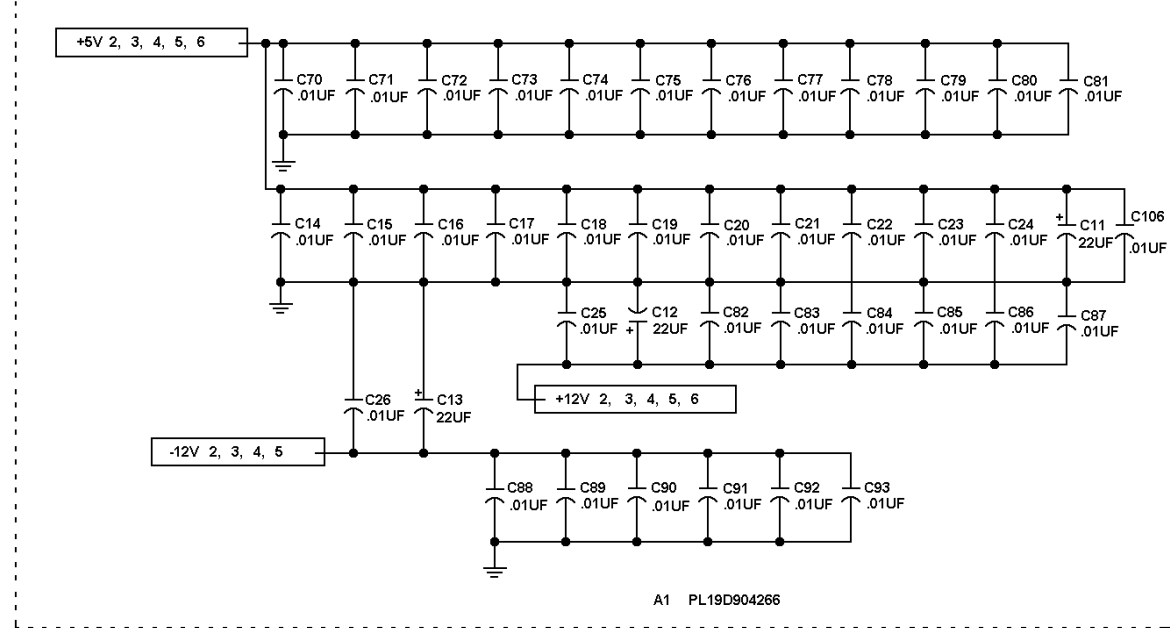

| | |
|-------------|------------|
| MODEL NO. | REV LETTER |
| P188D6500G1 | |

ALL RESISTORS ARE 1/4 WATT UNLESS OTHERWISE INDICATED
 RESISTOR VALUES IN OHMS UNLESS FOLLOWED BY MULTIPLIER K OR M.
 CAPACITOR VALUES IN F UNLESS FOLLOWED BY MULTIPLIER U, N OR P.
 INDUCTANCE VALUES IN H UNLESS FOLLOWED BY MULTIPLIER M OR U.

NOTES:

⚠ FOR JUMPER PLACEMENT. SEE 349A9793.

⚠ FOR A 6116 RAM (24 PINS). OFFSET DOWNWARD IN THE 28 PIN SOCKET.

| DEVICE | GND PIN NO | +5V PIN NO | +12 PIN NO | -12 PIN NO |
|--------|------------|------------|------------|------------|
| U1 | 20 | 40 | | |
| U2 | 14 | 28 | | |
| U3 | 14 | 26, 28 | | |
| U4 | 13 | 15 | | |
| U5 | 10 | 20 | | |
| U6 | 10 | 20 | | |
| U7 | 10 | 20 | | |
| U8 | 10 | 20 | | |
| U9 | 10 | 20 | | |
| U10 | 8 | 16 | | |
| U11 | 8 | 1 | | |
| U12 | 8 | 1 | | |
| U13 | 8 | 1 | | |
| U14 | 7 | | 14 | 1 |
| U15 | 6.8 | | 16 | 7 |
| U16 | | | 4 | 11 |
| U17 | 4 | | 8 | |
| U18 | | | 8 | 4 |
| U19 | 13 | 15 | | |
| U20 | 10 | 20 | | |
| U21 | 10 | 20 | | |
| U22 | 7 | 14 | | |
| U23 | 7 | 14 | | |
| U24 | 7 | 14 | | |
| U25 | 7 | 14 | | |
| U26 | 7 | 14 | | |
| U27 | 7 | 14 | | |
| U28 | 7 | | 14 | 1 |
| U29 | 8 | 1 | | |
| U30 | | | 4 | 11 |
| U31 | | | 8 | 4 |
| U32 | 3.5 | | 4 | 11 |
| U33 | | | 4 | 11 |
| U34 | 6.8 | | 16 | 7 |
| U35 | 4 | | | |
| U37 | | | 4 | 11 |
| U38 | 10 | 20 | | |
| U41 | 7 | 14 | | |
| U42 | 7 | 14 | | |
| U43 | 8 | 16 | | |

⚠ FOR ROCKWELL MODEM COMMUNICATIONS. CONNECT P11 TO J11 -1&2 AND P12 TO J12 -1&2
 ⚠ FOR RS232 COMMUNICATIONS. CONNECT P11 TO J11 -2&3 AND P12 TO J12 -2&3.

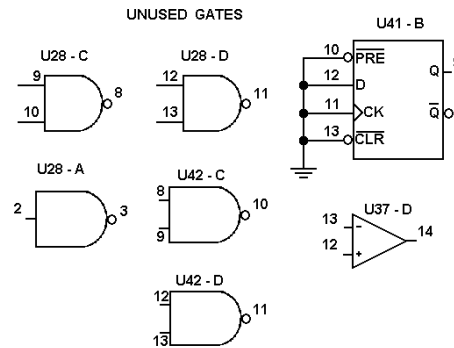
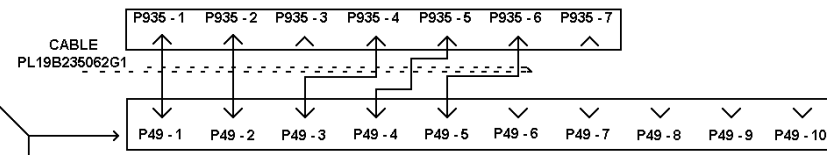
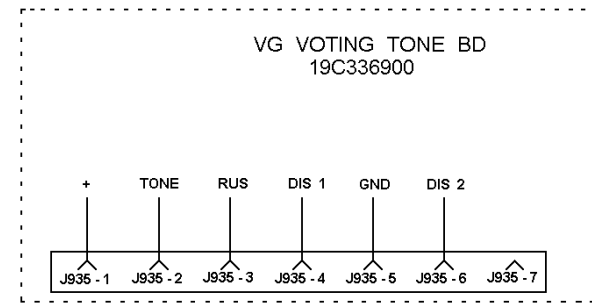
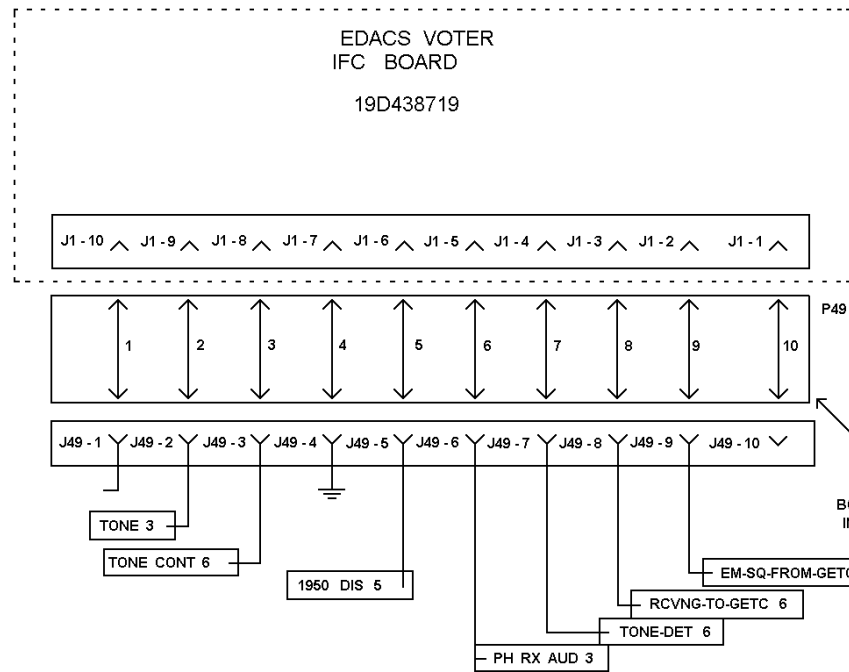

GETC SHELF ASSEMBLY
19D901868G5 and G6

(188D6822, Sh. 1, Rev. 1)

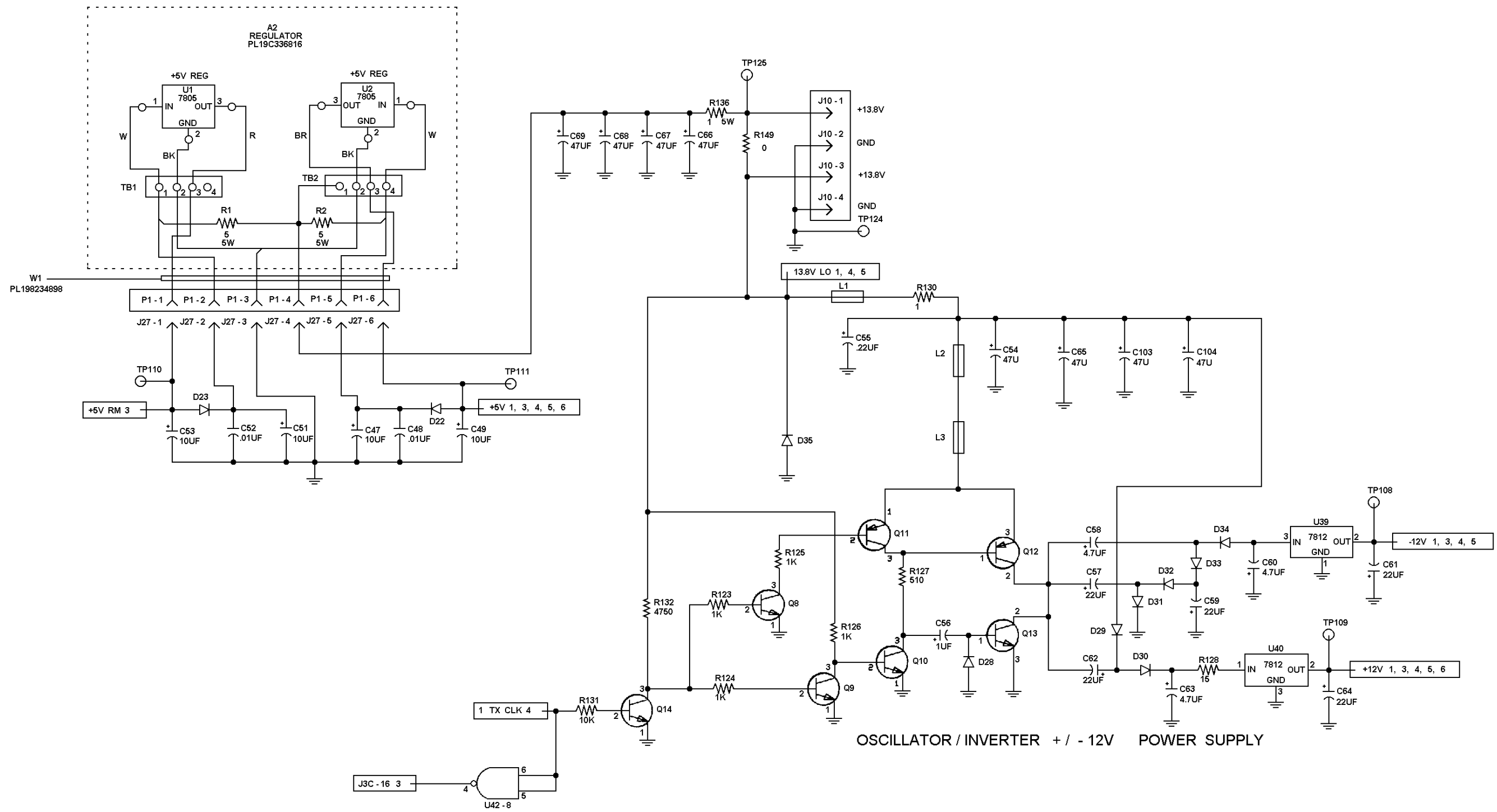

GETC SHELF ASSEMBLY
19D901868G5 and G6
(188D6822, Sh. 2, Rev. 1)

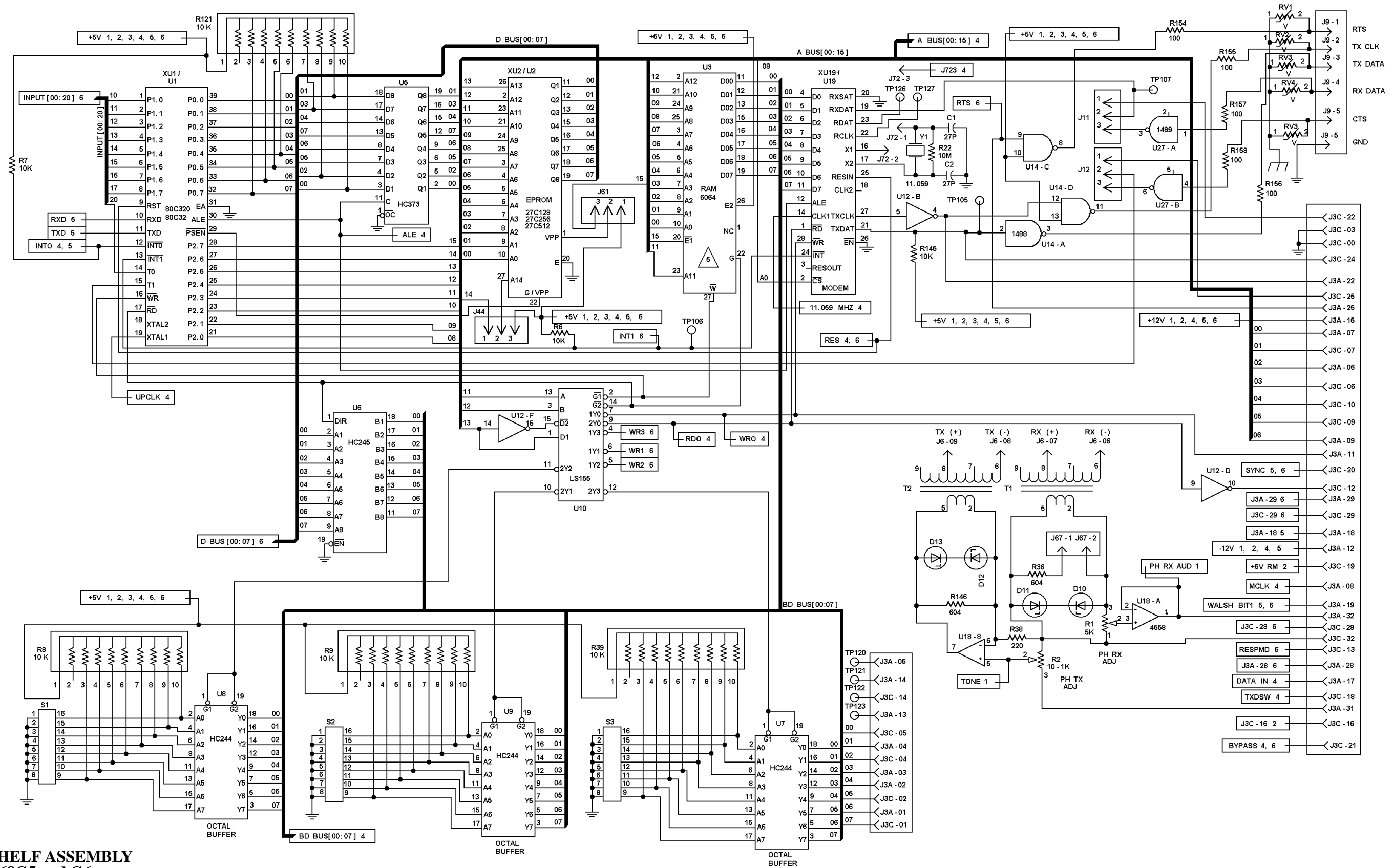

**GETC SHELF ASSEMBLY
19D901868G5 and G6**

(188D6822, Sh. 3, Rev. 1)

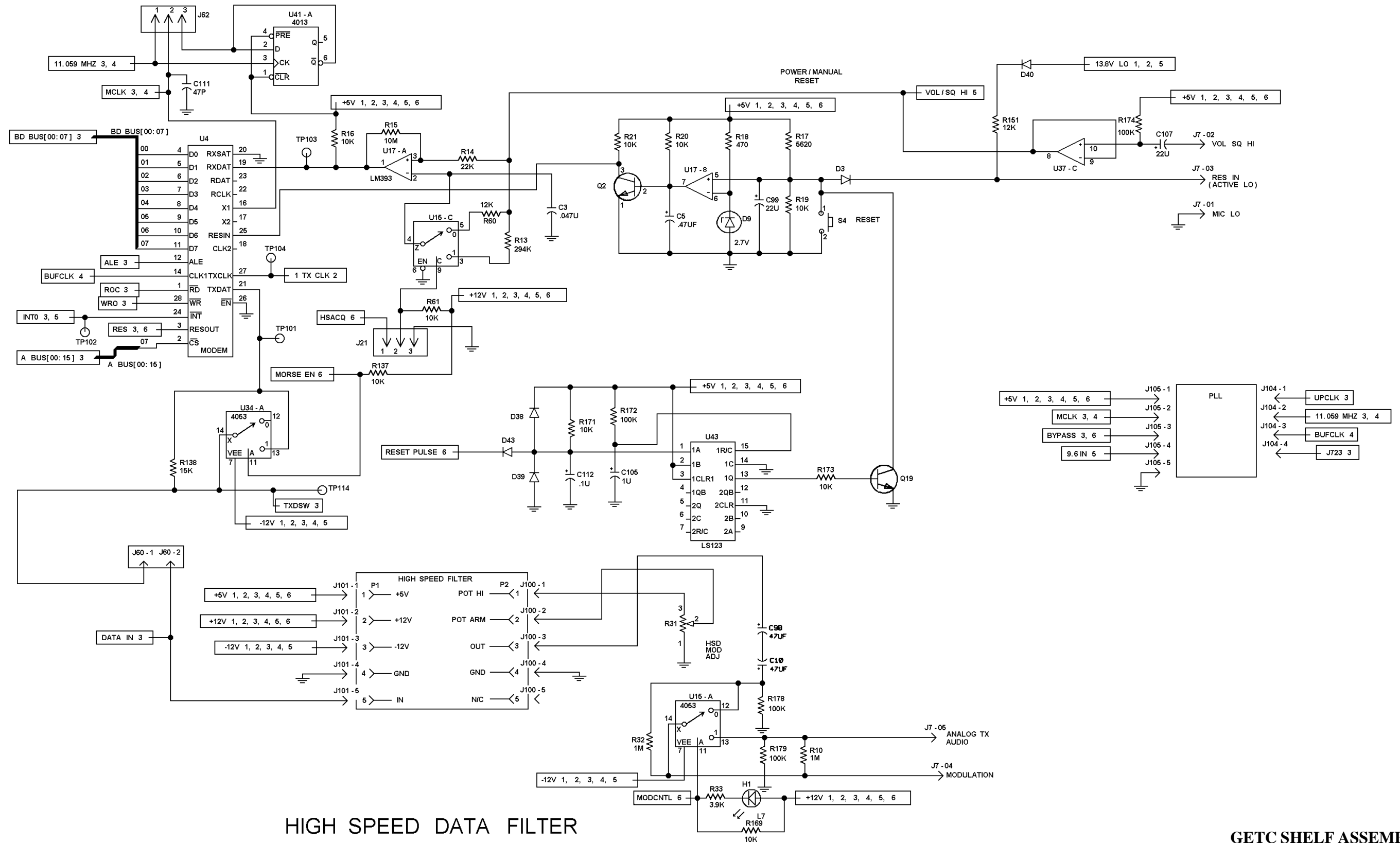

HIGH SPEED DATA FILTER

GETC SHELF ASSEMBLY
19D901868G5 and G6
(188D6822, Sh. 4, Rev. 1)

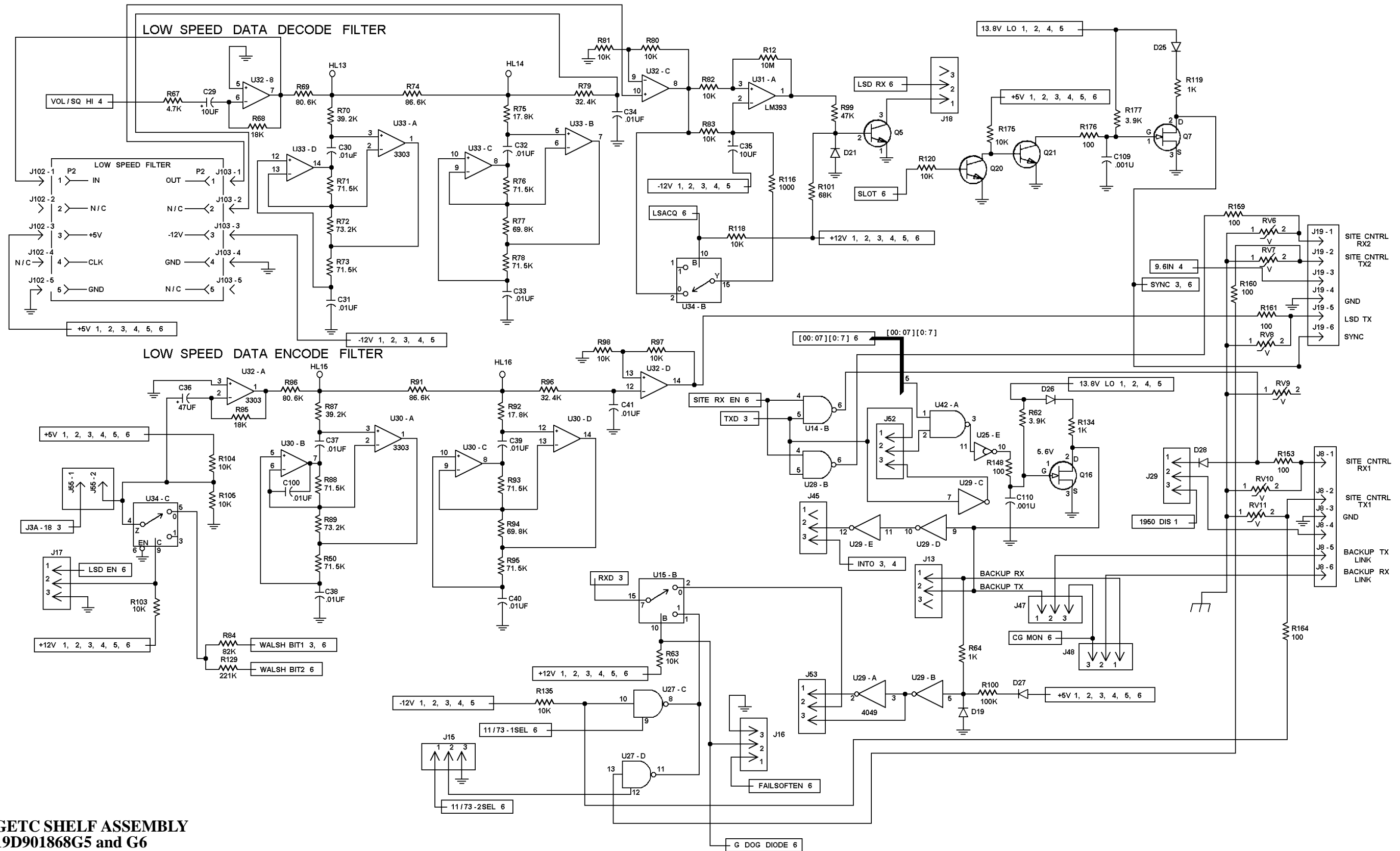

GETC SHELF ASSEMBLY
19D901868G5 and G6

(188D6822, Sh. 5, Rev. 1)

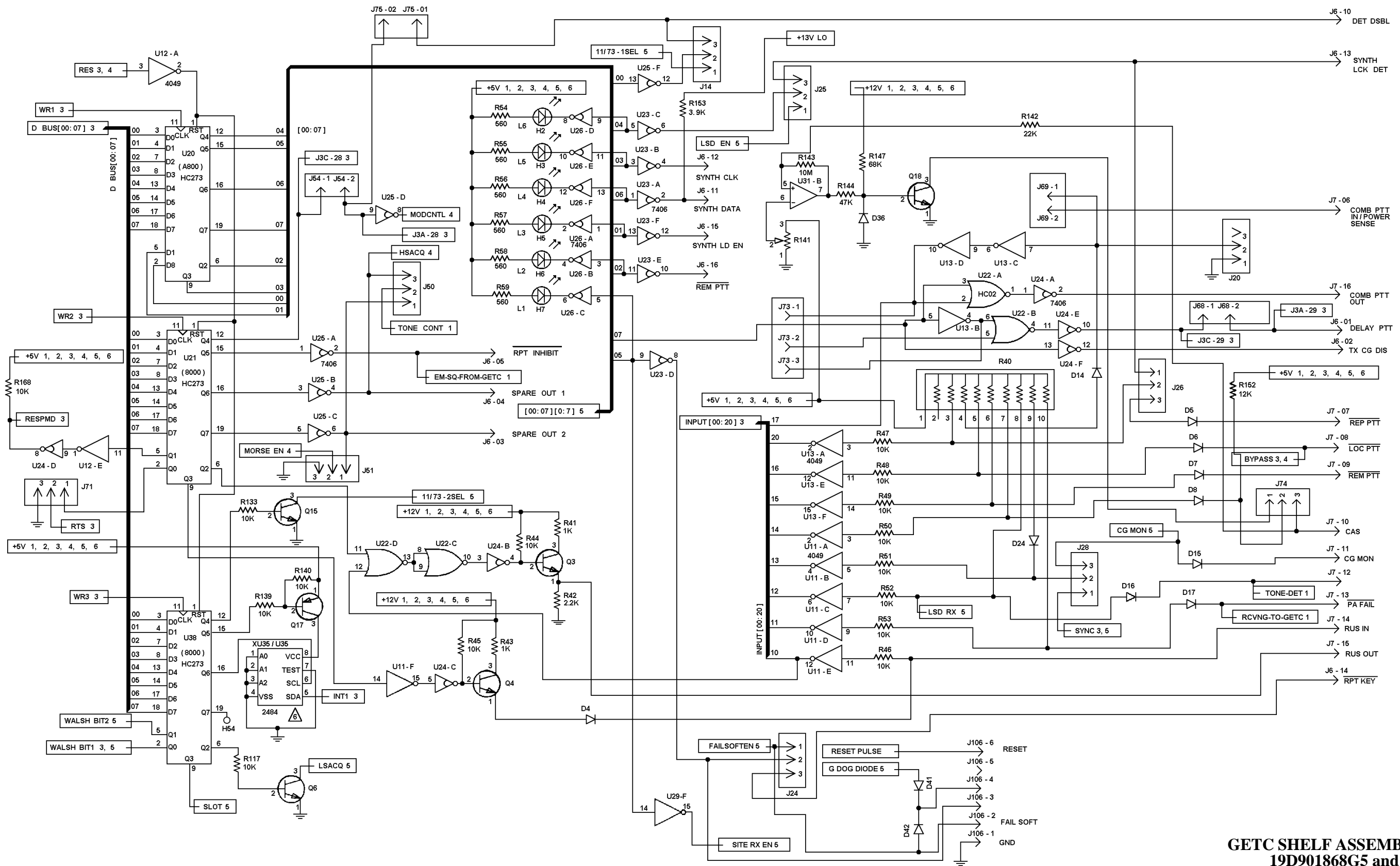

GETC SHELF ASSEMBLY
19D901868G5 and G6

(188D6822, Sh. 6, Rev. 1)

Ericsson Inc.
Private Radio Systems
Mountain View Road
Lynchburg, Virginia 24502
1-800-528-7711 (Outside USA, 804-528-7711)