

LBI-4650S

Maintenance Manual

**REMOTE KEYING SYSTEM
(OPTIONS 5264 & 5265)**

**TONE FAILURE BOARD
(OPTION 5269)
USED WITH VOTING SELECTOR
PANEL**

TABLE OF CONTENTS

	<u>Page</u>
SPECIFICATIONS	1
DESCRIPTION	2
TELEPHONE LINE CHARACTERISTICS	2
INSTALLATION	4
ADJUSTMENT	4
MAINTENANCE	4
CIRCUIT ANALYSIS	4
OUTLINE DIAGRAMS	
REMOTE KEYING CONTROL SHELF 19D416725G2 & G4	7
CONTROL SHELF BACK PLANE 19C320833G1 & G2	8
KEYING LOGIC, DC CONTROL BOARD, AND TRANSMIT DETECTOR BOARD	9
TONE CONTROL BOARD 19D417417G1	10
TONE CONTROL BOARD 19D417417G1 (USED IN EALIER MODELS)	11
AUDIO BOARD 19D417432G1	12
TONE FAILURE BOARD 19A130122G1	13
POWER SUPPLY MODULE 19D417430G1	14
RECTIFIER BOARD A1 19D417428G1	15
CONTROL SHELF 19D416725G2	16
SCHEMATIC DIAGRAMS	
KEYING LOGIC & DC CONTROL BOARD 19D417452G2	18

TRANSMIT DETECTOR BOARD (19D417263G1)	20
TRANSMIT DETECTOR BOARD (19D417263G1)	21
TONE CONTROL BOARD 19D417417G1	22
TONE CONTROL BOARD 19D417417G1 (USED IN EALIER MODELS)	26
AUDIO BOARD 19D417432G1	28
TONE FAILURE BOARD 19A130122G1	31
POWER SUPPLY MODULE 19D417430G1	33
KEYING LOGIC & DC CONTROL BOARD 19D417452G1	40
BLOCK DIAGRAMS	35
DC REMOTE KEYING SYSTEM	35
TONE REMOTE KEYING SYSTEM	36
INTERCONNECTION DIAGRAMS	
REMOTE KEYING CONTROL SHELF 19D416725G4	17
TONE REMOTE CONTROL HARNESS 19A130010G4	37
SERVICE SHEET	38
KEYING LOGIC & DC CONTROL BOARD 19D417452G1	39

SPECIFICATIONS*

AUDIO OUTPUT LEVEL	+11 dBm (max.)
KEYING VOLTAGE	+10 Volts
DC KEYING OUTPUT	+6.0 mA ±0.5 mA
TONE KEYING OUTPUT	2175 Hz @ +10 dBm +0-20dB (125 ms) 1950 Hz @ 10dB lower (40 ms) 2175 Hz @30dB below initial burst for duration of transmission.
TONE FAILURE BOARD FREQUENCY	1200 Hz ±5.0 Hz
TONE FAILURE DURATION	Adjustable 50 ms to 1.0 second
TONE FAILURE REPETITION RATE	Adjustable 5 seconds to 30 seconds
DIMENSIONS (HxWxD)	5-1/4" x 19" x 7-1/2"

* These specifications are intended primarily for the use of the serviceman. Refer to the appropriate Specification Sheet for the complete specifications.

NOTICE

Repairs to this equipment should be made only by an authorized service technician or facility designated by the supplier. Any repairs, alterations or substitution of recommended parts made by the user to this equipment not approved by the manufacturer could void the user's authority to operate the equipment in addition to the manufacturer's warranty.

NOTICE

The software contained in this device is copyrighted by Com-Net Ericsson Critical Radio Systems, Inc. Unpublished rights are reserved under the copyright laws of the United States.

This manual is published by **Com-Net Ericsson Critical Radio Systems, Inc.** without any warranty. Improvements and changes to this manual necessitated by typographical errors, inaccuracies of current information, or improvements to programs and/or equipment, may be made by **Com-Net Ericsson Critical Radio Systems, Inc.** at any time and without notice. Such changes will be incorporated into new editions of this manual. No part of this manual may be reproduced or transmitted in any form or by any means, electronic or mechanical, including photocopying and recording, for any purpose, without the express written permission of **Com-Net Ericsson Critical Radio Systems, Inc.**

WARNING

No one should be permitted to handle any portion of the equipment that is supplied with high voltage; or to connect any external apparatus to the units while the units are supplied with power. **KEEP AWAY FROM LIVE CIRCUITS!**

DESCRIPTION

The Remote Keying System and Tone Failure Board are used with the Voting Selector Panel to provide keying current or tones on the telephone pair to a remote/repeater station whenever the voting selector selects a received signal. The remote failure circuit provides periodic "beeps" every thirty seconds to indicate a failure in the voting system.

Two options are available for remote keying. Option 5264 is used in DC remote control systems and Option 5265 is used in tone remote control systems. The circuits for these options are provided on plug-in modules which are housed in a 19-inch 3-rack unit shelf. The modules plug into a backplane by means of GEAPS connectors.

The DC remote keying system consists of a power supply module, a keying logic and DC control module and transmit detector module. The tone remote keying system utilizes those modules used in the DC system, plus audio and tone control modules. The Tone Failure (option 5269) module is accommodated on the same shelf at the J2506 position.

Four wire audio is required at the station as well as at the MASTR Controller when used in the system. A line pair is connected from the receiver audio output at the station directly to the Voting Selector. In the DC control version, audio is fed from the Voting Selector line driver directly to the line. In the tone control version, audio is coupled from the Voting Selector to the Audio Module and then to the line.

A delaying capacitor is added to the Repeater Control Board in the Station Control Shelf to prevent the station from keying for approximately 200 milliseconds when the receiver squelch is opened. This allows the remote keying system to key the station as though it were a remote control. Remote priority then overrides the repeat keying. If the remote keying should fail, the repeater will then automatically key (after the 200 ms delay) providing emergency backup to the remote keying system if local receiver is un-squelched.

The Audio Board in the Station Control Shelf is modified to mute the audio coupler path to allow receiver muting without killing the receive line driver. This is necessary when the station receiver votes which would then mute its own signal.

A capacitor is added between terminals TB1101-9 & 13 of the MASTR Controller (Modification Kit 19A130057) in the DC control version of the remote keying system to isolate the receiver transformer (added by the 4-wire audio option) from the DC control voltage on the line.

TELEPHONE LINE CHARACTERISTICS

As a result of propagation conditions, ambient noise levels, space limitations or other conditions, the most advantageous location for the dispatcher may not be the best location to originate or receive transmissions. The Remote Control permits the dispatcher to transmit, receive, select transmitter and receiver frequencies, etc., over telephone lines. Control currents applied to the telephone lines from the controller are normally translated into the desired operation at the base station by the remote control panel.

The key link in a remote control installation is the telephone pair between the Controller and the base station. To obtain the most satisfactory service over this link, some general knowledge of the capabilities of such lines is required.

A telephone pair is simply a pair of wires, normally ranging from AWG #19 to AWG #26 in size. These wires, furnished by the local telephone company, pass through over-head cables, underground cables, through junction points, and switchboards. To the user, however, they may be considered a simple pair of wires. Equipment that is designed to operate with such a pair should have nominal impedance of 600 ohms. A telephone pair will normally have a maximum length of about 12 miles before amplification is added by the telephone company to make up for line losses. There is an inherent loss in any telephone line installation due to the series inductance and resistance and the shunt capacitance of the wires. This loss is a direct function of the length of the line, and varies with the wire size used. As an example, with AWG #19 wire, a distance of six miles may be covered before one-half the input voltage of a 1,000 Hz tone is lost. With AWG #26 wire, only two and one-quarter miles may be covered before one-half the input voltage is lost. Line losses as high as 30 dB can be tolerated in operating a transmitter from the Remote but such high losses should be avoided whenever possible. Although the telephone pair is fairly well balanced, some noise will be induced into the line, especially if an unshielded run has to be made in a fluorescent-lighted building.

The DC resistance of any telephone pair will affect the control circuits between the Controller and the base stations. Current regulators incorporated in the Remote Control minimize these variations after initial adjustment. The Remote operates with a total control line loop resistance as great as 11,000 ohms. There is a possibility, however, that stray currents, due to leakage, noise, faults, earth currents, etc., may cause faulty operation.

Three types of telephone line connections are commonly used. Before choosing one of these types, consider the cost

METHOD	DESCRIPTION	ADVANTAGES OR DISADVANTAGES
1	One metallic pair: for both audio and control voltages with control voltage from line to line.	Economical; dependable where earth currents may be large; slight keying clicks will be heard in paralleled Remote Control Units. In most applications, preferred over Method No. 2.
2	One metallic pair: for both audio and control voltages with control voltages from line to ground.	Economical; earth ground currents may result in interference with control functions; keying clicks minimized. Good earth to ground required at station and all control points.
3	Two telephone pairs; one for audio voltage one for control voltage (metallic pair).	Provides best performance; keying clicks will not be heard. Requires 2 pair.

and performance of each, as one type may be available at a much lower rate. Also, some telephone companies offer no choice. The above chart contains information to assist in selecting the control method and type of telephone line to be used in DC control applications.

Proper Grounding Practices (Method 2)

The telephone company specifies that their customer's equipment signal ground should be made using the proper connection to a ground electrode such as a metallic cold water pipe. The ground connection should be short, straight and a continuous piece of wire. Attention should be given to providing the lowest possible resistance at the connection at each end of the ground wire.

When option line surge protection devices are provided in the customer equipment, it is imperative that the good earth ground be used. If the telephone company also provides protective devices, the customer provided device earth ground connections should be located close to the telephone company earth ground connections but should not use the same ground clamp that the telephone company uses.

If a good earth ground as described above cannot be obtained, Method 2 should not be used. Also, the addition of surge protective devices are of little value without the proper earth ground.

Four Wire Audio

In remote control two-way radio systems where customer-owned multiplex/microwave systems are utilized, or where leased lines obtained from the local telephone company do not utilize hybrids in the transmission path, 4-wire audio operation may be required. The 4-wire audio system provides separate connections for the receive audio path and the transmit audio path. See Figure 2.

The 4-Wire Audio Kit (Option 9507) consists of a separate transformer mounted to the Mother Board with special connections to be made to TB1201. Refer to the Installation Instructions for Option 9507.

E & Signaling

E & M lead signaling systems derive their name from certain historical designations of the signaling leads on circuit drawings. An "M" lead is associated with the transmit function while the "E" lead is associated with the receive function. In two-way radio systems with remote control, E & M Signaling may be the only type of supervision offered by the available carrier circuits.

Generally both 4-Wire Audio and E & M Signaling options are used to interface between the radio and carrier systems. However, 2-Wire Audio may be used in the two-way radio portion of the control system if hybrids are installed to provide transition between the 2-wire and 4-wire connections. Usually the E & M Signaling is separated from the audio (separate line) in both 2-wire and 4-wire installation.

Figure 3 illustrates a typical interface between a two-way radio system and a multiplex/microwave system. The Remote Control Console and Base Station are equipped with the E & M Signaling Option and a 4-Wire Audio Option. The console provides a regulated -48 VDC output (or -24 VDC with minor modifications) to the "M" lead when the TRANSMIT switch is pressed. This -48 volts activates a tone encoder (usually 3825 Hertz) in the multiplex rack. The tone encoder modulates the carrier frequency which is transmitted over the microwave link.

At the station end of the microwave link, the signal is demodulated and the 3825 Hertz tone operates a tone decoder in the multiplex rack. The output of the decoder results in a contact closure to provide transmitter keying in the Remote Control Base Station.

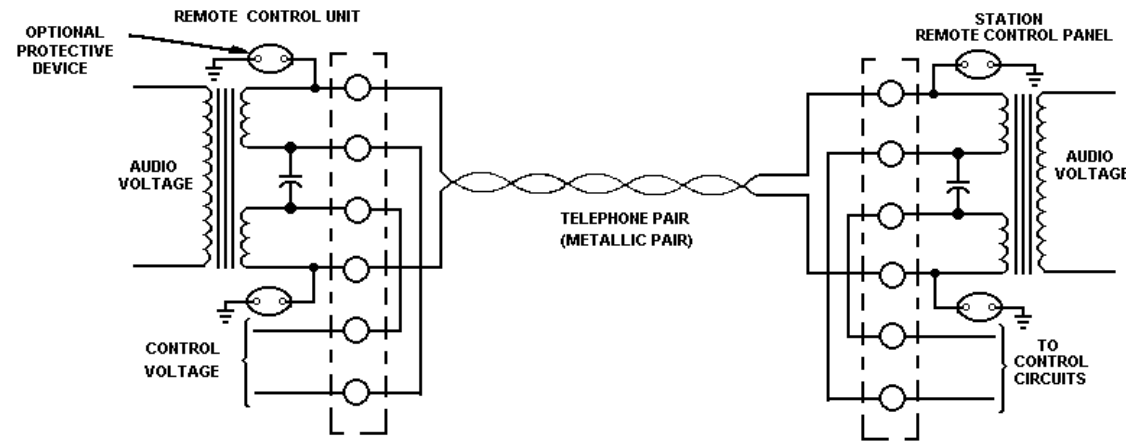

METHOD 1 - SINGLE TELEPHONE PAIR WITH CONTROL LINE TO LINE

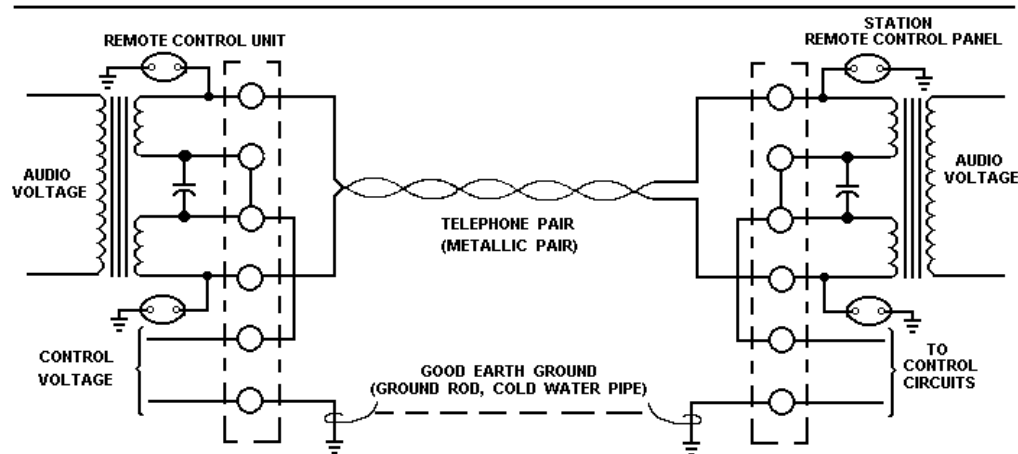

METHOD 2 - SINGLE TELEPHONE PAIR WITH CONTROL BETWEEN CENTER TAP AND GROUND

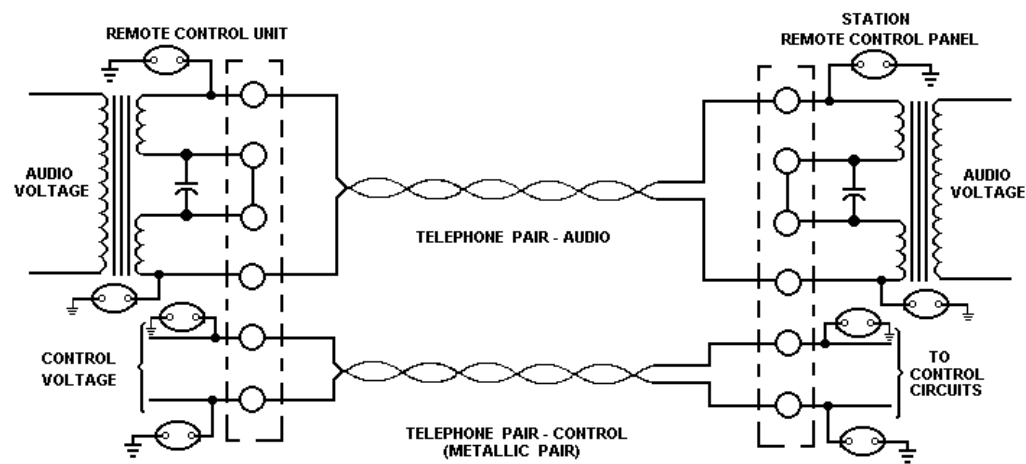

METHOD 3 - SEPARATE CONTROL AND AUDIO PAIRS

Figure 1 - Telephone Line Connections

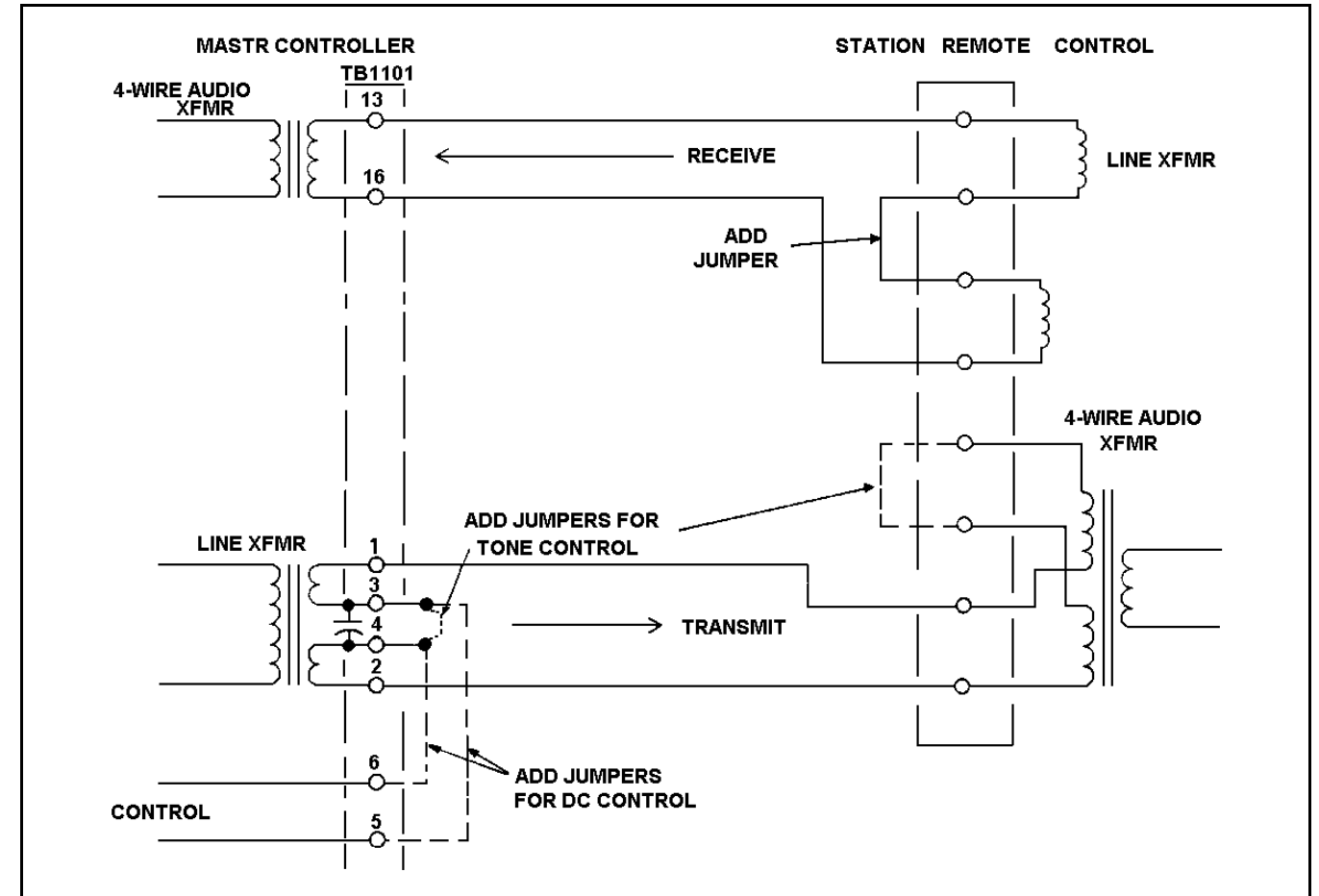

Figure 2 - Typical 4-Wire Audio Installation

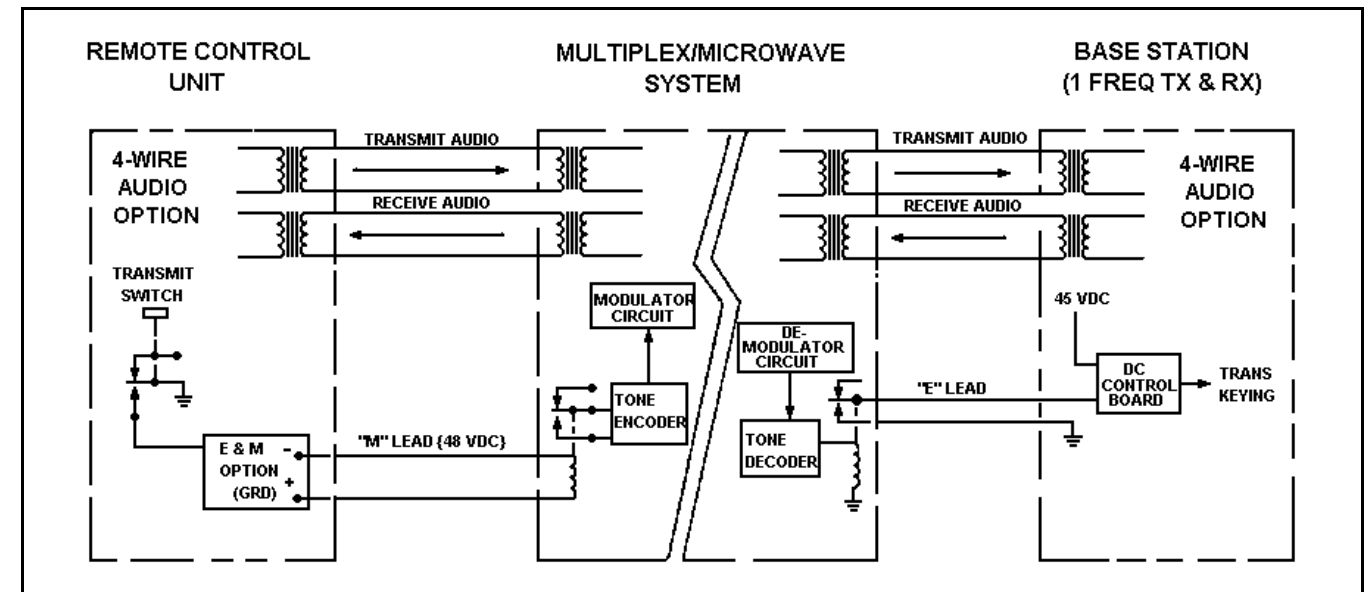

Figure 3 - Typical Application of E & M Signaling

INSTALLATION

The Remote Keying System control shelf is mounted in the Voting Selector cabinet using #12-24 x 1/2 inch screws. The shelf is located either directly below the Voting Selector Panel or the 19C320687 Power Converter Panel if used. The power cable to the shelf is supplied with a three-prong plug which connects to the 19B226175G1 receptacle mounted on the cabinet.

An interconnect harness (19A130010G4) is used in the tone control version of the remote keying shelf. Interconnect harness (19A130010G3) is required for the DC version. The telephone pair between the Remote Keying shelf and the MASTR Controller is connected to TB2501-7 & 10 on the keying shelf backplane.

The Remote Keying Shelf is modified in the DC control version by removing the jumper between hole 3 and hole 4 on the backplane of the Control Shelf. The system power supply is modified in the tone control version by removing the jumper between hole 14 and hole 15 on the power supply printed board.

ADJUSTMENT

DC Control (Option 5264)

Any necessary adjustments should be made according to the following procedure:

WARNING

Disconnect the **RCVNG** lead from the Voter on TB2502-5 before following this procedure. Failure to do so could result in damage to the Voter.

1. Connect a DC Voltmeter to TB2502-9 on the backplane of the Remote Keying Shelf.
2. Momentarily jumper TB2502-1 to TB2502-5 and observe the time the meter remains at less than 0.5 Volts. The time should be approximately 5 seconds.
3. If necessary adjust the DROP-OUT DELAY TIMER control R14 on the Transmit Logic Board for the desired time.
4. Connect jumper between TB2502-1 and TB2502-5. Observe the time that the meter reads less than 0.5 Volts.

5. If necessary, adjust the 3-MINUTE LIMIT TIMER control R3 on the Transmit Logic Board for the desired time. With R3 at minimum, the time should be less than two minutes. With R3 at maximum, the time should be greater than three minutes.

Reconnect the **RCVNG** lead to TB2502-5. If it becomes necessary to readjust timers, be sure to disconnect this lead.

6. Connect a DC millimeter in series with the control pair (positive lead of meter to TB2501-6).
7. Ground TB2502-9 and measure +6.3 mA on the meter. If necessary, adjust R31 on the Transmit Logic Board to obtain a reading of +6.3 mA.

Tone Control (Option 5265)

The audio line output was set at the factory for a reading of 2.7 Volts RMS (+11 dBm). If adjustment is required, it should be made according to the following procedure:

WARNING

Disconnect the **RCVNG** lead from the Voter on TB2502-5 before following this procedure. Failure to do so could result in damage to the Voter.

1. Connect an AC-VTVM across the audio output pair (TB2501-7 & 10).
2. Turn MIKE GAIN control R28 on Audio Board fully counterclockwise.
3. Apply a 1000 Hz, 40-millivolt signal to TB2502-3 & 4. Use a 0.22 mfd capacitor in signal generator lead with + side of capacitor connected to TB2502-4.
4. Ground TB2502-9 and adjust LINE OUTPUT control R54 on the Audio Board for 2.7 Volts RMS.
5. Reduce input to 25 mV RMS and adjust R28 for a level 1 dB below the 2.7 V RMS reference. Repeat this procedure until a 1 dB change in output results from an input change from 40 mV to 25 mV RMS.
6. Remove the ground at TB2502-9. Connect ground to TP8 on the Tone Control Board. Reground TB2502-9. Adjust the TONE OUTPUT LEVEL control R18 for a reading of 2.7 Volts RMS on the VTVM if necessary.

7. Remove the ground from TP8 and TB2502-9. Connect a DC Voltmeter to TB2502-9.
8. Momentarily jumper TB2502-1 to TB2502-5 and observe the time the meter remains at less than 0.5 Volts. The time should be approximately 5 seconds.
9. If necessary, adjust the DROP-OUT DELAY TIMER control R14 on the Transmit Logic Board for the desired time.
10. Connect jumper between TB2502-1 and TB2502-5. Observe the time that the meter reads less than 0.5 Volts.
11. If necessary, adjust the 3-MINUTE LIMIT TIMER Control R3 on the Transmit Logic Board for the desired time. With R3 at minimum, the time should be less than two minutes. With R3 at maximum, the time should be greater than three minutes.

Reconnect the **RCVNG** lead to TB2502-5. If it becomes necessary to readjust timers, be sure to disconnect this lead.

NOTE

Selector audio output at TB8-7 & 10 must be set to 100 mV RMS +10 mV when operating into Remote Keying Panel.

12. Set LINE IN Control R1 on Audio Board to its maximum position.
13. Adjust audio signal generator for 120 mV RMS at 1000 Hertz.
14. Measure the VOL HI audio level at PA1-9 and record.
15. Reduce generator output to 80 mV rms. Adjust R1 until the ac vtm reads 1 dB below the reference level recorded above (VOL HI P1A-9). Repeat this procedure until a 1 dB change in output results from an input change from 120 mV rms to 80 mV rms.

Tone Failure Board (Option 5269)

1. Ground TB2502-6 to simulate a failure from the Voting Selector Panel.
2. Measure the level of the tone bursts at TB2501-7 and TB2501-10. These bursts should be 2.7 Volts RMS

(+11 dBm) at 1200 Hz \pm 5.0 Hz. If necessary, adjust R7 on the Tone Failure Board to obtain this level.

3. Adjust R42 on the Tone Failure Board to obtain the desired tone burst period. This period is adjustable from 50 milliseconds to 1.0 second.
4. Adjust R40 on the Tone Failure Board to obtain the desired tone burst repetition rate. This rate is adjustable from 5 seconds to 30 seconds.

MAINTENANCE

The Remote Keying System is designed for ease of servicing and minimum maintenance. All circuit modules plug into cardedge connectors on the backplane and can be easily removed for routine inspection and maintenance. An Extender Board is supplied for servicing any of the modules out of the shelf while maintaining circuit connections.

The Tone Control Board is provided with test points for checking the proper tone selection and timing. A counter may be connected to TP4 to check the oscillator. The oscillator should be idling at 2175 Hz at a level between 150 to 200 mV.

Connecting a scope to TP8 on the Tone Control Board will indicate the timing of the Secur-it Tone One-Shot when PTT ground is selected. The waveform should indicate a high (2.4 VDC or more) until the beginning of the one-shot timing sequence, drop to a low of 0.4 VDC or less for a period of 125 milliseconds \pm 20% and then return to high.

Connecting the scope to TP2 will show the Function-Tone One-Shot timing waveform when PTT ground is applied to the board. The waveform should indicate a high (2.4 VDC or more) for the 125 millisecond Secur-it tone period and then switch to a low (0.4 VDC or less) for a period of 40 milliseconds and then return to high.

CIRCUIT ANALYSIS

DC Control Keying

When a receiver in the Remote Keying System unscquelches, the Voting Selector COS applies +10 Volts DC to TB2502-5 of the Remote Keying Shelf. This +10 Volts is then applied to the Transmit Logic and DC Control module at J2502-B3. This voltage operates the 3-Minute Limit Timer.

The 3-Minute Limit Timer is required by the FCC in certain repeater applications to automatically shut off the transmitter after a maximum of three minutes continuous operation.

The Timer prevents the transmitter from accidentally "locking on" and tying up the channel.

The switching circuits of the Timer consists of a Schmitt Trigger (Q4 and Q6) and a DC switch (Q5). Q4 is normally off so that Q6 is allowed to conduct, keeping Q5 turned on. Q1, VR2 and R2 are connected to form a constant current source providing a linear charging current for capacitor C1. Q2 and Q3 operate as a compound-connected emitter follower.

As C1 slowly charges up, the output voltage of the emitter follower rises proportionally. When the charge on C1 is large enough to cause approximately 1.5 Volts at the base of Q4, the transistor turns on. Turning on Q4 turns off Q6 and Q5. Turning off Q5 removes the +10 VDC to the Drop-Out Delay Timer.

When the receiver is squelched, C1 discharges rapidly through the collector base junction of Q1 and R10 to reset the timing circuit. When permitted by FCC regulations, the Timer can be set for a timing cycle of 2.5 to 3.5 minutes by the LIMIT TIMER ADJUST control R3.

The Drop-Out Delay Timer decreases the number of transmitter "ON-OFF" cycles by keeping the transmitter keyed for a predetermined delay period after the receiver squelches. The delay period can be set for 0.5 to 5 seconds. Unsquelching the receiver at any time during the delay period keeps the transmitter operating without interruption. After the delay time lapses and no signal is applied to the receiver, the transmitter keying circuit is de-energized and the transmitter turns off.

When Q5 on the 3-Minute Limit Timer operates, Q7 turns on. Turning the stage on rapidly discharges capacitor C4 and switches the Schmitt Trigger so that Q8 is off and Q9 is on. This turns on Q10 and applies 10 Volts to the base of Q11. Turning on Q11 operates Q12, applying ground to the cathode of the Light Emitting Diode on U1. The light from the LED is detected by the photodetector on U1, turning on Q17 and Q1 on A2. Conduction of these transistors connects the high voltage across VR1, CR8 and CR9 to the control pair (terminals B8 and B9), providing the +6.0 mA remote keying control current.

If a ground is applied to the INHIBIT lead (B6), CR1 will be forward biased, turning off Q13. Q14 is also turned off. This results in Q15 and Q16 operating, applying a ground to the base of Q12 and preventing the keying circuit from operating.

When Q15 is operated, Q18 is turned on. Conduction of Q18 applies a ground to the mute terminal B14 to mute the selected audio.

If a receiver has voted and Q12 is conducting, CR4 is forward biased. This prevents Q15 from conducting and, if a ground is applied to the INHIBIT lead under this condition, the keying circuit will not be inhibited. The inhibit circuit is required in remote/repeat systems to prevent the Voting Selector from keying over the remote control.

The control current is sampled at the Transmit Detector Board at terminals A8 and A10. Voltage dividers R33 and R34 apply the sampled voltage to the base of Q15, turning Q15 on. Conduction of Q15 forward biases CR5, allowing the 250 kHz oscillator (Q16) output through to transformer T1. This turns Q14 on. When Q14 is conducting, its collector voltage drops to ground potential. This ground is connected to terminal A1, completing the ground path for the INHIBIT lead.

Tone Control Keying

In the tone remote keying system, the Transmit Logic Board functions in the same manner as described for the DC system except that the DC control high voltage input is disabled at the power supply. When Q12 on the Transmit Logic Board conducts, ground is applied to the PTT lead at B2.

The PTT ground is then connected to terminal All on the Tone Control Board. The tone oscillator is located on this board. The oscillator consists of integrated circuit U1 and the associated frequency-determining circuits. Variable resistor R54 provides a means of adjusting the oscillator to its center frequency. By the logical selection of the proper frequency-determining resistor, the nominal frequency of the oscillator can be changed as required.

The PTT ground is applied to the base of Q14. This transistor is turned off, turning Q15 on. The low at the collector of Q15 (TP7) is inverted by U6C, turning on PTT latch Q17. This transistor remains on for the duration of the tone control sequence. Q14-Q15 senses the level of the PTT line above ground and maintains the level within 0.6 volts to insure proper audio inhibit.

The low at the output of Q15 is also applied to U2A-1. This low is inverted by NOR gate U2A and inverted again by U4A. The resultant low at pin 2 of U4A discharges C12 and operates the Secur-it Tone One-Shot U3A-U4B. The low output at pin 4 of U4B turns off Q7. The high at the collector of Q7 is inverted by U4C and the resultant low at the output of U4C (TP8) is applied to NOR gate U2B (Tone Inhibit). The high output at U2B-8 (TP10) is inverted at U6E and the resultant low turns off Tone Gate Q3.

Transistor Q9 is normally conducting, connecting R28 into the frequency-determining network of the tone oscillator. Turning off Tone Gate Q3 thus allows the 2175 Hz Secur-it tone through to the tone amplifiers Q4-Q5. The amplified tone

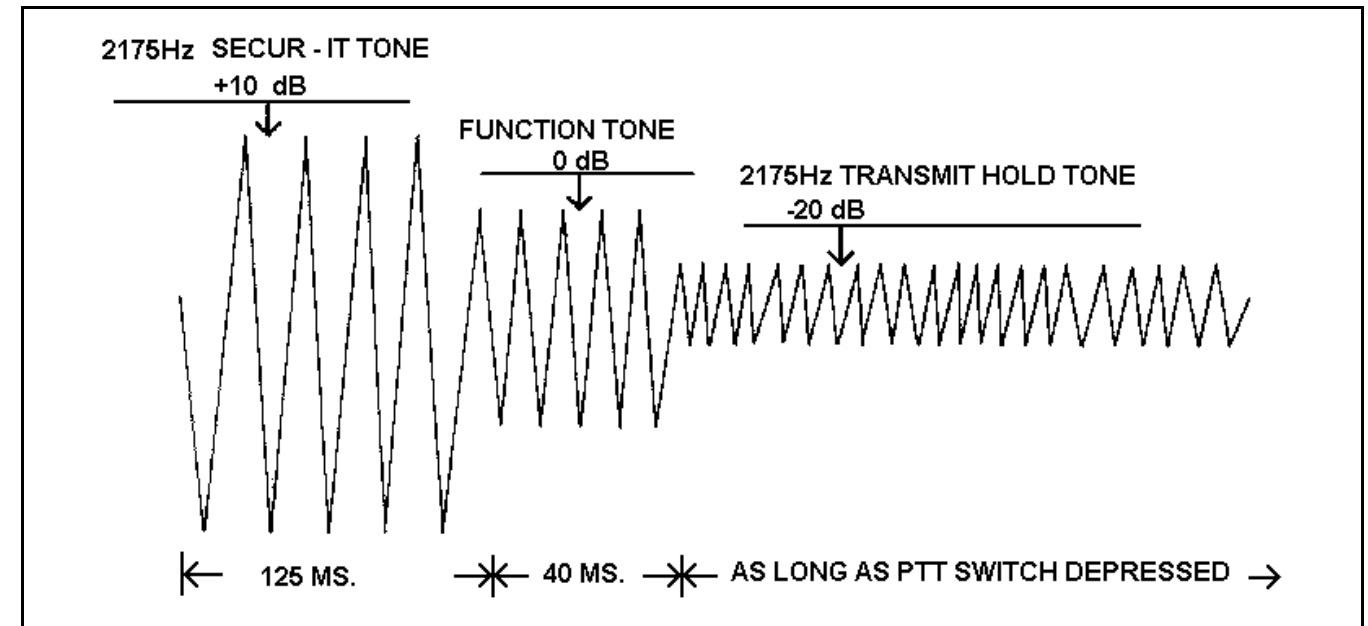

Figure 4 - Tone Control Sequence

is connected through TONE LEVEL ADJUST potentiometer R18 to the tone output terminal A14. The low output of U4C is also inverted by U3D and again by U6D. The resultant low turns off the 30-dB attenuator Q2. (See Figure 4).

The Secur-it Tone One-Shot remains in the on condition for a period of 125 milliseconds, determined by the RC time constant of R22 and C13. When the one-shot returns to its normal state, the high at pin 4 of U4B turns Q7 on. The low at the collector of Q7 is inverted by U4C and inverted again by U4D. Capacitor C14 is discharged, turning on the Function Tone One-Shot U3B-U4E. The low output at U4E-10 turns off Q8 and the high at the collector of Q8 is inverted by U4F, turning off Q9. The low at U4F-12(TP2) is applied to U2B-9, keeping Tone Gate Q3 open.

The high output of U3B is connected to the base of Q1 (10-dB attenuator), turning the transistor on. Thus the selected function tone is transmitted at a level 10 dB below the Secur-it tone level. The high output of U3D (when either of the tone control one-shots is active) is applied to the AUDIO INHIBIT lead A1, preventing audio output from the Audio Board during tone transmission. The output of U3D also continues to hold the 30-dB attenuator off. The high output of U2B turns on Q16, enabling the Audio Board to transmit the tones.

The high output of U3B is also connected to U7B-3. The resultant low output at U7B-6 is inverted by U6F, turning on Q13 and connecting R29 into the frequency-determining network of the tone oscillator. Thus the function tone of 1950 Hz is transmitted.

At the end of the 40 ms function tone period, a high is applied to U3D at pin 12. The low output of U3D is inverted by U6D and the resultant high turns the 30-dB attenuator (Q2) back on. Q9 is also turned back on, transmitting the 2175 Hz tone at a level 30 dB below its Secur-it tone level as long as the PTT ground is maintained. This keeps the base station transmitter keyed while the message is being sent.

Audio from the Voting Selector is coupled to terminals D1 and D14 of the Audio Board. The audio is then connected to the MIKE IN ADJUST control R28 where the proper audio level is set for the Compressor Amplifier. This amplifier consists of gain control stage Q10, high gain audio amplifiers Q11 through Q14 and DC amplifier Q15.

When audio is applied to the compressor amplifier, R29 and the AC impedance of Q10 act as a voltage divider for the AC input signal. The output of Q10 is amplified by a four-stage, direct-coupled amplifier (Q11 through Q14). Both AC and DC feedback in the amplifier circuit provides for stable operation.

A portion of the amplified output is fed through LINE OUT ADJUST Control R54 to the output line amplifier (Q17-Q18) and to the line transformer T1. The remaining portion of the audio output is rectified by detector CR9, filtered by C24 and amplified by DC current amplifier Q15. This DC output is fed back to the base of gain control transistor Q10.

The amount of DC feedback to the gain control stage determines the AC impedance of Q10. An increase in feedback reduces the AC impedance of Q10 which decreases the audio voltage to the AC amplifier, keeping the amplifier output constant. When the audio input decreases, the output of the AC amplifier starts to decrease, reducing the feedback to Q10. This raises the AC impedance of Q10 and increases the audio voltage to the AC amplifier, keeping the amplified output constant.

The PTT ground is also applied to the base of the receive audio switch Q8, turning the switch on. When Q8 is conducting, the feedback loop through R23 and CR4 increases the conduction of gain control stage Q1. This shorts the AC input to ground. The line input is thus cut off from the Speaker Compressor.

When transmit keying is originated at the MASTR Controller, the signal on the line is coupled from the line transformer to the LINE IN ADJUST control R1. With no ground applied to the PTT lead, Q8 is turned off and the gain control stage Q1 conduction is decreased, allowing the Speaker Compressor to function. Audio is coupled from the LINE IN ADJUST control to the Speaker Compressor. This amplifier functions in the same manner as described for the Line Compressor. Q2 through Q5 serve as the AC amplifiers; Q6 is the DC amplifier; Q1 is the gain control stage.

The output of the Speaker Compressor is connected to terminal A9 and then to A6 on the Transmit Detector Board. The audio input at A6 is connected to the active RC filter composed of C1-C6 and R1-R3. Variable resistor R3 allows adjustment of this filter to the 2175 Hz tone frequency. The 2175 Hz tone is amplified by high-gain amplifier Q1-Q4, with a feedback path from the emitter of Q5 to provide stability.

The 2175 Hz output is buffered by Q6, amplified at Q7 and passed to the tone selector CR1 and CR2. Q8 is normally conducting, clamping the amplifier output to prevent noise pulses from operating the XMIT LIGHT and INHIBIT path. When the 2175 Hz tone is present, it is rectified and turns off Q9. Q10 is also turned off. Q11 is turned on and conduction of Q11 turns off attenuator Q8 and also turns off Q12. Q13 is now turned on, operating the XMIT LIGHT and applying a ground to the INHIBIT lead.

The INHIBIT lead thus prevents a signal from the Voting Selector from completing the keying function, giving priority operation to the MASTR Controller.

Tone Failure Board (Option 5269)

The Tone Failure Board is used in the Remote Keying System when the Voting Selector and Remote Keying Shelf are located at a remote point from the MASTR Controller. The alarm circuit consists of a 1200 Hz oscillator which is operated by the Voting failure alarm signal. A highly asymmetrical astable multivibrator gates the alarm tone for a period of up to 1.0 second every 30 seconds. A line driver is provided which includes an isolation transformer for direct line bridging.

The failure alarm output of the Voting Selector is grounded when a receiver line fails. This ground is connected to the Failure Alarm Board on the remote keying shelf via terminal All. Q12 is turned on which turns Q13 on. Conduction of Q13 turns Q14 off. The high at the collector of Q14 then turns Q11 on and Q15 off. The high at the collector of Q15 operates Timer U1. The repetition rate of the Timer is adjusted by R40, and the duration of the timing period is adjusted by R42.

The 1200 Hertz alarm tone is generated by the Hartley oscillator composed of Q1, T1, C3, C4 and C12. The 1200 Hz output of the oscillator is amplified by Q2 and the tone level is adjusted by means of R7. The tone is then passed to amplifier Q3.

When the Timer is operated, Q16 is turned on which, in turn, operates the FET switch Q4. When Q4 is turned on, the 1200 Hz tone is passed to the line driver (Q5 and Q6). The line driver applies the tone to the line through isolation transformer T2.

Power Supply

The Power Supply Module is composed of the Rectifier Board A1, the Switch and Fuse Panel A2, the Power Transformer Board A3 and Regulator Heat Sink A4.

Closing the power switch S1 on the Switch and Fuse Panel applies 117 VAC to the power transformer. The AC line is fused by F1. The voltage is rectified at the Rectifier Board by full-wave bridge CR9-CR12 and filtered by C4, C5 and C6. The rectified DC is also applied to the Light Emitting Diode (LED) CR15, turning the diode on.

The DC voltage is applied to VR1, Q1 and Q3 and the resulting regulated 13.8 VDC is applied to terminal D5. The voltage is further regulated by VR2 and Q2 and the regulated 4.8 VDC is applied to terminal D4.

The 13.8 VDC is connected to the H.V. voltage doubler composed of Q1 and Q2. The square wave generated by Q1 and Q2 is applied to the doubler transformer and the high voltage developed in the secondary is rectified by CR4-CR7, filtered by C3 and applied to the H.V. terminals D1 and D14. The 13.8 VDC is also connected to the cathode of TRANSMIT LED CR14. When the PTT ground from the Transmit Logic Board is applied to terminal D10, CR14 is illuminated.

Battery standby is provided with the Power Supply. A diode (CR8) is connected in series with terminal D8. The diode is normally back biased, but if the supply voltage fails the diode will become forward biased and an auxiliary battery supply connected to TB2501-1 and 2 will be automatically substituted. When the supply voltage is restored, the diode is again back biased, automatically disconnecting the battery.

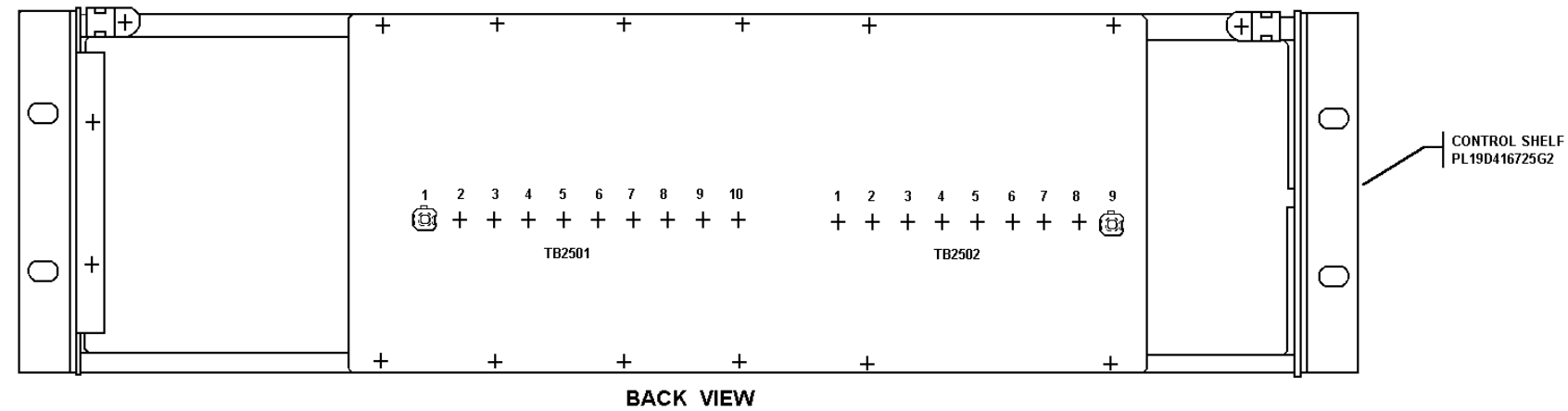
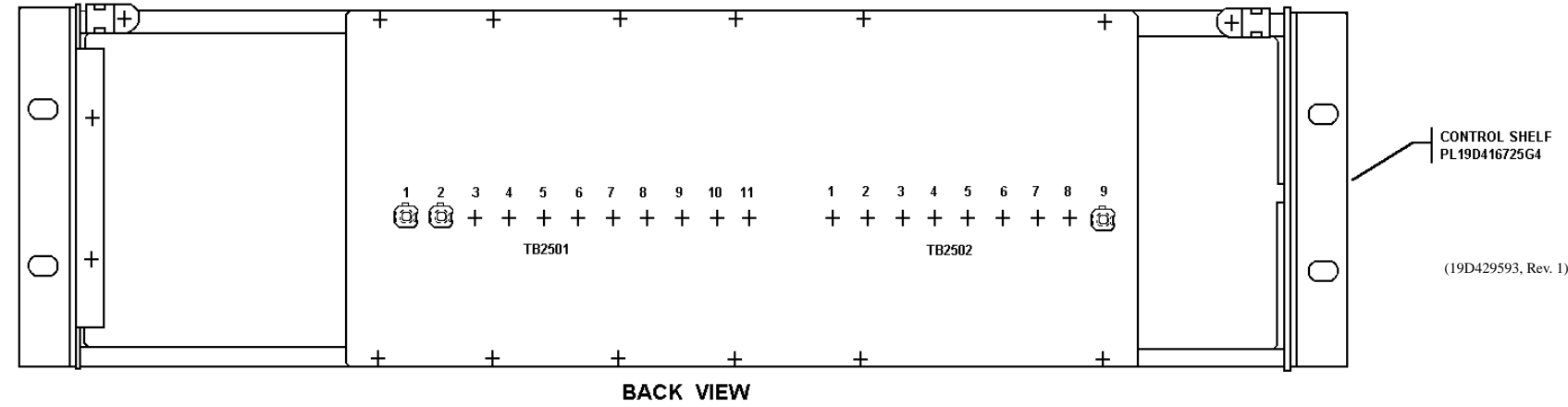

INSTRUCTIONS FOR MODIFICATION OF ALARM TONE BOARD (PL19A130122G1) FOR USE WITH REMOTE KEYING PANEL.

1. MOVE BEAD CHAIN CONNECTOR FROM J4 TO J5.
2. MOVE BEAD CHAIN CONNECTOR FROM J3 TO J2.
3. REMOVE AND DISCARD JUMPER BETWEEN H1 AND H2.
4. INSTALL DA JUMPER BETWEEN H2 AND H3.
5. REMOVE AND DISCARD R44.
6. REMOVE AND DISCARD R47.

NOTES:
1. USE ONLY WITH AC CONTROL SYSTEMS.

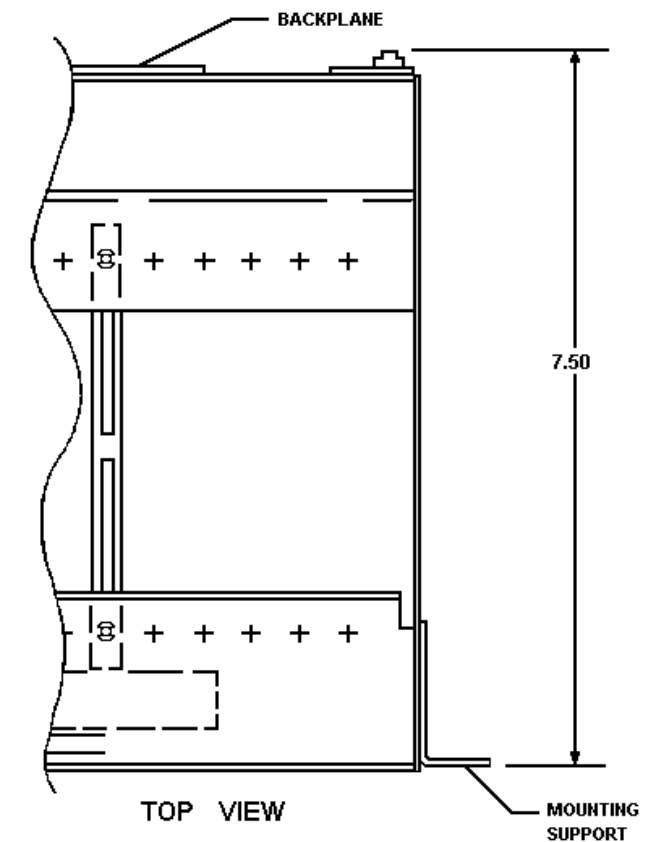
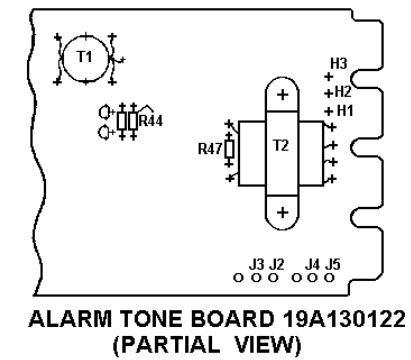
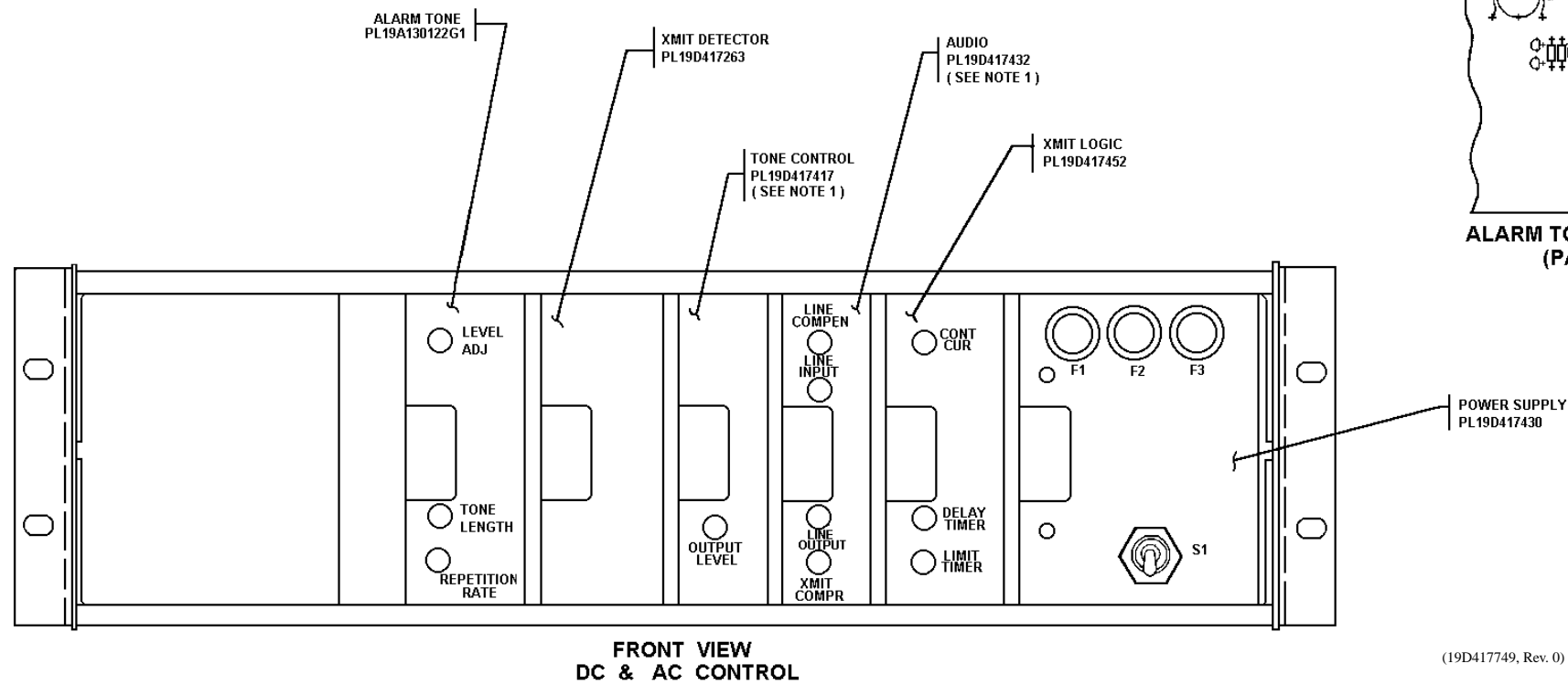

REMOTE KEYING CONTROL SHELF
19D416725G2 & G4

BACK PLANE BOARD 19C320833G1

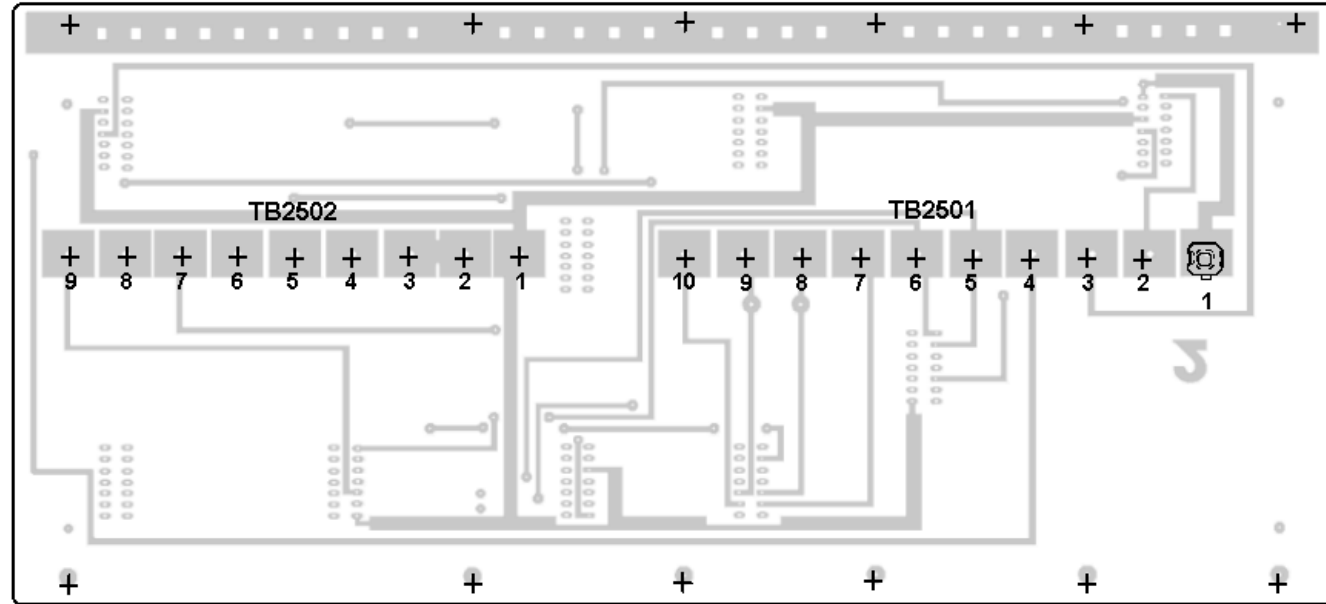

(19C321122, Rev. 0)
(19D417273, Sh. 3, Rev. 2)

BACK PLANE BOARD 19C320833G2

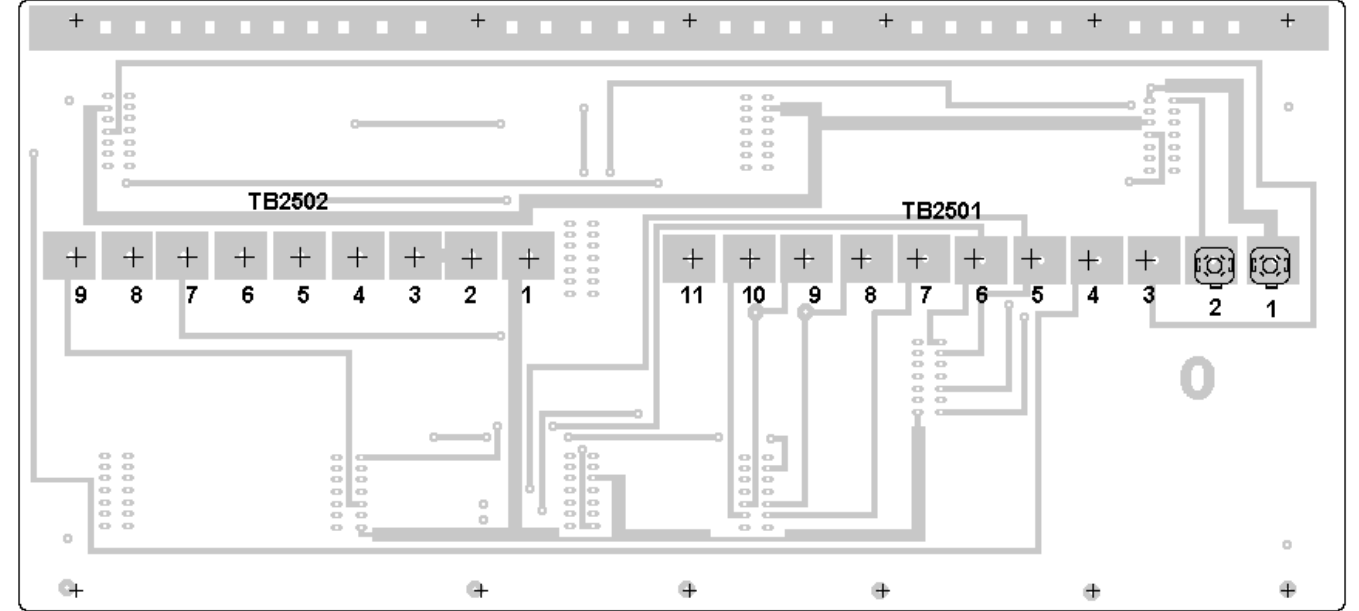

(19C327641, Rev. 0)
(19D423647, Sh. 3, Rev. 0)

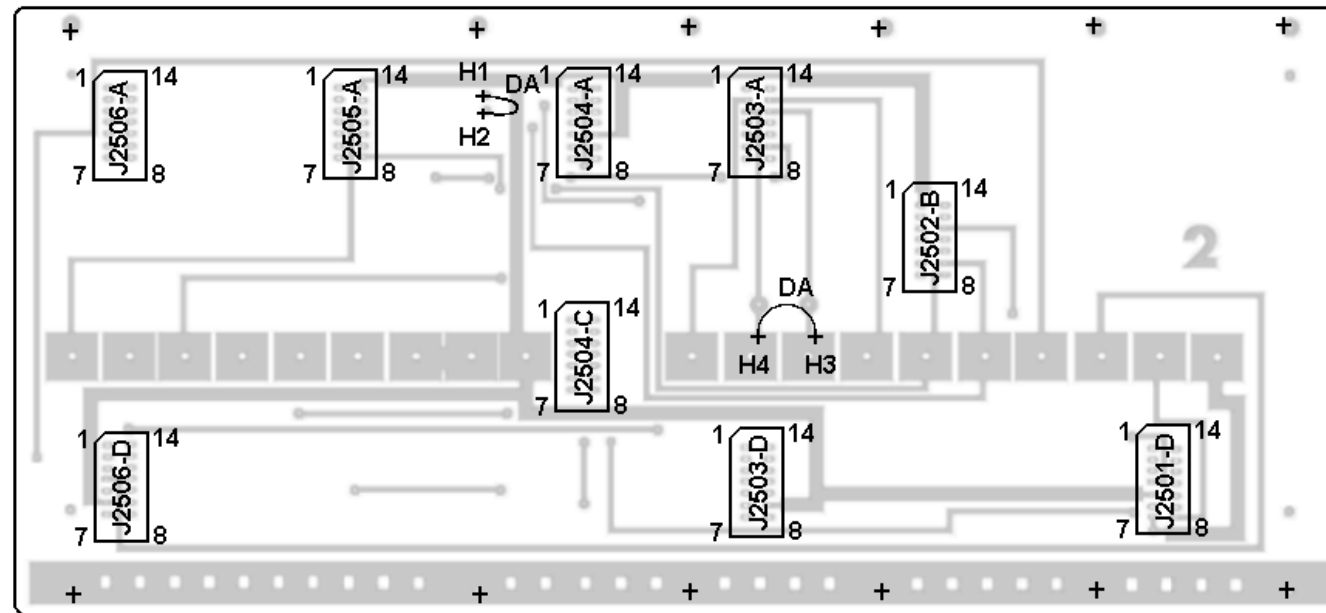

(19C321122, Rev. 0)
(19D417273, Sh. 3, Rev. 3)

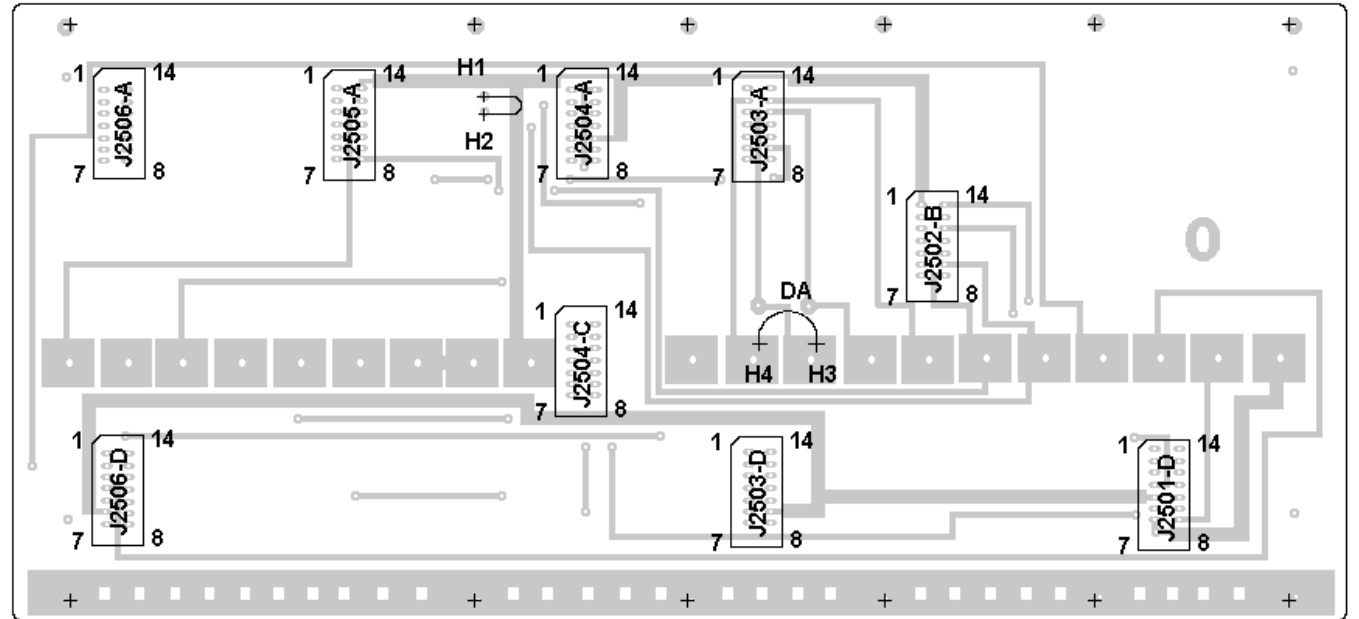

(19C327641, Rev. 0)
(19D423647, Sh. 3, Rev. 0)

CONTROL SHELF BACK PLANE
19C320833G1 & G2

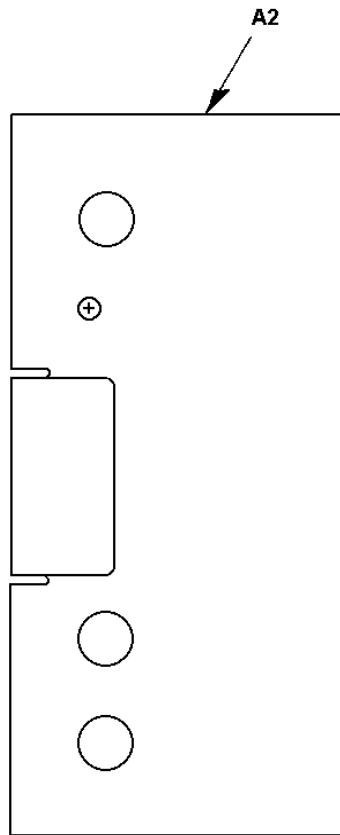

KEYING LOGIC & DC CONTROL BOARD 19D417452G2

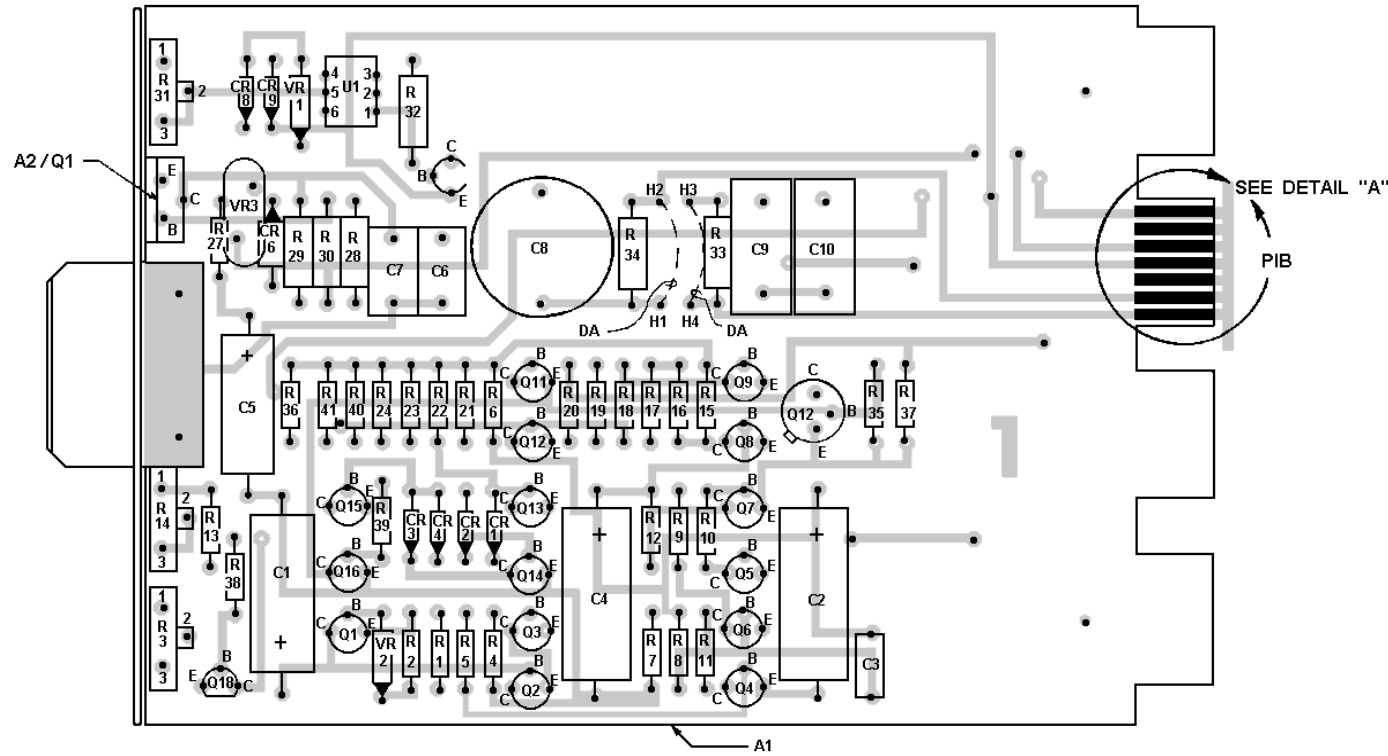

REAR VIEW OF A2

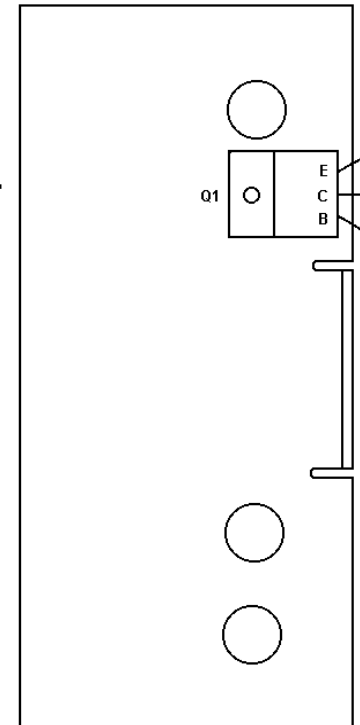

LEAD IDENTIFICATION FOR Q1, Q3, Q5, Q10, Q12

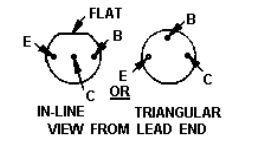

NOTE: LEAD ARRANGEMENT, AND NOT CASE SHAPE, IS DETERMINING FACTOR FOR LEAD IDENTIFICATION.



8 9 10 11 12 13 14
7 6 5 4 3 2 1
SOLDER SIDE
DETAIL "A"
TYP. NUMBERING OF CONT. FINGERS

LEAD IDENTIFICATION FOR Q2, Q4, Q6-Q9, Q11, Q13-Q18

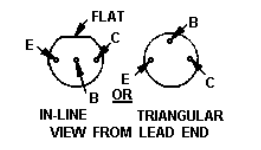

NOTE: LEAD ARRANGEMENT, AND NOT CASE SHAPE, IS DETERMINING FACTOR FOR LEAD IDENTIFICATION.

(19D429199, Rev. 2)
(19D423638, Sh. 3, Rev. 1)

TRANSMIT DETECTOR BOARD 19D417263G1

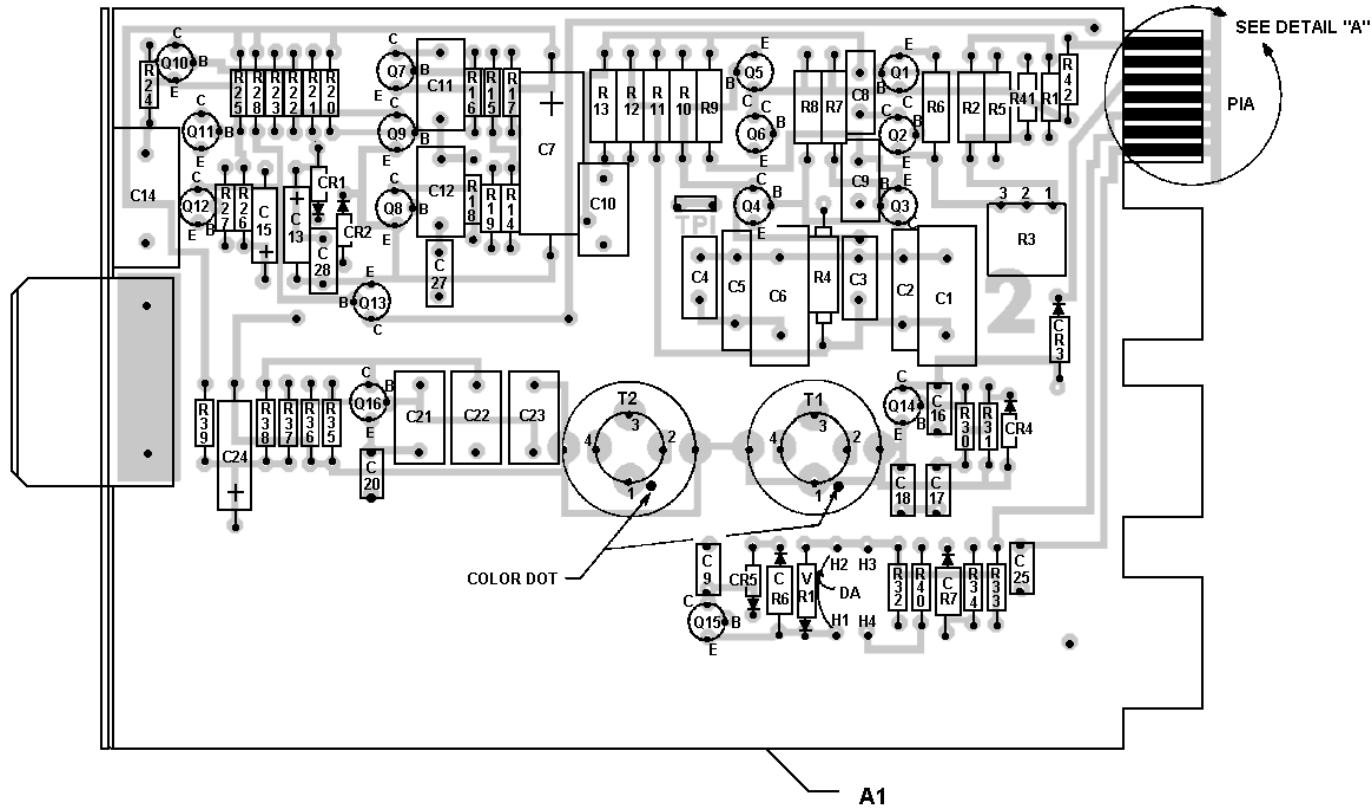

8 9 10 11 12 13 14
7 6 5 4 3 2 1
SOLDER SIDE
DETAIL "A"
TYP. NUMBERING OF CONT. FINGERS

LEAD IDENTIFICATION FOR Q1 - Q5, Q7, Q8, Q14 - Q16

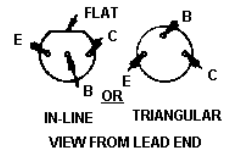

NOTE: LEAD ARRANGEMENT, AND NOT CASE SHAPE, IS DETERMINING FACTOR FOR LEAD IDENTIFICATION.

LEAD IDENTIFICATION FOR Q6, & Q9 - Q13

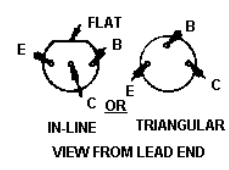

NOTE: LEAD ARRANGEMENT, AND NOT CASE SHAPE, IS DETERMINING FACTOR FOR LEAD IDENTIFICATION.

(19D417762, Rev. 5)
(19D417216, Sh. 3, Rev. 2)

KEYING LOGIC, DC CONTROL BOARD, AND TRANSMIT DETECTOR BOARD

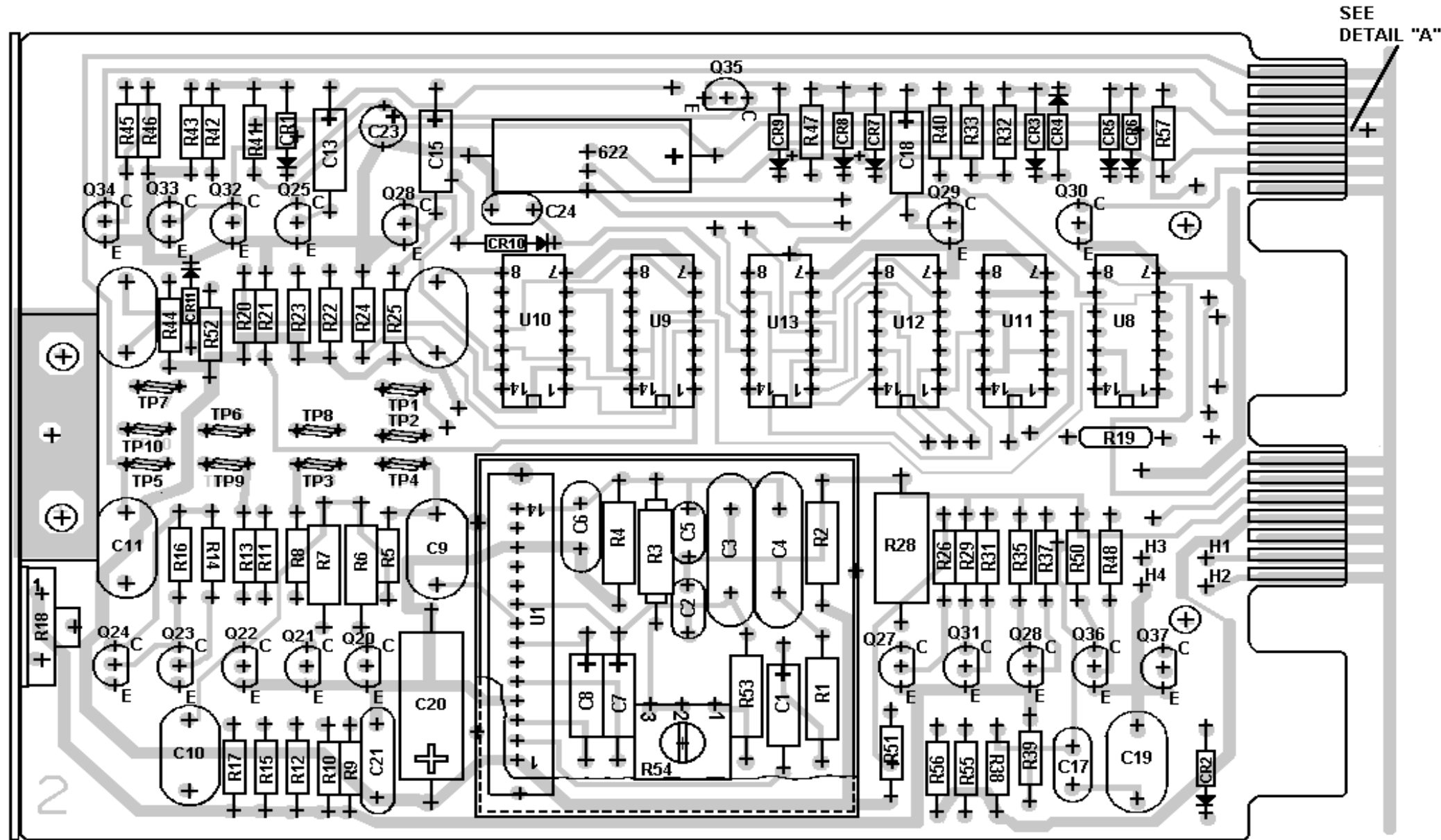

(19D433746, Rev. 1)
(19A144674, Sh. 1, Rev. 2)

LEAD IDENTIFICATION
FOR Q20 THRU Q38

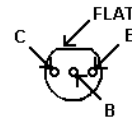

IN-LINE
TOP VIEW

NOTE: CASE SHAPE IS DETERMINING
FACTOR FOR LEAD IDENTIFICATION.

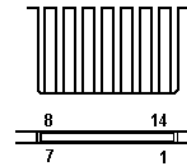

SOLDER SIDE
TYP. NUMBERING OF
CONTACT FINGERS.
DETAIL "A"

TONE CONTROL BOARD 19D417417G1

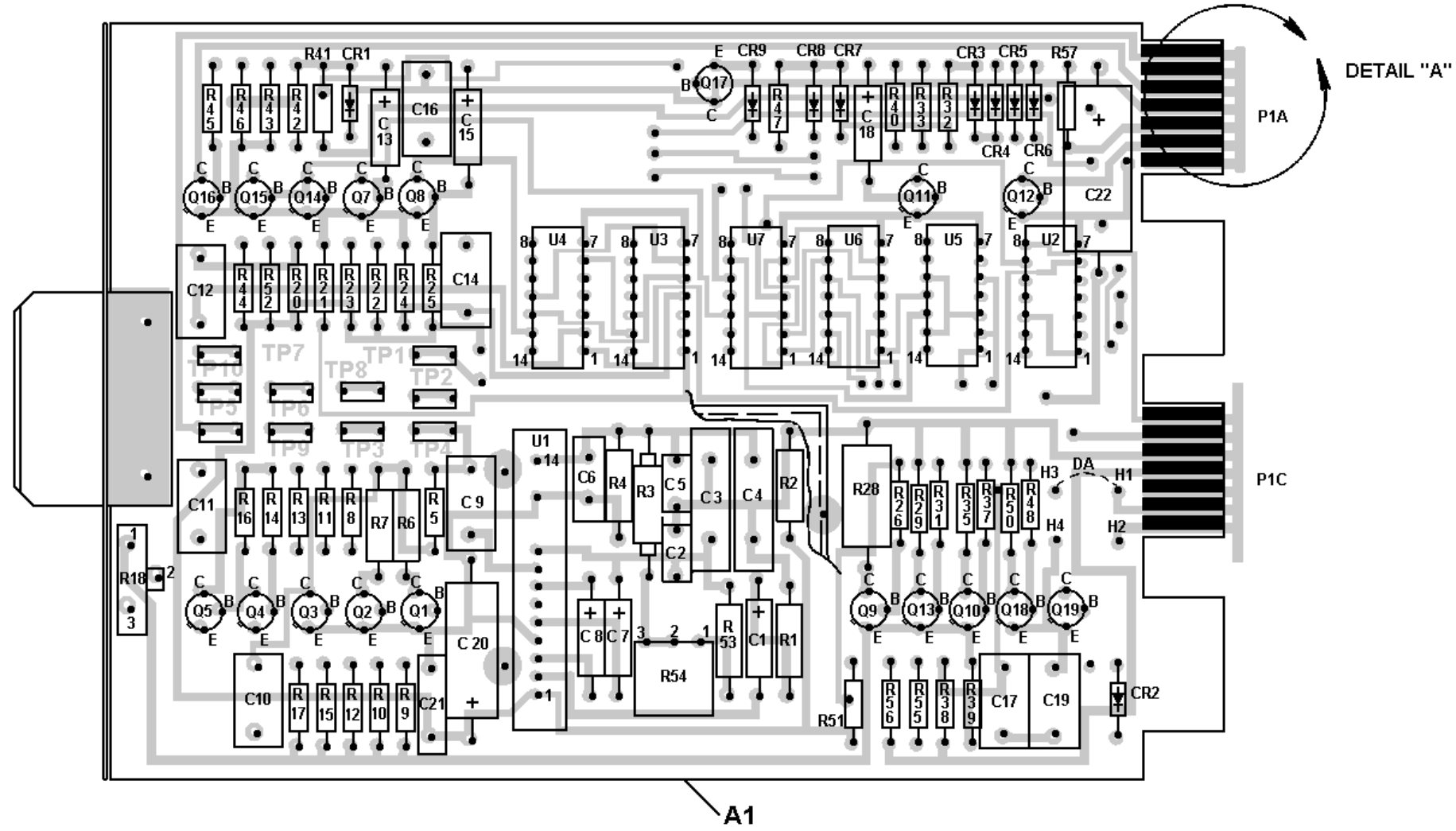

(19D417759, Rev. 0)
(19D417412, Sh. 3, Rev. 1)

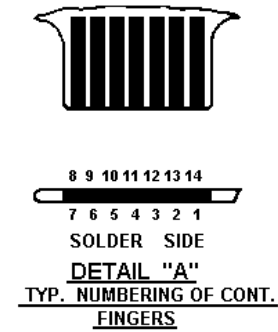
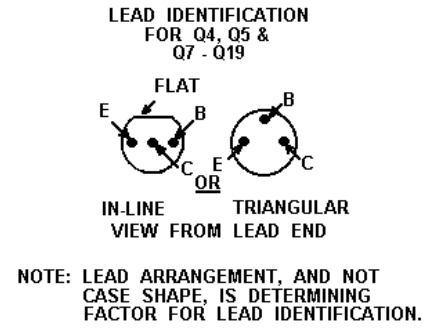
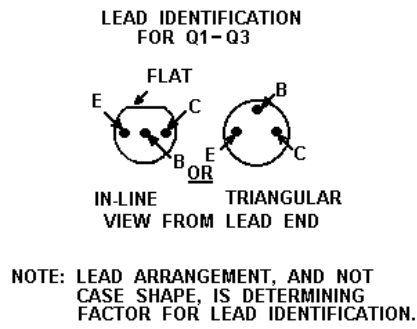

TONE CONTROL BOARD 19D417417G1
(USED IN EARLIER MODELS)

R1702, C1701, & L1701 ARE PART OF MOD KIT PL19A129317

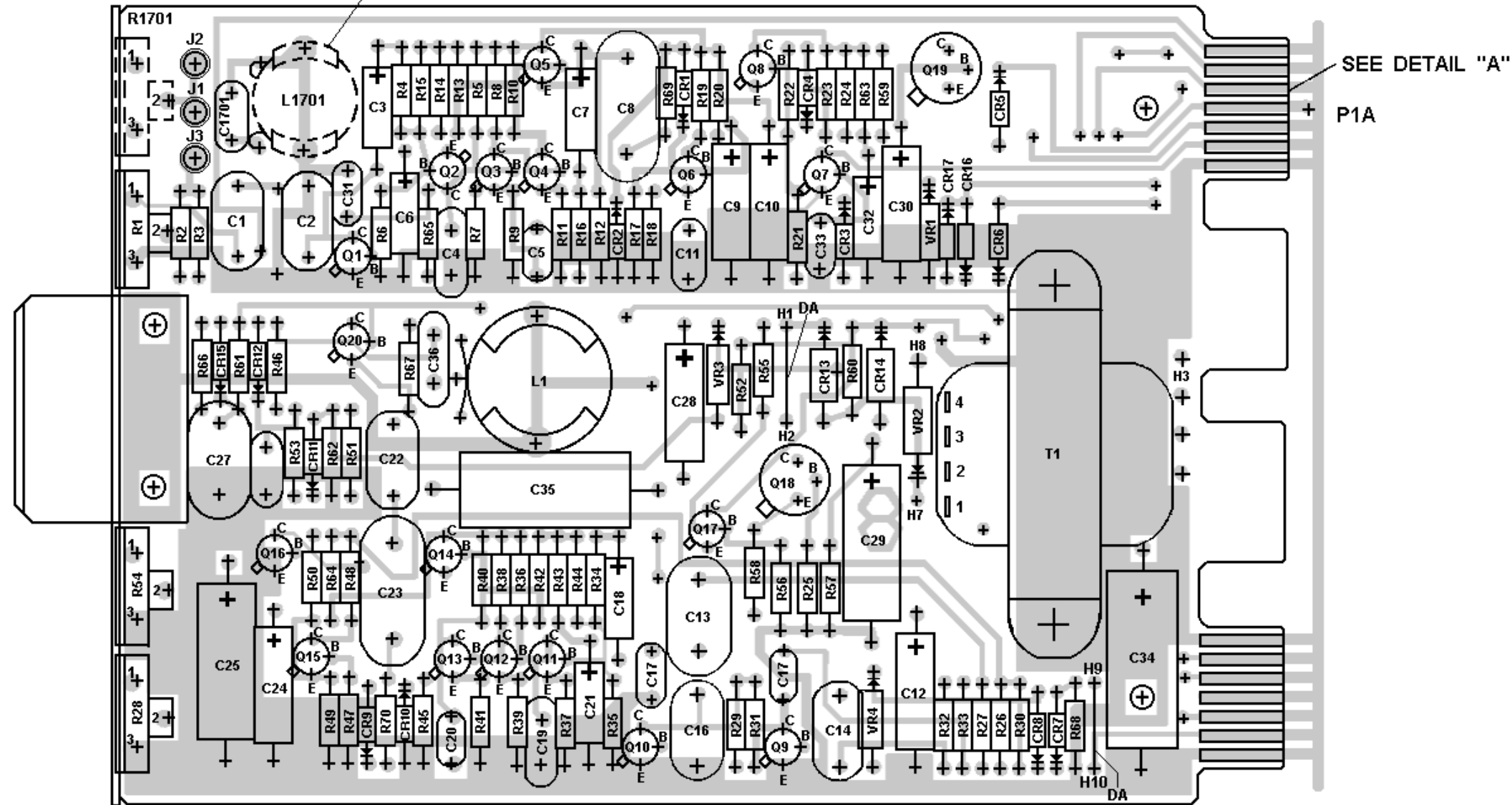

LEAD IDENTIFICATION FOR Q2 - Q4, Q5, Q8, & Q11 - Q14

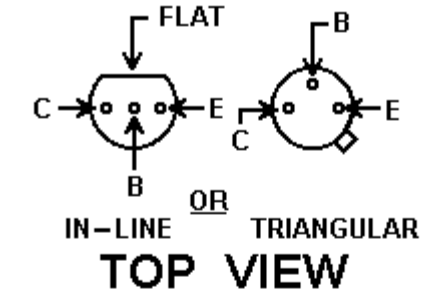

NOTE: LEAD ARRANGEMENT, AND NOT CASE SHAPE, IS DETERMINING FACTOR FOR IDENTIFICATION

LEAD IDENTIFICATION FOR Q1, Q6, Q7, Q9, Q10, & Q15 - Q20

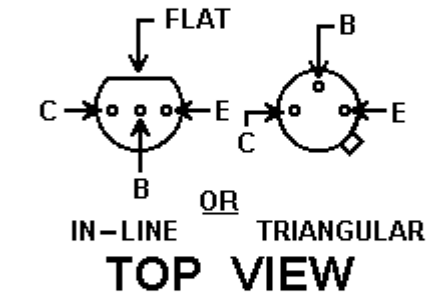

NOTE: LEAD ARRANGEMENT, AND NOT CASE SHAPE, IS DETERMINING FACTOR FOR IDENTIFICATION

A1
(19D417800, Rev. 7)
(19D417427, Sh. 3, Rev. 8)

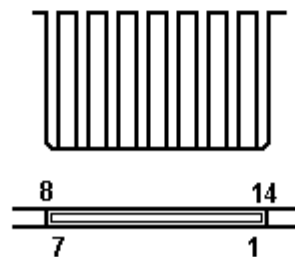

SOLDER SIDE TYP. NUMBERING OF CONTRACT FINGERS.

DETAIL "A"

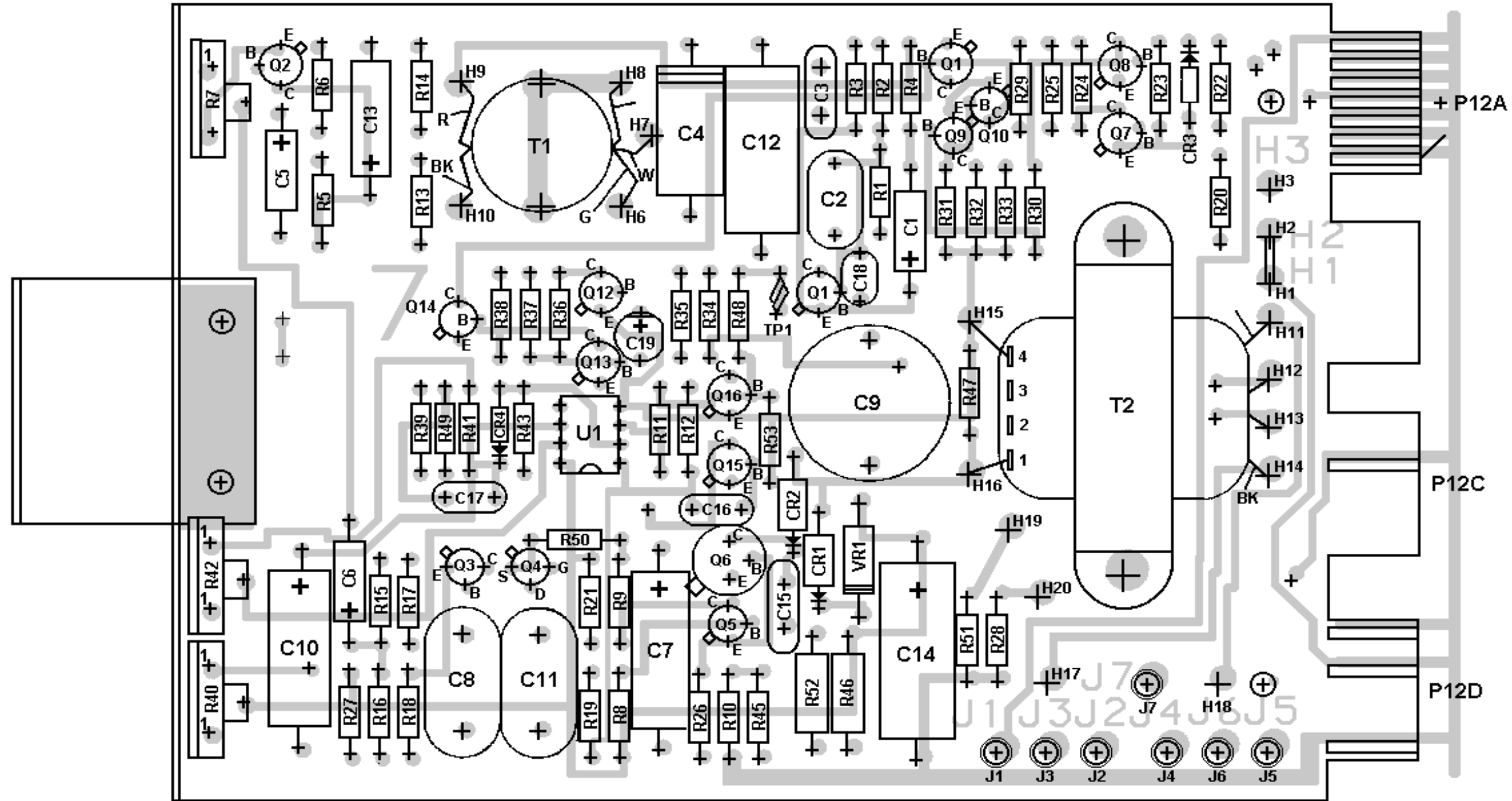

(19D417800, Rev. 9)
(19B226423, Sh. 3, Rev. 7)

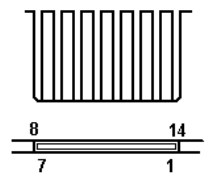

SOLDER SIDE
TYP. NUMBERING OF
CONTRACT FINGERS.
ROTATED 90° CW

DETAIL "A"

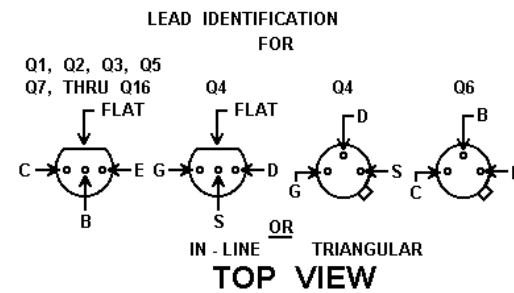

LEAD ARRANGEMENT, AND NOT
CASE SHAPE, IS DETERMINING
FACTOR FOR IDENTIFICATION

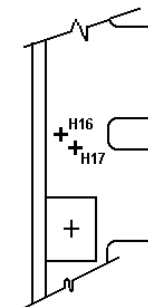
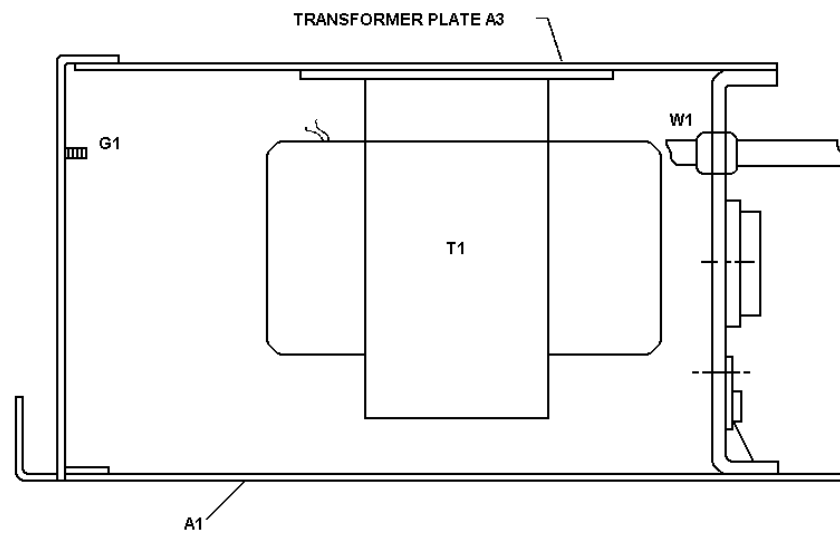
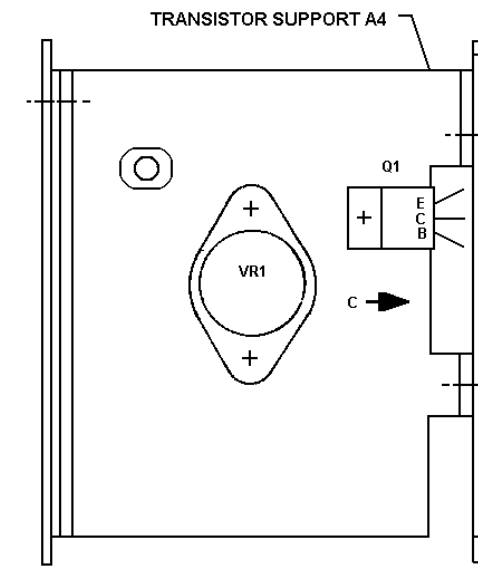
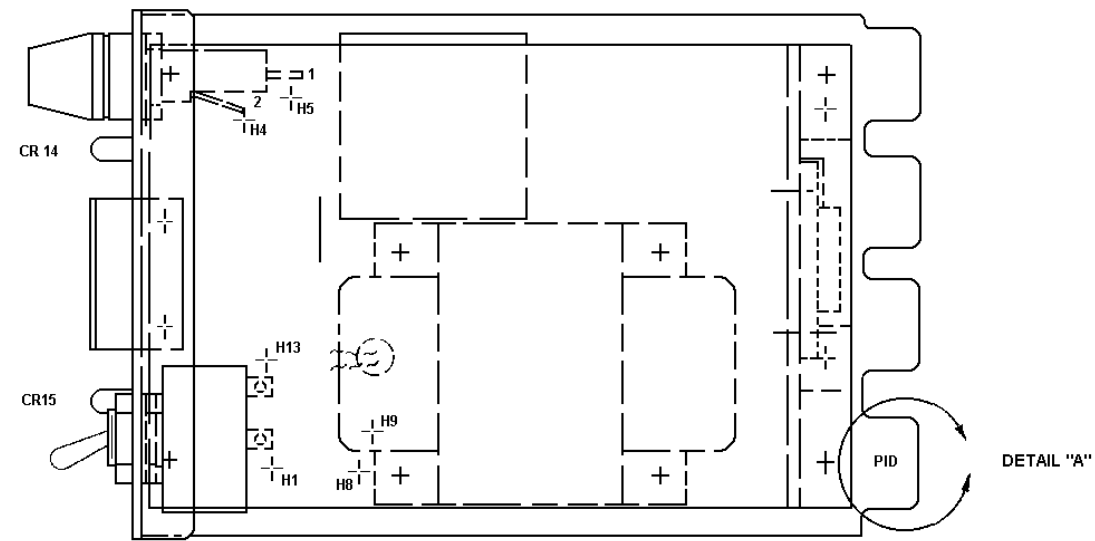
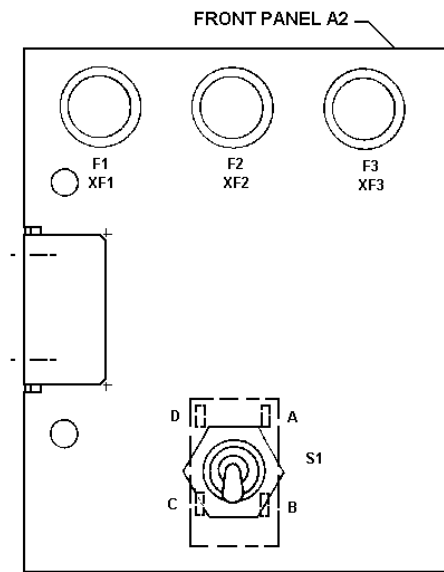
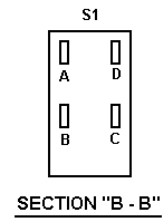

VIEW AT "C"
(PARTIAL)

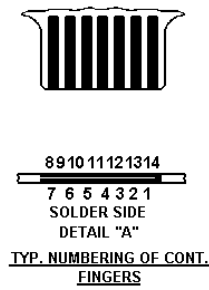

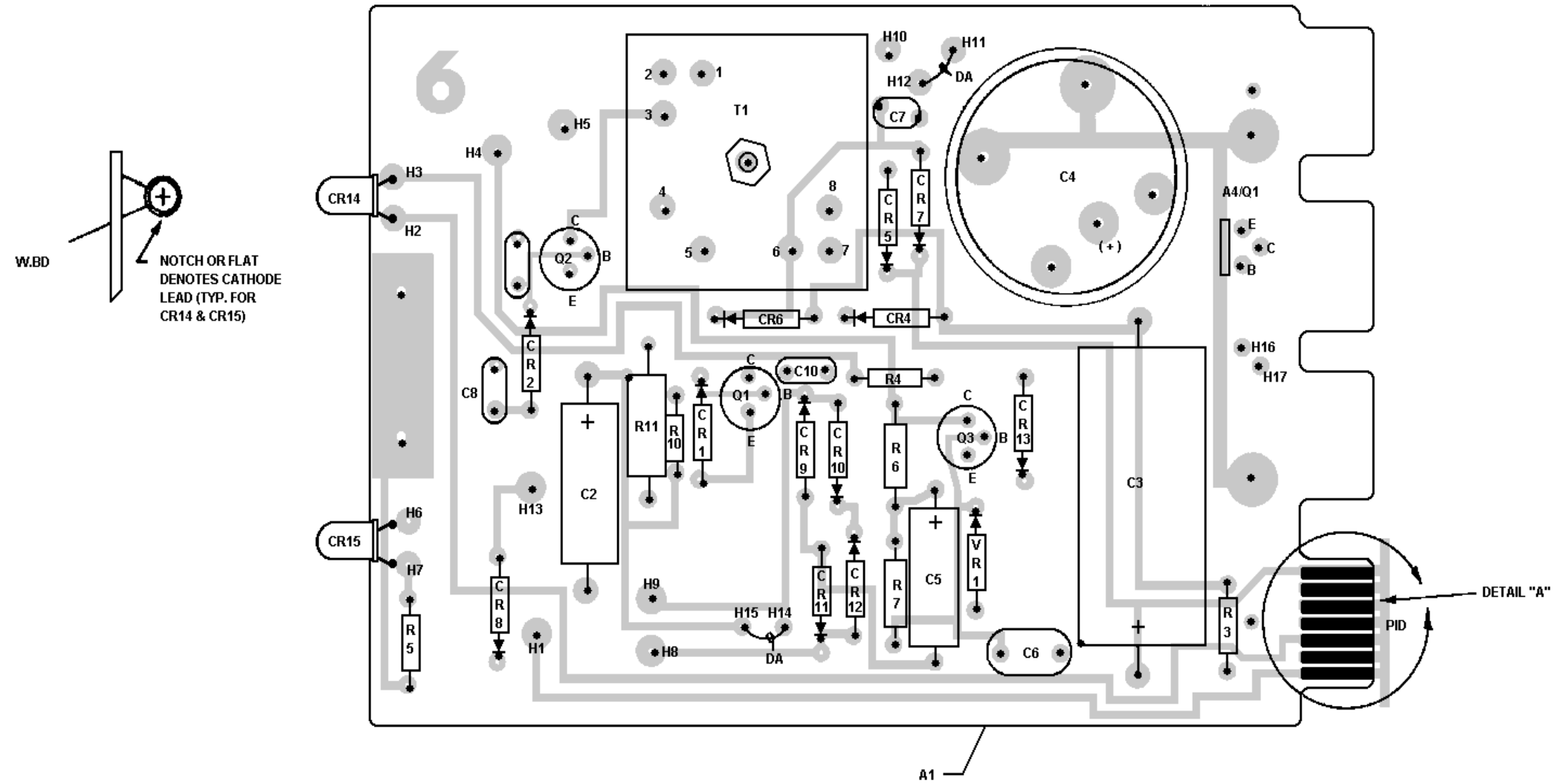

(19D417771, Rev. 5)
(19D417418, Sh. 3, Rev. 6)

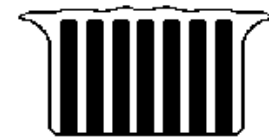

89 10 11 12 13 14
7 6 5 4 3 2 1
SOLDER SIDE
DETAIL "A"

TYP. NUMBERING OF CONT. FINGERS

LEAD IDENTIFICATION FOR Q1 - Q3



VIEW FROM LEAD END

NOTE: LEAD ARRANGEMENT, AND NOT CASE SHAPE, IS DETERMINING FACTOR FOR LEAD IDENTIFICATION.

RECTIFIER BOARD A1
19D417428G1

PARTS LIST
LBI-4649
REMOTE KEYING CONTROL SHELF
19D416725G2

SYMBOL	PART NO.	DESCRIPTION
----- JACKS AND RECEPTACLES -----		
J2501D	19A116446P5	Connector, printed wiring: 14 contacts
J2502B	19A116446P5	Connector, printed wiring: 14 contacts
J2503A	19A116446P5	Connector, printed wiring: 14 contacts
J2503D	19A116446P5	Connector, printed wiring: 14 contacts
J2504A	19A116446P5	Connector, printed wiring: 14 contacts
J2504C	19A116446P5	Connector, printed wiring: 14 contacts
J2505A	19A116446P5	Connector, printed wiring: 14 contacts
J2506A	19A116446P5	Connector, printed wiring: 14 contacts
J2506D	19A116446P5	Connector, printed wiring: 14 contacts
----- TERMINAL BOARDS -----		
TB501	19A116667P3	Nut, plate: No. 6-32, sim to Malco X0-2879. (Quantity 10).
TB502	19A116667P3	Nut, plate: No. 6-32, sim to Malco X0-2879. (Quantity 9).
----- MISCELLANEOUS -----		
	19C315963P1	Card guide.
	19C320832P1	Insulator.
	NF276445	Nameplate.

*COMPONENTS ADDED, DELETED OR CHANGED BY PRODUCTION CHANGES

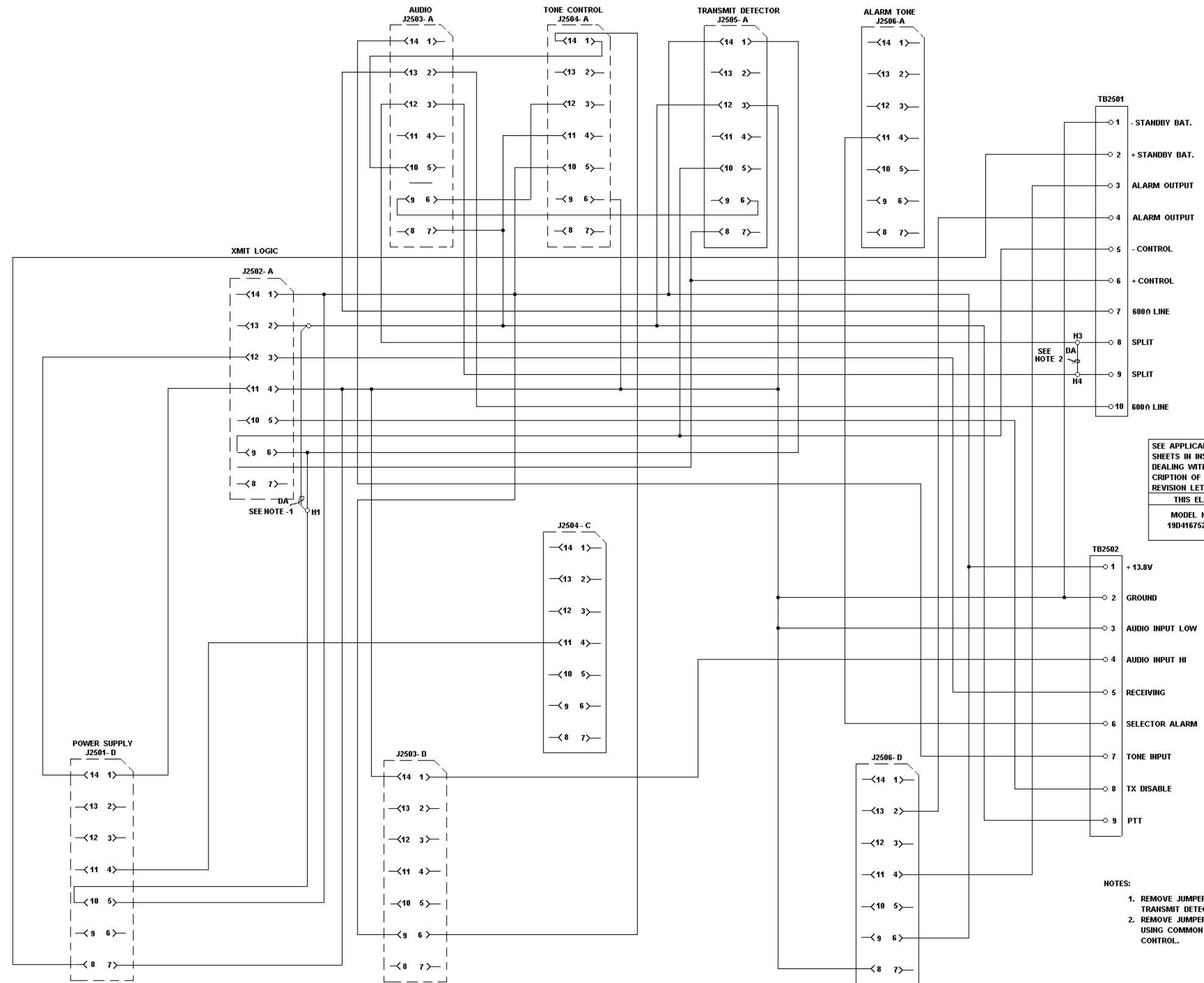

SEE APPLICABLE PRODUCTION CHANGE SHEETS IN INSTRUCTION BOOK SECTION DEALING WITH THIS UNIT. FOR DESCRIPTION OF CHANGES UNDER EACH REVISION LETTER.

THIS ELEM DIAG APPLIES TO	
MODEL NO.	REV LETTER
19D416725G2	

- NOTES:
1. REMOVE JUMPER FROM H1 TO H2 WHEN TRANSMIT DETECTOR IS USED.
 2. REMOVE JUMPER FROM H3 TO H4 WHEN USING COMMON PAIR FOR AUDIO AND CONTROL.

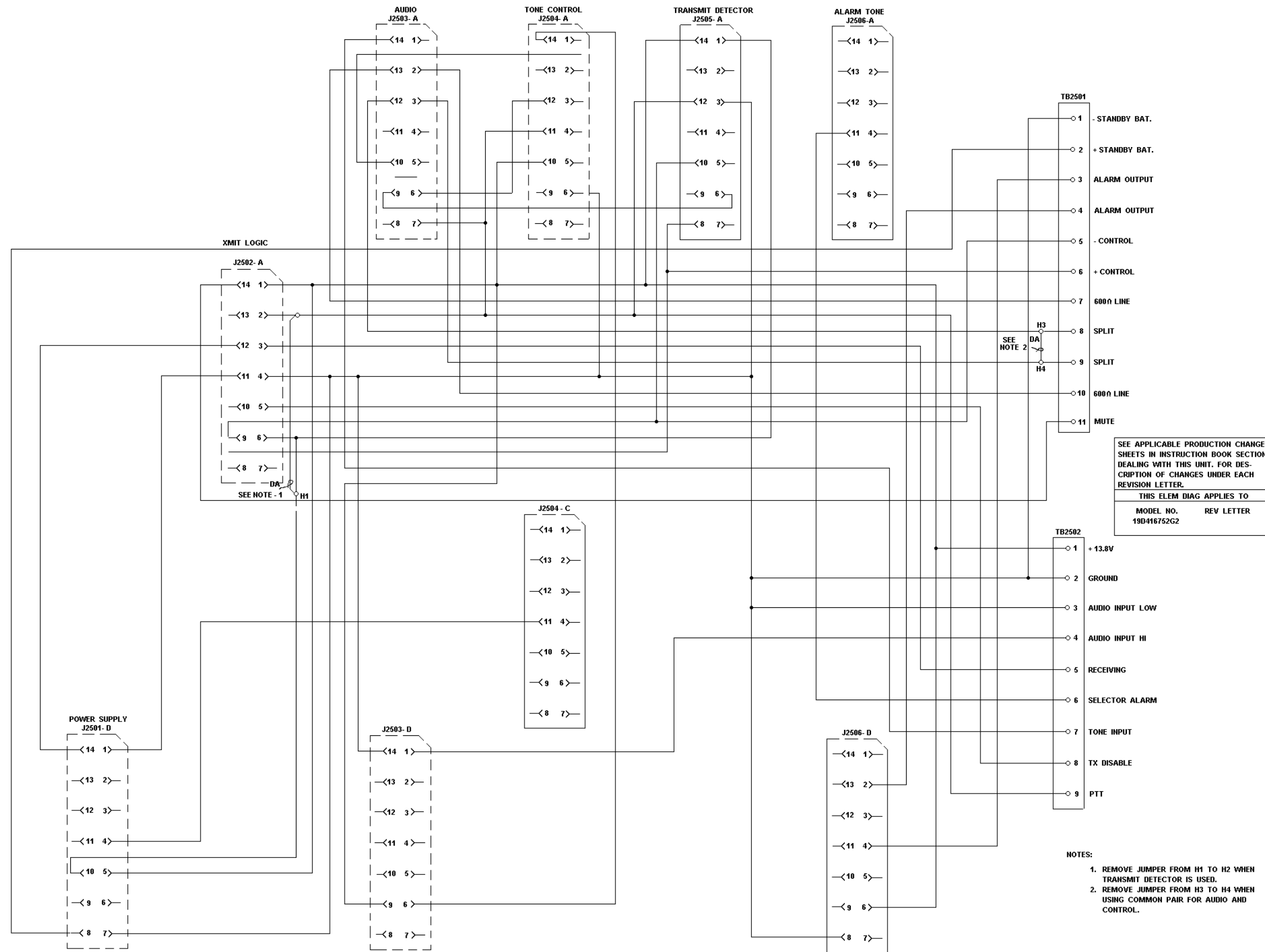

PARTS LIST

LBI30375A
REMOTE KEYING CONTROL SHELF
19D416725G4 - REV A

SYMBOL	PART NO.	DESCRIPTION
		COMPONENT BOARD 19C320833G2
		----- JACKS AND RECEPTACLES -----
J2501D	19A116446P5	Connector, printed wiring: 14 contacts rated at 3 amps.
J2502B	19A116446P5	Connector, printed wiring: 14 contacts rated at 3 amps.
J2503A	19A116446P5	Connector, printed wiring: 14 contacts rated at 3 amps.
J2503D	19A116446P5	Connector, printed wiring: 14 contacts rated at 3 amps.
J2504A	19A116446P5	Connector, printed wiring: 14 contacts rated at 3 amps.
J2504C	19A116446P5	Connector, printed wiring: 14 contacts rated at 3 amps.
J2505A	19A116446P5	Connector, printed wiring: 14 contacts rated at 3 amps.
J2506A	19A116446P5	Connector, printed wiring: 14 contacts rated at 3 amps.
J2506D	19A116446P5	Connector, printed wiring: 14 contacts rated at 3 amps.
		----- TERMINAL BOARDS -----
TB501	19A116667P3	Nut, plate: No. 6-32; sim to Malco X0-2879. (Quantity 11).
TB502	19A116667P3	Nut, plate: No. 6-32; sim to Malco X0-2879. (Quantity 9).
		----- MISCELLANEOUS -----
	19C315963P1	Card guide.
	19C321906P1	Insulator.
	MP276445	Nameplate.
	SXA1204505/606	Tap screw, Phillips F02IDRIV®: No. 6-32 x 5/16.
	19J706152P4	Retaining strap: sim to Panduit Corp. TA-1.

*COMPONENTS ADDED, DELETED OR CHANGED BY PRODUCTION CHANGES

PRODUCTION CHANGES

Changes in the equipment to improve performance or to simplify circuits are identified by a "Revision Letter", which is stamped after the model number of the unit. The revision stamped on the unit includes all previous revisions. Refer to the Parts List for descriptions of parts affected by these revisions.

To load the phone line correctly. Connected TB2501-3 to TB2501-7 and TB2501-4 to TB2501-10.

- NOTES:
1. REMOVE JUMPER FROM H1 TO H2 WHEN TRANSMIT DETECTOR IS USED.
 2. REMOVE JUMPER FROM H3 TO H4 WHEN USING COMMON PAIR FOR AUDIO AND CONTROL.

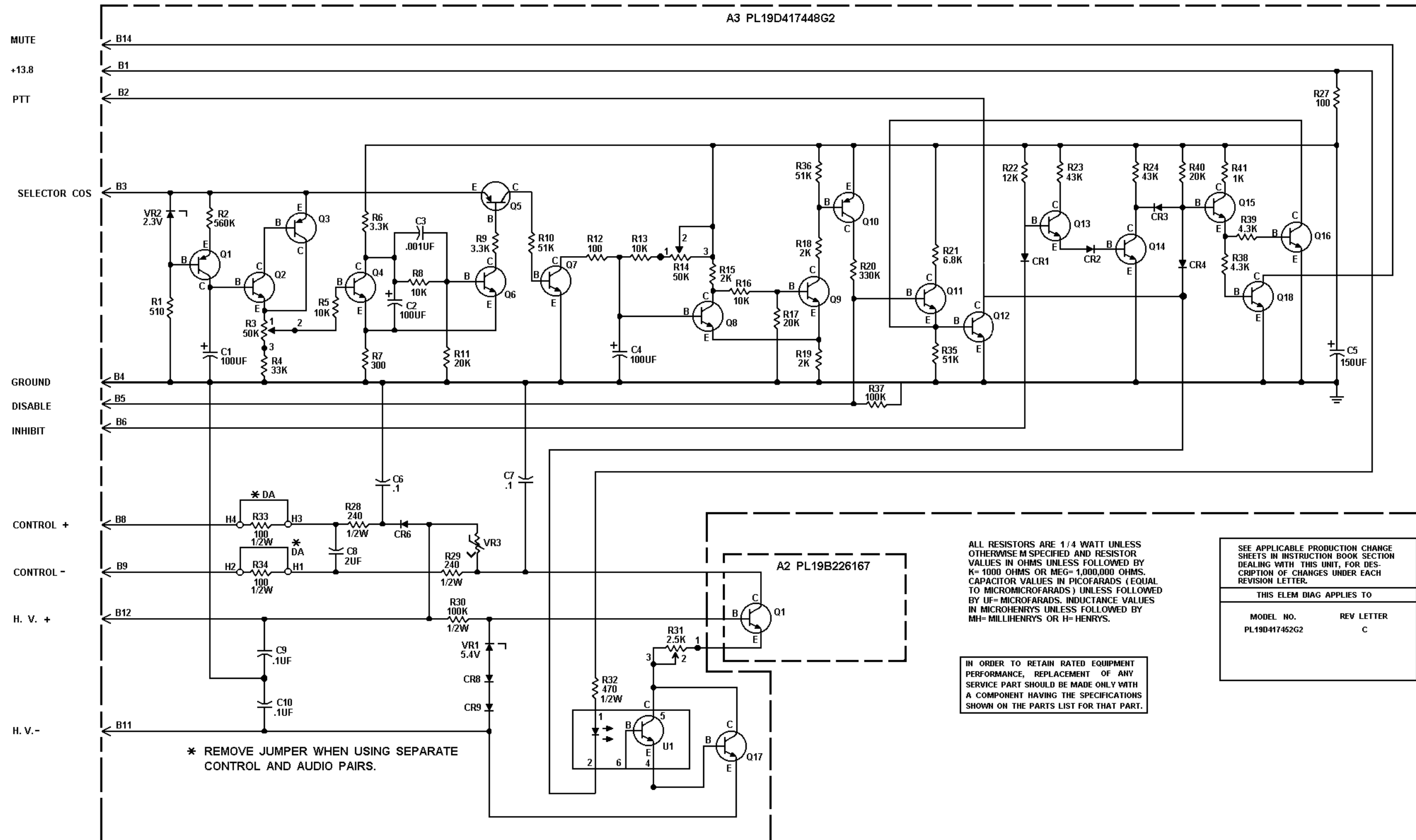

ALL RESISTORS ARE 1/4 WATT UNLESS OTHERWISE SPECIFIED AND RESISTOR VALUES IN OHMS UNLESS FOLLOWED BY K= 1000 OHMS OR MEG= 1,000,000 OHMS. CAPACITOR VALUES IN PICOFARADS (EQUAL TO MICROMICROFARADS) UNLESS FOLLOWED BY UF= MICROFARADS. INDUCTANCE VALUES IN MICROHENRYS UNLESS FOLLOWED BY MH= MILLIHENRYS OR H= HENRYS.

SEE APPLICABLE PRODUCTION CHANGE SHEETS IN INSTRUCTION BOOK SECTION DEALING WITH THIS UNIT, FOR DESCRIPTION OF CHANGES UNDER EACH REVISION LETTER.	
THIS ELEM DIAG APPLIES TO	
MODEL NO. PL19D417452G2	REV LETTER C

IN ORDER TO RETAIN RATED EQUIPMENT PERFORMANCE, REPLACEMENT OF ANY SERVICE PART SHOULD BE MADE ONLY WITH A COMPONENT HAVING THE SPECIFICATIONS SHOWN ON THE PARTS LIST FOR THAT PART.

KEYING LOGIC & DC CONTROL BOARD
19D417452G2

(19D423639, Rev. 4)

PARTS LIST

LBI30593D
TRANSMIT LOGIC AND DC CONTROL BOARD
19D417452G2 - REV C

SYMBOL	PART NO.	DESCRIPTION
A2		TRANSISTOR SUPPORT ASSEMBLY 19B226167G1
Q1	19A129183P1	Silicon, NPN.
A3		COMPONENT BOARD 19D417448G2
		----- CAPACITORS -----
C1*	19A115680P7	Electrolytic; 100 uF +150-10%, 15 VDCW; sim to Mallory Type TTX.
	19B200240P3	Earlier than REV A: Tantalum: 150 uF ±20%, 15 VDCW.
C2	19A115680P7	Electrolytic; 100 uF +150-10%, 15 VDCW; sim to Mallory Type TTX.
C3	7774750P4	Ceramic disc: .001 uF +100% -0%, 500 VDCW.
C4	19A113680P7	Electrolytic; 100 uF +150-10%, 15 VDCW; sim to Mallory Type TTX.
C5	5496267P12	Tantalum: 150 uF ±20%, 15 VDCW; sim to Sprague Type 150D.
C6 and C7	19A116080P107	Polyester: 0.1 uF ±10%, 50 VDCW.
C8	7486445P6	Electrolytic, non polarized: 2 uf -10 + 100%, 200 VDCW.
C9 and C10	19A115028P14	Polyester: 0.1 uf ±20%, 200 VDCW.
		----- DIODES AND RECTIFIERS -----
CR1 thru CR4	19A115250P1	Silicon, fast recovery, 225 mA, 50 PIV.
CR6	19A704142P2	General Purpose Silicon; sim to 1N4005.
CR7	4037822P2	Silicon, 1000 mA, 600 PIV. Deleted by REV C.
CR8 and CR9	19A115250P1	Silicon, fast recovery, 225 mA, 50 PIV.
		----- PLUGS -----
P1		(Part of printed board 19D417445P1).
		----- TRANSISTORS -----
Q1	19A115768P1	Silicon, PNP; sim to Type 2N3702.
Q2	19A115910P1	Silicon, NPN; sim to Type 2N3904.
Q3	19A115768P1	Silicon, PNP; sim to Type 2N3702.
Q4	19A115910P1	Silicon, NPN; sim to Type 2N3904.
Q5	19A115768P1	Silicon, PNP; sim to Type 2N3702.
Q6 thru Q9	19A115910P1	Silicon, NPN; sim to Type 2N3904.
Q10	19A115768P1	Silicon, PNP; sim to Type 2N3702.
Q11	19A115910P1	Silicon, NPN; sim to Type 2N3904.
Q12	19A115910P1	Silicon, NPN.
Q13 thru Q18	19A115910P1	Silicon, NPN; sim to Type 2N3904.
		----- RESISTORS -----
R1	3R152P511J	Composition: 510 ohms ±5%, 1/4 w.

SYMBOL	PART NO.	DESCRIPTION
R2	3R152P564J	Composition: 560K ohms ±5%, 1/4 w.
R3	19B209358P108	Variable, carbon film: approx 2K to 50K ohms ±10%, 1/4 w; sim to CTS Type X-201.
R4	19A700106P99	Composition: 33K ohms ±5%, 1/4 w.
R5	19A700106P87	Composition: 10K ohms ±5%, 1/4 w.
R6	19A700106P75	Composition: 3.3K ohms ±5%, 1/4 w.
R7	3R152P301J	Composition: 300 ohms ±5%, 1/4 w.
R8	19A700106P87	Composition: 10K ohms ±5%, 1/4 w.
R9	19A700106P75	Composition: 3.3K ohms ±5%, 1/4 w.
R10	3R152P513J	Composition: 51K ohms ±5%, 1/4 w.
R11	3R152P203J	Composition: 20K ohms ±5%, 1/4 w.
R12	19A700106P39	Composition: 100 ohms ±5%, 1/4 w.
R13	19A700106P87	Composition: 10K ohms ±5%, 1/4 w.
		In Rev A & earlier:
R14	3R152P222J	Composition: 2.2K ohms ±5%, 1/4 w.
R15	19B209358P108	Variable, carbon film: approx 2K to 50K ohms ±10%, 1/4 w; sim to CTS Type X-201.
R16	3R152P202J	Composition: 2K ohms ±5%, 1/4 w.
R17	19A700106P87	Composition: 10K ohms ±5%, 1/4 w.
R18 and R19	3R152P203J	Composition: 20K ohms ±5%, 1/4 w.
R20	3R152P334J	Composition: 0.33 megohms ±5%, 1/4 w.
R21	19A700106P83	Composition: 6.8K ohms ±5%, 1/4 w.
R22	19A700106P89	Composition: 12K ohms ±5%, 1/4 w.
R23 and R24	3R152P433J	Composition: 43K ohms ±5%, 1/4 w.
R27	19A700106P39	Composition: 100 ohms ±5%, 1/4 w.
R28 and R29	3R77P241J	Composition: 240 ohms ±5%, 1/2 w.
R30	19A700113P111	Composition: 100 ohms ±5%, 1/2 w.
R31	19B209358P104	Variable, carbon film: approx 50 to 2500 ohms ±10%, 1/4 w; sim to CTS Type X-201.
R32	19A700113P55	Composition: 470 ohms ±5%, 1/2 w.
R33 and R34	19A700113P39	Composition: 100 ohms ±5%, 1/2 w.
R35 and R36	3R152P513J	Composition: 51K ohms ±5%, 1/4 w.
R37	19A700106P111	Composition: 100 ohms ±5%, 1/4 w.
R38 and R39	3R152P432J	Composition: 4.3K ohms ±5%, 1/4 w.
R40	3R152P203J	Composition: 20K ohms ±5%, 1/4 w.
R41	19A700106P63	Composition: 1K ohms ±5%, 1/4 w.
		----- INTEGRATED CIRCUITS -----
U1	19A116908P1	Coupler, optoelectronic: 6 pin, dual in line; sim to Fairchild FCD-5004.
		----- VOLTAGE REGULATORS -----
VR1	4036887P5	Zener: 500 mW, 5.4 v. nominal.
VR2	4036887P1	Zener: 500 mW, 2.3 v. nominal.
VR3*	19A134142P1	Electrical surge arrester, (Variator): sim to CE SPD #V130LAX576. Added by REV C.
		----- MISCELLANEOUS -----
	19A701332P4	Insulator, washer: nylon. (Used with Q12 and A3).
	19A116023P1	Insulator, plate. (Used with Q1 and A2).
	19A116022P1	Insulator, bushing. (Used with Q1 and A2).
	19B219690C1	Handle assembly.

PRODUCTION CHANGES

Changes in the equipment to improve performance or to simplify circuits are identified by a "Revision Letter", which is stamped after the model number of the unit. The revision stamped on the unit includes all previous revisions. Refer to the Parts List for descriptions of parts affected by these revisions.

- REV. A - To reduce minimum PTT release time after COS voltage is removed. Changed C1.
- REV. B - To increase time delay when pot is at minimum specification. Changed R13.
- REV. C - To prevent the remote keying panel from defeating the "Repeater Disable" and "Channel Guard Disable" when it is connected in parallel with a console. Replaced CR7 with VR3.

*COMPONENTS ADDED, DELETED OR CHANGED BY PRODUCTION CHANGES

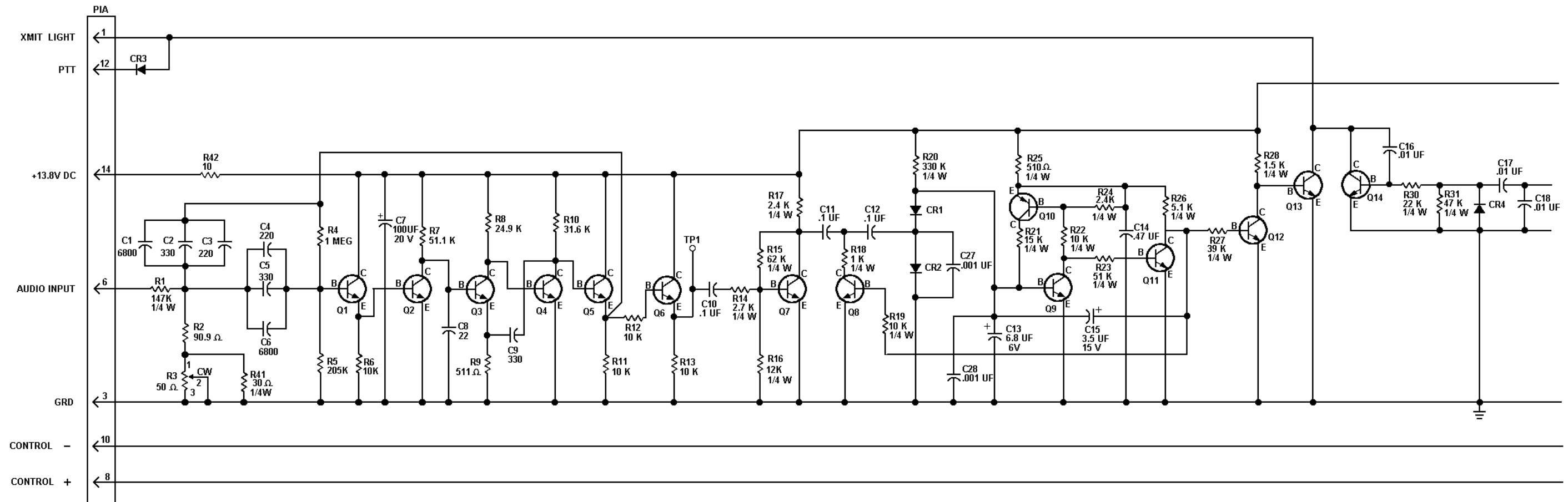

SEE APPLICABLE PRODUCTION CHANGE SHEETS IN INSTRUCTION BOOK SECTION DEALING WITH THIS UNIT, FOR DESCRIPTION OF CHANGES UNDER EACH REVISION LETTER.

THIS ELEM DIAG APPLIES TO

MODEL NO.	REV. LETTER
PL19D417263G1	C

ALL RESISTORS ARE 1/2 WATT UNLESS OTHERWISE SPECIFIED AND RESISTOR VALUES IN OHMS UNLESS FOLLOWED BY K=1000 OHMS OR MEG=1,000,000 OHMS. CAPACITOR VALUES IN PICOFARADS (EQUAL TO MICROMICROFARADS) UNLESS FOLLOWED BY UF=MICROFARADS. INDUCTANCE VALUES IN MICROHENRYS UNLESS FOLLOWED BY MH=MILLIHENRYS OR H=HENRYS.

IN ORDER TO RETAIN RATED EQUIPMENT PERFORMANCE, REPLACEMENT OF ANY SERVICE PART SHOULD BE MADE ONLY WITH A COMPONENT HAVING THE SPECIFICATIONS SHOWN ON THE PARTS LIST FOR THAT PART.

**TRANSMIT DETECTOR BOARD
19D417263G1**

(19R600757, Rev. 7)

PRODUCTION CHANGES

Changes in the equipment to improve performance or to simplify circuits are identified by a "Revision Letter", which is stamped after the model number of the unit. The revision stamped on the unit includes all previous revisions. Refer to the Parts List for descriptions of parts affected by these revisions.

- REV. A - To increase tone detect sensitivity. Changed value of Q7 and R14.
- REV. B - To shift 2175 Hz tone peak to center of R3 adjustable range.
- REV. C - To eliminate falsing of the transmit light and inhibit path due to spikes from the HV Power Supply Chopper on the +13.8 V BUS. Added R42.

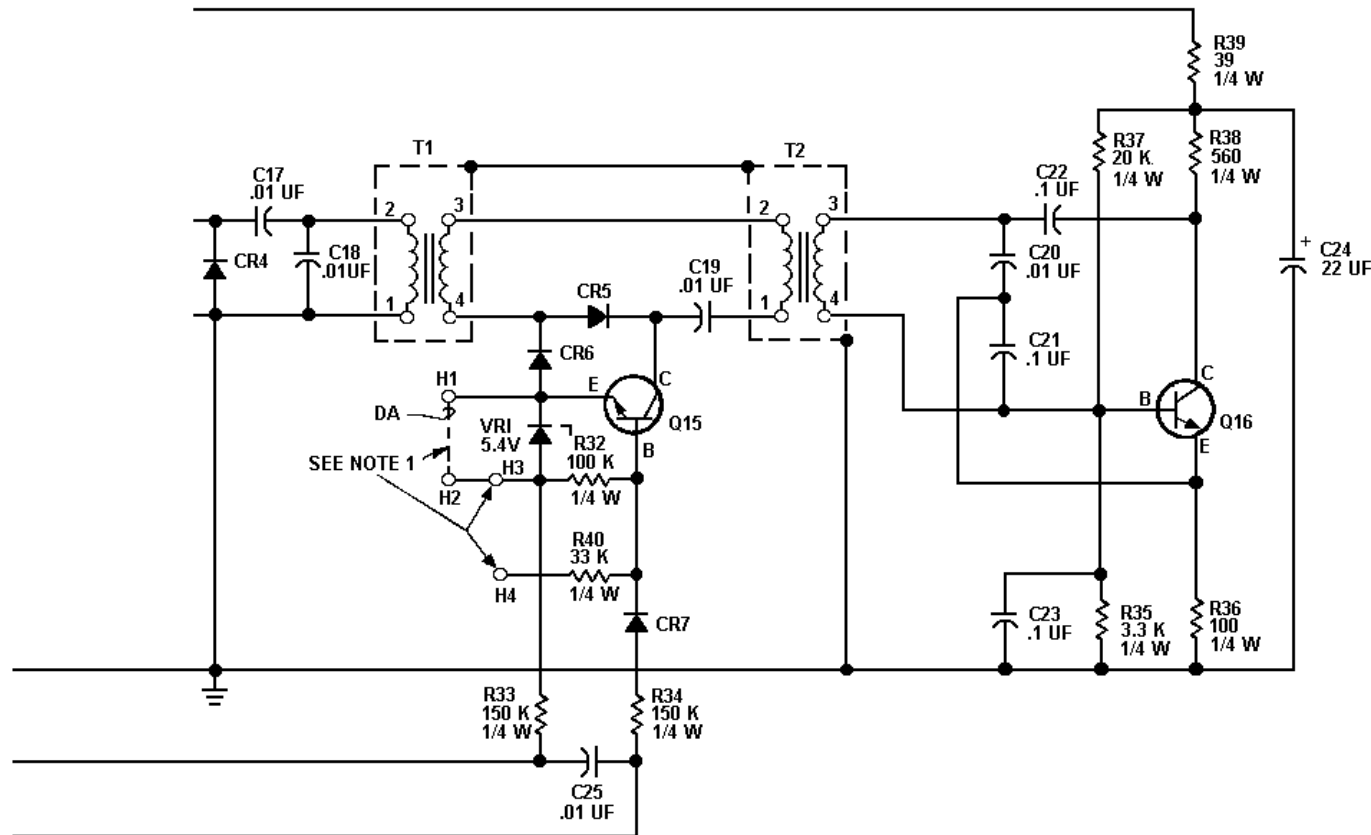

NOTES:

1. WHEN C.G. MON. CURRENT IS +6 MA INSTEAD OF -2.5 MA, REMOVE JUMPER BETWEEN H1 & H2 AND CONNECT A JUMPER BETWEEN H3 & H4.

TRANSMIT DETECTOR BOARD
19D417263G1

LBI4652C

TRANSMIT DETECTOR BOARD
19D417263G1 - REV C

SYMBOL	PART NO.	DESCRIPTION
A1		Component Board 19D417425G1
----- CAPACITORS -----		
C1	5491871P6800G	Mica: 6800 pF + or - 2%, 300 VDCS; sim to Electro Motive Type DM-20.
C2	5496219P875	Ceramic disc: 330 pF + or - 5%, 500 VDCW, temp. coef -1500 PPM.
C3 and C4	7489162P235	Silver mica: 220 pF + or - 2%, 500 VDCW; sim. to Sprague Type 118.
C5	5496219P875	Ceramic disc: 330 pF + or - 5%, 500 VDCW, temp. coef -1500 PPM.
C6	5491871P6800G	Mica: 6800 pF + or - 2%, 300 VDCS; sim to Electro Motive Type DM-20.
C7	5496267P16	Tantalum: 100 uF + or - 20%, 20 VDCW; sim to Sprague Type 150D.
C8	5490008P11	Silver mica: 22 pF + or - 5%, 500 VDCW, sim. to DM-15.
C9	5490008P39	Silver mica: 330 pF + or - 5%, 500 VDCW, sim. to DM-15.
C10 thru C12	19A116080P107	Polyester: 0.1 uF + or -10%, 50 VDCW.
C13	5496267P1	Tantalum: 6.8 uF + or - 20%, 6 VDCW; sim to Sprague Type 150D.
C14	19A116080P111	Polyester: 0.47 uF + or - 10%, 50 VDCW.
C15	5496267P9	Tantalum: 3.3 uF + or - 20%, 15 VDCW; sim to Sprague Type 150D.
C16 thru C20	19A700005P7	Polyester: 0.01 uF + or -10%, 50 VDCW.
C21 thru C23	19A116080P107	Polyester: 0.1 uF + or -10%, 50 VDCW.
C24	5496267P10	Tantalum: 22 uF + or - 20%, 15 VDCW; sim to Sprague Type 150D.
C25	19A700005P7	Polyester: 0.01 uF + or -10%, 50 VDCW.
C27 and C28	5494481P111	Ceramic disc: 1000 pF + or - 20%, 1000 VDCW; sim to RMC Type
----- DIODES -----		
CR1 thru CR5	19A115250P1	Silicon, fast recovery, 225 mA, 50 PIV.
CR6 and CR7	T324ADP1051	Silicon; 600 PRV, 1000 mA max; sim to 1N4005
----- PLUGS -----		
P1		(PART OF PWB 19D417216P1)
----- TRANSISTORS -----		
Q1 thru Q5	19A116774P1	Silicon, NPN; sim to Type 2N5210.
Q6	19A700023P1	Silicon, NPN: sim to 2N3904.
Q7	19A116774P1	Silicon, NPN; sim to Type 2N5210.
Q8 and Q9	19A700023P1	Silicon, NPN: sim to 2N3904.
Q10	19A115768P1	Silicon, PNP: sim to 2N3702.
Q11 thru Q13	19A700023P1	Silicon, NPN: sim to 2N3904.
Q14 thru Q16	19A116774P1	Silicon, NPN; sim to Type 2N5210.
----- RESISTORS -----		
R1	19A701250P417	Metal film: 147K ohms + or -1%, 1/4 w.

*COMPONENTS ADDED, DELETED OR CHANGED BY PRODUCTION CHANGES

SYMBOL	PART NO.	DESCRIPTION
R2	19A116278P93	Metal film: 90.9 ohms + or - 2%, 1/2 w.
R3	19A116559P110	Variable cermet: 50 ohms + or - 20%, 1/2 w; sim to CTS Series
R4	19A116278P501	Metal film: 1 MEG ohms + or - 2%, 1/2 w.
R5	19A116278P431	Metal film: 205K ohms + or - 2%, 1/2 w.
R6	19A116278P301	Metal film: 10K ohms + or - 2%, 1/2 w.
R7	19A116278P369	Metal film: 51.1K ohms + or - 2%, 1/2 w.
R8	19A116278P339	Metal film: 24.9K ohms + or - 2%, 1/2 w.
R9	19A116278P169	Metal film: 511 ohms + or - 2%, 1/2 w.
R10	19A116278P349	Metal film: 31.6K ohms + or - 2%, 1/2 w.
R11 thru R13	19A116278P301	Metal film: 10K ohms + or - 2%, 1/2 w.
R14	19A700106P73	Composition: 2.7K ohms + or - 5%, 1/4 w.
R15	3R152P623J	Composition: 62K ohms + or - 5%, 1/4 w.
R16	19A700106P89	Composition: 12K ohms + or - 5%, 1/4 w.
R17	3R152P242J	Composition: 2.4K ohms + or -5%, 1/4 w.
R18	19A700106P63	Composition: 1K ohms + or - 5%, 1/4 w.
R19	19A700106P87	Composition: 10K ohms + or - 5%, 1/4 w.
R20	3R152P334J	Composition: 0.33 megohms + or - 5%, 1/4 w.
R21	19A700106P91	Composition: 15K ohms + or - 5%, 1/4 w.
R22	19A700106P87	Composition: 10K ohms + or - 5%, 1/4 w.
R23	3R152P513J	Composition: 51K ohms + or - 5%, 1/4 w.
R24	3R152P242J	Composition: 2.4K ohms + or -5%, 1/4 w.
R25	3R152P511J	Composition: 510 ohms + or - 5%, 1/4 w.
R26	3R152P512J	Composition: 5.1K ohms + or -5%, 1/4 w.
R27	19A700106P101	Composition: 39K ohms + or -5%, 1/4 w.
R28	19A700106P67	Composition: 1.5K ohms + or - 5%, 1/4 w.
R30	19A700106P71	Composition: 2.2K ohms + or -5%, 1/4 w.
R31	19A700106P103	Composition: 47K ohms + or - 5%, 1/4 w.
R32	19A700106P111	Composition: 100K ohms + or - 5%, 1/4 w.
R33 and R34	3R152P154J	Composition: 150K ohms + or -5%, 1/4 w.
R35	19A700106P75	Composition: 3.3K ohms + or - 5%, 1/4 w.
R36	19A700106P39	Composition: 100 ohms + or - 5%, 1/4 w.
R37	3R152P203J	Composition: 20K ohms + or - 5%, 1/4 w.
R38	19A700106P57	Composition: 560 ohms + or - 5%, 1/4 w.
R39	19A700106P29	Composition: 39 ohms + or - 5%, 1/4 w.
R40	19A700106P99	Composition: 33K ohms + or - 5%, 1/4 w.
R41	3R152P300J	Composition: 30 ohms + or -5%, 1/4 w.
R42	19A700106P15	Composition: 10 ohms + or - 5%, 1/4 w.
----- TRANSFORMERS -----		
T1 and T2	19B219563G1	Coil.
----- TEST POINTS -----		
TP1	19B211379P1	Spring (Test Point).
----- VOLTAGE REGULATORS -----		
VR1	4036887P5	Silicon, zener: 5.4 Volts.

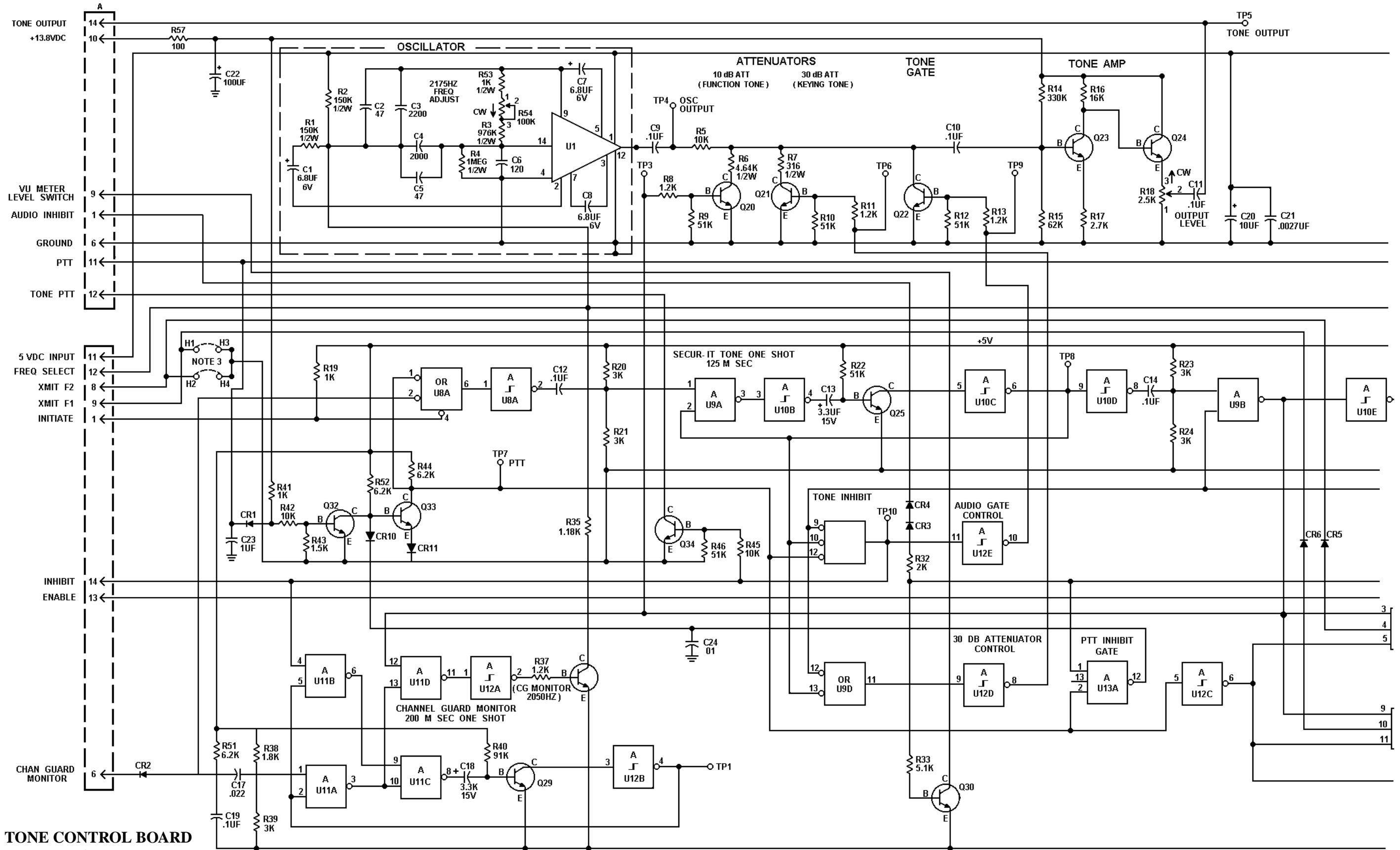

TONE CONTROL BOARD
19D417417G1

(19R622530, Rev. 7)

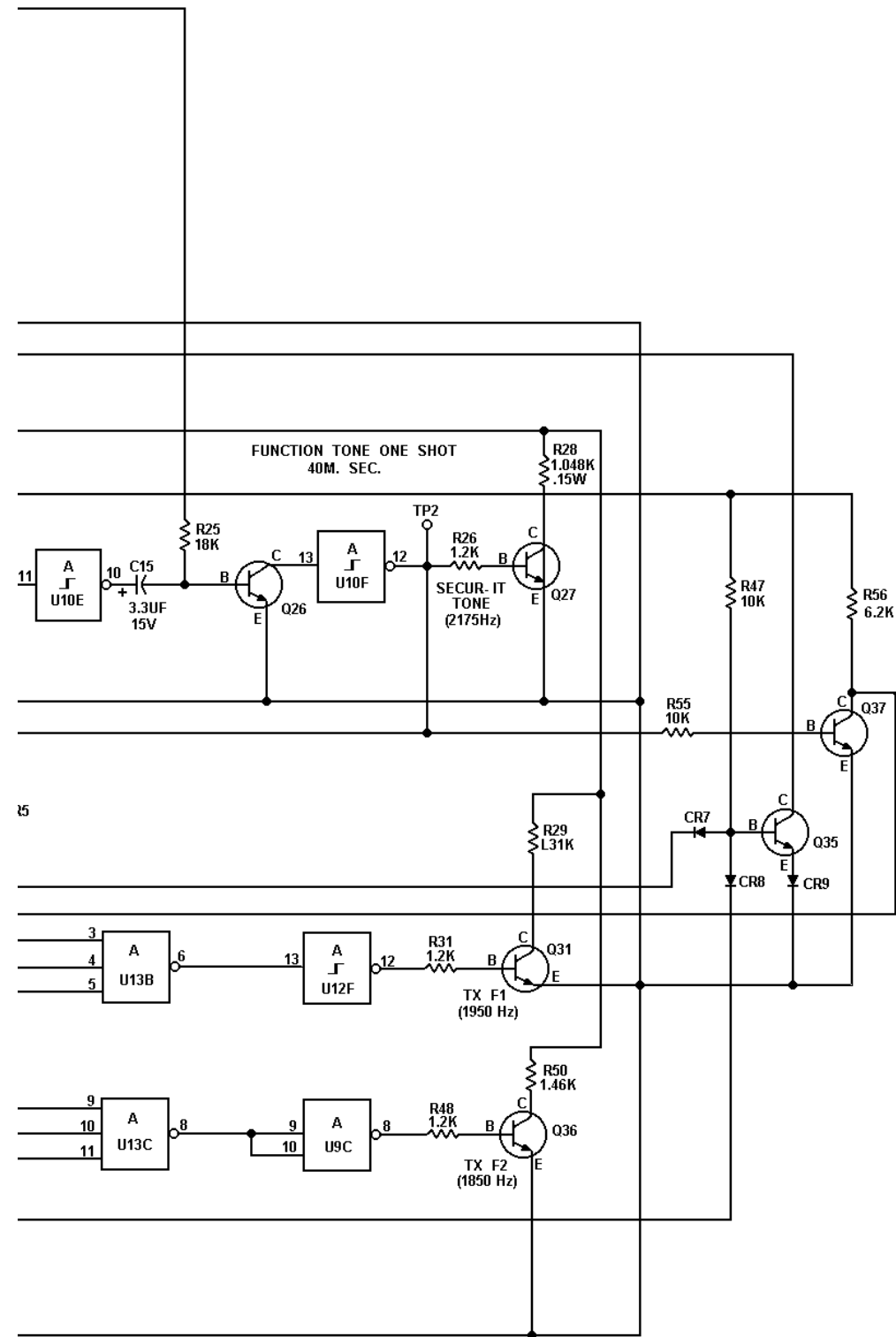

- NOTES:
1. +5VDC TO PIN 14 ON U8 THRU U13.
 2. GROUND TO PIN 7 ON U8 THRU U13
 3. MOVE DA JUMPER FROM H1 & H3 TO H2 & H4 FOR 1850HZ TRANSMIT FUNCTION TONE.

ALL RESISTORS ARE 1/4 WATT UNLESS OTHERWISE SPECIFIED AND RESISTOR VALUES IN OHMS UNLESS FOLLOWED BY K= 1000 OHMS OR MEG= 1,000,000 OHMS. CAPACITOR VALUES IN PICOFARADS (EQUAL TO MICROMICROFARADS) UNLESS FOLLOWED BY UF= MICROFARADS. INDUCTANCE VALUES IN MICROHENRYS UNLESS FOLLOWED BY MH= MILLIHENRYS OR H= HENRYS.

SEE APPLICABLE PRODUCTION CHANGE SHEETS IN INSTRUCTION BOOK SECTION DEALING WITH THIS UNIT, FOR DESCRIPTION OF CHANGES UNDER EACH REVISION LETTER.

THIS ELEM DIAG APPLIES TO

MODEL NO.	REV LETTER
PL19D417417G1	G

TONE CONTROL BOARD
19D417417G1
 ISSUE 6

SYMBOL	PART NO.	DESCRIPTION
A1		COMPONENT BOARD 19D417416G2
		----- CAPACITORS -----
C1	5496267P1	Tantalum: 6.8 uF + or - 20%, 6 VDCW; sim to Sprague Type 150D.
C2	5496219P855	Ceramic disc: 47 pF + or - 5%, 500 VDCW, temp coef -1500 PPM.
C3 and C4	5491871P2200E	Mica: 2200 pF + or - 1/2%, 300 VDCW; sim to DM-20.
C5	5496219P855	Ceramic disc: 47 pF + or - 5%, 500 VDCW, temp coef -1500 PPM.
C6	19A700105P36	Mica: 120 pF + or - 5%, 500 VDCW.
C7 and C8	5496267P1	Tantalum: 6.8 uF + or - 20%, 6 VDCW; sim to Sprague Type 150D.
C9 thru C12	19A116080P107	Polyester: 0.1 uF + or - 10%, 50 VDCW.
C13	5496267P409	Tantalum: 3.3 uF + or - 5%, 15 VDCW; sim to Sprague Type 150D.
C14	19A116080P107	Polyester: 0.1 uF + or - 10%, 50 VDCW.
C15	5496267P409	Tantalum: 3.3 uF + or - 5%, 15 VDCW; sim to Sprague Type 150D.
C17	T644ACP322K	Polyester: .022 uF + or - 10%, 50 VDCW.
C18	5496267P409	Tantalum: 3.3 uF + or - 5%, 15 VDCW; sim to Sprague Type 150D.
C19	19A116080P107	Polyester: 0.1 uF + or - 10%, 50 VDCW.
C20	19A115680P8	Electrolytic: 10 uF +150%-10%, 25 VDCW; sim to Mallory Type TTX.
C21	5494481P27	Ceramic disc: 2700 pF + or - 20%, 1000 VDCW; sim to RMC Type
C22	5496267P16	Tantalum: 100 uF + or - 20%, 20 VDCW; sim to Sprague Type 150D.
C23	19A701534P4	Tantalum: 1 uF + or - 20%, 35 VDCW.
C24	T644ACP310K	Polyester: .010 uF + or - 10%, 50 VDCW.
		----- DIODES -----
CR1 thru CR11	19A115250P1	Silicon, fast recovery, 225 mA, 50 PIV.
		----- TRANSISTORS -----
Q20 thru Q24	19A700023P1	Silicon, NPN: sim to 2N3904.
Q25 and Q26	19A116774P1	Silicon, NPN; sim to Type 2N5210.
Q27 thru Q37	19A700023P1	Silicon, NPN: sim to 2N3904.
		----- RESISTORS -----
R1 and R2	19A116278P418	Metal film: 150K ohms + or - 2%, 1/2 w.
R3	19A116278P496	Metal film: 976K ohms + or - 2%, 1/2 w.
R4	19A116278P501	Metal film: 1 MEG ohms + or - 2%, 1/2 w.
R5	19A700106P87	Composition: 10K ohms + or - 5%, 1/4 w.
R6	19A116278P265	Metal film: 4640 ohms + or - 2%, 1/2 w.
R7	19A116278P149	Metal film: 316 ohms + or - 2%, 1/2 w.
R8	19A700106P65	Composition: 1.2K ohms + or - 5%, 1/4 w.
R9 and R10	3R152P513J	Composition: 51K ohms + or - 5%, 1/4 w.

SYMBOL	PART NO.	DESCRIPTION
R11	19A700106P65	Composition: 1.2K ohms + or - 5%, 1/4 w.
R12	3R152P513J	Composition: 51K ohms + or - 5%, 1/4 w.
R13	19A700106P65	Composition: 1.2K ohms + or - 5%, 1/4 w.
R14	3R152P334J	Composition: 0.33 megohms + or - 5%, 1/4 w.
R15	3R152P623J	Composition: 62K ohms + or - 5%, 1/4 w.
R16	3R152P163J	Composition: 16K ohms + or - 5%, 1/4 w.
R17	19A700106P73	Composition: 2.7K ohms + or - 5%, 1/4 w.
R18	19B209358P104	Variable, carbon film: approx 50 to 2500 ohms + or - 10%, 1/4 w; sim to CTS Type X-201.
R19	H212CRP210C	Deposited carbon: 1K ohms + or - 5%, 1/4 w.
R20 and R21	3R152P302J	Composition: 3K ohms + or - 5%, 1/4 w.
R22	3R152P513J	Composition: 51K ohms + or - 5%, 1/4 w.
R23 and R24	3R152P302J	Composition: 3K ohms + or - 5%, 1/4 w.
R25	19A700106P93	Composition: 18K ohms + or - 5%, 1/4 w.
R26	19A700106P65	Composition: 1.2K ohms + or - 5%, 1/4 w.
R28	19A116690P1048	Wirewound: 1048 ohms + or - 0.1%, 0.15 w; sim MR-100-2A.
R29	19C314256P21311	Metal film: 1310 ohms + or - 1%, 1/4 w.
R31	19A700106P65	Composition: 1.2K ohms + or - 5%, 1/4 w.
R32	3R152P202J	Composition: 2K ohms + or - 5%, 1/4 w.
R33	3R152P512J	Composition: 5.1K ohms + or - 5%, 1/4 w.
R35	19A701250P208	Metal film: 1.18K ohms + or - 1%, 1/4 w.
R37	19A700106P65	Composition: 1.2K ohms + or - 5%, 1/4 w.
R38	19A700106P69	Composition: 1.8K ohms + or - 5%, 1/4 w.
R39	3R152P302J	Composition: 3K ohms + or - 5%, 1/4 w.
R40	3R152P913J	Composition: 91K ohms + or - 5%, 1/4 w.
R41	19A700106P63	Composition: 1K ohms + or - 5%, 1/4 w.
R42	19A700106P87	Composition: 10K ohms + or - 5%, 1/4 w.
R43	19A700106P67	Composition: 1.5K ohms + or - 5%, 1/4 w.
R44	3R152P622J	Composition: 6200 ohms + or - 5%, 1/4 w.
R45	19A700106P87	Composition: 10K ohms + or - 5%, 1/4 w.
R46	3R152P513J	Composition: 51K ohms + or - 5%, 1/4 w.
R47	19A700106P87	Composition: 10K ohms + or - 5%, 1/4 w.
R48	19A700106P65	Composition: 1.2K ohms + or - 5%, 1/4 w.
R50	19C314256P21461	Metal film: 1460 ohms + or - 1%, 1/4 w.
R51 and R52	3R152P622J	Composition: 6200 ohms + or - 5%, 1/4 w.
R53	19A116278P201	Metal film: 1000 ohms + or - 2%, 1/2 w.
R54	19A116559P129	Variable cermet: 100K ohms + or - 20%, 1/2 w; sim to CTS
R55	19A700106P87	Composition: 10K ohms + or - 5%, 1/4 w.
R56	3R152P622J	Composition: 6200 ohms + or - 5%, 1/4 w.
R57	19A700106P39	Composition: 100 ohms + or - 5%, 1/4 w.
		----- TEST POINTS -----
TP1 thru TP10	19B211379P1	Spring (Test Point).

SYMBOL	PART NO.	DESCRIPTION
		----- INTEGRATED CIRCUITS -----
U1	19D416410G1	Audio Stable Oscillator.
U8	19A700037P315	Digital: Dual 4-Input NAND gate; sim to 74LS20.
U9	19A700037P301	Digital: Quad 2-Input NAND gate; sim to 74LS00.
U10	19A700037P313	Digital: Hex Schmitt-Trigger Inverter; sim to 74LS14.
U11	19A700037P301	Digital: Quad 2-Input NAND gate; sim to 74LS00.
U12	19A700037P313	Digital: Hex Schmitt-Trigger Inverter; sim to 74LS14.
U13	19A700037P309	Digital: Triple 3-Input NAND gate; sim to 74LS10.
		----- MISCELLANEOUS -----
4	19B226184P1	Can: (Located over U1).
5	19B219690G1	Handle Assembly.

PRODUCTION CHANGES

Changes in the equipment to improve performance or to simplify circuits are identified by a "Revision Letter", which is stamped after the model number of the unit. The revision stamped on the unit includes all previous revisions. Refer to the Parts List for descriptions of parts affected by these revisions.

- REV. A - **19D417417G1**
To eliminate DTL Integrated Circuits. Changed printed wire board from 19D417416G1 to 19D417416G2.
- REV. B - **19D417417G1**
Added missing run between R2 and ±5v on printed board.
- REV. C - **19D417417G1**
To eliminate intermittent Channel Guard Monitor Function. Changed value of R38 and C17.
- REV. D - **19D417417G1**
To improve transistor saturation for Q25 and Q26. Changed to high gain transistors. Q25 and Q26 were - 19A700023P1.
- REV. E - **19D417417G1**
To allow setting oscillator frequency to 2175 Hz on some units. Changed R3. R3 was 19A116624P1 - Metal film: 1M ±0.1%, 1/2 w; sim to IRC Type CCA-T9.
- REV. F - **19D417417G1**
To improve Hex Inverters. Incorporated a schmitt trigger Hex Inverter. Changed U10 and U12. U10 was 19A700037P305 - Hex Inverter. U12 was 19A700037P305 - Hex Inverter.
- REV. G - **19D417417G1**
To permit adjustment to 2175 Hz due to component tolerance. R54 was 50K (19A116559P108).

LBI-4653

TONE CONTROL BOARD
19D417417G1

SYMBOL	PART NO.	DESCRIPTION
A1		COMPONENT BOARD 19D417416G1
		----- CAPACITORS -----
C1	5496267P1	Tantalum: 6.8 uF + or - 20%, 6 VDCW; sim to Sprague Type 150D.
C2	5496219P855	Ceramic disc: 47 pF + or - 5%, 500 VDCW, temp coef -1500 PPM.
C3 and C4	5491871P2200E	Mica: 2200 pF + or -1/2%, 300 VDCW; sim to DM-20.
C5	5496219P855	Ceramic disc: 47 pF + or -5%, 500 VDCW, temp coef -1500 PPM.
C6	19A700105P36	Mica: 120 pF + or -5%, 500 VDCW.
C7 and C8	5496267P1	Tantalum: 6.8 uF + or - 20%, 6 VDCW; sim to Sprague Type 150D.
C9 thru C12	19A116080P107	Polyester: 0.1 uF + or -10%, 50 VDCW.
C13	5496267P409	Tantalum: 3.3 uF + or - 5%, 15 VDCW; sim to Sprague Type 150D.
C14	19A116080P107	Polyester: 0.1 uF + or -10%, 50 VDCW.
C15	5496267P409	Tantalum: 3.3 uF + or - 5%, 15 VDCW; sim to Sprague Type 150D.
C16	19A116080P107	Polyester: 0.1 uF + or -10%, 50 VDCW.
C17	T644ACP322K	Polyester: .022 uF + or -10%, 50 VDCW.
C18	5496267P409	Tantalum: 3.3 uF + or - 5%, 15 VDCW; sim to Sprague Type 150D.
C19	19A116080P107	Polyester: 0.1 uF + or -10%, 50 VDCW.
C20	19A115680P8	Electrolytic: 10 uF +150%-10%, 25 VDCW; sim to Mallory Type TTX.
C21	5494481P27	Ceramic disc: 2700 pF + or - 20%, 1000 VDCW; sim to RMC Type
C22	5496267P16	Tantalum: 100 uF + or - 20%, 20 VDCW; sim to Sprague Type 150D.
		----- DIODES -----
CR1 thru CR9	19A115250P1	Silicon, fast recovery, 225 mA, 50 PIV.
		----- PLUGS -----
P1		(PART OF PWB 19D417412P1).
		----- TRANSISTORS -----
Q1 thru Q5	19A700023P1	Silicon, NPN: sim to 2N3904.
Q7 and Q8	19A700023P1	Silicon, NPN: sim to 2N3904.
Q9 and Q10	19A129207P1	Silicon, NPN.
Q11 and Q12	19A700023P1	Silicon, NPN: sim to 2N3904.
Q13	19A129207P1	Silicon, NPN.
Q14 thru Q17	19A700023P1	Silicon, NPN: sim to 2N3904.
Q18	19A129207P1	Silicon, NPN.
Q19	19A700023P1	Silicon, NPN: sim to 2N3904.

SYMBOL	PART NO.	DESCRIPTION
		----- RESISTORS -----
R1 and R2	19A116278P418	Metal film: 150K ohms + or - 2%, 1/2 w.
R3	19A116278P496	Metal film: 976K ohms + or -2%, 1/2 w.
R4	19A116278P501	Metal film: 1 MEG ohms + or - 2%, 1/2 w.
R5	19A700106P87	Composition: 10K ohms + or - 5%, 1/4 w.
R6	19A116278P265	Metal film: 4640 ohms + or - 2%, 1/2 w.
R7	19A116278P149	Metal film: 316 ohms + or - 2%, 1/2 w.
R8	19A700106P65	Composition: 1.2K ohms + or - 5%, 1/4 w.
R9 and R10	3R152P513J	Composition: 51K ohms + or - 5%, 1/4 w.
R11	19A700106P65	Composition: 1.2K ohms + or - 5%, 1/4 w.
R12	3R152P513J	Composition: 51K ohms + or - 5%, 1/4 w.
R13	19A700106P65	Composition: 1.2K ohms + or - 5%, 1/4 w.
R14	3R152P334J	Composition: 0.33 megohms + or - 5%, 1/4 w.
R15	3R152P623J	Composition: 62K ohms + or - 5%, 1/4 w.
R16	3R152P163J	Composition: 16K ohms + or - 5%, 1/4 w.
R17	19A700106P73	Composition: 2.7K ohms + or - 5%, 1/4 w.
R18	19B209358P104	Variable, carbon film: approx 50 to 2500 ohms + or - 10%, 1/4 w; sim to CTS Type X-201.
R20 and R21	3R152P302J	Composition: 3K ohms + or - 5%, 1/4 w.
R22	3R152P513J	Composition: 51K ohms + or - 5%, 1/4 w.
R23 and R24	3R152P302J	Composition: 3K ohms + or - 5%, 1/4 w.
R25	19A700106P93	Composition: 18K ohms + or - 5%, 1/4 w.
R26	19A700106P65	Composition: 1.2K ohms + or - 5%, 1/4 w.
R28	19A116690P1048	Wirewound: 1048 ohms + or - 0.1%, 0.15 w; sim MR-100-2A.
R29	19C314256P21311	Metal film: 1310 ohms + or - 1%, 1/4 w.
R31	19A700106P65	Composition: 1.2K ohms + or - 5%, 1/4 w.
R32	3R152P202J	Composition: 2K ohms + or - 5%, 1/4 w.
R33	3R152P512J	Composition: 5.1K ohms + or -5%, 1/4 w.
R35	19A701250P208	Metal film: 1.18K ohms + or - 1%, 1/4 w.
R37	19A700106P65	Composition: 1.2K ohms + or - 5%, 1/4 w.
R38	19A700106P69	Composition: 1.8K ohms + or - 5%, 1/4 w.
R39	3R152P302J	Composition: 3K ohms + or - 5%, 1/4 w.
R40	3R152P913J	Composition: 91K ohms + or - 5%, 1/4 w.
R41	19A700106P63	Composition: 1K ohms + or - 5%, 1/4 w.
R42	19A700106P87	Composition: 10K ohms + or - 5%, 1/4 w.
R43	19A700106P67	Composition: 1.5K ohms + or - 5%, 1/4 w.
R44	3R152P622J	Composition: 6200 ohms + or - 5%, 1/4 w.
R45	19A700106P87	Composition: 10K ohms + or - 5%, 1/4 w.
R46	3R152P513J	Composition: 51K ohms + or - 5%, 1/4 w.
R47	19A700106P87	Composition: 10K ohms + or - 5%, 1/4 w.
R48	19A700106P65	Composition: 1.2K ohms + or - 5%, 1/4 w.
R50	19C314256P21461	Metal film: 1460 ohms + or - 1%, 1/4 w.
R51 and R52	3R152P622J	Composition: 6200 ohms + or - 5%, 1/4 w.

SYMBOL	PART NO.	DESCRIPTION
R53	19A116278P201	Metal film: 1000 ohms + or - 2%, 1/2 w.
R54	19A116559P129	Variable cermet: 100K ohms + or - 20%, 1/2 w; sim to CTS
R55	19A700106P87	Composition: 10K ohms + or - 5%, 1/4 w.
R56	3R152P622J	Composition: 6200 ohms + or - 5%, 1/4 w.
R57	19A700106P39	Composition: 100 ohms + or - 5%, 1/4 w.
		----- TEST POINTS -----
TP1 thru TP10	19B211379P1	Spring (Test Point).
		----- INTEGRATED CIRCUITS -----
U1	19D416410G1	Audio Stable Oscillator.
U2	19A115913P1	Digital: Dual 4-Input Expandable NAND gate.
U3	19A116180P1	Digital: Quad 2-Input NAND Gate; sim to 7400.
U4	19A116180P20	Digital: Hex Inverter; sim to 7404.
U5	19A116180P1	Digital: Quad 2-Input NAND Gate; sim to 7400.
U6	19A116180P20	Digital: Hex Inverter; sim to 7404.
U7	19A115913P9	Digital: Triple 3-Input NAND gate; sim to 962.
		----- MISCELLANEOUS -----
	19B226184P1	Can.

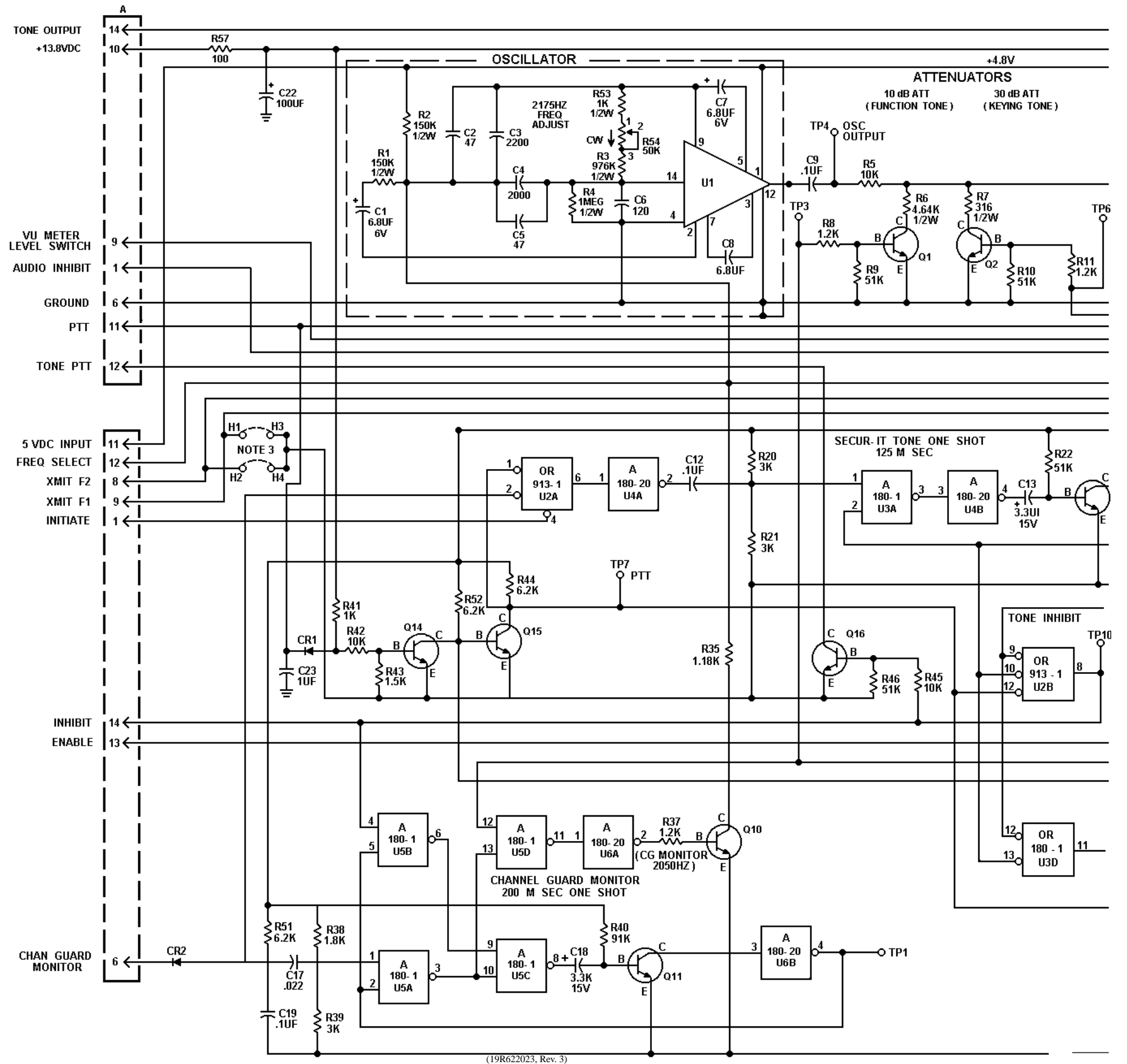

TONE CONTROL BOARD 19D417417G1
(USED IN EARLIER MODELS)

(19R622023, Rev. 3)

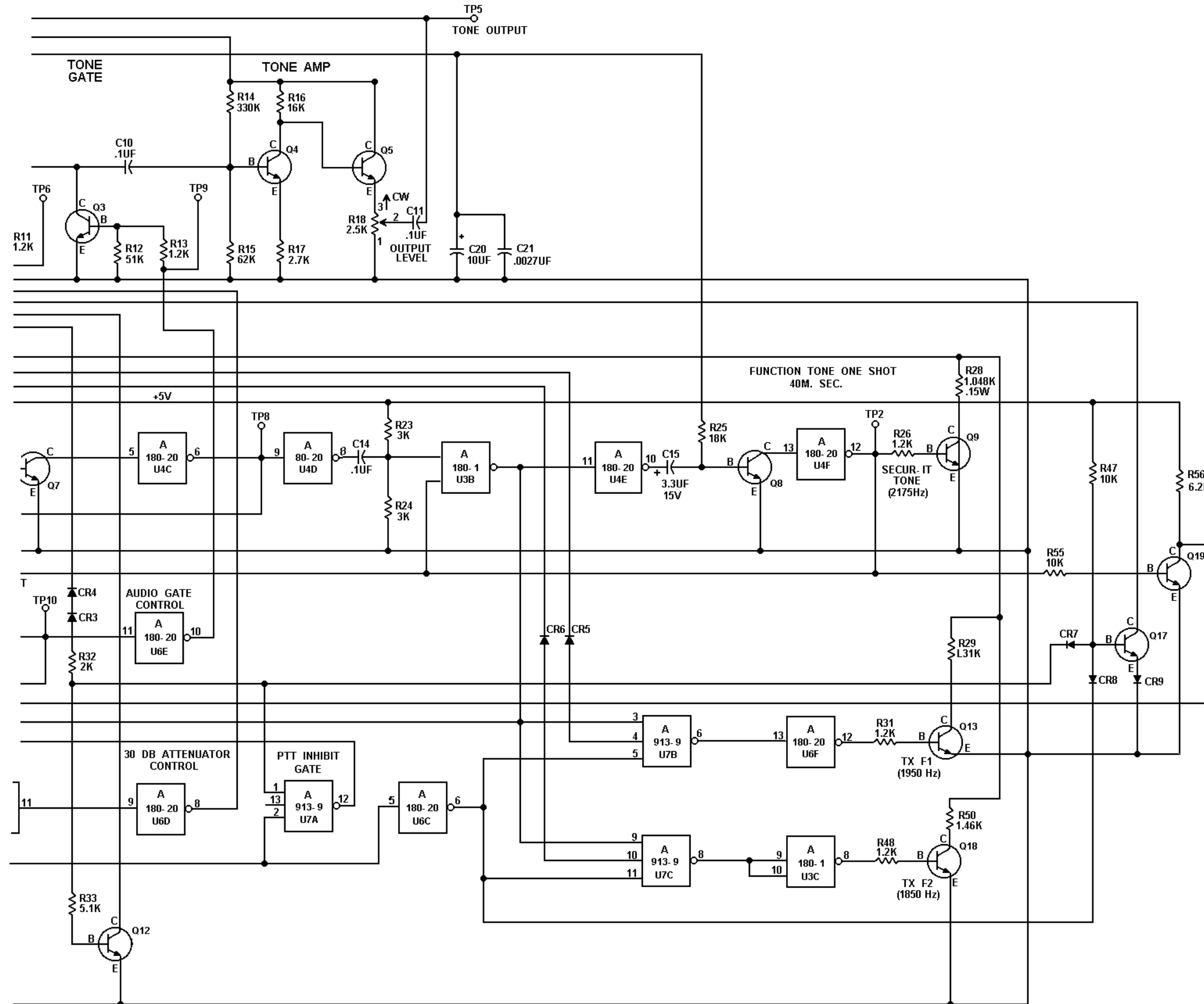

- NOTES:
1. +5VDC TO PIN 14 ON U2 THRU U7.
 2. GROUND TO PIN 7 ON U2 THRU U7.
 3. MOVE DA JUMPER FROM H1 & H3 TO H2 & H4 FOR 1850HZ TRANSMIT FUNCTION TONE.

ALL RESISTORS ARE 1/4 WATT UNLESS OTHERWISE SPECIFIED AND RESISTOR VALUES IN OHMS UNLESS FOLLOWED BY K= 1000 OHMS OR MEG= 1,000,000 OHMS. CAPACITOR VALUES IN PICOFARADS (EQUAL TO MICROMICROFARADS) UNLESS FOLLOWED BY UF= MICROFARADS, INDUCTANCE VALUES IN MICROHENRYS UNLESS FOLLOWED BY MH= MILLIHENRYS OR H= HENRYS.

SEE APPLICABLE PRODUCTION CHANGE SHEETS IN INSTRUCTION BOOK SECTION DEALING WITH THIS UNIT, FOR DESCRIPTION OF CHANGES UNDER EACH REVISION LETTER.	
THIS ELEM DIAG APPLIES TO	
MODEL NO.	REV LETTER
PL19D417417G1	E

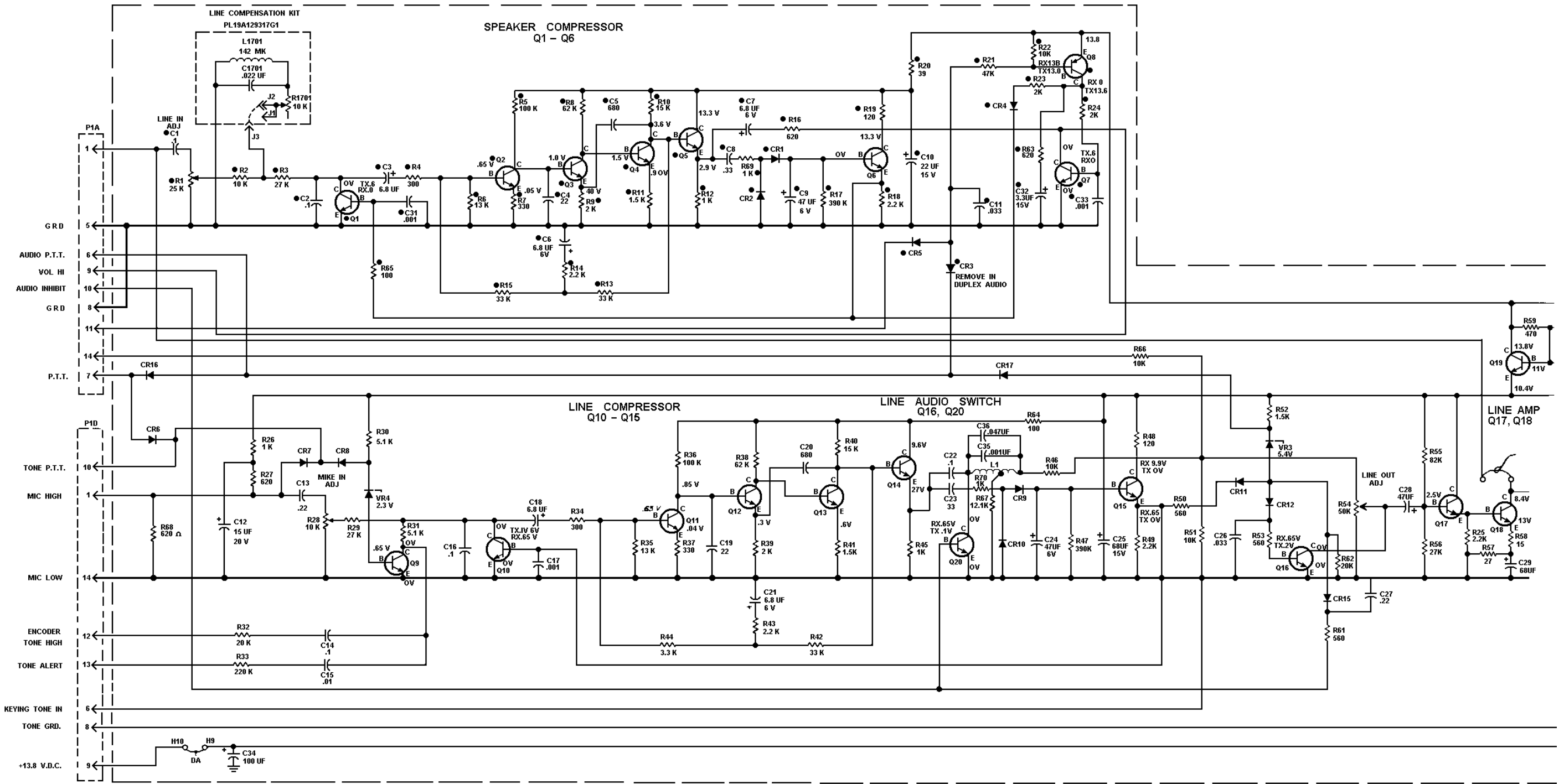

AUDIO BOARD 19D417432G1

(19R622021, Rev. 7)

- NOTES:
- FOR PARALLEL OPERATION, CLIP R60 FROM ALL UNITS BUT ONE.
 - PARTS
 - NOT PRESENT IN GROUP 2

IN ORDER TO RETAIN RATED EQUIPMENT PERFORMANCE, REPLACEMENT OF ANY SERVICE PART SHOULD BE MADE ONLY WITH A COMPONENT HAVING THE SPECIFICATIONS SHOWN ON THE PARTS LIST FOR THAT PART.

SEE APPLICABLE PRODUCTION CHANGE SHEETS IN INSTRUCTION BOOK SECTION DEALING WITH THIS UNIT, FOR DESCRIPTION OF CHANGES UNDER EACH REVISION LETTER.

THIS ELEM DIAG APPLIES TO	
MODEL NO.	REV LETTER
PL19D417432G1	E
PL19D417432G2	E

ALL RESISTORS ARE 1/4 WATT UNLESS OTHERWISE SPECIFIED AND RESISTOR VALUES IN OHMS UNLESS FOLLOWED BY K=1000 OHMS OR MEG=1,000,000 OHMS. CAPACITOR VALUES IN PICO FARADS (EQUAL TO MICROMICROFARADS) UNLESS FOLLOWED BY UF= MICROFARADS. INDUCTANCE VALUES IN MICROHENRYS UNLESS FOLLOWED BY MH= MILLIHENRYS OR H= HENRYS.

VOLTAGE READINGS

VOLTAGE READINGS ARE TYPICAL READINGS MEASURED TO SYSTEM GROUND WITH NO AUDIO INPUT SIGNAL FOR THE TRANSMIT CONDITION WHEN THE P.T.T. FUNCTION IS GROUNDED BOTH THE RECEIVE AND TRANSMIT VOLTAGE STATES ARE GIVEN WHERE DIFFERENT.

TX = PTT GROUNDED
RX = UNGROUNDED

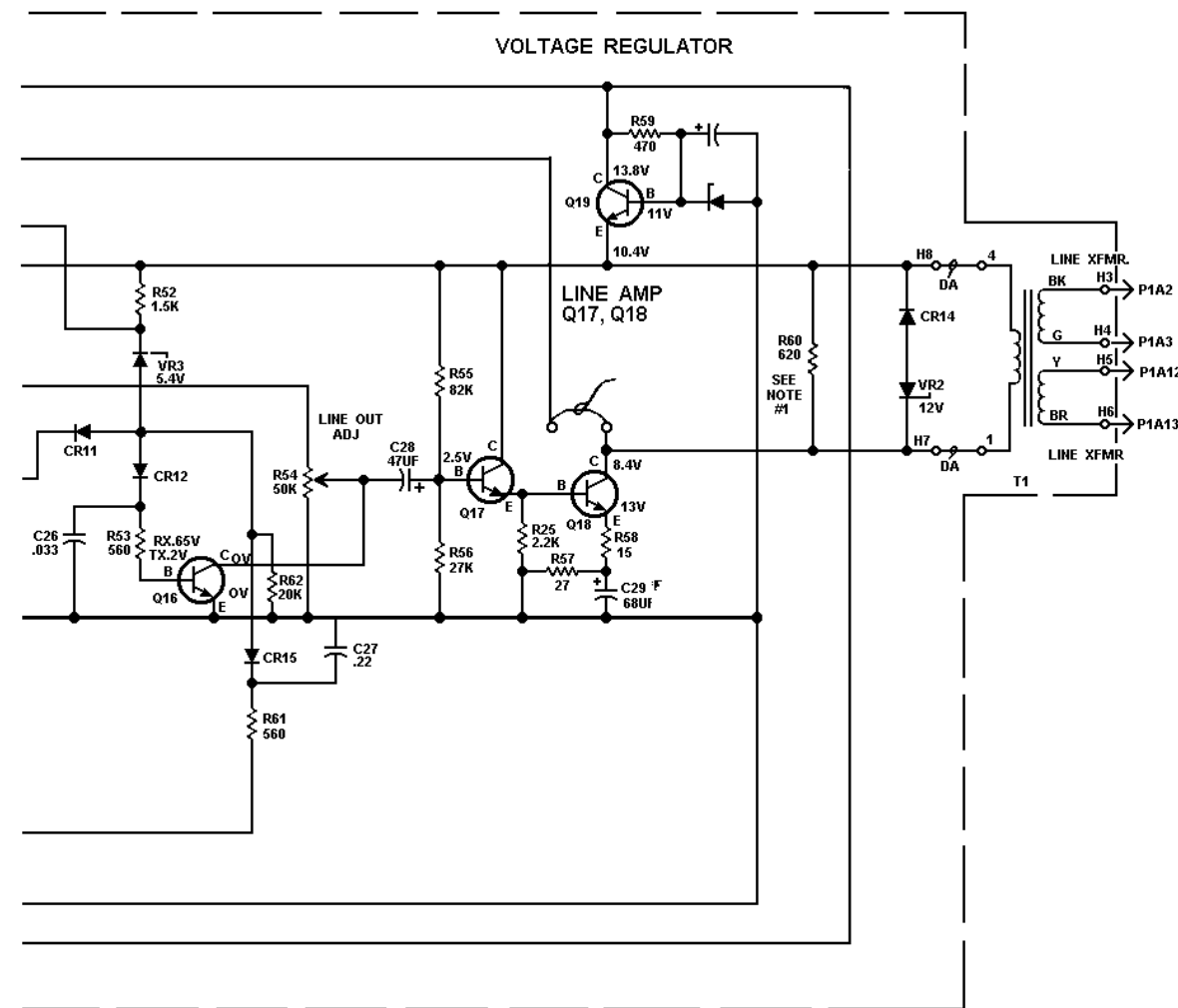

LBI4654D
AUDIO BOARD
19D417432G1, G2
REV. E

SYMBOL	PART NO.	DESCRIPTION
A1 A2		COMPONENT BOARD 19D417431G1 - G2 19D417431G2
		----- CAPACITORS -----
C1 and C2	19A116080P107	Polyester: 0.1 uF + or -10%, 50 VDCW.
C3	5496267P1	Tantalum: 6.8 uF + or - 20%, 6 VDCW; sim to Sprague Type 150D.
C4	7489162P11	Silver mica: 22 pF + or -5%, 500 VDCW; sim to Sprague Type 118.
C5	5494481P109	Ceramic disc: 680 pF + or - 20%, 1000 VDCW; sim to RMC Type
C6 and C7	5496267P1	Tantalum: 6.8 uF + or - 20%, 6 VDCW; sim to Sprague Type 150D.
C8	19A116080P110	Polyester: 0.33 uF + or -10%, 50 VDCW.
C9	5496267P2	Tantalum: 47 uF + or - 20%, 6 VDCW; sim to Sprague Type 150D.
C10	5496267P10	Tantalum: 22 uF + or - 20%, 15 VDCW; sim to Sprague Type 150D.
C11	19A700005P10	Polyester: 0.033 uF + or -10%, 50 VDCW.
C12	5496267P14	Tantalum: 15 uF + or - 20%, 20 VDCW; sim to Sprague Type 150D.
C13	19A116080P109	Polyester: 0.22 uF + or - 10%, 50 VDCW.
C14	19A116080P107	Polyester: 0.1 uF + or -10%, 50 VDCW.
C15	19A700005P7	Polyester: 0.01 uF + or -10%, 50 VDCW.
C16	19A116080P107	Polyester: 0.1 uF + or -10%, 50 VDCW.
C17	5494481P111	Ceramic disc: 1000 pF + or - 20%, 1000 VDCW; sim to RMC Type
C18	5496267P1	Tantalum: 6.8 uF + or - 20%, 6 VDCW; sim to Sprague Type 150D.
C19	7489162P11	Silver mica: 22 pF + or -5%, 500 VDCW; sim to Sprague Type 118.
C20	5494481P109	Ceramic disc: 680 pF + or - 20%, 1000 VDCW; sim to RMC Type
C21	5496267P1	Tantalum: 6.8 uF + or - 20%, 6 VDCW; sim to Sprague Type 150D.
C22	19A116080P107	Polyester: 0.1 uF + or -10%, 50 VDCW.
C23	19A116080P110	Polyester: 0.33 uF + or -10%, 50 VDCW.
C24	5496267P2	Tantalum: 47 uF + or - 20%, 6 VDCW; sim to Sprague Type 150D.
C25	5496267P11	Tantalum: 68 uF + or - 20%, 15 VDCW; sim to Sprague Type 150D.
C26	19A700005P10	Polyester: 0.033 uF + or -10%, 50 VDCW.
C27	19A116080P109	Polyester: 0.22 uF + or - 10%, 50 VDCW.
C28	5496267P2	Tantalum: 47 uF + or - 20%, 6 VDCW; sim to Sprague Type 150D.
C29	5496267P11	Tantalum: 68 uF + or - 20%, 15 VDCW; sim to Sprague Type 150D.
C30	5496267P10	Tantalum: 22 uF + or - 20%, 15 VDCW; sim to Sprague Type 150D.
C31	5494481P111	Ceramic disc: 1000 pF + or - 20%, 1000 VDCW; sim to RMC Type
C32	5496267P9	Tantalum: 3.3 uF + or - 20%, 15 VDCW; sim to Sprague Type 150D.
C33	5494481P111	Ceramic disc: 1000 pF + or - 20%, 1000 VDCW; sim to RMC Type
C34	5496267P16	Tantalum: 100 uF + or - 20%, 20 VDCW; sim to Sprague Type 150D.
C35	19C307114P4702G	Polystyrene: 47,000 pF + or -2%, 100 VDCW, temp. coef -120+30 PPM.

SYMBOL	PART NO.	DESCRIPTION
C36	5496203P481	Ceramic disc: 1000 pF + or - 10%, 500 VDCW, temp. coef -5600 PPM.
		----- DIODES -----
CR1 thru CR12	19A115250P1	Silicon, fast recovery, 225 mA, 50 PIV.
CR13 and CR14	T324ADP1051	Silicon; 600 PRV, 1000 mA max; sim to 1N4005
CR15 thru CR17	19A115250P1	Silicon, fast recovery, 225 mA, 50 PIV.
		----- JACKS -----
J1 thru J3		(Part of PWB 19A129927G1 on A1).
		----- INDUCTORS -----
L1	19B205354G8	Coil.
		----- PLUGS -----
P1		(Part of PWB 19A129972G1 on A1). (Part of PWB 19A129972G1 on A2).
		----- TRANSISTORS -----
Q1	19A129184P1	Silicon, NPN.
Q2 thru Q5	19A700023P1	Silicon, NPN: sim to 2N3904.
Q6	19A116774P1	Silicon, NPN; sim to Type 2N5210.
Q7	19A700023P1	Silicon, NPN: sim to 2N3904.
Q8	19A115768P1	Silicon, PNP: sim to 2N3702.
Q9	19A700023P1	Silicon, NPN: sim to 2N3904.
Q10	19A129184P1	Silicon, NPN.
Q11 thru Q14	19A700023P1	Silicon, NPN: sim to 2N3904.
Q15	19A116774P1	Silicon, NPN; sim to Type 2N5210.
Q16	19A700023P1	Silicon, NPN: sim to 2N3904.
Q17	19A116774P1	Silicon, NPN; sim to Type 2N5210.
Q18 and Q19	19A115300P4	Silicon, NPN.
Q20	19A700023P1	Silicon, NPN: sim to 2N3904.
		----- RESISTORS -----
R1	19B209358P107	Variable, carbon film: approx 800 to 25K ohms + or - 10%, 1/4 w; sim to CTS Type X-201.
R2	19A700106P87	Composition: 10K ohms + or - 5%, 1/4 w.
R3	19A700106P97	Composition: 27K ohms + or -5%, 1/4 w.
R4	3R152P301J	Composition: 300 ohms + or -5%, 1/4 w.
R5	19A700106P111	Composition: 100K ohms + or - 5%, 1/4 w.
R6	3R152P133J	Composition: 13K ohms + or -5%, 1/4 w.
R7	19A700106P51	Composition: 330 ohms + or - 5%, 1/4 w.
R8	3R152P623J	Composition: 62K ohms + or - 5%, 1/4 w.
R9	3R152P202J	Composition: 2K ohms + or - 5%, 1/4 w.
R10	19A700106P91	Composition: 15K ohms + or - 5%, 1/4 w.
R11	19A700106P67	Composition: 1.5K ohms + or - 5%, 1/4 w.
R12	19A700106P63	Composition: 1K ohms + or - 5%, 1/4 w.
R13	19A700106P99	Composition: 33K ohms + or - 5%, 1/4 w.

SYMBOL	PART NO.	DESCRIPTION
R14	19A700106P71	Composition: 2.2K ohms + or -5%, 1/4 w.
R15	19A700106P99	Composition: 33K ohms + or - 5%, 1/4 w.
R16	3R152P621J	Composition: 620 ohms + or - 5%, 1/4 w.
R17	3R152P394J	Composition: 390K ohms + or -5%, 1/4 w.
R18	19A700106P71	Composition: 2.2K ohms + or -5%, 1/4 w.
R19	19A700106P41	Composition: 120 ohms + or - 5%, 1/4 w.
R20	19A700106P29	Composition: 39 ohms + or - 5%, 1/4 w.
R21	19A700106P103	Composition: 47K ohms + or - 5%, 1/4 w.
R22	19A700106P87	Composition: 10K ohms + or - 5%, 1/4 w.
R23 and R24	3R152P202J	Composition: 2K ohms + or - 5%, 1/4 w.
R25	19A700106P71	Composition: 2.2K ohms + or -5%, 1/4 w.
R26	19A700106P63	Composition: 1K ohms + or - 5%, 1/4 w.
R27	3R152P621J	Composition: 620 ohms + or - 5%, 1/4 w.
R28	19B209358P106	Variable: 10K ohms + or -5; 1/4 w; sim to CTS X-201
R29	19A700106P97	Composition: 27K ohms + or -5%, 1/4 w.
R30 and R31	3R152P512J	Composition: 5.1K ohms + or -5%, 1/4 w.
R32	3R152P203J	Composition: 20K ohms + or - 5%, 1/4 w.
R33	3R152P224J	Composition: 220K ohms + or -5%, 1/4 w.
R34	3R152P301J	Composition: 300 ohms + or -5%, 1/4 w.
R35	3R152P133J	Composition: 13K ohms + or -5%, 1/4 w.
R36	19A700106P111	Composition: 100K ohms + or - 5%, 1/4 w.
R37	19A700106P51	Composition: 330 ohms + or - 5%, 1/4 w.
R38	3R152P623J	Composition: 62K ohms + or - 5%, 1/4 w.
R39	3R152P202J	Composition: 2K ohms + or - 5%, 1/4 w.
R40	19A700106P91	Composition: 15K ohms + or - 5%, 1/4 w.
R41	19A700106P67	Composition: 1.5K ohms + or - 5%, 1/4 w.
R42	19A700106P99	Composition: 33K ohms + or - 5%, 1/4 w.
R43	19A700106P71	Composition: 2.2K ohms + or -5%, 1/4 w.
R44	19A700106P99	Composition: 33K ohms + or - 5%, 1/4 w.
R45	19A700106P63	Composition: 1K ohms + or - 5%, 1/4 w.
R46	19A700106P87	Composition: 10K ohms + or - 5%, 1/4 w.
R47	3R152P394J	Composition: 390K ohms + or -5%, 1/4 w.
R48	19A700106P41	Composition: 120 ohms + or - 5%, 1/4 w.
R49	19A700106P71	Composition: 2.2K ohms + or -5%, 1/4 w.
R50	19A700106P57	Composition: 560 ohms + or - 5%, 1/4 w.

SYMBOL	PART NO.	DESCRIPTION
R51	19A700106P87	Composition: 10K ohms + or - 5%, 1/4 w.
R52	19A700106P67	Composition: 1.5K ohms + or - 5%, 1/4 w.
R53	19A700106P57	Composition: 560 ohms + or - 5%, 1/4 w.
R54	19B209358P108	Variable, carbon film: approx 2K to 50K ohms + or -10%, 1/4 w; sim to CTS Type X-201.
R55	19A700106P109	Composition: 82K ohms + or - 5%, 1/4 w.
R56	19A700106P97	Composition: 27K ohms + or -5%, 1/4 w.
R57	19A700106P25	Composition: 27 ohms + or - 5%, 1/4 w.
R58	19A700106P19	Composition: 15 ohms + or - 5%, 1/4 w.
R59	19A700106P55	Composition: 470 ohms + or - 5%, 1/4 w.
R60	3R152P621J	Composition: 620 ohms + or - 5%, 1/4 w.
R61	19A700106P57	Composition: 560 ohms + or - 5%, 1/4 w.
R62	3R152P203J	Composition: 20K ohms + or - 5%, 1/4 w.
R63	3R152P621J	Composition: 620 ohms + or - 5%, 1/4 w.
R64 and R65	19A700106P39	Composition: 100 ohms + or - 5%, 1/4 w.
R66	19A700106P87	Composition: 10K ohms + or - 5%, 1/4 w.
R67	19A701250P309	Metal film: 12.1K ohms + or -1%, 250 VDCW, 1/4 w.
R68	3R152P621J	Composition: 620 ohms + or - 5%, 1/4 w.
R69 and R70	H212CRP210C	Deposited carbon: 1K ohms + or -5%, 1/4 w.
		----- TRANSFORMERS -----
T1	19A115731P1	Audio: 300 - 6000 Hz; Pri (1-4): 22 ohms + or - Pri (2-3): 12.5 ohms + or - 15% DC 13 ohms + or - 15%, Sec 2: 13 ohms + or - 15%.
		----- VOLTAGE REGULATORS -----
VR1	4036887P8	Zener: 500 mW, 11 v. nominal.
VR2	19A116325P4	Zener: 5 w, 12 v; sim to Type 1N5349.
VR3	4036887P5	Silicon, zener: 5.4 Volts.
VR4	4036887P1	Silicon, zener: 2.3 Volts.
		----- MISCELLANEOUS -----
4	19A701332P4	Insulator, washer: nylon.
9	N80P13005B6	Machine screw, panhead: No. 6-32 x 5/16.
10	N404P13B6	Lockwasher, internal tooth: No. 6.
11	7141225P3	Hex Nut: No. 6-32.

PRODUCTION CHANGES

Changes in the equipment to improve performance or to simplify circuits are identified by a "Revision Letter", which is stamped after the model number of the unit. The revision stamped on the unit includes all previous revisions. Refer to the Parts List for descriptions of parts affected by these revisions.

- REV. A - **AUDIO BOARD 19D417432G1, G2**
To improve performance. Changed C29, Q1 and Q10.
- REV. B - To improve performance. Added 2175 Hz notch filter composed of C35, C36, R67 and L1.
- REV. C - To reduce remote keying input sensitivity to match voter output. Changed R29 from 3R152P133J to 19A700019P55 (33K ohms).
- REV. D - To match voter output, changed R29. R29 was 3R152P133J; Composition, 13K ohms ±5%, 1/4 Watt. New value of R29 is 27K ohms (19A700106P97).
- REV. E - To reduce distortion: Added R70.

*COMPONENTS ADDED, DELETED OR CHANGED BY PRODUCTION CHANGES

ALARM TONE BOARD

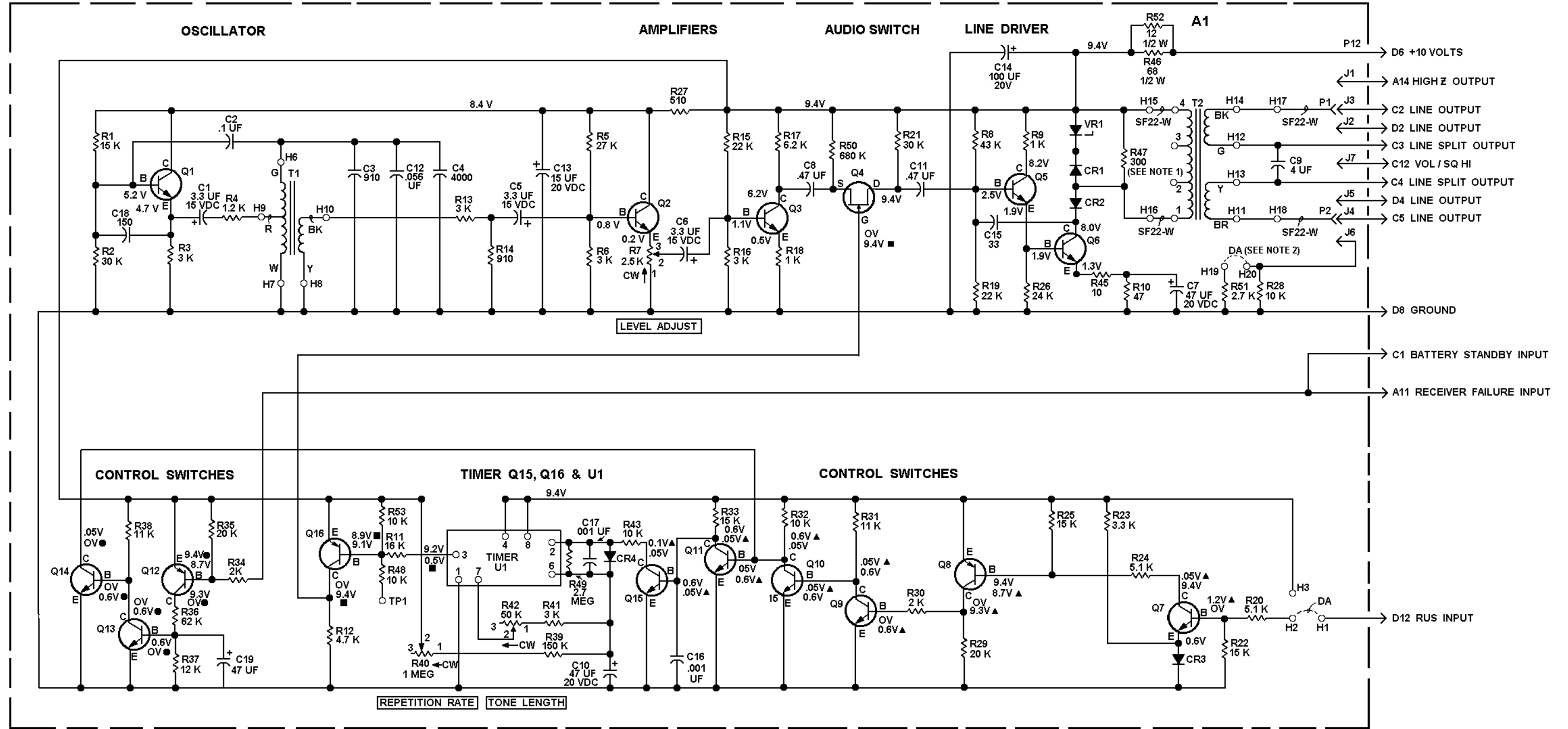

IN ORDER TO RETAIN RATED EQUIPMENT PERFORMANCE, REPLACEMENT OF ANY SERVICE PART SHOULD BE MADE ONLY WITH A COMPONENT HAVING THE SPECIFICATIONS SHOWN ON THE PARTS LIST FOR THAT PART.

ALL RESISTORS ARE 1/4 WATT UNLESS OTHERWISE SPECIFIED AND RESISTOR VALUES IN OHMS UNLESS FOLLOWED BY K=1000 OHMS OR MEG=1,000,000 OHMS. CAPACITOR VALUES IN PICOFARADS (EQUAL TO MICROMICROFARADS) UNLESS FOLLOWED BY UF=MICROFARADS. INDUCTANCE VALUES IN MICROHENRYS UNLESS FOLLOWED BY MH=MILLIHENRYS OR HENRYS.

SEE APPLICABLE PRODUCTION CHANGE SHEETS IN INSTRUCTION BOOK SECTION DEALING WITH THIS UNIT, FOR DESCRIPTION OF CHANGES UNDER EACH REVISION LETTER.

THIS ELEM DIAG APPLIES TO	
MODEL NO.	REV LETTER
19A130122G1	G

- NOTES:
1. REMOVE IN REMOTE / REPEAT, REPEAT OR LOCAL REPEAT COMBINATIONS.
 2. ADD JUMPER FROM H19 TO H20 IN LOCAL CONTROL COMBINATIONS.

VOLTAGE READINGS MEASURED WITH NO AC SIGNAL APPLIED

- ▲ RUS INPUT HIGH
- BATTERY STANDBY HIGH
- ALARM TONE ON

(19D417610, Rev. 10)

TONE FAILURE BOARD
19A130122G1

LBI4655E

TONE FAILURE BOARD
19DA130122G1 - REV G

SYMBOL	PART NO.	DESCRIPTION
A1		COMPONENT BOARD 19C320965G1
----- CAPACITORS -----		
C1	5496267P9	Tantalum: 3.3 uF + or - 20%, 15 VDCW; sim to Sprague Type 150D.
C2	19A116080P107	Polyester: 0.1 uF + or - 10%, 50 VDCW.
C3	5496372P379	Ceramic disc: 910 pF + or - 10%, 500 VDCW, temp coef -4700 PPM.
C4	5496249P4000G	Polystyrene: 4000 pF + or - 2 1/2%, 125 VDCW.
C5 and C6	5496267P9	Tantalum: 3.3 uF + or - 20%, 15 VDCW; sim to Sprague Type 150D.
C7	5496267P15	Tantalum: 47 uF + or - 20%, 20 VDCW; sim to Sprague Type 150D.
C8	19A116080P111	Polyester: 0.47 uF + or - 10%, 50 VDCW.
C9	7486445P5	Electrolytic, non polarized: 4 uf -10 + 100%, 150 VDCW.
C10	5496267P15	Tantalum: 47 uF + or - 20%, 20 VDCW; sim to Sprague Type 150D.
C11	19A116080P111	Polyester: 0.47 uF + or - 10%, 50 VDCW.
C12	19C307114P5602G	Polystyrene: 56,000 pF + or - 2%, 100 VDCW, temp. coef -120+30 PPM/oC.
C13	5496267P14	Tantalum: 15 uF + or - 20%, 20 VDCW; sim to Sprague Type 150D.
C14	5496267P16	Tantalum: 100 uF + or - 20%, 20 VDCW; sim to Sprague Type 150D.
C15	7489162P15	Silver mica: 33 pF + or - 5%, 500 VDCW; sim to Sprague Type 118.
C16 and C17	19A116655P19	Ceramic disc: 1000 pF + or - 20%, 1000 VDCW; sim to RMC
C18	5494481P101	Ceramic disc: 150 pF + or - 20%, 1000 VDCW; sim to RMC Type
C19	19A134202P2	Tantalum: 47 uF + or -20%, 6 VDCW.
----- DIODES -----		
CR1 and CR2	T324ADP1061	Silicon; 800 PRV, 1000 mA max; sim to 1N4006
CR3 and CR4	19A115250P1	Silicon, fast recovery, 225 mA, 50 PIV.
----- JACKS -----		
J1 thru J7	4033513P4	Contact, electrical: sim to Bead Chain L93-3.
----- PLUGS -----		
P1	19A702402P1	Contact, electrical: sim to AMP 41854.
P2	19A702402P2	Contact, electrical; sim to AMP 42827-2.
P12		(Part of PWB 19D417600A).
----- TRANSISTORS -----		
Q1 thru Q3	19A700023P1	Silicon, NPN: sim to 2N3904.
Q4	19A134137P4	N Type, field effect; sim to Type 2N3458.
Q5	19A700023P1	Silicon, NPN: sim to 2N3904.
Q6	19A115300P4	Silicon, NPN.
Q7	19A700023P1	Silicon, NPN: sim to 2N3904.
Q8	19A700022P1	Silicon, PNP: sim to 2N3906.

SYMBOL	PART NO.	DESCRIPTION
Q9 thru Q11	19A700023P1	Silicon, NPN: sim to 2N3904.
Q12	19A700022P1	Silicon, PNP: sim to 2N3906.
Q13 thru Q15	19A700023P1	Silicon, NPN: sim to 2N3904.
Q16	19A700022P1	Silicon, PNP: sim to 2N3906.
----- RESISTORS -----		
R1	19A700106P91	Composition: 15K ohms + or - 5%, 1/4 w.
R2	3R152P303J	Composition: 30K ohms + or - 5%, 1/4 w.
R3	3R152P302J	Composition: 3K ohms + or - 5%, 1/4 w.
R4	19A700106P65	Composition: 1.2K ohms + or - 5%, 1/4 w.
R5	19A700106P97	Composition: 27K ohms + or -5%, 1/4 w.
R6	3R152P302J	Composition: 3K ohms + or - 5%, 1/4 w.
R7	19B209358P104	Variable, carbon film: approx 50 to 2500 ohms + or - 10%, 1/4 w; sim to CTS Type X-201.
R8	3R152P433J	Composition: 43K ohms + or -5%, 1/4 w.
R9	19A700106P63	Composition: 1K ohms + or - 5%, 1/4 w.
R10	19A700106P31	Composition: 47 ohms + or - 5%, 1/4 w.
R11	3R152P163J	Composition: 16K ohms + or - 5%, 1/4 w.
R12	19A700106P79	Composition: 4.7K ohms + or -5%, 1/4 w.
R13	3R152P302J	Composition: 3K ohms + or - 5%, 1/4 w.
R14	3R152P911J	Composition: 910 ohms + or -5%, 1/4 w.
R15	19A700106P95	Composition: 22K ohms + or - 5%, 1/4 w.
R16	3R152P302J	Composition: 3K ohms + or - 5%, 1/4 w.
R17	3R152P622J	Composition: 6200 ohms + or - 5%, 1/4 w.
R18	19A700106P63	Composition: 1K ohms + or - 5%, 1/4 w.
R19	19A700106P95	Composition: 22K ohms + or - 5%, 1/4 w.
R20	3R152P512J	Composition: 5.1K ohms + or -5%, 1/4 w.
R21	3R152P303J	Composition: 30K ohms + or - 5%, 1/4 w.
R22	19A700106P91	Composition: 15K ohms + or - 5%, 1/4 w.
R23	19A700106P75	Composition: 3.3K ohms + or - 5%, 1/4 w.
R24	3R152P512J	Composition: 5.1K ohms + or -5%, 1/4 w.
R25	19A700106P91	Composition: 15K ohms + or - 5%, 1/4 w.
R26	3R152P243J	Composition: 24K ohms + or -5%, 1/4 w.
R27	3R152P511J	Composition: 510 ohms + or - 5%, 1/4 w.
R28	19A700106P87	Composition: 10K ohms + or - 5%, 1/4 w.
R29	3R152P203J	Composition: 20K ohms + or - 5%, 1/4 w.
R30	3R152P202J	Composition: 2K ohms + or - 5%, 1/4 w.
R31	3R152P113J	Composition: 11K ohms + or -5%, 1/4 w.
R32	19A700106P87	Composition: 10K ohms + or - 5%, 1/4 w.
R33	19A700106P91	Composition: 15K ohms + or - 5%, 1/4 w.
R34	3R152P202J	Composition: 2K ohms + or - 5%, 1/4 w.
R35	3R152P203J	Composition: 20K ohms + or - 5%, 1/4 w.
R36	3R152P623J	Composition: 62K ohms + or - 5%, 1/4 w.
R37	19A700106P89	Composition: 12K ohms + or - 5%, 1/4 w.
R38	3R152P113J	Composition: 11K ohms + or -5%, 1/4 w.
R39	3R152P154J	Composition: 150K ohms + or -5%, 1/4 w.
R40	19B209358P112	Variable, carbon film: approx 2000 to 1 megohm + or -20%, 1/4 w; sim to CTS Type X-201.
R41	3R152P302J	Composition: 3K ohms + or - 5%, 1/4 w.

SYMBOL	PART NO.	DESCRIPTION
R42	19B209358P108	Variable, carbon film: approx 2K to 50K ohms + or -10%, 1/4 w; sim to CTS Type X-201.
R43	19A700106P87	Composition: 10K ohms + or - 5%, 1/4 w.
R45	19A700106P15	Composition: 10 ohms + or - 5%, 1/4 w.
R46	19A700113P35	Composition: 68 ohms + or - 5%, 1/2 w.
R47	3R152P301J	Composition: 300 ohms + or -5%, 1/4 w.
R48	19A700106P87	Composition: 10K ohms + or - 5%, 1/4 w.
R49	3R152P275J	Composition: 2700K ohms + or - 5%, 1/4 w.
R50	3R152P684J	Composition: 680K ohms + or -5%, 1/4 w.
R51	19A700106P73	Composition: 2.7K ohms + or - 5%, 1/4 w.
R52	19A700113P17	Composition: 12 ohms + or - 5%, 1/2 w.
R53	19A700106P87	Composition: 10K ohms + or - 5%, 1/4 w.
----- TRANSFORMERS -----		
T1	19B205360G5	COIL
T2	19A115731P1	Audio: 300 - 6000 Hz; Pri (1-4): 22 ohms + or - Pri (2-3): 12.5 ohms + or - 15% DC 13 ohms + or - 15%, Sec 2: 13 ohms + or - 15%.
----- TEST POINTS -----		
TP1	19B211379P1	Spring (Test Point).
----- INTEGRATED CIRCUITS -----		
U1	19A116968P1	Linear: Timer; sim to Signetics SA555N.
----- VOLTAGE REGULATORS -----		
VR1	19A116325P4	Zener: 5 w, 12 v; sim to Type 1N5349.
----- MISCELLANEOUS -----		
3	19A701332P4	Insulator, washer: nylon (used with Q6).
6	19A121175P13	Insulator, plate (used with C9).
7	N80P13006B6	Machine screw: Pan head, Phillips; No. 8-32 x 3/8"
8	N404P13B6	Lockwasher, internal tooth: No. 6.
9	7141225P3	Hex Nut: No. 6-32.

PRODUCTION CHANGES

Changes in the equipment to improve performance or to simplify circuits are identified by a "Revision Letter", which is stamped after the model number of the unit. The revision stamped on the unit includes all previous revisions. Refer to the Parts List for descriptions of parts affected by these revisions.

- REV. A - To improve performance. Changed R49.
- REV. B - To insure alarm tone operation when the transmitter is keyed. Added C16 and C17.
- REV. C - To prevent output of tone all the time and to improve audio switch. Added C18 and R50.
- REV. D - To increase alarm tone output in Local Control Stations. Added R51.
- REV. E - To improve freq. response of Voting Selector when used with Tone Failure Board. Changed C15 & R46 and added R52.
- REV. F - To stop tone output due to Q16 being biased off, too close to threshold and to prevent tone output, without a receiver failure. Added R53 and deleted R44.
- REV. G - To prevent a line failure tone when receiving the status tone for more than 15 seconds. Changed R36 & R37 and added C19.

*COMPONENTS ADDED, DELETED OR CHANGED BY PRODUCTION CHANGES

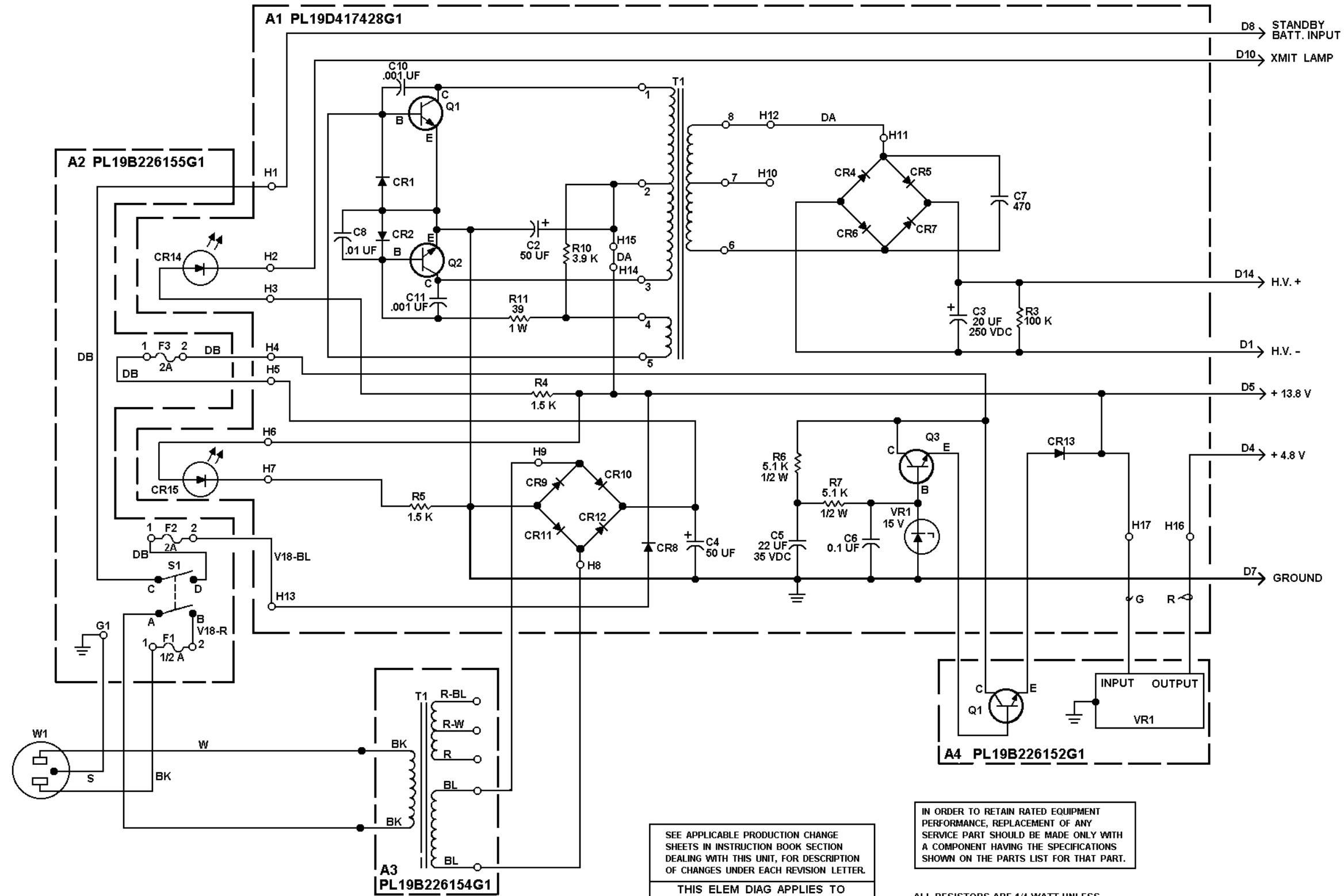

- NOTES:
1. FOR 70 VDC OPERATION MOVE DA JUMPER BETWEEN H11 & H12 TO H11 & H10.
 2. FOR TONE CONTROL SYSTEM REMOVE DA JUMPER BETWEEN H14 & H15.

SEE APPLICABLE PRODUCTION CHANGE SHEETS IN INSTRUCTION BOOK SECTION DEALING WITH THIS UNIT, FOR DESCRIPTION OF CHANGES UNDER EACH REVISION LETTER.

THIS ELEM DIAG APPLIES TO	
MODEL NO.	REV LETTER
PL19D417430G1	F

IN ORDER TO RETAIN RATED EQUIPMENT PERFORMANCE, REPLACEMENT OF ANY SERVICE PART SHOULD BE MADE ONLY WITH A COMPONENT HAVING THE SPECIFICATIONS SHOWN ON THE PARTS LIST FOR THAT PART.

ALL RESISTORS ARE 1/4 WATT UNLESS OTHERWISE SPECIFIED AND RESISTOR VALUES IN OHMS UNLESS FOLLOWED BY K=1000 OHMS OR MEG=1,000,000 OHMS. CAPACITOR VALUES IN PICO FARADS (EQUAL TO MICROMICROFARADS) UNLESS FOLLOWED BY UF=MICROFARADS. INDUCTANCE VALUES IN MICROHENRYS UNLESS FOLLOWED BY MH=MILLIHENRYS OR HENRYS.

(19D417419, Rev. 10)

LBI-4656D
POWER SUPPLY MODULE
19D417430G1 - REV. F

SYMBOL	PART NUMBER	DESCRIPTION
A1		RECTIFIER BOARD 19D417428G1
		----CAPACITORS----
C1*	5496267P16	Tantalum: 100µF ±20%, 20 VDCW: sim. to Sprague Type 150D.
C2	19A115680P4	Electrolytic: 50µF +150%, - 10%, 25 VDCW: sim. to Mallory Type TTX.
C3	5493132P16	Electrolytic: 20µF -10 +50%, 250 VDCW.
C4	19A116640P1	Electrolytic: 1600µF +150% -10%, 50 VDCW.
C5*	5496267P19	Tantalum: 22µF ±20%, 35 VDCW: sim. to Sprague Type 150D.
	5496267P10	Tantalum: 22µF ±20%, 15 VDCW: sim. to Sprague Type 150D.
C6	19A116080P107	Polyester: 0.1µF ±10%, 50 VDCW.
C7	5494481P7	Ceramic disc: 470pF ±10%, 100 VDCW: to RMC Type JFDiscap.
C8*	19A700005P7	Polyester: 0.01µF ±10%, 50 VDCW.
C9*	19A700005P7	Polyester: 0.01µF ±10%, 50 VDCW.
C10* and C11*	19A116655P1	Ceramic disc: 1000pF ±20%, 1000 VDCW: sim. to RMC Type JFDiscap.
		DIODES AND ----RECTIFIERS----
CR1 and CR2 C3*	19A704142P2	Silicon, General Purpose: sim. To 1N4005.
CR4 thru CR13 CR14 and CR15	4037822P1	Silicon: 1000mA, 400V PIV.
	19A704142P2	Silicon, General Purpose: sim. To 1N4005.
	19A134354P6	Diode: Optoelectronics: Red: sim. to HP 5082- 4650.
		----PLUGS----
		(Part of printed circuit board 19D417418P1)

* COMPONENTS ADDED, DELETED OR CHANGED BY
PRODUCTION CHANGES

SYMBOL	PART NUMBER	DESCRIPTION
		----TRANSISTORS----
Q1* and Q2*	19A115300P4	Silicon, NPN.
	19A115300P2	Silicon, NPN: sim. to Type 2N3053.
Q3	19A115300P2	Silicon, NPN: sim. to Type 2N3053.
		----RESISTORS----
R3	19A700106P111	Composition: 100k Ohms ±5%, 1/4 Watt.
R4 and R5	19A700106P67	Composition: 1.5k Ohms ±5%, 1/4 Watt.
R6 and R7	3R77P512J	Composition: 5.1k Ohms ±5%, 1/4 Watt.
R8*	3R152P511J	Composition: 510 Ohms ±5%, 1/4 Watt.
R9*	19A700106P32	Composition: 51 Ohms ±5%, 1/4 Watt.
R10*	3R152P392J	Composition: 3.9k Ohms ±5%, 1/4 Watt.
R11*	19A700112P19	Composition: 39 Ohms ±5%, 1/4 Watt.
		----TRANSFORMERS----
T1	19C303894G3	Coil assembly
		VOLTAGE ----REGULATORS----
VR1	4036887P12	Zener: 500 mW, 15V
VR2*	4036887P5	Zener: 500 mW, 3.4V
A2		SWITCH AND FUSE PANEL 19B226155G1
		----FUSES----
F1	7487942P3	Cartridge, glow blow: 1/2 amps @ 250V: sim. to Bussmann MDL. 1/2.
F2 and F3	1R16P5	Quick blowing: 2 Amp @ 250V: sim. to Littelfuse312002 or Bussmann AGC-2.
		----SWITCH----
S1	549L899P2	Toggle: DPST, 3 Amps @ 250V: sim. to Cutler- Hammer H370K8.
		----SOCKETS----
XF1 thru XF3	19B209005P1	Fuseholder: 15 Amps @ 250 V: sim. to Littelfuse 342012.
A3		POWER TRANSFORMER BOARD 19B226154G1
		----TRANSFORMER----
T1	19A118743P1	Power, step-down: <u>Primary</u> : 120Vrms, 50/60 Hz. <u>Secondary</u> : 24 Vdc ±4% @ 1 Amp.

SYMBOL	PART NUMBER	DESCRIPTION
A4		REGULATOR HEAT SINK 19B226152G1
		----TRANSISTORS----
Q1	19A116742P1	Silicon, NPN: sim. to Type 2N6103.
Q2*	19A116118P1	Silicon, NPN.
		VOLTAGE ----REGULATOR----
VR1	19A116834P1	Linear: 5V regulator: sim. to Microamp 209K.
		----CABLES----
W1	19A134587P1	Power, 3-wire, 13 amps @ 125 VAC, approximately 6 ft. long.
		----MISCELLANEOUS----
	19A701332P4	Insulator, washer: nylon,
	19B226137G1	Plate
	19A116022P1	Insulator, bushing
	19A116023P1	Insulator, plate

PRODUCTION CHANGES

Changes in the equipment to improve performance or to simplify circuits are identified by a "Revision Letter", which is stamped after the model number of the unit. The revision stamped on the unit includes all previous revisions. Refer to the Parts List for descriptions of parts affected by these revisions.

REV. A - To reduce voltage stress on Q1 & Q2. Deleted C1, C3, R1, R2 and R9. Added R10 and R11. Changed Q1 and Q2.

REV. B - To improve regulator output. Deleted Q2, R8 and VR2. Added C8 and 19A116834P1 IC regulator.

REV. C - Changed value of C5 to higher voltage rating.

REV. D - To eliminate high frequency oscillation, added C9 across transformer primary.

REV. E - To improve starting characteristics of 150-Volt multivibrator. Deleted C9. Added C10 and C11.

REV. F - To comply with Canadian standards changed wiring on primary side of transformer and added External Tooth Lockwashers to both sides of Ac ground terminal (Green).

REV. G - To change an aluminum electrolytic capacitor no longer available from the vendor. Changed capacitor C4 from 19A116640P1 to RJEUA 320 3505/22.

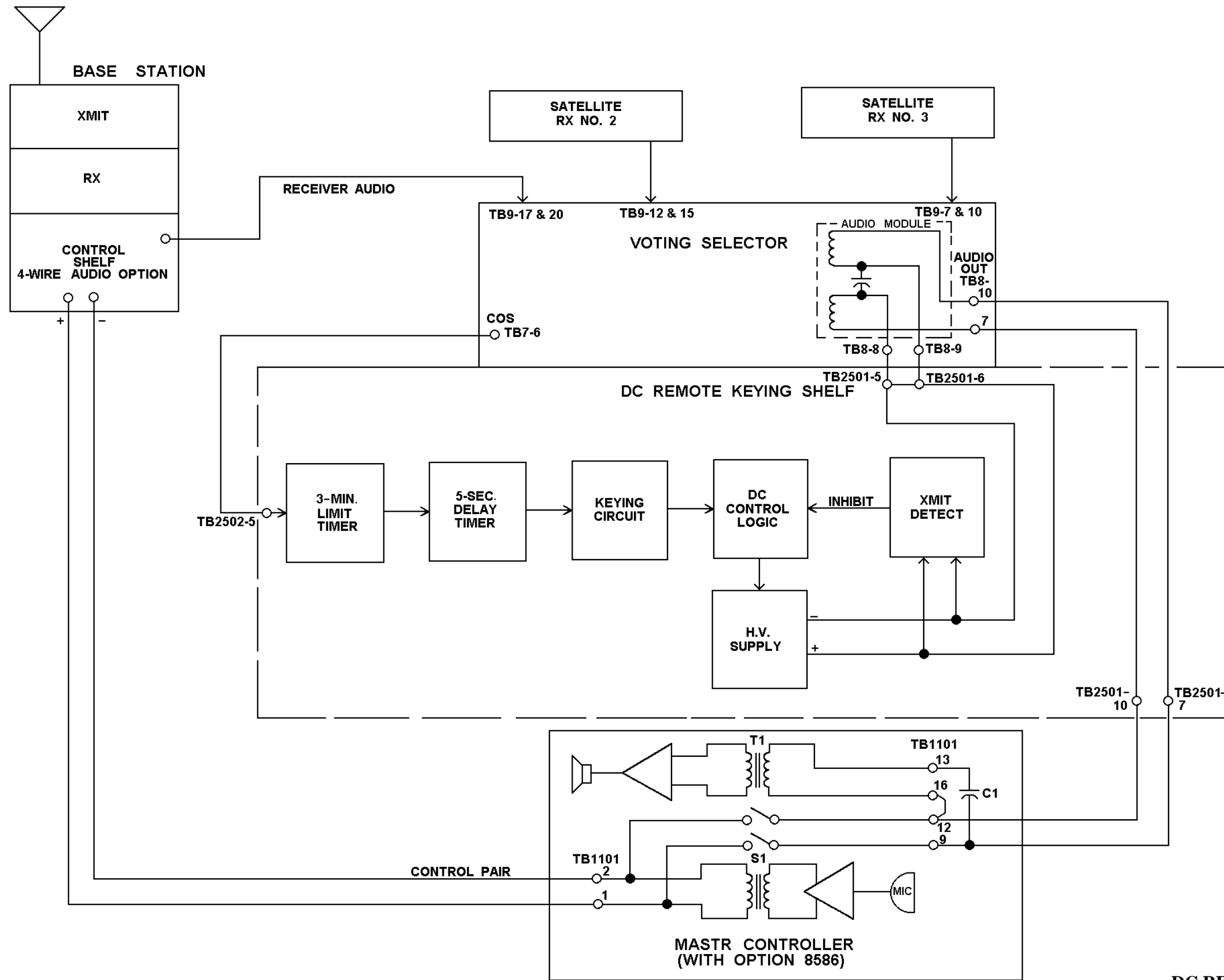

DC REMOTE KEYING SYSTEM

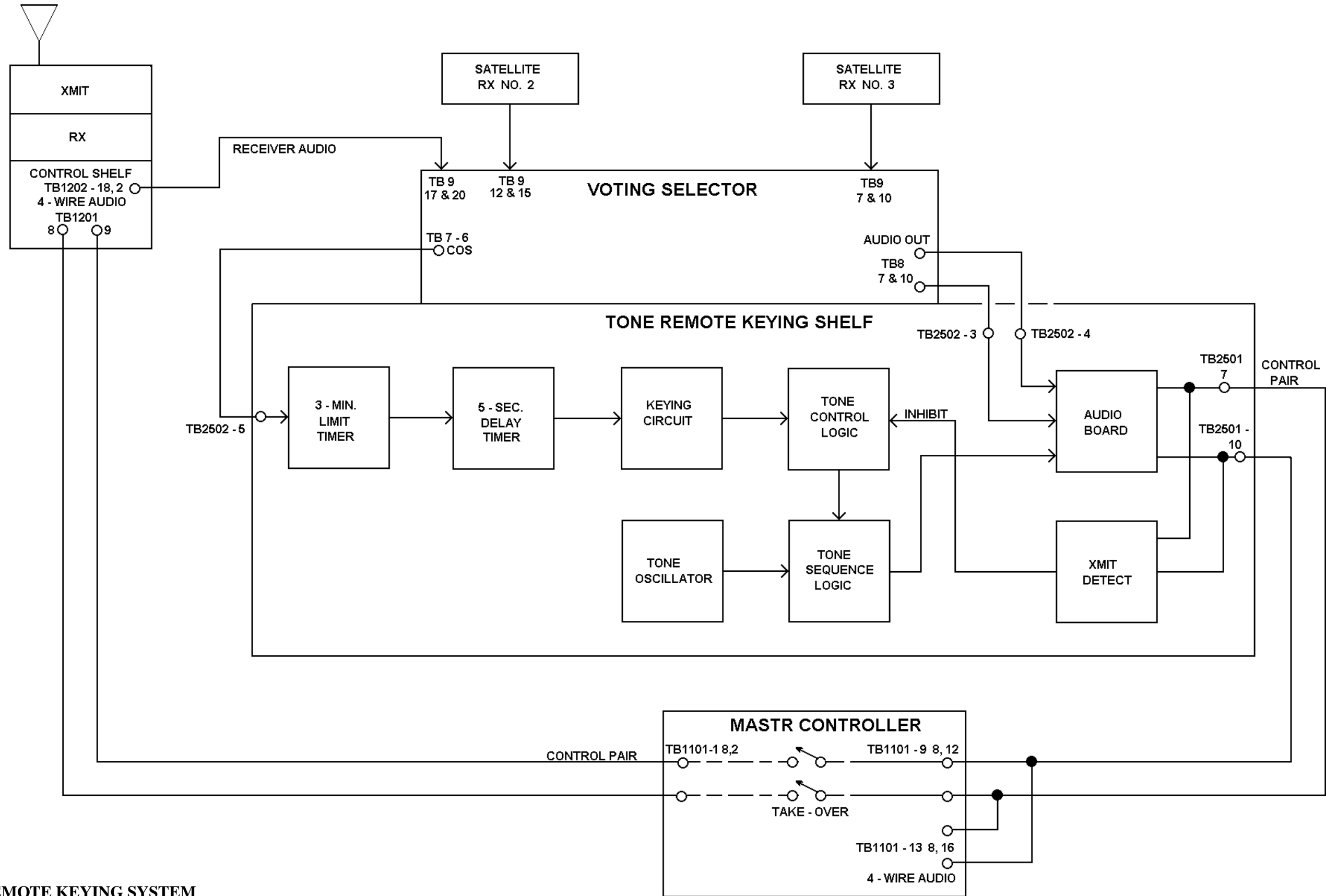

TONE REMOTE KEYING SYSTEM

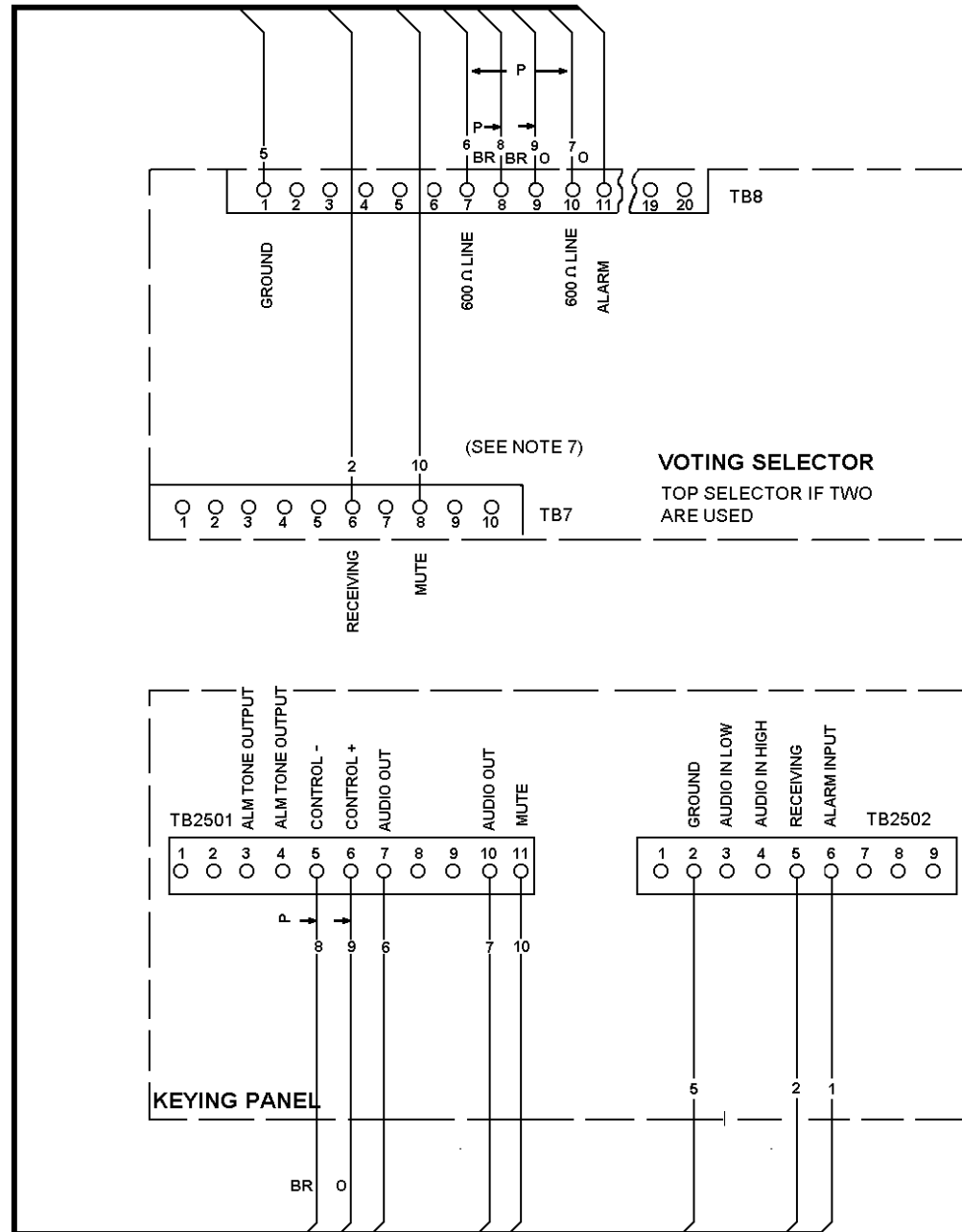

INSTRUCTIONS:

1. TERMINATE ALL WIRES GOING TO TB7 & TB8, VOTING SELECTOR PANEL WITH TERMINAL 19B209260P108.
2. TERMINATE ALL WIRES GOING TO TB2501 & TB2502 KEYING PANEL WITH TERMINAL 19B209260P103.
3. MARK WIRES IN CABLE ON BOTH ENDS WITH CORRESPONDING WIRE NUMBER USING MARKER STRIP 19B209090.
4. EXCEPT AS NOTED, ALL WIRE IS SF-22.
5. N/A
6. CABLE TO BE CONSTRUCTED OF SUCH LENGTH THAT PANELS TOTALING 10.50 INCHES MAY BE PLACED BETWEEN PANELS SHOWN.
7. IN TONE SYSTEMS, WIRE #10 MAY BE REMOVED TO ACCESS VOTED AUDIO AT VOTER OUTPUT.

IN ORDER TO RETAIN RATED EQUIPMENT PERFORMANCE, REPLACEMENT OF ANY SERVICE PART SHOULD BE MADE ONLY WITH A COMPONENT HAVING THE SPECIFICATIONS SHOWN ON THE PARTS LIST FOR THAT PART.

(19C320865, Sh. 1, Rev. 4)

**TONE REMOTE CONTROL HARNESS
19A130010G4**

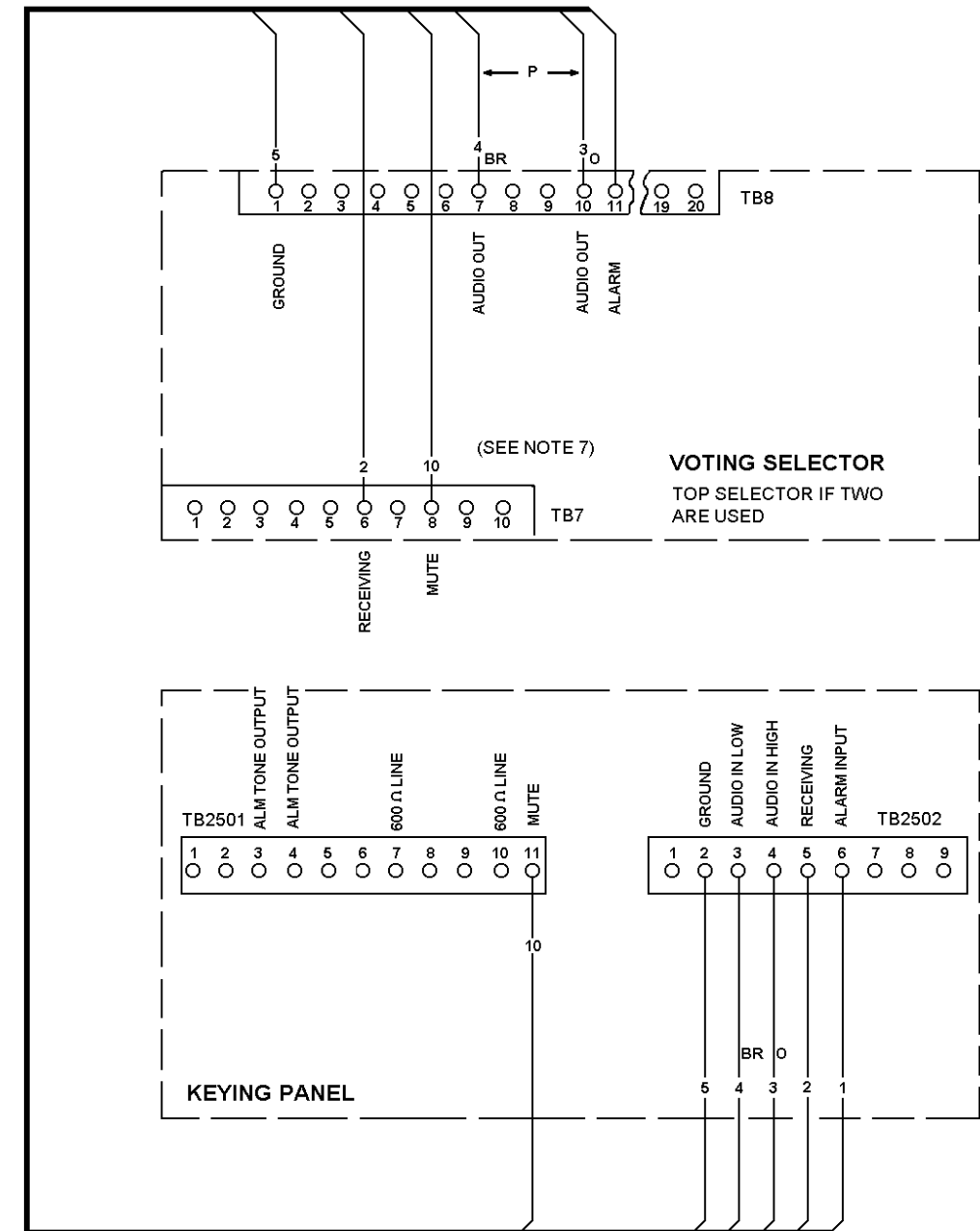

INSTRUCTIONS:

1. TERMINATE ALL WIRES GOING TO TB7 & TB8, VOTING SELECTOR PANEL WITH TERMINAL 19B209260P108.
2. TERMINATE ALL WIRES GOING TO TB2501 & TB2502 KEYING PANEL WITH TERMINAL 19B209260P103.
3. MARK WIRES IN CABLE ON BOTH ENDS WITH CORRESPONDING WIRE NUMBER USING MARKER STRIP 19B209090.
4. EXCEPT AS NOTED, ALL WIRE IS SF-22.
5. N/A
6. CABLE TO BE CONSTRUCTED OF SUCH LENGTH THAT PANELS TOTALING 10.50 INCHES MAY BE PLACED BETWEEN PANELS SHOWN.
7. IN TONE SYSTEMS, WIRE #10 MAY BE REMOVED TO ACCESS VOTED AUDIO AT VOTER OUTPUT.

IN ORDER TO RETAIN RATED EQUIPMENT PERFORMANCE, REPLACEMENT OF ANY SERVICE PART SHOULD BE MADE ONLY WITH A COMPONENT HAVING THE SPECIFICATIONS SHOWN ON THE PARTS LIST FOR THAT PART.

(19C320865, Sh. 2, Rev. 0)

**TONE REMOTE CONTROL HARNESS
19A130010G4**

PARTS LIST

LMI-4632

POWER RECEPTACLE
19B226175G1

SYMBOL	PART NO.	DESCRIPTION
	19A129927G1	Enclosure.
	19B209343P1	Receptacle, power: 15 amps at 125 v; sim to GE 7503-1.
	19B209260P102	Solderless terminal: No. 20-16 wire size; sim to Amp 40763.
	19B226175G2	Harness Assembly.

*COMPONENTS ADDED, DELETED OR CHANGED BY PRODUCTION CHANGES

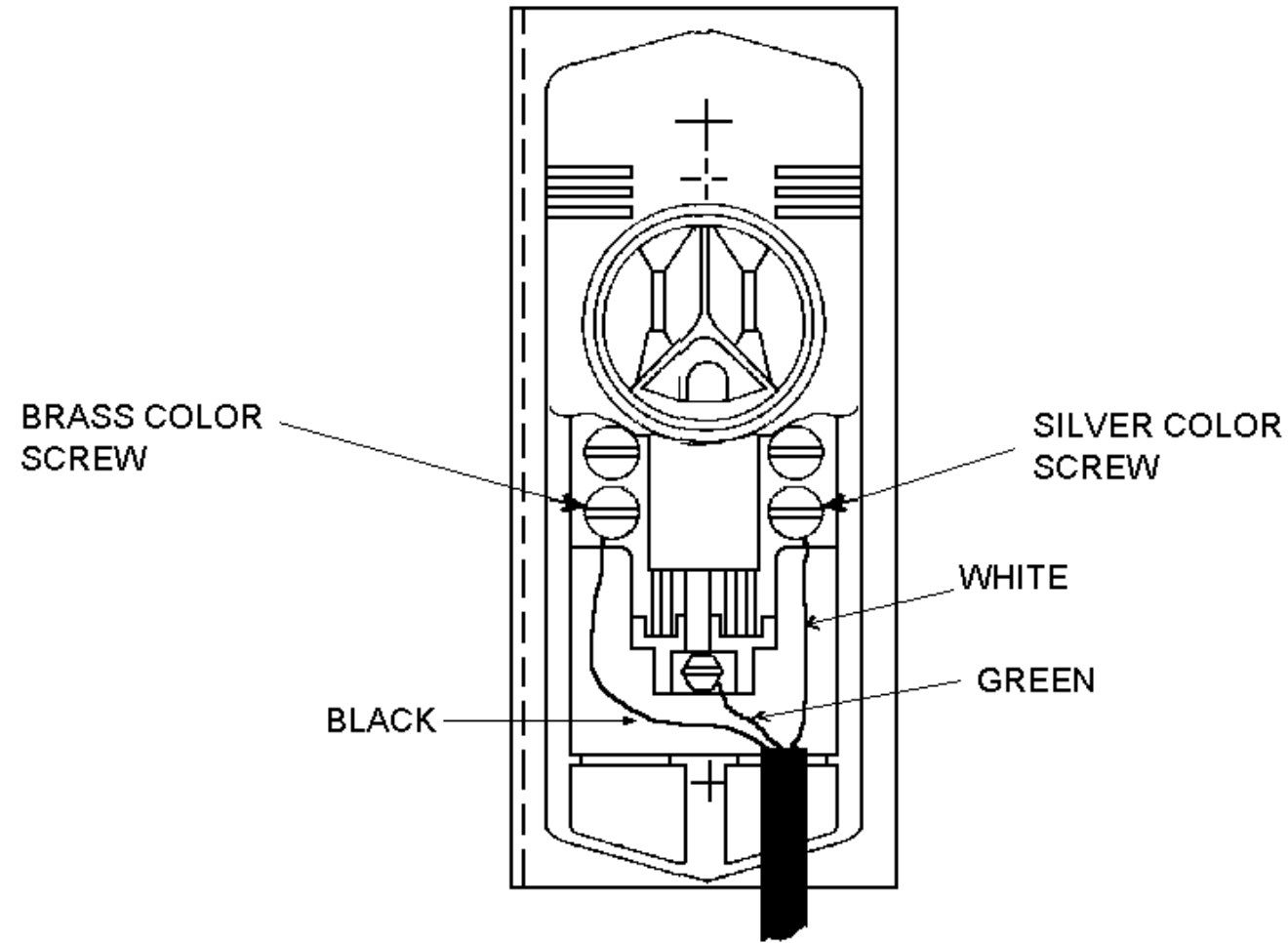

(19B226455, Rev. 0)

RECEPTACLE
19B226175G1

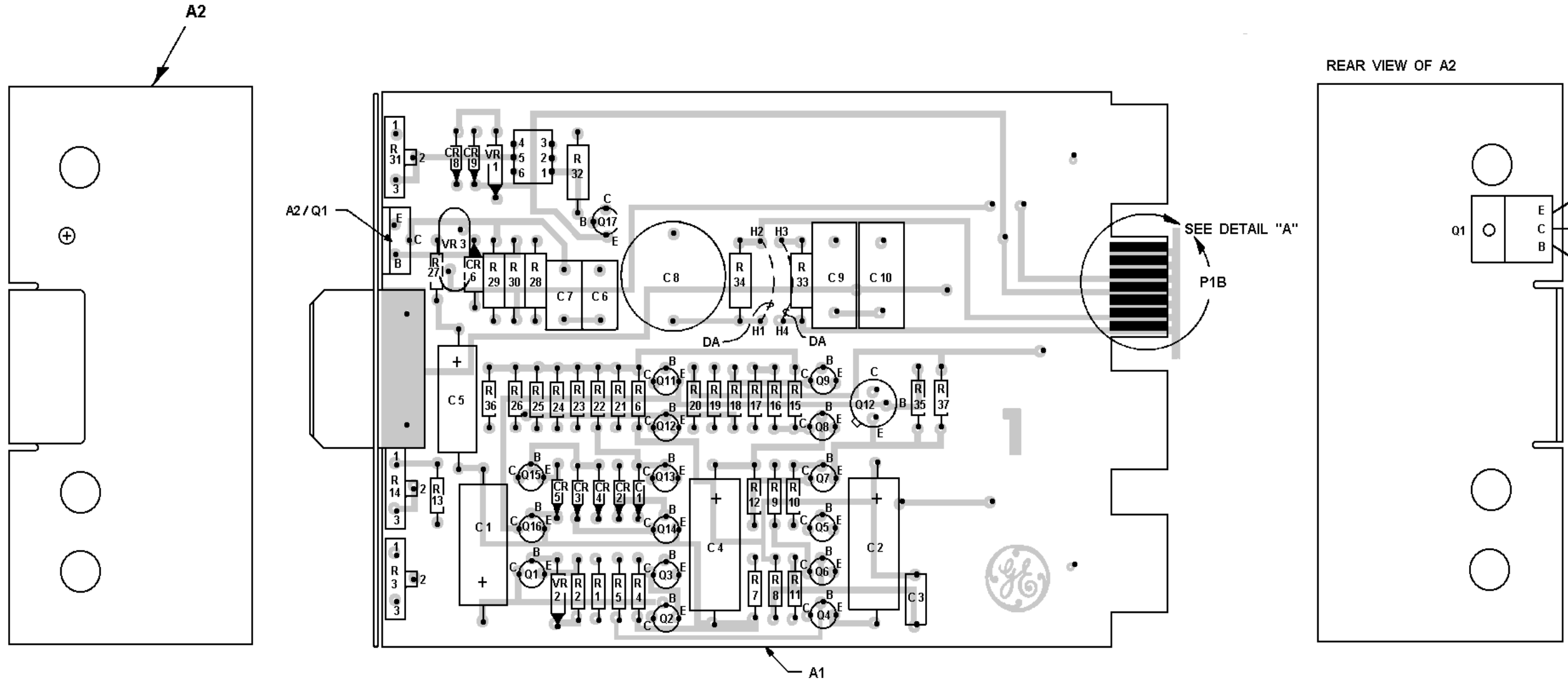

(19D417772, Rev. 1)
(19D417445, Sh. 3, Rev. 1)

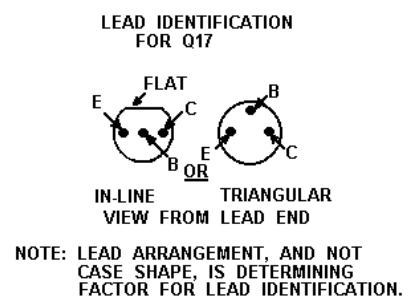
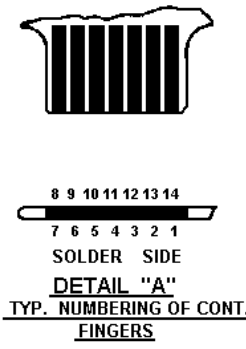
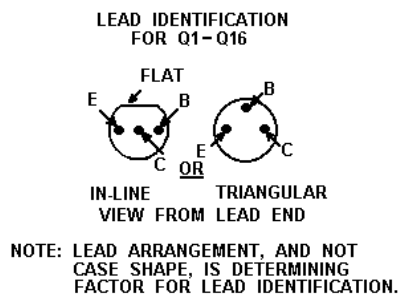

KEYING LOGIC & DC CONTROL BOARD
19D417452G1

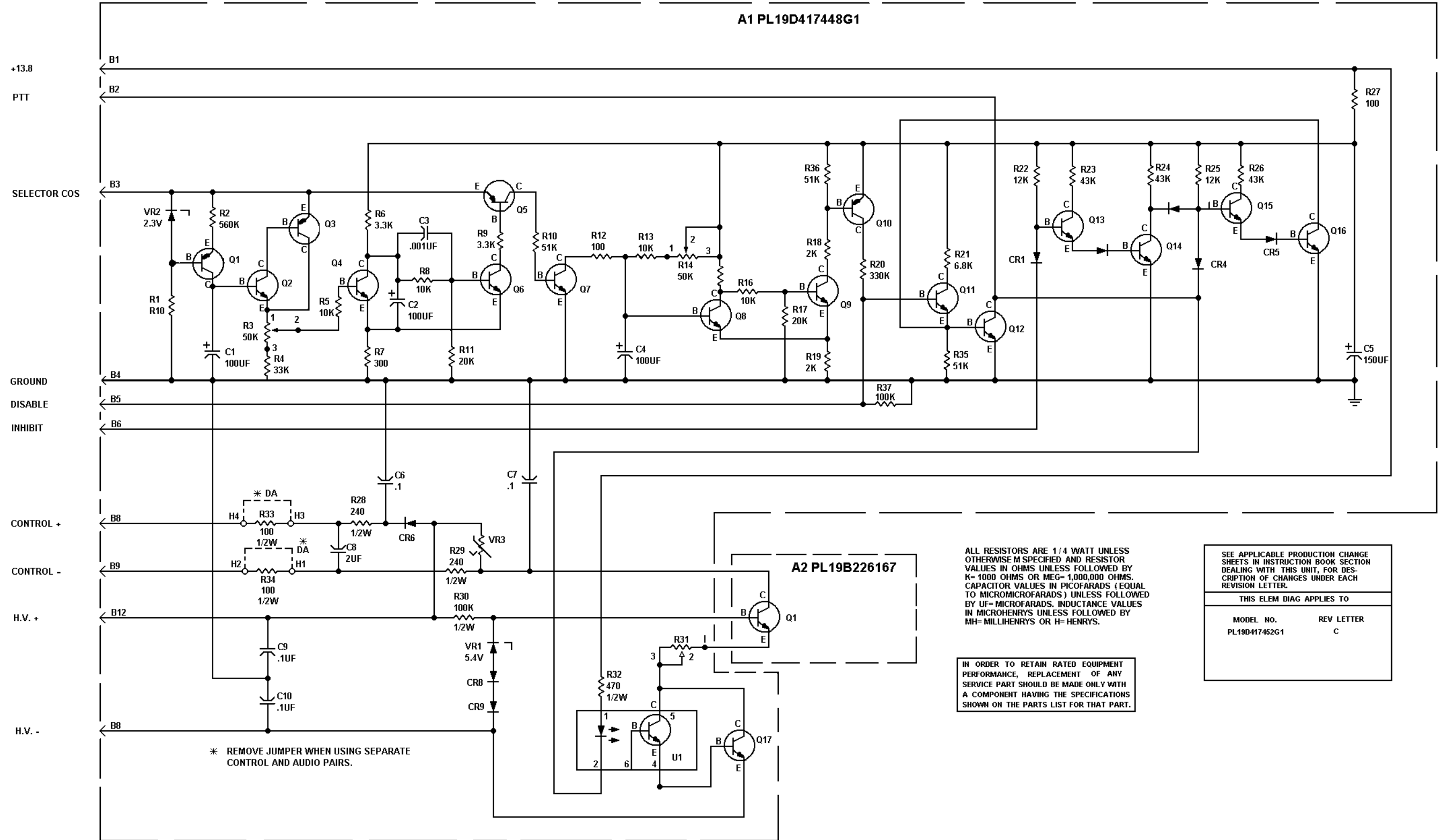

KEYING LOGIC & DC CONTROL BOARD
19D417452G1

(19D417444, Rev. 4)

KEYING LOGIC AND DC CONTROL BOARD
19D417452G1

SYMBOL	PART NUMBER	DESCRIPTION
A1		COMPONENT BOARD 19D417448G1
		----CAPACITORS----
C1* and C2 C3	19A115680P7 77784750P4	Electrolytic: 100 μ F +150-10%, 15 VDCW: sim to Mallory Type TTX. Ceramic disk: 0.001 μ F +100%-0%, 200 VDCW.
C4	19A115680P7	Electrolytic: 100 μ F +150-10%, 15 VDCW: sim to Mallory Type TTX.
C5	5496267P12	Tantalum: 150 μ F \pm 20%, 15 VDCW: sim to Sprague Type 150D.
C6 and C7 C8	19A115080P107 746445P6	Polyester: 0.1 μ F \pm 10%, 50 VDCW/ Electrolytic: Non polarized: 2 μ F-10 +100%, 200 VDCW.
C9 and C10	19A115028P14	Polyester: 0.1 μ F \pm 20%, 200 VDCW.
		DIODES AND ----RECTIFIERS----
CR1 thru CR5 CR6	19A115250:1 19A704142P2	Silicon: Fast recovery, 225mA, 50 PIV. General Purpose Silicon: Sim to 1N4005.
CR8 and CR9	19A115250P1	Silicon: Fast recovery, 225 mA, 50 PIV.
		-----PLUGS----
P1		(Part of printed board 19D417445P1)
		----TRANSISTORS----
Q1	19A115768P1	Silicon: PNP: sim to Type 2N3702.
Q2	19A115910P1	Silicon: NPN: sim to Type 2N3904.
Q3	19A115768P1	Silicon: PNP: sim to Type 2N3702.
Q4	19A115910P1	Silicon: NPN: sim to Type 2N3904.
Q5	19A115768P1	Silicon: PNP: sim to Type 2N3702.
Q6 thru Q9 Q10	19A115910P1 19A115768P1	Silicon: NPN: sim to Type 2N3904. Silicon: PNP: sim to Type 2N3702.
Q11	19A115910P1	Silicon: NPN: sim to Type 2N3904.
Q12	19A115300P4	Silicon: NPN: sim to Type 2N3059.

* COMPONENTS ADDED, DELETED OR CHANGED BY PRODUCTION CHANGES.

SYMBOL	PART NUMBER	DESCRIPTION
Q13 thru Q16 and Q17	19A115910P1	Silicon: NPN: sim to Type 2N3904.
		----RESISTORS----
R1	3R152P511J	Composition: 510 Ohms \pm 5%, 1/4 Watt.
R2	3R152P564J	Composition: 560k ohms \pm 5%, 1/4 Watt.
R3	19B209358P108	Variable, carbon film: Approximately 2k Ohms to 50k Ohms \pm 10%, 1/4 Watt; sim to CTS Type X-201.
R4	19A700106P99	Composition: 33k Ohms \pm 5%, 1/4 Watt.
R5	19A700106P87	Composition: 10k Ohms \pm 5%, 1/4 Watt.
R6	19A700106P75	Composition: 3.3k Ohms \pm 5%, 1/4 Watt.
R7	3R152P301J	Composition: 300 Ohms \pm 5%, 1/4 Watt.
R8	19A700106P87	Composition: 10k Ohms \pm 5%, 1/4 Watt.
R9	19A700106P75	Composition: 3.3k Ohms \pm 5%, 1/4 Watt.
R10	ER152P513J	Composition: 51k Ohms \pm 5%, 1/4 Watt.
R11	3R152P203J	Composition: 20k Ohms \pm 5%, 1/4 Watt.
R12	19A700106P39	Composition: 100 Ohms \pm 5%, 1/4 Watt.
R13*	19A700106P87	Composition: 10k Ohms \pm 5%, 1/4 Watt.
R14	19B209358P108	Variable, carbon film: Approximately 2k Ohms to 50k Ohms \pm 10%, 1/4 Watt; sim to CTS Type X-201.
R15	3R152P202J	Composition: 2k Ohms \pm 5%, 1/4 Watt.
R16	19A700106P87	Composition: 10k Ohms \pm 5%, 1/4 Watt.
R17	3R152P203J	Composition: 20k Ohms \pm 5%, 1/4 Watt.
R18 and R19 R20	3R152P202J 3R152P334J	Composition: 2k Ohms \pm 5%, 1/4 Watt. Composition: 0.33 Megohms \pm 5%, 1/4 Watt.
R21	19A700106P83	Composition: 6.8k Ohms \pm 5%, 1/4 Watt.
R22	19A700106P89	Composition 12k Ohms \pm 5%, 1/4 Watt.
R23 and R24 R25	3E152P433J 19A700106P89	Composition: 43k Ohms \pm 5%, 1/4 Watt. Composition: 12k Ohms \pm 5%, 1/4 Watt.
R26	3R152P433J	Composition: 43k Ohms \pm 5%, 1/4 Watt.
R27	19A700106P39	Composition: 100 Ohms \pm 5%, 1/4 Watt.
R28 and R29	3R77P241J	Composition: 240 Ohms \pm 5%, 1/2 Watt.

SYMBOL	PART NUMBER	DESCRIPTION
R30	19A700113P111	Composition: 100k Ohms \pm 5%, 1/2 Watt.
R31	19B209358P104	Variable, carbon film: Approximately 50 Ohms to 250 Ohms \pm 10%, 1/4 Watt; sim. to CTS Type X-201.
R32	19A700113P55	Composition: 470 Ohms \pm 5%, 1/2 Watt
R33 and R34 R35 and R36 R37	19A700113P39 3R152P513J 19A700106P111	Composition: 100 Ohms \pm 5%, 1/2 Watt. Composition: 51k Ohms \pm 5%, 1/4 Watt. Composition: 100k Ohms \pm 5%, 1/4 Watt.
U1	19A115908P1	-INTEGRATED CIRCUITS- Coupler, opto- electronic: 6 pin, dual inline: sim to Fairchild FCD5004.
		VOLTAGE ---- REGULATORS----
VR1	4036887P5	Zener: 500 mW, 5.4V (nominal).
VR2	4036887P1	Zener: 500 mW, 2.3V (nominal).
VR3	19A134142P1	Electrical surge arrestor, (Varistor): sim to CE SPD #V130LAX57B
A2		TRANSISTOR SUPPORT 19B226167G1
		----TRANSISTORS----
Q1	19A129183P1	Silicon: NPN.
		----MISCELLANEOUS----
	19A116022P1	Insulator, bushing (Used with Q1 on A2).
	19A116023P1	Insulator, plate (Used with Q1 on A2).
	4036555P1	Insulator, washer: Nylon (Used with Q12 on A1).
	19B219690G1	Handle Assembly.