

HAMTRONICS® CC432 UHF RECEIVING CONVERTER

ASSEMBLY, INSTALLATION, OPERATION, AND MAINTENANCE

FUNCTIONAL DESCRIPTION.

The CC432 is a low-noise receiving converter designed, in several models with variations in tuned circuits, to convert signals in the uhf range to an i-f frequency in the hf or vhf range. Following is a list of common CC432 Converter models.

Model #	Input Range	Output Range
CC432-2	432-434	28-30
CC432-5	435-437	28-30
CC432-3	435.5-437.5	28-30
CC432-4	432-436	144-148
CC432-9	439.25 ATV	61.25 (Ch 3)

The converter is available in three configurations: pc board kit with case and BNC jacks, pc board kit less case (RCA jacks on board), and wired and tested unit in case with BNC jacks.

THEORY OF OPERATION.

The circuit for the converter is relatively simple. A GaAsFET rf amplifier is coupled to a mos fet mixer through a triple-tuned circuit for selectivity. An overcoupled double-tuned mixer output tank circuit is used to achieve a wide bandwidth.

Oscillator Q3 uses fundamental crystals in the 14-16 MHz range for easy frequency trimming. The collector circuit is tuned to the third harmonic of the crystal frequency, about 42-48 MHz. Q4 triples this frequency again to about 126-144 MHz. Then, Q5 either triples this again to the 378-407 MHz range, or in the case of the two-meter output model, it doubles to about 288 MHz. Double-tuned circuits are used throughout the multiplier/injection chain for signal purity.

Following is a summary of the frequency scheme for each model.

Model	Injection	Xtal Freq.
CC432-2	404	14.962962
CC432-5	407	15.074074
CC432-3	407.5	15.092592
CC432-9	378	14.000000
CC432-4	288	16.000000

CONSTRUCTION.

Note that uhf equipment requires precise construction using short, direct leads. Seat parts as close to the board as possible without overstressing the leads.

Be sure to follow instructions as given and don't arbitrarily do things differently. Refer to the component location diagram and parts list during

assembly.

CAUTION: The chip capacitors are very small and easy to damage, mix up, or lose. Leave them in the plastic carrier strips until time to install.

CAUTION: Static handling precautions are required for the fet's. The small geometry and high impedances make FET's heat and static sensitive; so be careful. It is good to discharge your hand to a grounded metal object just before picking up a transistor, and the use of a grounded soldering iron is mandatory. A heat sink is not necessary while soldering if you are careful to apply no more heat than necessary.

Do not be overly anxious about blowing out the fet's if you observe these precautions. The transistors are all factory tested and wrapped in foil to ensure that they arrive in good condition. There is no warranty coverage for damage which occurs in construction or handling; but replacement transistors are moderately priced.

a. Set board on bench or in holding jig oriented as shown.

b. Begin by tack soldering the two FET's (Q1 & Q2) to the foil on the top of the pc board. Orient the drain (long) leads as shown. *Lettering on the transistors should be up.* (See detail at the left side of the diagram.) Carefully bend the leads at right angles toward the bottom of the FET's, and install them in the four holes for each transistor. Solder the pads under the board.

c. Install the six small variable ceramic capacitors and the one piston variable capacitor, orienting them as shown. See parts list for values.

d. Install chip capacitors and resistors on top of board as follows. Use small tweezers to handle them. Be careful not to drop them, because they are difficult to find. Since they have no markings, be sure to leave them in the package until installed so you can tell the values apart. Refer to parts list for values. (An additional chip resistor will be installed on the bottom of the board later.)

Note where capacitors and resistors are to be positioned. They must straddle the area between a pad on the board and the ground plane, with

one electrode soldered to each. Do all of one value at a time; then start the next value of capacitor, and so on until done.

Apply a little solder to the pads where one end of each capacitor will be positioned. Do not apply solder to the ground plane yet, just the pads isolated from the ground plane. (You can pretin the isolated pads for all of the chip capacitors and resistors now, but install only one value at a time.)

Pick up one part at a time, removing it carefully from its carrier strip by peeling back the tape with a knife or diagonal cutters. Set the part in place. Then heat the solder on the pc board pad, and allow the solder to bond to the electrode on the part. When the solder melts, the part will seat down on the board in the molten solder. (It is essential that this process be done relatively quickly so the solder doesn't oxidize and so there is still a little flux left where the capacitor electrode sits.)

After one end of each of the parts is soldered and the positions have been confirmed to be correct, solder the other end of each part to the ground plane. Repeat for other values of chip capacitors and resistors.

e. In like manner, solder chip resistor R2 on the bottom of the board as indicated in the detail view to the right of the diagram.

f. If RCA jacks are to be used (no case), install them on the board. Orient them with the center conductor tab toward the circuitry on the board, rather than toward the edge of the board. Solder ground tabs to ground plane on top of board, and solder center contacts under board. If the pc board will be installed in a case, the RCA jacks will not be used; in this case, tack solder a 1" length of #20 bus wire to the pad for the center conductor of each of the jack positions, bringing the free end of the wire out the top of the hole to be connected later to the BNC jack, as shown in the diagram.

g. Tack solder the shield in place between Q1 and L2 as shown. The front of the shield should be flush with the front edge of the board. Cut top corners of the shield on a 45° angle just a little to remove sharp edges.

h. Install all disc and monolithic

ceramic capacitors with very short leads. Install electrolytic capacitor C16, observing polarity.

i. Install all resistors. They are mounted vertically; be sure to orient the body of the resistor as shown by large circles in parts location diagram. Leave the top leads of R12 and R14 about 1/8" high to act as test points. (See detail.)

j. Install transistors Q3-Q5 and voltage regulator ic U1, orienting as shown and using short leads.

k. Install ferrite beads Z1-Z5, and solder leads to board. The beads are already strung on bus wire.

l. Wind coils L2-L4 and L11-L12 with #20 bus wire on 1/8 inch diameter drill bit shank, and then install them on the board. Be sure to wind them in the direction shown so coils are oriented as indicated. Leave the bottom of each coil 1/16 inch above the ground plane. After soldering, space the turns neatly to fill space between pads on the board. L4, especially, must be spaced out considerably between turns, as shown in diagram.

m. Form coil L1, which is a 3/4 turn loop formed from #20 bus wire. Measure before soldering; the top of the coil wire should be exactly 3/16 inch above the top of the pc board.

n. Install jumper JMP-1 at Q1 as shown. Use #20 bus wire, and tack solder from the pad at the source lead of Q1 to the adjacent ground plane, keeping the jumper as short as possible.

o. Install slug tuned coils as shown, and install coil shields. The 2-1/2 turn (red) coils come with shields already on the coils; however, in some cases, the shield must be removed and rotated 90° in order to fit holes in pc board. The 6-1/2 turn (blue) coils and other coils have shields supplied separately.

The shorter coils used for L5 and L6 require slugs to be installed. Be sure that you have a properly fitting tuning tool, e.g. our model A28 Tuning Tool; if the tool slips in the slot, it will fracture the tuning slug. Note that the shields for L5 and L6 will have their bottoms up off the board slightly; this is normal due to the height of the coil form.

Make sure the coils and shields are fully seated, and solder both shield lugs. (Do not bend lugs over, but you can bend the coil leads over a little to hold them in place while soldering.)

p. Install crystal Y1. Insert leads through board and solder, using care not to apply excessive heat. Normal soldering heat is OK, but avoid "cooking" the crystal by heating pads for excessive periods of time. Allow a tiny bit of space between the crystal and the pc board to avoid having the metal base short to the pads for the leads.

q. Check over all parts and solder connections. If any parts are missing, see if you have other parts left over. You may have installed a wrong value somewhere; so recheck all values looking for the missing parts. Color codes and printed numbers are difficult to read on many small parts, so care is sometimes needed to avoid mixups.

CASE ASSEMBLY.

If the converter was purchased with case, perform these additional steps.

a. Set lower half of case on bench, oriented as shown.

b. Fasten one angle nut to hole half way back on each side, between the two pc board mtg holes shown in diagram. (See detail.) Insert 4-40 x 1/4" screw from bottom of case; then install angle nut from top of case. The leg with the longer dimension from the bend to the hole goes over the screw, leaving the side with the shorter dimension for the cover screws to engage. Before tightening the screws, carefully align the angle nuts flush with the edge of the chassis.

c. Install pc board in case oriented as shown, using eight 4-40 x 1/4" screws and four threaded standoffs. Attach standoffs to case first, and then fasten board to standoffs.

d. Install the two BNC jacks as shown. Put connector through hole; and secure with lockwasher, ground lug, and nut. Orient ground lugs as shown, and bend them at right angles as close to nut as possible for direct ground path.

e. Install feedthrough terminal from front of case, and secure with mating nut.

f. Solder a short length of bus wire from the feedthru to B+ terminal pad E1 on the pc board.

g. Solder short pieces of #20 bus wire (left over from L1 & L2) between the BNC ground lugs and the pc board ground plane directly adjacent to lugs (shortest possible path).

h. When the pc board was assembled, bus wire leads were attached to the pc pads normally used for the

RCA jacks on the board. Tack solder these leads to respective BNC jack center conductors, using most direct route.

i. Remove backing paper from the rubber feet, and stick one in each corner on the bottom of the case, about 1/2 inch in from each edge of the case.

j. This completes assembly. After alignment, slide top cover over case, and secure with one 4-40 screw in each side of the cover.

CRYSTALS.

Crystals are standard HC-25/u, fundamental, 32pf, parallel resonant units with .001% grinding tolerance. The crystal frequency normally falls in the 14-16 MHz range. The parts list gives frequencies of crystals for common models. In general, the following formulas apply.

For most models, those with an i-f output in the 28-62 MHz range, the multiplier is 27; so,

$$\text{crystal freq} = (\text{input} - \text{output})/27.$$

For the CC432-4 model, with an i-f output in the 144-148 MHz range, the multiplier is 18 instead of 27; so,

$$\text{crystal freq} = (\text{input} - \text{output})/18.$$

We stock common crystals and will gladly order special ones for you. If you order directly from a crystal lab, make sure you order commercial-grade crystals, and be sure to give them complete specs.

Crystals may be supplied in either HC-49/u holder (solid pins) or HC-50/u (wire leads). Either type is soldered to the board, using care not to apply excessive heat. Normal soldering heat is OK, but avoid "cooking" the crystal by heating pads for excessive periods of time. Allow a tiny bit of space between the crystal and the pc board to avoid having the metal base short to the pads for the leads.

ALIGNMENT.

Equipment needed for alignment is a 12 to 14 Vdc regulated power supply, a sensitive dc voltmeter, and a stable signal generator or strong on-the-air signal. If you use a tunable signal generator, warm it up long enough to assure stability.

The tuning slugs in the coils require a .060 inch square tuning tool. We offer the A28 tool in our catalog. Be careful not to attempt tuning with a makeshift tool, which would likely crack the slugs and make them seize up.

a. Preset all variable capacitors

and tuning slugs to midrange. Capacitors are at maximum capacitance from the factory; so turn each rotor 90°. Note that it is ok for tuning slugs to extend partially above the top of coils.

b. Connect dc voltmeter, set to low dc range, to TP1 (hot lead of R12). Adjust L7 and L8 alternately for maximum on the meter. (It may be necessary to try different combinations of the two coils to get initial indication.) Expected voltage is roughly in the 1 to 2.5Vdc range; the exact voltage is unimportant.

c. Connect meter to TP2 (hot lead of R14). Adjust L9 and L10 alternately for maximum response. Remove meter. Expected voltage is roughly in the 0.4 to 1Vdc range; the exact voltage is unimportant.

d. Apply strong input signal at the center of the band to be used, and monitor S-meter on receiver.

e. Alternately peak the following variable capacitors for maximum signal strength: C34/C35 in the last multiplier stage, C5/C7/C8 at the mixer input, and C2 at the rf amplifier input. Go through a few times and work out any interactions between adjustments. Note that C2 tuning will be relatively broad.

f. Peak L5 and L6 for maximum signal strength.

g. To adjust the oscillator frequency precisely, put in a signal on the exact frequency desired and adjust piston trimmer capacitor C18 for

"on-frequency" response by what ever means you can measure frequency error. If you don't have a way of judging frequency error on your receiver (bfo, etc.), you can check the oscillator frequency with a frequency counter at TP1. (If your crystal is just a little too far out to net this way, you can try changing C19 a little to compensate.)

INSTALLATION.

Installation depends on the type of converter ordered. Connect J1 to the uhf antenna and J2 to the input of the receiver used for listening. RCA plugs are used for boards without a case. BNC plugs are used for units supplied with a case. Always use best quality low-loss coax at uhf frequencies.

The power terminal on the pc board or the feedthrough terminal on the front of the case should be soldered to a source of +12 to +14 Vdc, preferably a regulated power supply.

Be sure that the same power supply is not connected to any devices which could produce damaging voltage transients, for example, motors or relay coils. Reverse diodes should be used across such devices to limit transient pulses. The converter draws about 25 mA.

TROUBLESHOOTING.

The usual techniques of checking dc voltages at transistor terminals and tracing oscillator injection signals with

an rf probe and vtm are appropriate for this converter.

A dc voltage chart is given to indicate typical voltages. The measured voltages may vary from unit to unit and with different meter types because of loading and the presence of rf; so use the information only as a general guide.

Current drain of the converter, typically about 25 mA, is also a good indication of any problems on the B+ line.

Gain of the converter is about 18-20 dB. Sensitivity when connected to a typical 10 meter receiver is about 0.2 uV for 12 dB sinad.

When troubleshooting a unit which has just been built, be sure to check for solder splashes, bad solder joints, parts mixed up, etc. It is easy to have something like that happen during construction.

Following are approximate positive dc voltages with respect to ground measured with an fet vm on a sample unit operating on 13.6 Vdc.

XSTR	Emitter	Base	Collector
Q3*	4.0	4.3	8.0
Q3**	3.3	4.0	8.0
Q4	2.0	0	8.0
Q5	0.6	0	8.0

* Crystal present.

** Crystal pulled out or oscillator signal otherwise absent

XSTR Source	G1	G2	Drain
Q1	0	0	4 8.0
Q2	0.5 to 1	0	4 8.0

PARTS LIST.

Note: ♦ means see end of list for different values for models other than 28-30 MHz i-f.

Ref Desig	Description (marking)
C1	6 pf disc
C2	4.5 pf var cap (white)
C3	not assigned
C4	.01 uf 1206 chip
C5	4.5 pf var cap (white)
C6	100 pf 805 chip
C7-C8	4.5 pf var cap (white)
C9-C11	.01 uf 1206 chip
C12 ♦	150 pf disc
C13 ♦	10 pf disc
C14 ♦	150 pf disc
C15 ♦	680 pf disc (681)
C16	0.47 uf electrolytic
C17	.01 uf 1206 chip
C18	11 pf piston trimmer
C19	43 pf disc
C20-C21	150 pf disc (151)
C22	.01 uf disc (103)
C23	68 pf disc
C24	1 pf disc
C25	68 pf disc
C26-C27	.001 uf disc (102)
C28 ♦	18 pf disc
C29	0.5 pf disc
C30 ♦	39 pf disc
C31 ♦	47 pf disc
C32	100 pf 805 chip
C33	30 pf disc
C34-C35	4.5 pf var cap (white)
J1-J2	RCA or BNC jack
JMP-1	Jumper (#20 bus wire)
L1	¾ turn loop #20 bus wire on 1/8" i.d., 3/16" high (see text for details on all air-wound coils)
L2	2¾T #20 bus wire on 1/8" i.d.
L3	3¾T #20 bus wire on 1/8" i.d.
L4	1¾T #20 bus wire on 1/8" i.d.
L5-L6 ♦	7½T slug-tuned coil, loose-wound (violet)
L7-L8	6½T slug-tuned coil, space-wound (blue)
L9-L10	2½T slug-tuned coil, space-wound (red)
L11 ♦	2¾T #20 bus wire on 1/8" i.d.
L12 ♦	3¾T #20 bus wire on 1/8" i.d.
Q1-Q2	N.E.C. 3SK122 mos fet (static sensitive!)
Q3-Q4	2N5770
Q5	PN5179
R1	not assigned

R2-R3	68K chip
R4	not assigned
R5-R6	100K
R7	200Ω chip
R8	1.2K carbon film
R9-R10	15K carbon film
R11	2.2K carbon film
R12	680Ω carbon film
R13	3.3K carbon film
R14	1.2K carbon film
U1	78L08 voltage regulator

Y1		Crystal, see text:	
Model	Xtal Freq.		
CC432-2	14.962962		
CC432-5	15.074074		
CC432-3	15.092592		
CC432-9	14.000000		
CC432-4	16.000000		

Z1-Z5	Ferrite beads
-------	---------------

♦ Note: Following are different values used for CC432-9 (439.25-61.25 MHz):

C12	30 pf disc
C13	0.5 pf disc
C14	43 pf disc
C15	150 pf disc

♦ Note: Following are different values used for CC432-4 (432-144 MHz):

C12	15 pf disc
C13	0.5 pf disc
C14	20 pf disc
C15	62 pf disc
C28	15 pf disc
C30	33 pf disc
C31	39 pf disc
L5-L6	2-1/2 turns space-wound (red)
L11	4-3/4 turns on 1/8" i.d.
L12	5-3/4 turns on 1/8" i.d.

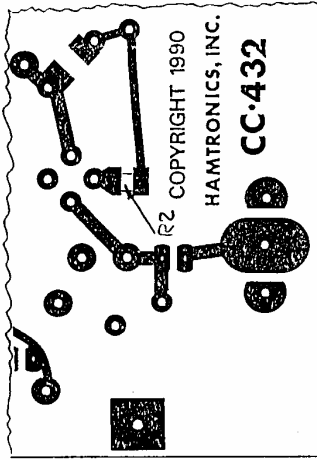

VIEW OF RESISTOR MOUNT BOARD

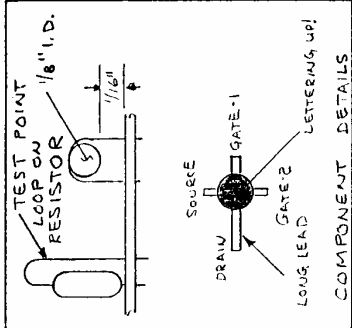
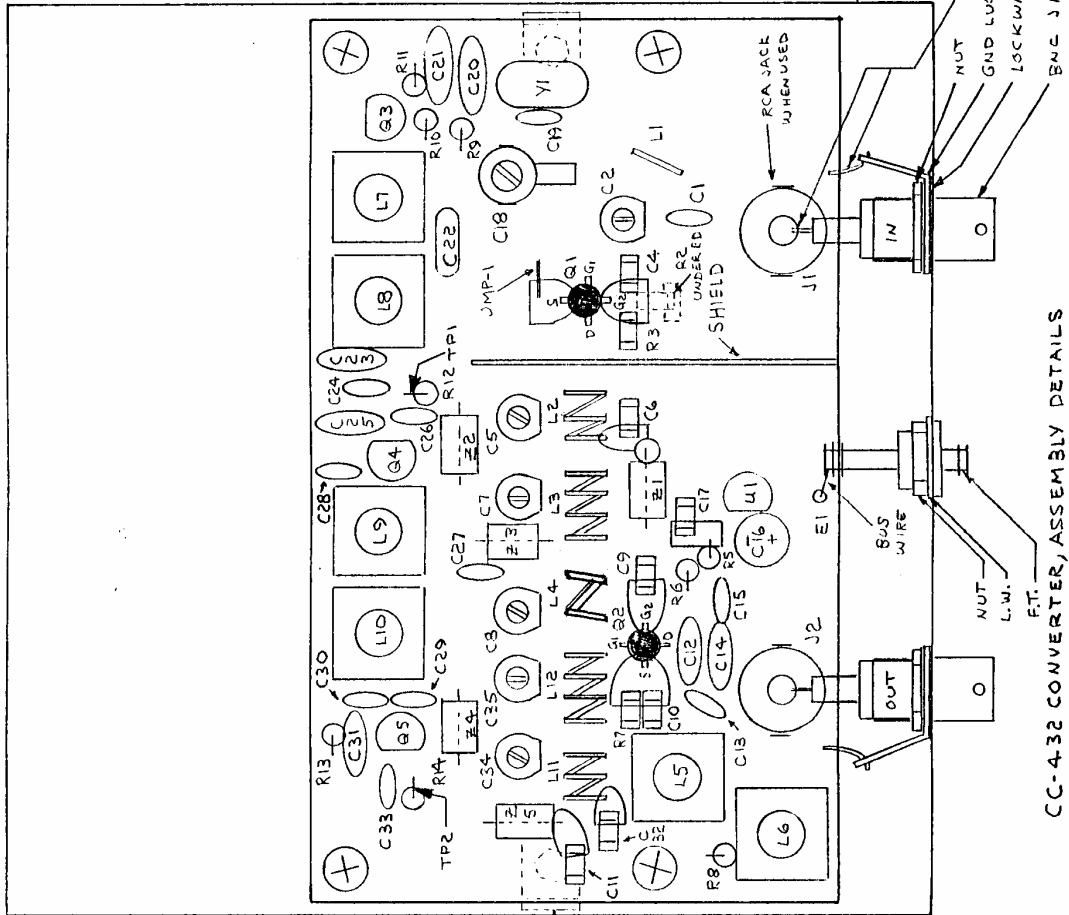

SEE ANGLE NUT DETAIL BELOW

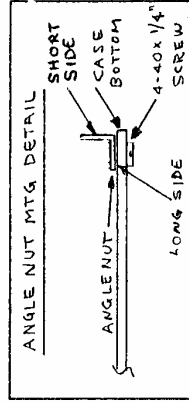

CC-432 CONVERTER, ASSEMBLY DETAILS

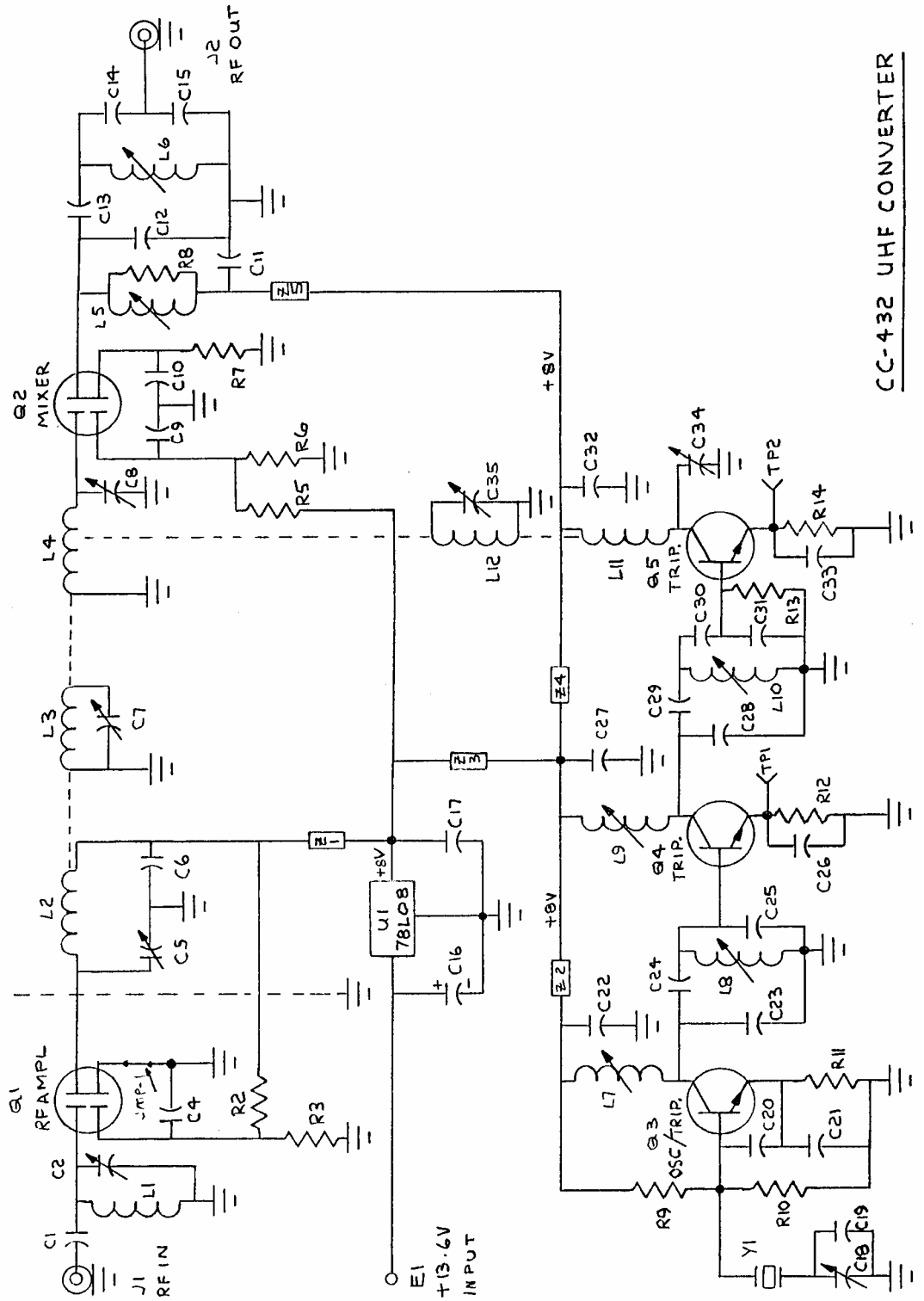

CC-432 UHF CONVERTER

CHIP PARTS FOR CONSTRUCTION OF CC432 UHF CONVERTER:

2 ea 100 pf 805 chip caps:

5 ea .01 uf 1206 chip caps:

1 ea 200 Ω 1206 chip res:

2 ea 68k 805 chip res: