

Note that vhf equipment requires precise construction using short, direct leads. Be sure to follow instructions as given and don't arbitrarily do things differently. For example, some people add ic sockets to modules they build, but this kit is designed without them for proper heatsinking and rf performance.

When installing resistors that are mounted vertically, be sure to orient the body of the resistor as shown by large circles in parts location diagram. Note that parts shown in phantom are installed on bottom of board.

a. Set board on bench or in holding jig oriented as shown.

b. Install phono jack J1. Solder all four tabs under board.

c. Install feedthrough capacitors C3, C4, C7, and C8 from bottom of board. Solder outside metalization to ground plane on board, flowing solder neatly all around perimeter of capacitor.

d. Install GaAs FET's Q1 and Q2 from top of board, ORIENTING AS SHOWN, and seat them as close to board as possible without straining leads. Note that the **LETTERING SHOULD BE UP**. Solder leads under board. Solder the gate-1 lead first; since it may be necessary to reposition the fet slightly to make the lead reach through the board. Then, solder the drain lead.

The source and gate-2 leads should then be soldered to the inside metalization of the feedthrough capacitors. This is done by applying the iron and solder to the wire lead and allowing solder to flow into capacitor. Static handling precautions are required for the fet's.

CAUTION: The small geometry and high impedances make GaAs FET's heat and static sensitive; so be careful. It is good to discharge your hand to a grounded metal object just before picking up the transistor, and the use of grounded soldering irons is mandatory. A heat sink is not necessary while soldering, but be careful not to apply any more heat than necessary.

You should not be overly anxious about blowing out the fet's if you observe the precautions above. The transistors are all factory tested and wrapped in foil to ensure that they arrive in good condition. There is no warranty coverage for damage which occurs in construction or handling; but replacement transistors are moderately priced.

e. Turn the board upside down to install parts shown in phantom.

Solder R2 in place with one lead inserted from bottom of board through hole in circuit trace and the other lead tack soldered to the center of FT cap C3.

f. Solder R1 in place with one lead tack soldered to the center of C3 and the other lead soldered to the hole provided in the ground plane in the position shown. Solder R3 from the center of C4 to the hole in the ground plane in position shown.

g. Solder R5 from the center of C7 to the ground plane hole in the center of where T3 goes. Solder R6 from the center of C7 to the circuit pad next to where R8 goes.

h. Solder R7 from the center of C8 lead to ground plane in position shown. There is no hole for R7's ground lead; merely tack solder to ground plane under L7 as indicated. Trim off leads protruding through top of board before proceeding.

i. Locate the two toroid cores and fine magnet wire. In winding toroids T1 and T3, try to spread the turns out to cover as large an area of the toroid as possible for good coupling. Refer to parts list for correct number of primary and secondary turns.

Note: The primary is defined as the larger number of turns, and the secondary is the smaller number of turns.

Wind primary first and trim leads to a fixed length so you can identify them. Then wind secondary over primary in the proper position as indicated in the diagram. Leave secondary leads long so you can tell them from primary leads. Lastly, insert leads in primary (P) holes and secondary (S) holes as marked in diagram, pull leads tight, and solder.

The wire has special solderable insulation; so merely cut lead to 1/8" length after pulling tight and bending over, and then solder with a hot iron. The insulation will melt away after a few seconds.

j. Install helical resonator T2, aligning pins and tabs to match holes in board. Be sure to solder tabs as well as pins.

k. Install crystal filters FL1-FL4. Start with either filter having only one color dot. Install in position FL1 with color dot down toward front of board as shown. Install filter with matching color dot in position FL2 so that matching color dots on FL1 and FL2 are adjacent to each other.

The idea is to connect these tandem filters in the circuit in the same sequence as they were matched at the factory.

Likewise, install FL3 with color dot to match adjacent dot on FL2. Then, install FL4 with only one remaining color dot adjacent to matching color dot on FL3.

To recap, the filters are installed with uncoded ends to the outside world, and the terminals which are connected to each other all have matching color dots.

l. Install ferrite beads Z1-Z3, and solder leads to board.

m. Install U1, U2, CR1, CR2, and VR1, observing polarity. IC's have a dot over pin 1 for identification as shown in diagram.

n. Install electrolytic capacitors, observing polarity.

o. Install slug tuned coils as shown, and install coil shields. The 2-1/2 turn (red) coils come with shields already on the coils; however, in some cases, the shield must be removed and rotated 90° in order to fit holes in pc board. The 6-1/2 turn (blue) coils have shields supplied separately.

Make sure the coils and shields are fully seated, and solder both shield lugs. (Do not bend lugs over, but you can bend the coil leads over a little to hold them in place while soldering.)

p. Install pots R20 and R22. They should be held in position while soldering so shafts are at right angles to board, thereby minimizing strain on leads when pots are later secured to front panel.

q. Install socket pins at E1-E4, TP3, and Y1. (If crystal oven is used, omit sockets at Y1, but install one at E4 for the oven power connection.) Cut socket pins from carrier strip close to body. Rock them while firmly pressing into board. They will snap in place. Solder lightly under board (to avoid solder filling crystal sockets).

r. Install all remaining components as per location diagram and parts list. Leave the top lead of R18 about 1/8" high to act as a test point. Also form a little test point loop in the rear lead of R21.

s. Install bus wire jumpers as shown.

t. Check over all parts and solder connections. If you are missing any parts, check to see if you have other parts left over. You may have installed a wrong value somewhere; so recheck all values looking for the missing parts. Color codes and printed numbers are difficult to read on many small parts, so special care is sometimes needed to avoid mix-ups.

GENERAL INFORMATION.

The R144 is a premium commercial grade single-channel vhf fm receiver, which features a helical resonator front end with low-noise dual-gate fet's, an 8-pole crystal filter plus a ceramic filter for superior i-f selectivity, hysteresis squelch circuit to lock onto fading signals, and automatic frequency control to compensate for off-frequency transmissions. The R144 kit is available for the 143-150 MHz band, and wired units are available for this band and also the 150-174 MHz commercial band.

CRYSTALS.

The channel crystal plugs into sockets identified in component location diagram as Y1. We can order crystals for any frequency desired. If you order your own, be sure to supply the following specs.

The receiver uses 32 pF parallel resonant crystals in HC-25/u holders. Crystals operate in the fundamental mode at a frequency of $(F-10.7)/9$. Frequency tolerance is .001%. We recommend that any new crystals be ordered directly from us to be sure that they will perform properly over the -30 to +60°C range for which the unit was designed. This is especially true for commercial receivers with the TCXO option, since the crystal must be matched exactly to the compensation circuit in the receiver. If you use an OV-1 crystal oven, specify a crystal with a 60°C breakpoint.

POWER CONNECTIONS.

The receiver operates on +13.6 Vdc at about 150 mA peak. Current drain with no audio is only about 40-50 mA. A crystal oven adds about 450 mA peak current drain when cold and only about 25 mA when warm. A well regulated power supply should be used.

Be sure that the power source does not carry high voltage or reverse polarity transients on the line, since semiconductors in the receiver can be damaged. Positive and negative power leads should be connected to the transmitter at E3 and E1, respectively. Be sure to observe polarity.

SPEAKER.

An 8-ohm loudspeaker should be connected to E2 with ground return to E1. Use of lower impedance speaker or shorting of speaker terminal can result in ic damage. The receiver can also drive higher impedances, like 1K to 10K input impedances of COR boards, etc.

There is no need to load down the output to 8 ohms.

ANTENNA CONNECTIONS.

The antenna connection should be made to the receiver with a phono plug. Use very short unshielded ends of coax at other end to connect to a "UHF" or "N" or "BNC" chassis jack if needed. We recommend a short length of RG-174/u coax and a good phono plug with cable clamp (see catalog). We do not recommend trying to use direct coax soldered to board or another type of connector. The method designed into the board results in lowest loss practical.

ALIGNMENT.

Equipment needed for alignment is an fet voltmeter, an rf signal generator, a regulated +13.6Vdc power supply with a 0-200 mA meter internally or externally connected in the supply line.

The slug tuned coils in the transmitter should be adjusted with the proper .062" square tuning tool to avoid cracking the powdered iron slugs. A tool is available as an accessory (model A28, \$2.50). Variable capacitors should be adjusted with a plastic tool with a small metal bit on the end. Tools for adjusting the variable capacitor (model A2, \$2.50) and transformer L2 (model A1, \$1.00) are also available.

The variable capacitor should be set to the center of its range (turn it 90°) if it has not previously been aligned. The squelch pot should be set fully counterclockwise.

a. Install channel crystal in socket Y1.

b. Connect speaker, ground, and +13.6 Vdc. You should hear white noise.

c. Connect dc voltmeter to TP1. Adjust first L4, then L3 and L4 alternately for maximum response. (Typical indication is +1.5 to 2.2Vdc.)

d. Connect stable signal generator to TP4 (gate-1 lead of Q2), using coax clip lead. Connect coax shield to pcb ground. Set generator to exactly 10.7000 MHz. Use a frequency counter or synthesized signal generator. Set level just high enough for full quieting. (At 1 uV, you should notice some quieting, but you need something near full quieting for the test.)

e. Adjust discriminator transformer L8 for +4Vdc with meter connected to AFC test point TP3. Note that the voltage changes very rapidly with tuning. Full AFC swing

of about 1.5 to 9V occurs within a few kHz, and a little drift may be noticed. It is only necessary to be within about 0.3V of 4V.

Note: There are two methods of adjusting the mixer and front end. One is to use an fet voltmeter with test point TP2, which is the rear lead of R21. The voltage at this point is proportional to the amount of noise detected in the squelch circuit; so it gives an indication of the quieting of the receiver. A signal peak, therefore, is indicated by minimum noise voltage.

The other method is to use a regular professional SINAD meter.

In either case, a weak to moderate signal is required to observe any change in noise. If the signal is too strong, there will be no change in the reading as tuning progress; so keep the signal generator turned down as the sensitivity of the receiver increases during tuning. If you use TP2 with a voltmeter, the signal can be modulated or unmodulated. If you use a SINAD meter, the standard method is a 1000 Hz tone with 3 kHz deviation.

f. Check that signal generator is still on 10.7000 MHz. With weak signal applied to Q2 gate-1 as before, adjust L2 for a peak. This step is critical to get lowest distortion in the crystal filter.

g. Reconnect signal generator to J1. Adjust to exact channel frequency, and turn output level up fairly high. Adjust frequency trimmer capacitor C16 to net the crystal to channel frequency, indicated by 4V at AFC test point TP3. If you can't find the signal at all, tune your signal generator up and down the band slightly. (Also check that oscillator is peaked as per step c.)

If your crystal has the wrong load correlation or is slightly out of tolerance, you may be able to compensate by changing the value of C15 so C16 can net the crystal on frequency. The AFC circuit will be pulling to counteract any adjustment you make on C16. You can observe this AFC action at TP3. The proper adjustment results in +4 Vdc, the same as preset for the exact 10.700 MHz i-f frequency earlier. After adjustment, you can tune the generator up and down to watch AFC action. You should be able to pull the carrier signal about 10 to 12 kHz high or low in frequency; and beyond that, you will notice a popping out of passband and the need to get within the i-f passband of +-7 kHz again for AFC to recapture the signal.

h. Connect fet dc voltmeter to TP2 (rear lead of R21). Set signal generator for relatively weak signal, one which shows a little change in the dc voltage indication. Alternately peak L5, L6, L7, and L1 until no further improvement can be made.

i. Helical resonator T2 supplied in the kit has been factory aligned to 145 MHz. Readjustment of the three screws may be necessary even if you are operating close to the preset frequency. Alternately adjust the three screws for best sensitivity.

Be careful not to adjust any screw more than just a few turns or you may unscrew the metal tuning slug from the end of its lead screw inside the resonator. If that should happen, you may be able to carefully disassemble the affected section and repair it.

When properly tuned, the sensitivity of the R144 should be about 0.15 μ V for 12 dB SINAD.

Following is a procedure which we use in the factory for fine tuning the AFC circuit after all other alignment is done. You may want to try it, although the improvement may only be minor. It helps to center the discriminator exactly in the center of the i-f passband. Connect fet voltmeter again to AFC test point TP3. With no input signal, only noise, adjust L8 (don't touch L2) for 4Vdc. Then, reapply full quieting signal at exact channel carrier frequency, and adjust crystal trimmer C16 for +4V.

DEFEATING THE AFC.

In some installations, such as 15 kHz splits, AFC may not be desirable. In such a case, you can remove varicap diode CR1 and replace it with a ceramic capacitor of about 12 pF.

SQUELCH CIRCUIT.

The squelch circuit has about 3 to 6 dB of hysteresis built in, so that once the squelch opens, the signal must drop 3 to 6 dB below the opening threshold before squelching again. This allows for some fading on mobile stations and prevents squelch pumping on heavy modulation. Of course, this requires setting the threshold a little higher than if there was no hysteresis so that it will close with no signal. If you prefer the older type squelch, you can simply remove Q5 from the circuit. If you want more or less hysteresis, you can decrease or increase the value of R25.

REPEATER USE.

E4 provides a "carrier operated switch" output which may be con-

nected to a COR module to turn a transmitter on and off. The output level is about 7V unscelched and 0V scelched. There is a 27K resistor in series with the output to limit current. Refer to COR module instructions for details.

MULTICHANNEL OPERATION.

An A24-144 Multichannel Adapter is available to provide operation on up to 5 channels. Refer to catalog for proper type to operate with this receiver. When the adapter is used, AFC operation is defeated, and ovens and TCXO option may not be used.

AUDIO MUTING.

If the receiver is used as a part of a transceiver, audio muting can be accomplished without switching the power or speaker lines. If the transmitter is keyed by applying B+ to the exciter, simply connect the keyed B+ through a 100K resistor to the junction of R25 and R27 on the receiver board. The dc level will be sufficient to trigger the squelch circuit in U2, regardless of the rf signal level coming into the receiver.

Of course, some means of disconnecting the receiver from the antenna must be provided, and we recommend our TRR Coax Relay Module if the power level is under 25 Watts. Otherwise, a larger coax relay will be required.

DISCRIMINATOR METER.

If you wish to use a discriminator meter and you are handy in designing with op-amps, you can run a sample of the dc voltage at the junction of R23 and C38 to one input of an op-amp and tie the other input to a voltage divider pot set to provide a reference voltage of about +4 Vdc. Values in the circuit depend on your meter and are beyond the scope of this discussion. (Sorry, we do not have a circuit, and there is no easy way to make an S-meter circuit.)

MOUNTING.

Some form of support should be provided under the pc board, generally mounting the board with spacers to a chassis. 3/8-inch holes should be provided in a front panel for the bushings of the SQUELCH and VOLUME controls. After sliding bushings through panel, washers and nuts are installed on the outside of the panel. Be sure to provide support for the board; do not rely on the controls to support the board. For repeater applications, the receiver should be mounted in an rf tight box, such as our model A16.

TROUBLESHOOTING.

The usual troubleshooting techniques of checking dc voltages and signal tracing work well in troubleshooting the receiver. A dc voltage chart and a list of typical audio levels are given to act as a guide to troubleshooting. Although voltages may vary widely from set to set and under various operating and measurement conditions, the indications may be helpful when used in a logical troubleshooting procedure.

The most common troubles in all kits are interchanged components, cold solder joints, and solder splashes. Another common trouble is blown transistors and ic's due to reverse polarity or power line transients. Remember if you encounter problems during initial testing that it is easy to install parts in the wrong place. Don't take anything for granted. Double check everything in the event of trouble.

If the receiver is completely dead, try a 10.700 MHz signal applied to TP4 with a coax cable clip lead. You should be able to hear the quieting effect of a 10 μ V carrier at 10.700 MHz. You can also connect the 10.700 MHz clip lead through a blocking capacitor to various sections of the crystal filter to see if there is a large loss of signal across one of the filter sections. Also, check the 10.245 MHz oscillator with a scope or by listening with an hf receiver or service monitor.

A signal generator on the channel frequency can be injected at various points in the front end. If the mixer is more sensitive than the rf amplifier, the rf stage is suspect. Check the dc voltages looking for a damaged fet. If audio is present at the volume control but not at the speaker, the audio ic may have been damaged by reverse polarity or a transient on the B+ line. If no audio is present on the volume control, the squelch circuit may not be operating properly. Check the dc voltages, and look for noise in the 10 kHz region, which should be applied to noise detector CR2 with no input signal. (Between pins 12 and 13 of U2 is an op-amp active filter tuned to 10 kHz.)

TYPICAL DC VOLTAGES.

The following dc levels were measured with an 11 megohm fet vm on a sample unit with 13.6 Vdc B+ applied. All voltages may vary considerably without necessarily indicating trouble. The chart should be used with a logical troubleshooting plan. All voltages are positive with respect to ground

except as indicated. Voltages are measured with no signal applied but oscillator running properly and with squelch open unless otherwise specified.

XSTR	E(S)	B(G1)	C(D)	G2
Q1	2	0	8	4
Q2	2	0	8	4
Q3	3.5	3	8.6	-
Q4	2.0	-0.06	13.6	-
Q5 Sq	0	0	0.7	-
Q5 Unsq	0	0.7	0	-
U1	$\frac{1}{7}$	$\frac{6}{0}$	$\frac{8}{6.5}$	$\frac{14}{13.6}$
U2	$\frac{1}{9.1}$	$\frac{2}{8.9}$	$\frac{3}{8.4}$	$\frac{4}{9.1}$ $\frac{5}{1.1}$
U2	$\frac{6}{1.1}$	$\frac{7}{1.1}$	$\frac{8}{9.1}$	$\frac{9}{5.4}$ $\frac{10}{4.5}$
U2	$\frac{11}{1 \text{ to } 9}$	$\frac{12}{2.5}$	$\frac{13}{2.5}$	$\frac{14}{0.3 \text{ to } 0.7}$
U2	$\frac{15}{0(SQ), 8.5(UNSQ)}$	$\frac{16}{0}$	$\frac{17}{0}$	$\frac{18}{2.2}$

TYPICAL AUDIO LEVELS.

Following are rough measurements of audio circuits, using an 11 meg-ohm fet vm. Measurements were taken with no input signal, just white noise so conditions can be reproduced easily.

U2 pin 10: 400 mV rms
 U2 pin 13: 2V rms
 Top of volume control: 200 mV rms
 Across 8 ohm spkr term: 3.5 Vrms

PARTS LIST FOR R144 RECEIVER.

REF #	VALUE (MARKING)
C1	22 pf
C2	39 pf
C3-C4	Feedthrough Capacitor
C5-C6	220 pf (221)
C7-C8	Feedthrough Capacitor
C9	.01 uf (103)
C10	220 pf (221)
C11-C13	4 pf
C14	.001 uf (102)
C15	27 pf
C16	20 pf (red) variable cap
C17-C18	150 pf (151)
C19	.01 uf (103)
C20	62 pf
C21	1 pf
C22	not assigned
C23	62 pf
C24	.01 uf (103)
C25-C26	220 pf (221)
C27	18 pf
C28	0.5 pf
C29	22 pf
C30	0.5 pf
C31	22 pf
C32	1 pf
C33	100 uf electrolytic
C34	470 uf electrolytic
C35	33 uf electrolytic
C36	.01 uf (103)
C37	0.47 uF electrolytic

C38	.01 uf (103)
C39	Not assigned
C40-C41	680 pf (681)
C42-C43	0.47 uF electrolytic
C44	33 pf
C45	470 pf (471)
C46-C48	0.47 uF electrolytic
C49	100 pf (101)
C50	0.47 uf electrolytic
CR1	MV2101 varicap (6.8 pf)
CR2	1N4148 (may not be marked)
FL1-FL4	Matched xtal filter set
FL5	Ceramic filter (blue)
J1	RCA jack
L1	2-11/2 turns (red)
L2	KAC-6184 IF transformer
L3-L4	6-1/2 turns (blue)
L5-L7	2-1/2 turns (red)
L8	831-5 IF transformer
Q1-Q2	N.E.C. 41137 GaAs FET (static handling precautions required)
Q3	2N4124
Q4	2N3563
Q5	2N4124
R1-R2	100K
R3	180 ohms
R4	470 ohms
R5-R6	100K
R7	180 ohms
R8	4.7K
R9	470 ohms
R10	180 ohms
R11	100 ohms
R12-R13	15K
R14	680 ohms
R15	47K
R16	330K
R17	Not used
R18	470 ohms
R19	2 Meg
R20	100K pot
R21	100K
R22	100K pot
R23	27K
R24	150K
R25	330K
R26	27K
R27	150K
R28	330K
R29	1.2K
R30	not used
R31	47K
R32	15K
T1	Toroid: Primary 10 turns; secondary 2 turns
T2	Helical Resonator #1008
T3	Toroid: Primary 10 turns; secondary 3 turns
U1	LM-380N
U2	MC-3359P
VR1	1N5239B
Y1	Channel xtal (see text)
Y2	10.245 MHz if crystal
Z1-Z3	Ferrite beads

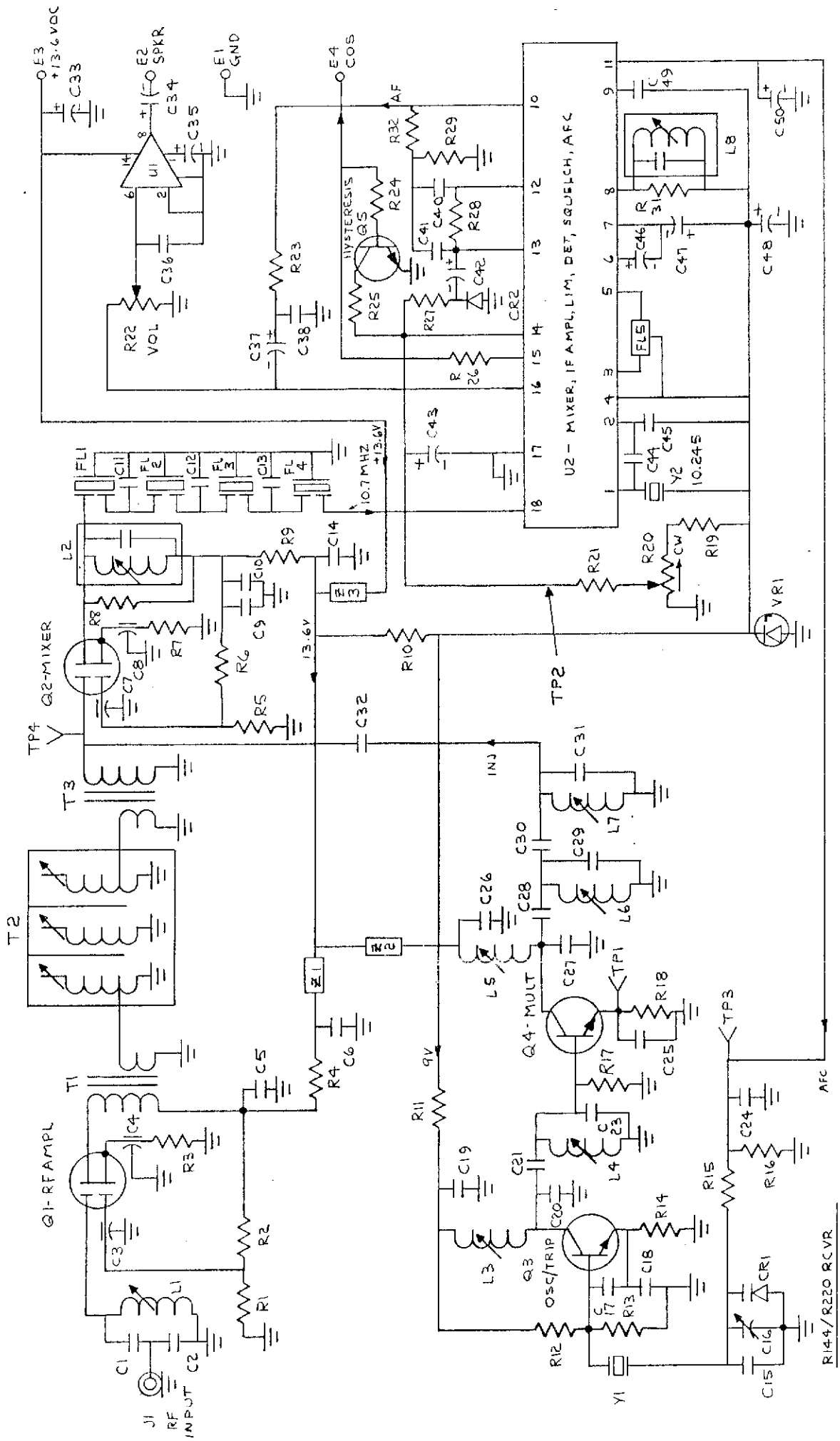

R144/R220 RCVR

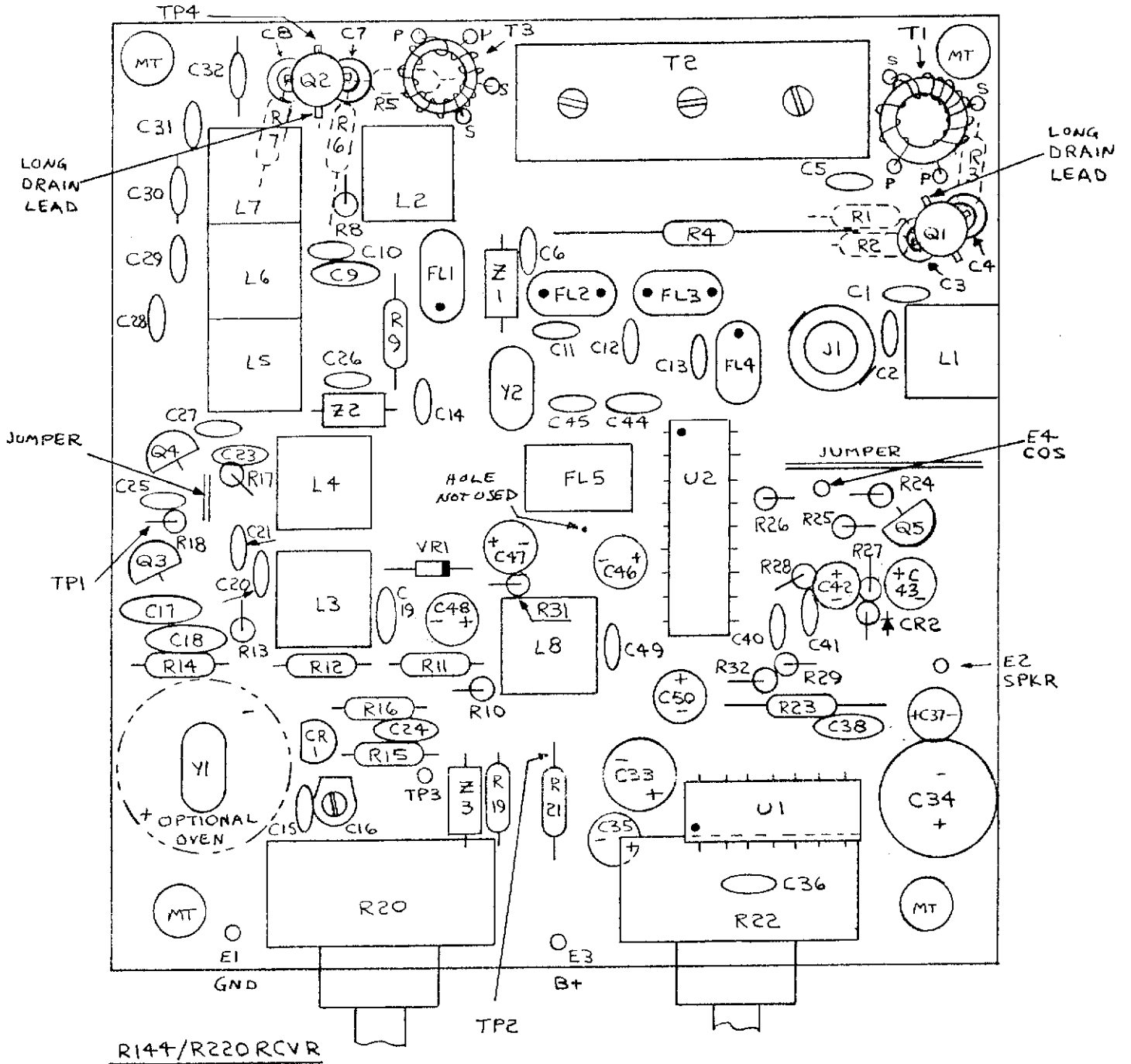
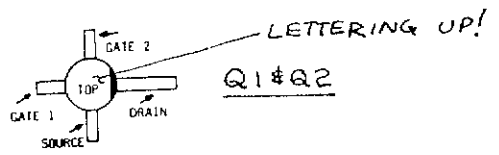

R144/R220RCVR