

HAMTRONICS® TA51 VHF FM EXCITER: INSTALLATION, OPERATION, & MAINTENANCE

GENERAL INFORMATION.

The TA51-144 is a single-channel vhf fm exciter designed to provide 2 Watts continuous duty output into a 50 ohm antenna system in the 144 MHz ham band or the 148-175 MHz commercial band. The TA51-220 is a similar model to cover the 213-233 MHz ham and government bands. The TA51-50 covers the 50-54 MHz ham band. The TA51-72 covers 72-76 MHz.

They are designed for narrow-band fm with 5 kHz deviation. Audio input is designed to accept a standard low-impedance dynamic microphone or any low-impedance audio source capable of providing 30mV p-p into a 2K load. Operating power is +13.6 Vdc +/-10% at 450-500 mA.

The sequence of presentation of the following information assumes that you purchased a wired exciter, ready to operate. If you purchased a kit, refer to page 2 for Alignment instructions prior to performing audio level or frequency adjustments.

CRYSTALS.

The TA51 uses 32 pF parallel resonant crystals in HC-25/u holders. Crystals operate in the fundamental mode at a frequency of:

- F/12 for TA51-144
- F/18 for TA51-220
- F/4 for TA51-50
- F/6 for TA51-72

This normally results in a crystal frequency in the 12-13 MHz area.

We recommend that crystals be ordered directly from us to be sure that they will perform properly over the -30 to +60°C range for which the unit was designed. If you buy crystals elsewhere, make sure you get only the highest quality commercial grade crystals to avoid problems later on.

If you use an OV-1 crystal oven, specify a crystal with a 60°C break-point. The crystal is inserted into sockets on the board. The oven is installed on the board over the crystal, observing polarity by matching the 3-lead pattern to the holes in the board (see component location diagram). Then, the pins of the oven are soldered to the board.

POWER.

The TA51 Exciter operates on

+13.6Vdc at about 450-500 mA. A well regulated power supply should be used. Positive and negative power leads should be connected to the exciter at E1 and E3. Be sure to observe polarity. If a crystal oven is used, +13.6Vdc should be connected to the oven via E4 from a supply line separate from E1, since E1 is keyed on and off to transmit. Oven power should remain on constantly during any period when transmission is expected.

MOUNTING.

The four mounting holes provided near the corners of the board can be used in conjunction with screws and standoffs to mount the board in any cabinet or panel arrangement. (See catalog for A26 PC Mounting Kits.) There is no need for a shielded cabinet except if the exciter is used in a repeater or in duplex service.

KEYING.

The easiest way to key the exciter is to run the B+ for the unit (E1) through the push-to-talk switch in the microphone or a similar spst switch. Although a relay may be used, it is not necessary; since the 450-500 mA required by the exciter may easily be switched by most microphone switches. If you are interfacing with some sort of control board, a PNP transistor, such as a TIP-30, can be used to switch the current to operate the exciter. If a class-C power amplifier is driven by the exciter, the pa will draw current only when the TA51 exciter is driving it with rf power; so the pa should not require a separate keyline circuit.

AUDIO CONNECTIONS.

The TA51 Exciter is designed for use with a low impedance dynamic microphone (500-1000 ohms) or any low impedance audio source capable of supplying 30 mV p-p across 2000 ohms. The microphone should be connected with shielded cable to avoid noise pickup. Mic connections are made to E2 and E3 on the pc board. *Be sure to dress the audio cable away from the piston capacitor; since close proximity could affect channel frequency.*

AUDIO DEVIATION ADJUSTMENTS.

To adjust the audio controls, start by setting potentiometer R20 to maximum and R3 to midrange. Apply B+ to E1 to key the exciter and talk into the microphone or apply audio of normal expected level to the exciter. If the unit is setup with tones from a service monitor, use a tone frequency of 1000 Hz. Observe the deviation meter or the scope on a service monitor, and adjust R20 for a peak deviation of 5 kHz. Then, adjust mic gain control R3 so that the exciter deviation just swings up to 5 kHz on modulation peaks.

This will provide the optimum setting, with sufficient audio gain to achieve full modulation but with the limiter occasionally clipping voice peaks to prevent over-modulation. Avoid setting the audio gain higher than necessary. Although the deviation limiter will prevent over-modulation, microphone background noise is increased and some distortion from excessive clipping may result.

Note that when the exciter is used in repeater service, instructions in the manuals for the COR and Autopatch modules should be used to set the exciter audio controls, since each repeater system requires a specific audio adjustment method.

FREQUENCY ADJUSTMENT.

The crystal frequency is precisely set on the channel frequency with piston trimmer capacitor C13, using an accurate service monitor or frequency counter.

Note that the tuning range of piston capacitor C13 was deliberately limited to provide optimum frequency stability. With some crystals, the frequency may not be adjustable high enough. If this is the case, clip the jumper to disconnect C63 from the circuit, which raises the frequency range of the variable capacitor.

SUBAUDIBLE TONES.

If you want to transmit a CTCSS (subaudible) tone, you can connect the output of the tone encoder through a 10K resistor directly to the audio input of the exciter. (Our TD-3 Tone Decoder/Encoder module already has a resistor on board; so it

does not require an extra resistor.) If you prefer to inject the CTCSS tone after the audio circuits in the exciter, you can inject it through a large resistor into the junction of R21 and R22. The level of the subaudible tone should be set no higher than about 300 Hz deviation for best results. Otherwise, a buzz may be heard on the audio at the receiver.

THEORY OF OPERATION.

The TA51 is a fairly straight forward fm exciter, with a phase modulated 12 MHz signal multiplied up to reach the desired output range. Crystal oscillator Q1 operates as a Colpitts oscillator at the fundamental frequency of approximately 12 MHz. When supplied with TCXO option, a thermistor compensates for cold temperatures by gradually reducing the amount of load capacitance in series with the crystal at temperatures below +10 degrees C. The oscillator output is fed into reactance modulator Q2, which phase modulates the carrier with audio from the speech processor circuits.

For the 144 MHz ham band or the high commercial band, Q3 operates as a tripler to multiply the carrier frequency to a range of about 36 MHz. Q4 doubles this to arrange of about 72 MHz. This, in turn, is doubled again in Q5 to range of about 144 MHz, which is the final output frequency.

For the 220 MHz band, Q3 operates as a tripler to multiply the carrier frequency to a range of about 36 MHz. Q4 triples this again to arrange of about 110 MHz. This, in turn, is doubled in Q5 to range of about 220 MHz.

For the 50-54 MHz ham band, Q3 and Q4 each act as doublers, from 13 to 26 to 52 MHz. Q5 is not used.

Q6 acts as a predriver amplifier. The signal is further amplified by driver Q7 and output amplifier Q8 to provide the 2 Watt output signal to the 50 ohm antenna. Spurious signal rejection is provided by double tuned circuits between multiplier stages and two low pass filters in the output of the pa stage.

The audio processor circuits consist of microphone amplifier U1-A and U1-B, peak limiter CR1-CR2, amplifier U1-D, and active filter U1-C. The audio input, at a level of about 30 mV p-p, is amplified and applied to the limiter circuit. R3 provides adjustment of the audio gain of the first op-

amp. Processed audio, limited in peak amplitude, contains a small amount of harmonic distortion from the clipping process. Active filter U1-C is a low pass filter which greatly reduces the effects of any distortion from the limiter to prevent splatter of sidebands outside the bandwidth allowed for one channel. Deviation potentiometer R20 allows for adjustment of the peak audio level applied to modulator Q2. C11-R23 is an rf filter to keep the 12 MHz carrier signal from getting back into the active filter stage. R21-C10-R22-C11 acts as an additional low pass filter. Together with the active filter stage, it provides a 12 dB/octave rolloff for any frequencies over 3000 Hz.

Dc power for the exciter is applied at E1 when the unit is required to transmit. +13.6 Vdc is applied to all stages, except the oscillator, modulator, and audio stages. A 9.1 Vdc regulator provides power for those stages for stability of the carrier frequency under varying input voltages and for noise and hum filtering. Power supplied through R45 is regulated by zener diode VR1 and filtered by C60 to isolate the sensitive stages from the outside world.

ALIGNMENT.

Equipment needed for alignment is a voltmeter, a good uhf 50 ohm rf dummy load, a relative output meter, and a regulated 13.6Vdc power supply with a 0-1000 mA meter internally or externally connected in the supply line.

The slug tuned coils in the exciter should be adjusted with the proper .062" square tuning tool to avoid cracking the powdered iron slugs. (See A28 tool in catalog.) All variable capacitors should be set to the center of their range (turn them 90 degrees) if they have not previously been aligned.

⊗ **NOTE:** *Following are some ground rules to help avoid trouble. Always adhere to these guidelines.*

1. *Do not operate without a 50 ohm load.*

2. *Do not exceed 2 Watts output (500 mA total current drain) for continuous duty operation. Do not exceed 2.5 Watts output (600 mA total current drain) for even momentary operation. Reduce drive slightly, if necessary, by detuning L8.*

3. *Always follow alignment procedure exactly. Do not peak all controls for maximum output. Each multi-*

plier stage has its own best monitoring test point for maximum drive to the following stage.

4. *Rf power transistors Q7 and Q8 run quite warm at full drive, but not so hot that you can't touch them without being burned. Never run the unit without Q8 heatsink in place.*

a. Connect 50 ohm dummy load to phono jack J1 through some form of relative output meter.

b. Check output voltage of power supply, adjust it to 13.6 Vdc, and connect it to B+ terminal E1 and ground terminal E3 on the pc board. It is permissible to use the braid of the coax cable or the mounting hardware to the chassis as a ground if the power supply has a good low-impedance connection through this path to the ground on the board. **BE SURE TO OBSERVE POLARITY!** A 1000 mA meter or suitable equivalent should be connected in the B+ line to monitor current drawn by the exciter. This is important to indicate potential trouble before it can overheat transistors. Better yet, if using a lab supply for testing, set the current limiter on the power supply to limit at 600 mA.

Note: Meter indications used as references are typical but may vary widely due to many factors not related to performance, such as type of meter and circuit tolerances. Typical test point indications are for the 144 MHz or high band unit and may differ for other bands.

c. Connect voltmeter to TP2 (top lead of R35). Peak L2 and L3 alternately for maximum indication. Typical reading is about +0.8 to 1.2 Vdc.

d. Connect voltmeter to TP3 (top lead of R37). Peak L4 and L5 alternately for maximum indication. Typical reading is about +0.8 to 1.2 Vdc.

e. Connect voltmeter to TP4 (top lead of R40). Peak L6 and L7 alternately for maximum indication. Typical reading is about +0.4 to 0.9 Vdc.

f. At this point, you should have a small indication on the relative power meter. Alternately peak L8, C51, C53, and C56 for maximum indication on the power meter. Note that there are interactions between these adjustments, especially between tune capacitor C53 and loading capacitor C56; so it may be necessary to try several combinations to find the optimum settings. When peaking C53 and C56, it helps to observe dc current drain to find adjustment combination giving maximum output with minimum cur-

rent drain (best efficiency).

g. At full drive, the total current drawn by the exciter should be 450-500 mA, and the rf output should be about 2 Watts. Do not operate at a level above 550 mA on a continuous basis, but up to 600 mA is ok on a 50% duty cycle. Although it may be possible to drive some units up to 3 Watts or greater, to prevent overheating, do not exceed 2-1/2 Watts output or 600 mA current drain for even momentary operation. The drive level may be reduced, if necessary, by detuning L8 slightly.

Note that full output may not be possible with less than 13.6 Vdc B+. Power output falls rapidly as operating voltage is reduced. This does not necessarily mean that the unit cannot be used on lower B+ voltage, however, since it is hard to distinguish even a 2:1 reduction in power on the air.

After tuning the exciter into a known good 50 ohm dummy load, it should not be retuned when later connected to the antenna or power amplifier. Of course, the antenna or pa should present a good 50 ohm load to the exciter.

h. Perform the carrier frequency and audio level adjustments given on page 1 to complete the alignment of the exciter.

Note: *If the audio sounds raspy, the first multiplier stage may be out of alignment; try repeaking L2 and L3 as described in step c.*

POWER ADJUSTMENT.

The drive level to the output stage can be adjusted somewhat by detuning L8, which will lower the power to about 1/2 without causing spurious outputs. If you need to reduce the level further, C51 can be detuned slightly to reduce the output to around 1/3 Watt. Note, however, that reducing the drive to a class-C amplifier

can result in spurious signals if the drive is reduced too far. Other ways to reduce output without running this risk are to reduce the B+ voltage to around 11Vdc or using an attenuator after the exciter output.

TROUBLESHOOTING.

The usual troubleshooting techniques of checking dc voltages and signal tracing with an rf voltmeter probe will work well in troubleshooting the TA51. A dc voltage chart and a list of typical audio levels are given to act as a guide to troubleshooting. Although voltages may vary widely from set to set and under various operating and measurement conditions, the indications may be helpful when used in a logical troubleshooting procedure. The exciter should draw about 30-50 mA at idle, with the crystal pulled out, and about 500-550 mA at full output.

Be careful, when operating or troubleshooting, to avoid driving the unit to levels over 2 Watts or operating the unit at dc current drain levels over 500 mA for extended periods. Keep an eye on an ammeter in the B+ line while tuning. Do not exceed 2-1/2 Watts output (550 mA total current drain) for even momentary operation. Reduce the drive, if necessary, by detuning L8 slightly.

If you replace the output transistor for any reason, be sure to space the metal can about 1/32 inch above the pc board ground plane to avoid grounding the case, which is connected to the collector. Do not use any dielectric material under the transistor other than air.

TYPICAL DC VOLTAGES.

The following dc levels were measured with an 11 megohm fet vm on a sample unit with 13.6 Vdc B+ applied. All voltages may vary considerably without necessarily indicating trouble. The chart should be used with a logical troubleshooting plan. All voltages are positive with respect to ground except as indicated. Voltages are measured with crystal plugged in and oscillating

exciter fully tuned to provide 2W output. Note that meter probe must have 1 megohm or similar resistor in probe to isolate from rf signals. Even then, the type of meter and probe has an effect on the readings taken on points where rf is present.

STAGE	E	B	C
Q1	3.7	3.0	8.5
Q2	2.3	3.0	5.5
Q3	0.9	1.5	13.6
Q4	0.9	-0.35	13.6
Q5	0.9	-1.4	13.6
Q6	0.6	-0.5	varies
Q7	0	-0.14	13.6
Q8	0	n/a	13.6
U1 pins 1,2,3,6,8,11,12,13:			0.55V
U1 pins 4, 5, 9, 10:			4.6V
U1 pin 14:			9.1V

TYPICAL AUDIO VOLTAGES.

Following are rough measurements of audio voltages (in mV p-p) which may be measured with a sensitive voltmeter or an oscilloscope when a low impedance dynamic microphone or other audio source is connected and modulating to full 5 kHz deviation. Measurements given were taken with an oscilloscope with mic gain and deviation controls fully cw and sufficient audio input applied for full deviation of the rf signal. Measurements are typical of what might be indicated during a sustained whistle or with an audio signal generator. Of course, readings may vary widely with setup; but levels given are useful as a general guide. Note: if rf affects oscilloscope pattern, unplug crystal.

Test Point	mV p-p
E2 AF input	10
U1-4	50
U1-5	400
CR2 cathode at R12 top	400
U1-10	700
U1-9	1000
Top of R23	220

PARTS LIST FOR TA51-144 [TA51-220].

Note: Capacitor values for 150-174 MHz may be slightly lower. Values which differ for the TA51-220 are shown in *[brackets]*. See sidebar for special values for the 160-173MHz sub-band.

Ref Desig	Value	(marking)
C1	.001 uf (102, 1nM, or 1nK)	
C2	1 uf electrolytic	
C3	.01 uf disc (103)	
C4	4.7 uf electrolytic	
C5	470 pf (471)	
C6	1 uf electrolytic	
C7	470 pf (471)	
C8	39 pf	
C9	1 uf electrolytic	
C10-C11	.01uf disc (103)	
C12	43 pf	
C13	10 pf piston trimmer	
C14	150 pf (151)	
C15	110 pf (111)	
C16	39 pf	
C17	150 pf (151)	
C18-C20	.01uf disc (103)	
C21	220 pf (221)	
C22	47 uF electrolytic	
C23	.001 uf (1nK or M) [120 pf]	
C24	.001 uf (102, 1nM, or 1nK)	
C25	.001 uf (102, 1nM, or 1nK)	
C26	110 pf (111)	
C27	.001 uf (102, 1nM, or 1nK)	
C28	.01 uf disc (103)	
C29	2 pf	
C30	.0022 uf (2n2K or 2.2nK)	
C31	110 pf (111)	
C32-C33	.001 uf (102, 1nM, or 1nK)	
C34	22 pf [8 pf]	
C35	0.5 pf	
C36	39 pf [12 pf]	
C37	62 pf [27 pf]	
C38	120 pf	
C39	.001 uf (1nK or M) [120 pf]	
C40	15 pf [5 pf]	
C41	0.5 pf	
C42	27 pf [10 pf]	
C43	39 pf [18 pf]	
C44	120 pf	
C45	.001 uf (1nK or M) [120 pf]	
C46	.0022 uf (2n2K or 2.2nK)	
C47	15 pf [4 pf]	
C48	62 pf [33pf]	
C49	120 pf	
C50	10 pf [4 pf]	
C51	30 pf green variable cap [20 pf pink variable cap]	
C52	.001 uf (1nK or M) [120 pf]	
C53	60 pf brown variable cap [20 pf pink variable cap]	

C54	.001 uf (1nK or M) [120 pf]
C55	4.7 uF electrolytic
C56	30 pf green variable cap [7 pf blue variable cap]
C57	43 pf [15 pf]
C58	39 pf [20 pf]
C59	.001 uf (1nK or M) [120 pf]
C60	4.7 uF electrolytic
C61	39 pf
C62	.01 uf disc (103)
C63	not used
CR1-CR2	1N4148 (may be unmarked)
J1	RCA Jack
L1	not assigned
L2-L5	6-1/2 turns (blue)
L6-L8	2-1/2 turns (red)
L9	0.33 uH choke (red-sil-orn-orn)
L10	2-1/2 turns(red), no slug
L11	0.33 uH choke, (red-sil-orn-orn)
L12-L14	2-1/2 turns(red), no slug
Q1-Q6	2N5770
Q7	2N5770 [Motorola MPS3866]
Q8	Phillips BLX-65
R1	2.2K
R2	100K
R3	1 meg pot (105)
R4	510K
R5	1 meg
R6	47K
R7	1 meg
R8	510K
R9	1.2K
R10	10K
R11	1.2K
R12	68K
R13	100K
R14	1 meg
R15	510K
R16	330K
R17	510K
R18	150K
R19	680K
R20	20K pot (203) or 22K pot (223 or 22K)
R21-R22	4.7K
R23	10K [15K]
R24	100 ohms
R25	10K
R26	4.7K
R27	270 ohms
R28	15K
R29	10K
R30	2.2K
R31	27K
R32	4.7K
R33	270 ohms [180 ohms]
R34	not used
R35	270 ohms [100 ohms]
R36	3.3K

R37	100 ohms
R38	not used
R39	1.2K
R40	47 ohms
R41	2.2K
R42	27 ohms [100 ohms]
R43	not used
R44	27 ohms
R45	100 ohms
R46	2.2K
R47	2.2K
RT1	Thermistor (used only with TCXO option)
U1	3301 (can substitute 3401 or 3900)
VR1	1N5239B 9.1 V zener
Z1-Z9	Ferrite bead, prestrung

Special values for the 160-173MHz sub-band. Substitute these for standard values shown at left.

C26	82 pf
C31	82 pf
C34	20 pf
C36	33 pf
C40	10 pf
C42	22 pf
C43	27 pf
C47	10 pf
C48	47 pf
C57	33 pf
C58	27 pf

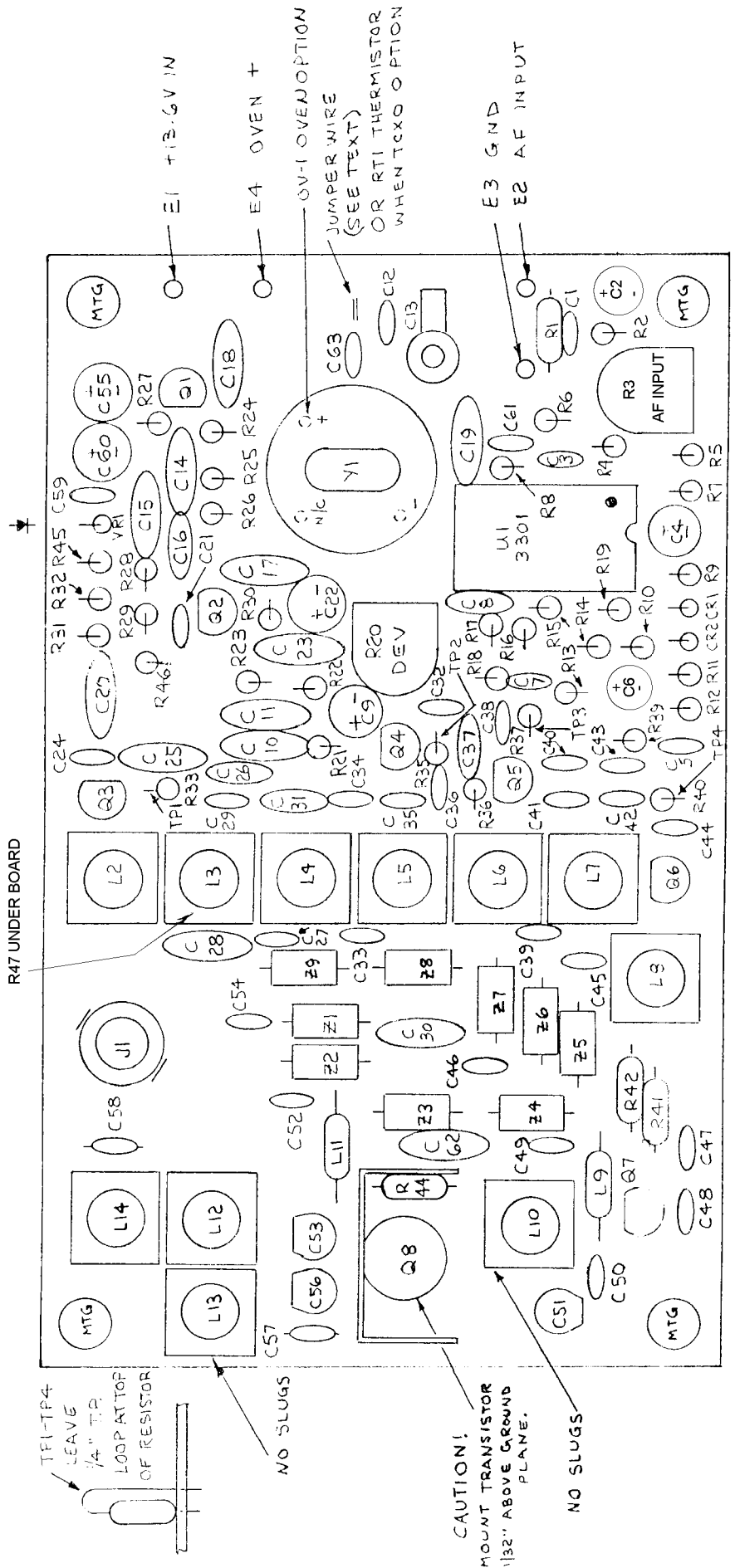

TA-51

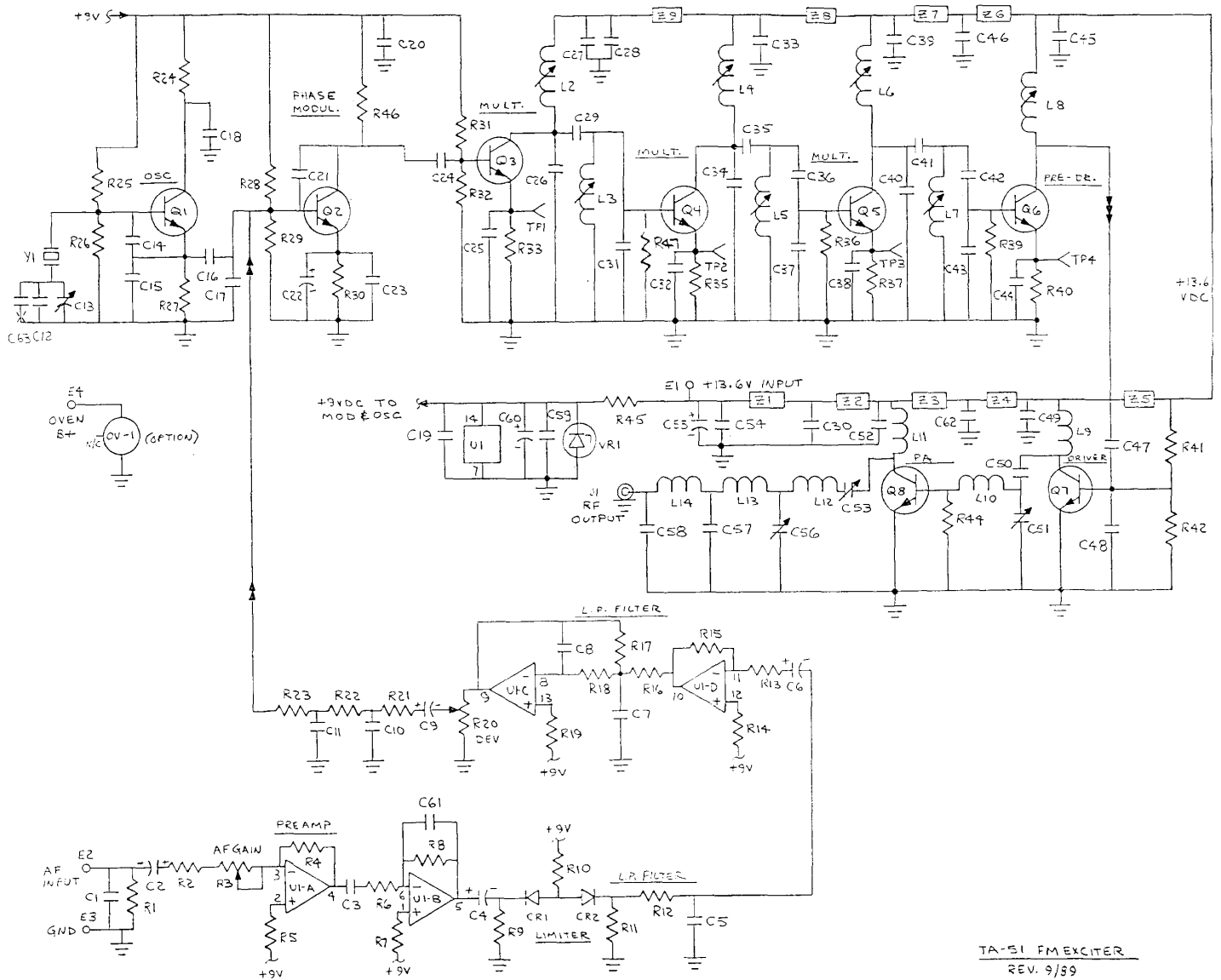

TA-51 FM EXCITER
REV. 9/89

PARTS LIST FOR TA51-50.

Note: Because stage Q5 on the pc board is not used for the 50MHz version of the TA51, it is important to note certain information at the bottom of the page before doing assembly or alignment. Also, some parts are not installed in this model; they are marked "not used" on the parts list.

Ref Desig	Value	(marking)
C1	.001 uf (102, 1nM, or 1nK)	
C2	1 uf electrolytic	
C3	.01 uf disc (103)	
C4	4.7 uf electrolytic	
C5	470 pf (471)	
C6	1 uf electrolytic	
C7	470 pf (471)	
C8	39 pf	
C9	1 uf electrolytic	
C10-C11	.01uf disc (103)	
C12	43 pf	
C13	10 pf piston trimmer	
C14	150 pf (151)	
C15	110 pf (111)	
C16	39 pf	
C17	150 pf (151)	
C18-C20	.01uf disc (103)	
C21	220 pf (221)	
C22	47 uF electrolytic	
C23-C24	.001 uf (102, 1nM, or 1nK)	
C25	.001 uf (102, 1nM, or 1nK)	
C26	56 pf	
C27	.001 uf (102, 1nM, or 1nK)	
C28	.01 uf disc (103)	
C29	1 pf	
C30	.0022 uf (2n2K or 2.2nK)	
C31	56 pf	
C32-C33	.001 uf (102, 1nM, or 1nK)	
C34	62 pf	
C35	1 pf	
C36-C38	not used	
C39	.001 uf (102, 1nM, or 1nK)	
C40-C41	not used	
C42-C43	110 pf (111)	
C44-C45	.001 uf (102, 1nM, or 1nK)	
C46	.0022 uf (2n2K or 2.2nK)	
C47	82 pf	
C48	150 pf (151)	
C49	.001 uf (102, 1nM, or 1nK)	
C50	10pf	
C51	60 pf brown variable cap	
C52	.001 uf (102, 1nM, or 1nK)	
C53	60 pf brown variable cap	
	➡ Tack solder 43 pf disc across C53 under board.	
C54	.001 uf (102, 1nM, or 1nK)	
C55	4.7 uF electrolytic	
C56	60 pf brown variable cap	
C57	68 pf	
C58	56 pf	
C59	.001 uf (102, 1nM, or 1nK)	
C60	4.7 uF electrolytic	
C61	39 pf	
C62	.01 uf disc (103)	
C63	not used	
CR1-CR2	1N4148 (may be unmarked)	

J1	RCA Jack
	➡ Be careful not to interchange coils with the same color but different windings, eg., 9-1/2 turns tight-wound and space-wound.
L1	not assigned
L2-L3	14-1/2 turns <i>tight-wound</i> (yellow)
L4	6-1/2 turns <i>space-wound</i> (blue)
L5-L6	not used
L7	6-1/2 turns <i>space-wound</i> (blue)
L8	6-1/2 turns <i>space-wound</i> (blue)
L9	0.33 uH choke (red-sil-orn-orn)
L10	0.22 uH choke (red-sil-red-red) ➡ Note: Shield can and holes for its lugs are not used.
L11	0.33 uH choke, (red-sil-orn-orn). ➡ Note: Tack solder a 1.2K resistor across L11 on the rear of the board with short leads.
L12-L14	0.33 uH choke (red-sil-orn-orn) ➡ Note: Shield cans and holes for their lugs are not used. Chokes are mounted horizontally, close to board.
Q1-Q3	2N3904 or 2N4124
Q4	2N3563
Q5	not used
Q6-Q7	2N3904 or 2N4124
Q8	Philips BFS-22A
R1	2.2K
R2	100K
R3	1 meg pot (105)
R4	510K
R5	1 meg
R6	47K
R7	1 meg
R8	510K
R9	1.2K
R10	10K
R11	1.2K
R12	68K
R13	100K
R14	1 meg
R15	510K
R16	330K
R17	510K
R18	150K
R19	680K
R20	20K pot (203) or 22K pot (223 or 22K)
R21-R22	2.2K
R23	10K
R24	100 ohms
R25	10K
R26	4.7K
R27	270 ohms
R28	15K
R29	10K
R30	2.2K
R31	27K

R32	4.7K
R33	270 ohms
R34	not used
R35	270 ohms
R36-R38	not used
R39	680 ohms
R40	47 ohms
R41	2.2K
R42	27 ohms
R43	not used
R44	10 ohms
R45	100 ohms
R46	2.2K
R47	2.2K
RT1	Thermistor (used only with TCXO option)
U1	3301 (can substitute 3401 or 3900)
VR1	1N5239B 9.1 V zener
Z1-Z9	Ferrite bead, prestrung

➡ IMPORTANT!

- Be sure all the required parts are tack soldered under the board as called for in the parts list!
- Q5 and its associated components are not used.
- A jumper must be added, using #22 bus wire (lead clipping). Looking at the component location diagram, connect it from the pad marked for the left lead of C36 to the pad marked for the bottom lead of C41. (These caps are not used.) The jumper should be as short and direct as possible. The jumper has the electrical effect of making C35 a coupling capacitor between L4 and L7, in effect using C35 to also take over the function of C41, which is not used.
- Please mark schematic and component location diagrams with deleted parts and added jumper wire.
- The multiplier chain operates as follows: the 13 MHz oscillator signal is doubled to 26 MHz in Q3 and doubled again to 52 MHz in Q4.
- Note that some dc test voltages may be a little different from those shown in the troubleshooting charts for 144 MHz sample used in original instruction manual.
- Be sure to preset all variable capacitors to mid-range before alignment to avoid false peaks.
- L4 and L7 are tuned alternately as a pair, using test point TP4. TP3 is not used.
- Because the fundamental frequency is only multiplied by 4 (instead of 12 for 144 MHz), the frequency deviation is only 1/3 of what it would be on high-band. Therefore, it may not be possible to obtain a full ± 5 kHz deviation with modulation without a little distortion. This should not be objectionable though.

PARTS LIST FOR TA51-72.

Note: Because stage Q5 on the pc board is not used for the 72-76MHz version of the TA51, it is important to note certain information at the bottom of the page before doing assembly or alignment. Also, some parts are not installed in this model; they are marked "not used" on the parts list.

Ref Desig	Value	(marking)
C1	.001 uf (102, 1nM, or 1nK)	
C2	1 uf electrolytic	
C3	.01 uf disc (103)	
C4	4.7 uf electrolytic	
C5	470 pf (471)	
C6	1 uf electrolytic	
C7	470 pf (471)	
C8	39 pf	
C9	1 uf electrolytic	
C10-C11	.01uf disc (103)	
C12	43 pf	
C13	10 pf piston trimmer	
C14	150 pf (151)	
C15	110 pf (111)	
C16	39 pf	
C17	150 pf (151)	
C18-C20	.01uf disc (103)	
C21	220 pf (221)	
C22	47 uF electrolytic	
C23-C24	.001 uf (102, 1nM, or 1nK)	
C25	.001 uf (102, 1nM, or 1nK)	
C26	110 pf (111)	
C27	.001 uf (102, 1nM, or 1nK)	
C28	.01 uf disc (103)	
C29	2 pf	
C30	.0022 uf (2n2K or 2.2nK)	
C31	110 pf (111)	
C32-C33	.001 uf (102, 1nM, or 1nK)	
C34	22 pf	
C35	0.5 pf	
C36-C38	not used	
C39	.001 uf (102, 1nM, or 1nK)	
C40-C41	not used	
C42	39 pf	
C43	62 pf	
C44-C45	.001 uf (102, 1nM, or 1nK)	
C46	.0022 uf (2n2K or 2.2nK)	
C47	33 pf	
C48	110 pf	
C49	.001 uf (102, 1nM, or 1nK)	
C50	15pf	
C51	50pf orange variable cap	
C52	.001 uf (102, 1nM, or 1nK)	
C53	50pf orange variable cap	
C54	.001 uf (102, 1nM, or 1nK)	
C55	4.7 uF electrolytic	
C56	50 pf orange variable cap	
C57	82 pf	
C58	68 pf	
C59	.001 uf (102, 1nM, or 1nK)	
C60	4.7 uF electrolytic	
C61	39 pf	
C62	.01 uf disc (103)	
C63	not used	
CR1-CR2	1N4148 (may be unmarked)	
J1	RCA Jack	
L1	not assigned	

L2-L4	6½ turns (blue)
L5-L6	not used
L7-L8	6½ turns (blue)
L9	1 uH choke (no marking)
L10	6½ turns (blue), no slug
L11	1 uH choke (no marking)
L12-L14	6½ turns (blue), no slug
Q1-Q4	2N3904
Q5	not used
Q6	2N3904
Q7	2N3563
Q8	Philips BLX-65
R1	2.2K
R2	100K
R3	1 meg pot (105)
R4	510K
R5	1 meg
R6	47K
R7	1 meg
R8	510K
R9	1.2K
R10	10K
R11	1.2K
R12	68K
R13	100K
R14	1 meg
R15	510K
R16	330K
R17	510K
R18	150K
R19	680K
R20	20K pot (203) or 22K pot (223 or 22K)
R21-R22	4.7K
R23	10K
R24	100 ohms
R25	10K
R26	4.7K
R27	270 ohms
R28	15K
R29	10K
R30	2.2K
R31	27K
R32	4.7K
R33	270 ohms
R34	not used
R35	270 ohms
R36-R38	not used
R39	1.2K
R40	47 ohms
R41	2.2K
R42	27 ohms
R43	not used
R44	27 ohms
R45	100 ohms
R46	2.2K
R47	2.2K
RT1	Thermistor (used only with TCXO option)
U1	3301 (can substitute 3401 or 3900)
VR1	1N5239B 9.1 V zener
Z1-Z9	Ferrite bead, prestrung

➔ IMPORTANT!

- Q5 and its associated components are not used.
- A jumper must be added, using #22 bus wire (lead clipping). Looking at the component location diagram, connect it from the pad marked for the left lead of C36 to the pad marked for the bottom lead of C41. (These caps are not used.) The jumper should be as short and direct as possible. The jumper has the electrical effect of making C35 a coupling capacitor between L4 and L7, in effect using C35 to also take over the function of C41, which is not used.
- Please mark schematic and component location diagrams with deleted parts and added jumper wire.
- The multiplier chain operates as follows on this band: the 12 MHz oscillator signal is tripled to 36 MHz in Q3 and doubled again to 72 MHz in Q4.
- Note that some dc test voltages may be a little different from those shown in the troubleshooting charts for 144 MHz sample used in original instruction manual.
- Be sure to preset all variable capacitors to mid-range before alignment to avoid false peaks.
- L4 and L7 are tuned alternately as a pair, using test point TP4. TP3 is not used.
- Because the fundamental frequency is only multiplied by 6 (instead of 12 for 144 MHz), the frequency deviation is only 1/2 of what it would be on high-band. Therefore, it may not be possible to obtain a full ±5 kHz deviation with modulation without a little distortion. This should not be objectionable though.