

HAMTRONICS® TD-5 SUBAUDIBLE TONE ENCODER/DECODER: ASSEMBLY, INSTALLATION, AND OPERATION

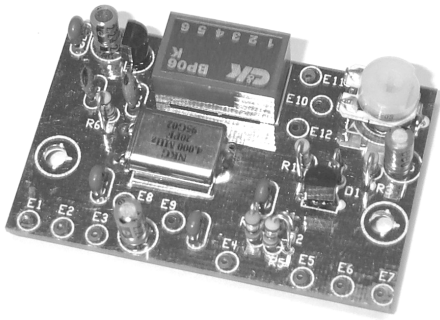

CAUTION. *The TD-5 contains static sensitive ic's, which require normal static prevention techniques when handling to avoid damage. Wearing a grounded wrist strap is a prudent practice. For wired units, do not remove the unit from its protective package until ready to install. For kits, do not open package with semiconductors until ready to install on board.*

FUNCTIONAL DESCRIPTION.

The TD-5 is a general purpose CTCSS Encoder and Decoder module designed with enhanced features to allow it to be used in repeater control. It is crystal controlled for precise tone accuracy and is easily tunable by setting a DIP switch to cover the entire range of subaudible tone frequencies from 67 to 254 Hz. Its CMOS circuitry operates on +7 to 15 Vdc, drawing only 7 mA!

As a general purpose tone encoder, you can easily adapt your existing fm transceiver to access all your favorite closed repeaters. If you only need one tone, you can select it with the DIP switch on the module. If you need several tones, the manual shows how you can set up a front panel switch to select between preset tones for several repeaters. A pot on the board allows you to set the transmitter deviation for the tone separately from your microphone audio.

As a general purpose receiver decoder, the same TD-5 can be used to mute receive audio unless the proper subaudible tone is present on the signal. A convenient control line can be used to manually unmute the receiver to allow monitoring the channel when desired, and a high pass filter gets rid of annoying tone buzz in the speaker audio. Unlike many such units, the TD-5 module handles both encode and decode! When used in a transceiver, your ptt line can be connected to the unit to switch between transmit and receive modes.

The TD-5 was designed especially to have the added features needed to provide closed access for your repeater. To block repeater transmission unless the user signal has the

proper subaudible tone, an output transistor grounds the COS line between the receiver and the control board to prevent it from recognizing that the squelch is open. The TD-5 provides remote on/off capability when used with a DTMF controller. Whenever you need to defeat the TD-5 and allow anyone to access the repeater, simply ground the control line with any touch tone controller and the repeater becomes an open repeater.

It can also be used as a repeater tone encoder. Most repeaters use CTCSS only on receive. But if you need to transmit a subaudible tone as well, it is a simple matter of connecting the tone output of a second TD-5 module to the modulator input of your exciter. There is a handy tone output level control to set the transmitter deviation.

CAUTION.

⚡ The TD-5 kit contains static sensitive ic's, which require normal static prevention techniques, such as wrist strap and grounded soldering iron to avoid damage. Do not remove the ic from its protective package until so instructed.

⚡ The kit also requires soldering a small surface mount ic to the pc board. If you don't feel you can do these operations properly, you may want to seek help from someone more experienced or exchange the unit for a wired/tested module.

THEORY OF OPERATION.

Refer to the schematic diagram.

The heart of the unit is the MX-465DW ic, which provides encoding and decoding of all standard subaudible tones. Pins 2 and 3 operate in a 4 MHz crystal oscillator circuit. Pins 5-10 are control lines which select the frequency, and pull up resistors are provided in the chip. Frequency selection normally is done with the DIP switch on board, but it can also be done with an external circuit placing grounds on selected lines using a front panel switch and a diode matrix arrangement. Pin 17 controls whether the ic is operating in the transmit or receive mode at any time.

Pin 24 is the input for the tone detector. If the audio present contains the proper subaudible tone, RX Detect line pin 15 goes hi. The output of this detector is integrated to prevent bouncing and falsing by C6. The turn on time constant is set with R4 and R5-D2 in conjunction with C6. The turn off time is set by R4 and C6. The integrated signal is applied to a comparator at pin 14, and the switched output is the RX Decode signal at pin 13.

The RX Decode output is used to turn Q1 on and off, and the transistor is used to inhibit the COS line going to a repeater controller,

such as our COR-5 module, thus providing closed access repeater operation. The Defeat line at E5 provides a way for a touch tone control circuit to defeat the COS Inhibit function when desired.

The RX Decode signal also switches the audio path between pins 23 and 19. Between these two pins is a switched capacitor high-pass filter, which attenuates audio frequencies below 250 Hz by about 36 dB while passing frequencies above 300 Hz. This can filter can be connected in series with the audio path in a receiver to remove the buzz associated with subaudible tones and also to mute the audio completely if the tone isn't present on the rf signal. The Push To Listen (PTL) line at pin 18 can be used to defeat the muting action when you want to monitor the channel to check for activity before transmitting.

When the RX/TX line at pin 17 is grounded, the ic changes to the transmit mode. In this mode, the switched capacitor high-pass filter can be used in the transmit audio path to remove frequencies below 250 Hz from the signal. This feature normally is not used in amateur radio applications, but in transceivers, it can be used to prevent low frequency speech components from falsing a CTCSS decoder at the receiver hearing the transmitted signal. When used, the audio line is run through pins 22 and 20 to the modulator in the transmitter.

ASSEMBLY.

GENERAL NOTES.

Construction is fairly simple. Refer to the parts list and component location diagram, and solder all parts in place, using short leads. Following are some special points to consider.

a. The ic is static sensitive. Suitable precautions must be taken when handling, including using a wrist strap and a grounded soldering iron.

b. Resistors and diodes mounted vertically are shown with the body of the resistor designated by a circle.

c. Observe polarity on electrolytic capacitors, diodes, transistor, and ic.

d. With modern CAD-produced pc boards, pad sizes are smaller than what you may be used to. Because the board has plated-through holes, it is the solder inside the hole, and not on the pad, which makes the electrical connection.

Use solder sparingly. It helps to use a small soldering tip and a minimal amount of small-diameter solder. It also helps to work under a magnifier lamp if you have one, especially for the ic.

e. Note that there is one hole in the

board next to the crystal which has no lead soldered to it. This is a "via", which carries ground through to pin 11 of the ic on the bottom of the board. There are also many holes which are used as terminals for connection to the outside world, many of which are optional and may not be used in your application. And you will note that holes connected to the ground plane are "thermals", a special pattern which allows connection but minimizes heatsinking to make soldering and unsoldering easier.

CONSTRUCTION SEQUENCE.

a. The ic is soldered to the bottom of the board with pin 1, identified by a dot in the plastic mold, toward R6 and the leads for the crystal. That would be the left end of the board as shown in figure 2. Make sure you have it oriented correctly before soldering.

Begin by tack soldering one corner and readjusting until all the leads line up properly with the tracks. Double check that you have pin 1 connected to the trace running to U2 and C3. Then, tack solder the opposite corner lead. Finally, solder all the other leads. If you accidentally get solder between two leads, drawing the iron between them away from the ic should separate the two pads. If necessary, use desoldering tool or wick to remove excess solder.

b. Turn the board over and orient as shown in the two top views.

c. Install crystal over ground plane as shown, and solder leads to pads under board. Lay crystal flat against ground plane, and tack solder the top of the can to the ground plane with a small bead of solder. This will be at the right hand side of the crystal can as shown in the top view, and it will hold the crystal securely in place.

d. Install the DIP switch with the switch numbering running in the proper direction. Solder all leads under board. If the switch supplied is a 7-position switch; in this case, cut off the leads for position 7 before mounting.

e. Install potentiometer R2 as shown and solder leads. *Be careful to elevate the pot leads slightly to prevent the bases of the leads from shorting to the ground plane.*

f. Solder voltage regulator U2 and transistor Q1, with proper orientation.

g. Install electrolytic capacitors, observing polarity.

h. Install the other (ceramic and monolithic) capacitors.

i. Install resistors and diodes, observing diode polarity. See detail of diodes next to top view.

j. Check over construction to be sure all parts are installed in the proper holes with the proper polarity. Check all solder joints for bad joints, solder splashes, etc.

INSTALLATION.

GENERAL.

Installation consists of mounting the module, selecting the tone frequency, providing power, and making connections to the required circuits in the radio equipment. The latter information is divided into two major sections: transceiver installation and repeater installation; choose whichever applies.

MOUNTING.

The TD-5 module is designed to be mounted to the side wall of a radio chassis with the pot and DIP switch at the top for easy access, just below the upper edge of the box. To locate the mounting holes, draw a line one inch below the top of the box. Then, mark the two mounting holes 1-7/8 inches apart on the line. Attach the module with 4-40 screws and standoffs or spacers as desired.

The usual location for the TD-5 module used with the receiver in a Hamtronics REP-200 Repeater is on the rear panel of the enclosure near the receive coax connector. This is convenient for connections to the feedthrough capacitors on the partition, and it allows easy access to the pot and switch for adjustment.

For transmit operation, the TD-5 usually is mounted in the exciter compartment, on the shield just to the right of the exciter. In many transceivers, you will probably be forced to find any practical space where the module will fit; you may even have to mount it in a mini-box attached to the rear of the radio.

SELECTING CTCSS FREQUENCY.

The tone frequency is selected by grounding binary control lines (see D0 thru D5 on schematic diagram). The ic has pullup resistors; so ground = lo logic level and open circuit = hi. Table 1 shows the pattern of logic signals required for each tone frequency.

DIP SWITCH METHOD.

If you only need one tone, you can select it with the DIP switch on the module. Set the six switch levers according to the logic levels indicated for the desired tone frequency in Table 1. Open on the switch is logic 1 (hi) and closed is logic 0 (lo).

FRONT PANEL SWITCH METHOD.

If you need several tones, for use in a transceiver to access several repeaters, you can set up a front panel switch to select between preset tones. To do so, you must remove the DIP switch or set all the levers to the open position. Then, connect diodes in a matrix to the lines you need to ground for each tone frequency.

Figure 1 shows such a matrix with three sample tone frequencies. The diodes are necessary to avoid shorting two lines together. Connect diodes to ground the lines designated for logic "0" in Table 1. Diode connections are

Table 1. DIP Switch Programming (Note: 1 = open, 0 = closed)						
Switch Pos →	1	2	3	4	5	6
67.0 Hz	1	1	1	1	1	1
69.3 Hz	1	0	0	1	1	1
71.9 Hz	1	1	1	1	1	0
74.4 Hz	0	1	1	1	1	1
77.0 Hz	1	1	1	1	0	0
79.7 Hz	1	0	1	1	1	1
82.5 Hz	0	1	1	1	1	0
85.4 Hz	0	0	1	1	1	1
88.5 Hz	0	1	1	1	0	0
91.5 Hz	1	1	0	1	1	1
94.8 Hz	1	0	1	1	1	0
97.4 Hz	0	1	0	1	1	1
100.0 Hz	1	0	1	1	0	0
103.5 Hz	0	0	1	1	1	0
107.2 Hz	0	0	1	1	0	0
110.9 Hz	1	1	0	1	1	0
114.8 Hz	1	1	0	1	0	0
118.8 Hz	0	1	0	1	1	0
123.0 Hz	0	1	0	1	0	0
127.3 Hz	1	0	0	1	1	0
131.8 Hz	1	0	0	1	0	0
136.5 Hz	0	0	0	1	1	0
141.3 Hz	0	0	0	1	0	0
146.2 Hz	1	1	1	0	1	0
151.4 Hz	1	1	1	0	0	0
156.7 Hz	0	1	1	0	1	0
159.8 Hz	1	0	0	0	1	1
162.2 Hz	0	1	1	0	0	0
167.9 Hz	1	0	1	0	1	0
173.8 Hz	1	0	1	0	0	0
179.9 Hz	0	0	1	0	1	0
183.5 Hz	0	1	0	0	1	1
186.2 Hz	0	0	1	0	0	0
189.9 Hz	1	1	0	0	1	1
192.8 Hz	1	1	0	0	1	0
196.6 Hz	0	0	1	0	1	1
199.5 Hz	1	0	1	0	1	1
203.5 Hz	1	1	0	0	0	0
206.5 Hz	0	1	1	0	1	1
210.7 Hz	0	1	0	0	1	0
218.1 Hz	0	1	0	0	0	0
225.7 Hz	1	0	0	0	1	0
229.1 Hz	1	1	1	0	1	1
233.6 Hz	1	0	0	0	0	0
241.8 Hz	0	0	0	0	1	0
250.3 Hz	0	0	0	0	0	0
254.1 Hz	0	0	0	1	1	1

made at the pads normally used for S1 connections to the ic data lines, i.e., the ic side of the switch, not the ground side. Lines designated for logic "1" should be left open, as there are pullup resistors in the ic.

HOW TO MAKE CONNECTIONS.

External connections to the module should be made with #22 hookup wire soldered to the terminal pads on the module. Normally, only pads E1-E7 along the bottom of the board are used; however, with certain options, E8-E12 may also be used. Cut hookup wires to length required for your installation, strip each end 1/4 inch, and then solder one end to terminal pad on the board.

POWER CONNECTIONS

B+ for the unit is connected to E2. The

negative supply normally is connected through the mounting hardware to the chassis, but E1 can be used for the ground connection if necessary. Since a 5V regulator is used in the TD-5, B+ can be anything from 7 to 15Vdc. Current drain normally is only about 6 mA.

TRANSCEIVER INSTALLATION.

TRANSMITTING A CTCSS TONE.

The TD-5 can be used to transmit a CTCSS tone to access closed repeaters or to operate in a system with tone squelch which separates users. The tone output level is adjustable up to 2V p-p (710 mV rms) into a high impedance circuit. The level will be somewhat lower with a load because of the resistor in series with the audio in the TD-5.

To add the CTCSS tone to your transceiver, connect a hookup wire from E7 on the TD-5 to the input of the modulator stage in the exciter. The exact circuit for the connection must be determined for the particular exciter you have.

It is important to inject the tone into the modulator of the transmitter in a way which bypasses the speech processing circuits for the microphone, but at the same time does not load down the audio coming from those circuits. Normally, there will be a low-pass filter which allows the audio to be injected into the modulator while keeping the oscillator rf signal from getting out into the audio circuits. This circuit normally is a series resistor and a shunt capacitor.

To put the TD-5 in the transmit mode, you must connect a jumper between E10 and E12. This grounds the TX/RX control line.

If you want to use the same unit for transmit and receive operation in a transceiver, you can connect E12 through a 1N4148 diode to the ptt line in the transceiver. This assumes your ptt line is grounded to transmit. The cathode should be connected to the ptt line and the anode to E12.

RECEIVER AUDIO MUTING.

To mute the audio in the receiver when no CTCSS tone is present, connect E3 and E4 in series with the audio path in the receiver somewhere between the discriminator and the deemphasis network, normally a series resistor and a shunt capacitor right after the discriminator output. This connection point should be ahead of the squelch muting circuit in the audio path. Consult the manual for your receiver to find appropriate connection point.

Input sensitivity is such that any tone level between 125-2000 mV p-p is acceptable (45-710 mV rms).

The muting circuit in the TD-5 also provides a high pass filter to eliminate any buzz from the received CTCSS tones.

If you want to be able to monitor some-

times when the proper CTCSS tone is absent, you can use a switch to control the ground path to the PTL control line at E11. To use this feature, you must break the pc trace on the rear of the board between E10 and ground.

REPEATER INSTALLATION.

AUDIO INPUT.

Audio from the receiver normally should be picked up from the discriminator for connection to E3. Later model Hamtronics® receivers have a terminal on the receiver for the discriminator audio. On earlier models or on other brands of receivers which do not have a dedicated terminal, the discriminator audio is accessible at the resistor/capacitor junction of the deemphasis network. Consult the manual for your receiver to find appropriate connection point. Input sensitivity is such that any tone level between 125-2000 mV p-p is acceptable (45-710 mV rms).

REPEATER INHIBIT CONNECTIONS.

An output transistor in the TD-5 provides a ground at E6 when no tone is present and an open circuit when the proper tone is received. In a repeater, this switched output normally is used to inhibit the repeater by grounding the COS signal from the receiver to the COR board in the repeater. The easiest place to connect is at the feedthrough capacitor used to carry the COS signal through the receiver partition.

If you wish to use touch-tone control to disable the TD-5 and allow open access repeater operation, you will need to add another feedthrough capacitor to the receiver partition and a wire from the other side of the ft cap to the auxiliary control output of a touch-tone controller. In the receiver compartment, connect the control line from the feedthrough capacitor to Defeat terminal E5 on the TD-5.

OPTION TO TRANSMIT ENCODED TONE.

In most repeaters, it is unnecessary to retransmit the subaudible tone; it is only necessary to inhibit the repeater if a station is heard without the proper tone.

If you wish to have your repeater transmit a CTCSS tone, do the following.

- Add a TD-5 module near the exciter. In the REP-200 Repeater, the TD-5 usually is mounted in the exciter compartment, on the shield just to the right of the exciter. Note that the TD-5 cannot do transmit and receive modes at the same time; so a separate TD-5 must be used for transmit operation.

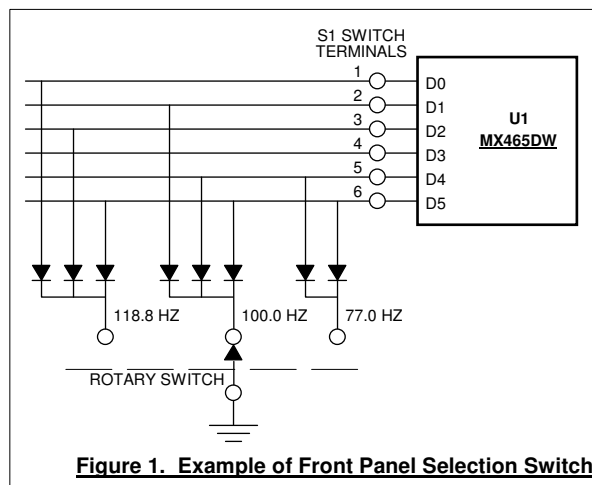

Figure 1. Example of Front Panel Selection Switch

b. Connect a hookup wire from E7 on the TD-5 to the input of the modulator stage in the exciter. The exact circuit to connect to must be determined for the particular exciter you have.

For our TA51 (vhf) Exciter, connect to the loop at the top of R22. This injects the audio directly into the low pass filter at the input of the modulator.

For our TA451 (uhf) Exciter, connect a 47K resistor from E7 on the TD-5 over to the lead of C11 closest to deviation pot R15. This also injects the tone into the modulator, but the 47K resistor prevents loading of the circuit in the uhf exciter.

For our synthesized exciters, connect to the dedicated ctcss input terminal provided on the exciter.

If you need to connect the tone to another type of transmitter, use a similar approach. It is important to inject the tone into the modulator of the transmitter in a way which bypasses the speech processing circuits for the microphone, but at the same time does not load down the audio coming from those circuits. Normally, there will be a low-pass filter which allows the audio to be injected into the modulator while keeping the oscillator rf signal from getting out into the audio circuits.

c. You must also connect B+ to E2 on the TD-5 as explained earlier.

d. To set the TD-5 for transmit mode, connect a jumper between E10 and E12. If you want to be able to turn the transmitted CTCSS tone off, you can connect a switch to disconnect the ground when you do not want the tone.

TRANSMIT LEVEL ADJUSTMENT.

TONE LEVEL control R2 on the TD-5 is adjusted for the desired deviation of the subaudible tone. The TD-5 has a resistor (R3) in series with its output to avoid loading down the exciter audio circuits. The tone output level is adjustable up to 2V p-p (710 mV rms) into a high impedance circuit. The level will be somewhat lower with a load.

If TONE LEVEL control R2 provides too high a level, even with it adjusted to a low setting, additional resistance can be added in series with output terminal E7 or R3 can be made larger.

Normally, the level of the tone should be set for about 300 Hz deviation. That is sufficient for any normal decoder to detect. (Good decoders normally decode anything over 50-100 Hz deviation.) Sometimes people want to use much higher levels on tones, and not only is this unnecessary but it causes the tone to be heard as a buzz on the voice signal; if set high enough, may even have a detrimental effect on a touch-tone command system.

TROUBLESHOOTING.

GENERAL.

The circuit is relatively simple. First, re-read the theory of operation on page 1. Because all major functions of the unit are performed in ic U1, troubleshooting is pretty straight forward. An oscilloscope usually is essential in troubleshooting, although it may be possible to get by with just a voltmeter.

CURRENT CONSUMPTION.

The TD-5 can operate on any source of +7 to 15Vdc, and it normally draws about 6 mA.

AUDIO LEVELS.

The transmit tone output level is adjustable up to 2V p-p (710 mV rms) into a high impedance circuit. The level will be somewhat lower with a load because of the resistor in series with the audio in the TD-5.

Receive input sensitivity is such that any tone level between 125-2000 mV p-p is acceptable (45-710 mV rms). Output of the receive filter and switch circuit at E4 should be about the same as the input level.

VOLTAGE TESTS.

Table 2 gives dc and oscillator voltages for the main ic (U1) measured on a sample unit. These readings are typical but may vary somewhat. As always, such data should be used in conjunction with a logical troubleshooting procedure to avoid jumping to conclusions if a voltage is a little different in your unit. Some are dependent on being in either transmit or receive mode. Note that pins used as logic inputs are not shown.

TALK-OFF PROBLEMS.

The response time and deresponse time of the decoder circuit is set by R4, R5, and C6. The purpose of this integrator is to prevent bouncing on and off any time a short duration of low frequency audio is detected. In commercial operation, the circuit would normally be set up to respond in 250 mSec. However, this short response time requires that the transceivers have special audio filters which prevent any voice audio from ever being transmitted in the subaudible tone range.

Because amateur radio transceivers rarely have such filters, many are capable of transmitting voice signals with audio components easily getting down into the 100 Hz range of the usual CTCSS tone frequencies used in repeaters. This can cause two problems: talk-off, which is voice audio appearing out of phase with the CTCSS tone and effectively canceling it, and talk-on, which is voice audio components appearing at the designated tone frequency, e.g., 100 Hz. In the case of the latter, a man's voice could occasionally trigger the CTCSS decoder in a repeater, each time causing the repeater to key up for 3-5 seconds until the tail drops.

Talk-on and talk-off can also be caused by incorrect adjustment of the modulation or the carrier frequency in the transceiver. If the audio consistently bangs up against the limiter because the mic gain is too high, the squared off audio can cause low frequency components which trigger the CTCSS decoder. The answer to this problem is for the user to properly adjust the mic gain and limiter in his radio. Likewise, off frequency operation of the transceiver causes distortion by having modulation sidebands extend over the sharp edge of the i-f filter in the receiver.

To minimize these problems for amateur radio service, we have chosen values for the integrator circuit which provide a slightly longer response time, about 500 mSec, making it much less likely a voice component could be long enough to cause a response. Of course, this may cause a noticeable delay in pickup time when someone keys the repeater.

If you prefer to shorten the response time, you can lower the value either of C6 or of R4 and R5, perhaps cutting them in half. You can try the new values for awhile and see if the change is acceptable.

REPAIR.

The only special repair procedure is replacement of a damaged ic. Because it is a surface mount device, conventional desoldering techniques may not remove enough solder to allow removal. If you know for sure that the ic is dead, it is simpler and it protects the pc board from damage if you use a fine pair of cutters to cut each lead of the ic at the edge of the package. Then, unsolder and remove one lead at a time. After that, it is relatively easy to use a vacuum desoldering tool or Solder Wick to remove any excess solder prior to installing a new ic. Refer to the assembly instructions for information on orientation of the ic.

Table 2. U1 Test Voltages

Pin#	Function	Test Voltage
1	V _{DD}	+5V
2	Oscillator	7V p-p @ 4 MHz
3	Oscillator	5V p-p @ 4 MHz
4	Load/Latch	+5V
11	V _{SS}	0V
12	Comparator Ref	+3.2V
13	RX Decode **	+5V no tone, 0V tone
14	Comparator In **	+4.2V tone, 0 no tone
15	RX Detect **	+5V tone, 0V no tone
16	Tone Out ‡	2.2V p-p tone
19	RX Out	+2.5V
20	TX Out	+2.5V
21	Bias Bypass	+2.5V
22	TX In	+2.3V
23,24	RX AF In	+2.5V
** Receive Mode Only		
‡ Transmit Mode Only		

PARTS LIST.

Note: Factory built units use surface mount caps and resistors on the rear of the board.

Ref #	Value	(marking)
C1-C2	0.1 µf 805 smt	
C3	2.2 uf electrolytic	
C4	0.1 µf 805 smt	
C5	2.2 uf electrolytic	
C6	0.1 µf 805 smt	
C7	2.2 uf electrolytic	
C8-C9	33 pf NP0 850 smt	
D1-D2	1N4148 diode	
Q1	2N3904 NPN xstr	
R1	4.7K 805 smt resistor	
R2	20K trim pot.	
R3	10K 805 smt resistor	
R4	3.9 meg 805 smt resistor	
R5-R6	2 meg 805 smt resistor	
S1	7 pos. DIP switch	
U1	MX465DW ic	
U2	78L05 5V regulator ic	
Y1	4.000 MHz crystal	

