

TEMPO S30 OPERATING AND MAINTENANCE INSTRUCTIONS

INTRODUCTION

The Tempo S30 is a nominal 30 watt output, 1.5 watt drive RF amplifier designed to mate with the Tempo S1 hand held, or any 1 to 5 watt drive portable transceiver. It operates in the 144 to 148 MHz 2 meter amateur band. The S30 comes with a drive cable which mates with the S1, and a 3 foot fused DC cable. The small size of the amplifier makes it easy to install, yet it has enough heat sink to operated reliably and cool.

UNPACKING AND INSTALLATION

The S30 was tested at the factory at 144 to 148 MHz. Further alignment may be necessary to match the antenna in your installation. Please read the alignment procedure carefully to prevent damage to the amplifier. If the amplifier is operating at its nominal output, no alignment is necessary. The solid state devices in the amplifier are easily damaged if they are serviced incorrectly. The equipment warranty can not cover damage caused by negligent service. We recommend that all service be accomplished by a knowledgeable technician.

Remove the amplifier from its shipping box and packing and examine it for visible damage. If the amplifier was damaged in shipping, save the box and packing and notify the transportation company immediately. Do NOT put the amplifier into service if it has been damaged.

The following accessories should be included with the S30. A 6 foot drive cable terminated on one end with a UHF connector, and on the other end with a mini phono plug. Also included are a 3 foot fused DC plug, a warranty card, and an instruction sheet. When installing the S30, keep in mind that the equipment should be mounted as closely as possible to the 13.8 VDC power source to prevent low output caused by a voltage drop in the DC cable. We recommend installation inside the vehicle for mobile installations. The red power lead connects to the battery's positive (+) terminal and the black DC lead connects to the battery's negative (-) terminal. The diagram below shows the necessary connections.

The DC power cables should be connected directly across the battery to prevent damage to the ignition system of the vehicle caused by the high operating current of the amplifier. Mount the amplifier at the desired location and plug the DC cable into the 2 pin Jones plug on the amplifier.

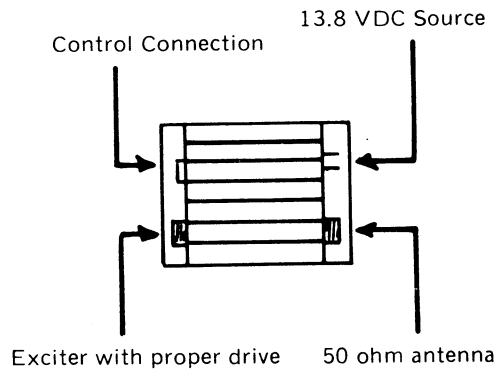

FOR MAXIMUM OUTPUT POWER

MAXIMIZE YOUR OPERATING PARAMETERS

Connect the RF OUTPUT coax connector to an appropriate 50 ohm antenna using RG-8, RG-58, or RG-8X coax. The S30 will operate with maximum output when operating into a 50 ohm load with a low SWR. The SWR of the antenna should be adjusted for a minimum at the desired operating frequency. Also remember that long coax leads cause significant power loss at VHF frequencies. Connect the supplied drive cable to the transceiver and to the RF INPUT connector on the amplifier. The mobile installation has been completed when all of these connections have been made.

For base station installations, the amplifier must be connected to a 13.8 VDC source (either a storage battery or an AC to DC power converter) capable of supplying at least 8 amps.

The amplifiers are designed to key into transmit automatically when driven with more than 1 watt of RF. The CONTROL Jack, described later disables the automatic keying circuit to turn the amplifier off. The amplifier draws such minimal current in the standby mode that there is no need to turn it off under normal circumstances.

CONTROL CONNECTION

The CONTROL jack on the amplifier allows remote on/off control of the amplifier. As shown in the diagram below, grounding the control line (the ring of the control plug) disables the amplifier and connects the transceiver directly to the antenna. There is no significant current through the jack, so nearly any kind of switch can be used. The S30 is not supplied with a control plug or switch. The required plug is a Switchcraft S-260 plug.

SPECIFICATIONS

Power Output 20 to 40 watts
Drive Requirements . . . 1 to 5 watts
Bandwidth 4 MHz
Power Requirements . . . 13.8 VDC
 8 amps maximum during transmit
 5 ma maximum during receive
Antenna Changeover . . Automatic
 built-in RF sensing
Duty Cycle 50% intermittent
 amateur mobile service
Dimensions . . . 4½ x 4 x 3¼ inches
Weight 3 pounds approx.

Gain Approximately 12 db
Frequency Range .144 to 148 MHz
Harmonic Attenuation . . 60 db or
 better below carrier.
Input/Output Impedance .50 ohms
Type of Emission . . . FM (Class C)
Connectors. RF IN and OUT - UHF
 CONTROL - 3/16" stereo phono
 13.8 VDC - 2 pin Jones plug
Mismatch Protection . . . Balanced
 emitter transistors withstand
 infinite VSWR.

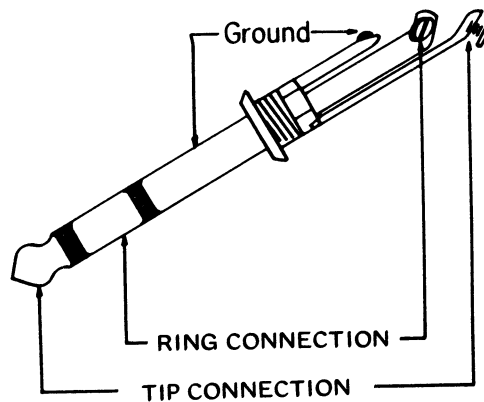

ALIGNMENT

WARNING: The transistors in this amplifier are easily damaged if they are shorted. An insulated alignment tool is recommended for all service. The equipment warranty can not extend to damage caused by careless service.

See the schematic and parts list on the next page. Also note the test set up described in the diagram below. Make certain that the driver power is less than 5 watts. Transmit only into a proper 50 ohm dummy load. Drive the amplifier at the desired frequency and make the following adjustments.

Carefully adjust C3 for maximum power output. Adjust C4 for maximum output (if C4 is too far out of adjustment the relay will not key). Adjust C10 for maximum output. Adjust C9 for maximum output. Adjust C7 for maximum output.

Readjust C3 for maximum output. Readjust C10 for maximum output. Finally readjust C4 for maximum output.

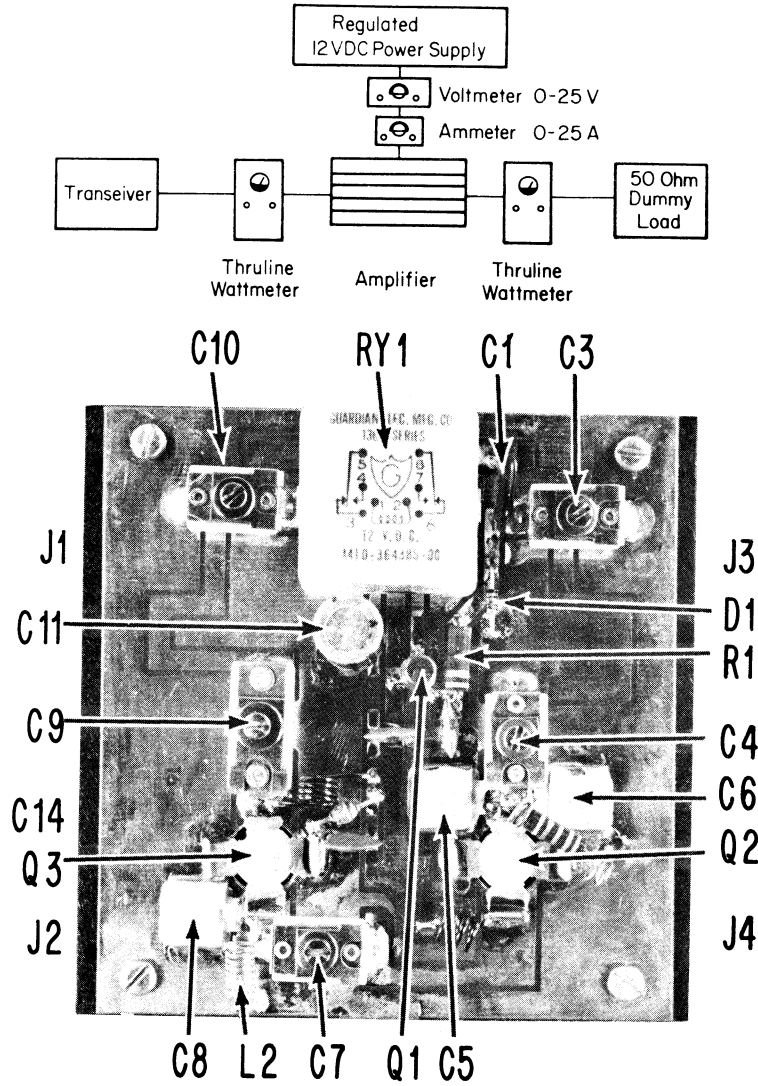

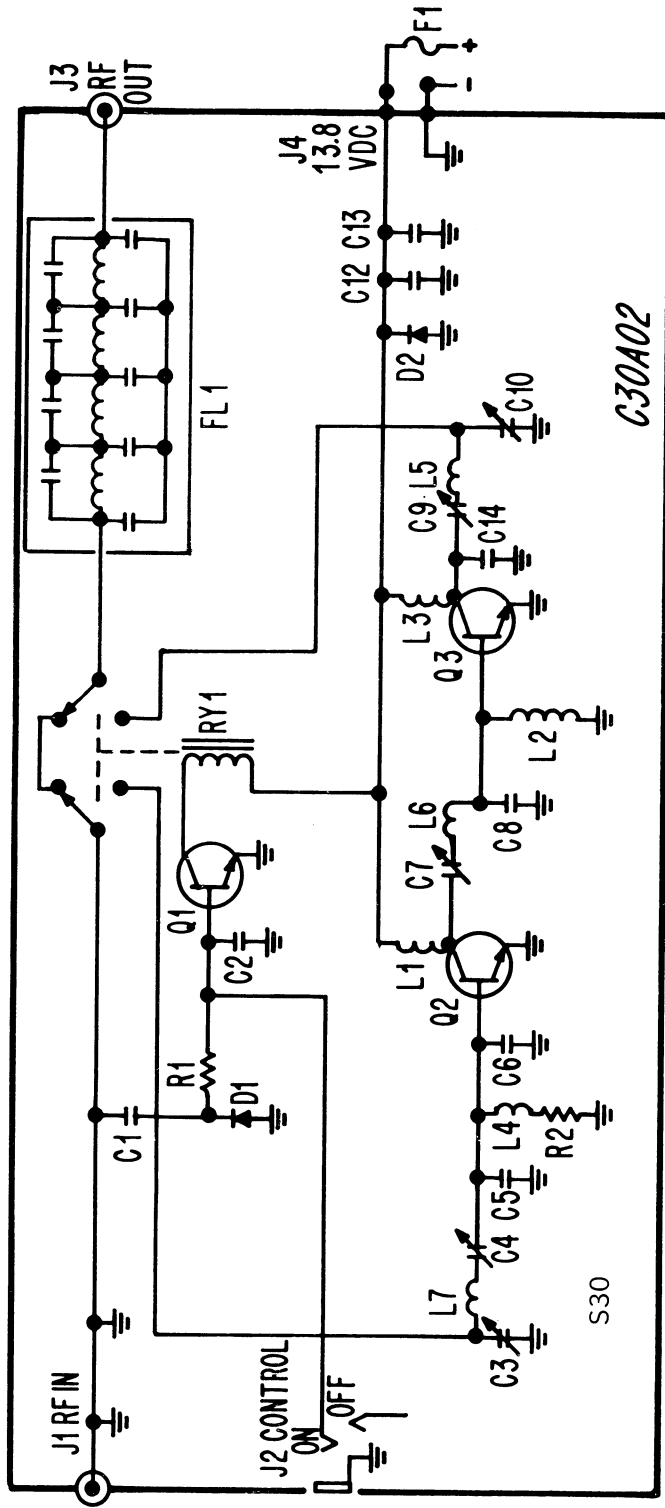

- C1 Mica dipped, 2 pf
- C2 Ceramic disc, .01 mf
- C3 and C4 Arco 404 trimmer
- C5 and C6 Mica chip, 200 pf
- C7 Arco 425 trimmer
- C8 Mica chip, 200 pf
- C9 Arco 406 trimmer
- C10 Arco 404 trimmer
- C12 and C13 Ceramic disc, .01 mf
- C14 Mica chip, 200 pf
- RY1 Guardian 1365, 12 VDC

- D1 1N4148
- D2 HEP-R0091 or equiv.
- F1 3 AG, 8 amp
- FL1 Henry VHF Filter
- J1 UHF type, RF INPUT
- J2 3/16" Phone plug, CONTROL
- J3 UHF type, RF OUTPUT
- J4 2-pin Jones plug, 13.8 VDC

- L1 4 turns, 1/4 inch diameter
- L2 8 turns, .125 inch diameter
- L3 4 turns, 1/2 inch diameter
- L4 2 turns, part of R2
- L5, L6, L7 strip line inductors
- Q1 2N2222A
- Q2 CTC B12-12
- Q3 CTC B40-12
- R1 2.2 K ohms, 1/4 watt
- R2 3 ohms, 1/4 watt

HENRY RADIO 11240 W. Olympic Blvd. Los Angeles, CA 90064